

GMC

MOTORHOME and TRANSMODE PARTS BOOK

MODELS

ZEO 6081, 6581, 6582

ZEO 6083, 6583, 6584

1973 - 1978

This parts book replaces the previous MotorHome Parts Book 78Z printed in November, 1977

All illustrations and specifications contained in this catalog are based on the latest production information available at the time of publication approval. General Motors Corporation reserves the right to make changes at any time without notice in colors, materials, equipment, specifications and models, and also to discontinue models.

GENERAL MOTORS PARTS DIVISION
TRUCK PARTS PUBLICATIONS DEPT.
BELLEVILLE, MICH. 48111

78Z

GROUP INDEX

Front Axle	1
Brakes	4
Cooling	6
Electrical	7
Engine	8
Frame	11
Fuel	12
Air Suspension	14
Steering	16
Transmission	17
Wheels-Hubs	19
Tools	22
Body	23
Heater and Air Conditioning	26
Furnishings	28
Numerical Index	
Alphabetical Index	

FURNISHINGS

LIST OF SUB GROUPS

Name	Group No.
AIR CONDITIONER—ROOF MOUNTED, DUO—THERM	28.004
AIR CONDITIONER—ROOF MOUNTED, MARK IV	28.002
ATTACHMENTS—VACUUM SWEEPER	28.073
BED—GAUCHO/DOUBLE	28.160
BED—PERMANENT	28.156
BED—TWIN	28.158
BLOWER—SUBURBAN FURNACE	28.029B
BUNK—TWIN REAR UPPER	28.134
CABINET—SUBURBAN FURNACE	28.029A
CABINETS—OVERHEAD	28.120
CABINETS—OVERHEAD (W/FISHING EQUIPMENT RACK & GUN RACK)	28.120
CARBURETOR—ONAN 4KW GENERATOR	28.044A
CARPETING	28.106
CARTRIDGE—WATER PURIFIER	28.052A
CEILING PANELS AND MOULDING (W/ZE06582, ZE06584)	28.174E
CEILING PANELS AND MOULDING (Exc. ZE06582, XE06584)	28.174
CHASSIS—ONAN 4KW GENERATOR	28.044D
CHASSIS—ONAN 6KW GENERATOR	28.045A
CLOSET—BROOM/VACUUM SWEEPER	28.164
CLOSURE—HEATER	28.154
COMPARTMENT ASSY.—BEVERAGE DISPENSER	28.128
CONTROL—ONAN 4KW GENERATOR	28.044C
CONTROL—ONAN 6KW GENERATOR	28.045H
CONTROLS—GAS/ELECTRIC REFRIGERATOR (INSTA—MATIC)	28.057A
DAVO/BUNK FRONT	28.132
DINETTE/DOUBLE BED	28.136
DINETTE/SINGLE BED—AUXILIARY	28.140
DISPOSAL—WASTE	28.078
DRAPES, SLIDES, STOPS, TRACKS	28.110
DRESSER—REAR	28.162
DUCT WORK—DUO—THERM 30,000 BTU FURNACE (W/ZE0581)	28.023C
DUCT WORK—SOL—AIRE 30,000 BTU FURNACE (W/ZE06582, ZE06584)	28.023F
DUCT WORK—SOL—AIRE 30,000 BTU FURNACE (Exc. ZE06582, ZE06584)	28.023
ENGINE—KOHLER 4KW GENERATOR	28.046A
FAUCET—BATH SINK (FIRST DESIGN)	28.062
FAUCET—BATH SINK (SECOND DESIGN)	28.062H
FAUCET—GALLEY	28.064
FAUCET—WATER TREATMENT UNIT	28.052
FILLER—WATER (FRESH WATER TANK)	28.051C
FUEL SYSTEM—ONAN 6KW GENERATOR	28.045C
FURNACE—30,000 BTU, SUBURBAN (FIRST DESIGN)	28.028
FURNACE—CHAMBER AND BURNER ASSEMBLY (SUBURBAN) (SECOND DESIGN)	28.028A
FURNACE—22,000 BTU, SUBURBAN	28.029
FURNACE—30,000 BTU, DUO—THERM	28.20F
FURNACE—30,000 BTU, SOL—AIRE	28.020
GALLEY SINK AND FAUCET (PRIOR TO 1975)	28.063
GALLEY SINK AND FAUCET (EFF. W/1975)	28.064
GAUGE—HOLDING TANK (PANEL)	28.038
GEAR COVER AND GOVERNOR—ONAN 6KW GENERATOR	28.045D
GEAR COVER—ONAN 4KW GENERATOR	28.044G
GENERATOR—KOHLER 4KW	28.046
GENERATOR—ONAN 4KW	28.044
GENERATOR—ONAN 6KW (INCLUDES: MUFFLER KIT)	28.045
HEATER—WATER (FIRST DESIGN)	28.034
HEATER—WATER (SECOND DESIGN)	28.034J
IGNITION—ONAN 4KW GENERATOR	28.44H
IGNITION—ONAN 6KW GENERATOR	28.045E

FURNISHINGS

LIST OF SUB GROUPS

Name	Group No.
KOHLER 4KW GENERATOR MOUNTING	28.046C
LAMP—BATH	28.049
LAMP—FLOOR (AISLE)	28.049A
LAMP—HALL & LIVING AREA	28.048
LAMP—READING	28.047
LINES—MOTOR GENERATOR FUEL	28.042
LOCKER—BEDDING	28.155
MODULE—BATHROOM	28.172
MODULE—CLOSET	28.124
MODULE—GALLEY	28.128
MODULE—REFRIGERATOR	28.168
MOTOR—STARTING, ONAN 6KW GENERATOR	28.045G
ONAN 4KW GENERATOR—CYLINDER BLOCK CRANKSHAFT, FLYWHEEL,	28.044B
ONAN 4KW GENERATOR—FUEL SYSTEM	28.044F
ONAN 4KW GENERATOR—OIL SYSTEM	28.044J
ONAN 6KW GENERATOR—CYLINDER BLOCK, CRANKSHAFT, FLYWHEEL,	28.045B
ONAN 6KW GENERATOR—OIL SYSTEM	28.045F
PANEL—CONTROL, KOHLER 4KW GENERATOR	28.046B
PANEL—MONITOR	28.040
PANEL—SWITCH (LIGHT)	28.049B
PANELS—SIDE AND MOULDING	28.176
PLUMBING—BATHROOM MODULE	28.172D
PLUMBING—GALLEY MODULE	28.130
PUMP—FRESH WATER (FIRST DESIGN)	28.050
PUMP—FRESH WATER (SECOND DESIGN)	28.050F
PUMP—FUEL, ONAN GENERATOR	28.044E
PURIFIER—WATER	28.052C
RANGE—3 BURNER WITH OVEN (COLEMAN)	28.054
RANGE—3 BURNER WITH OVEN (MAGIC CHEF)	28.054A
RANGE—4 BURNER WITH OVEN (COLEMAN)	28.055
REFRIGERATOR—ALL ELECTRIC (6 & 7.5 CU. FT.) (NORCOLD)	28.056
REFRIGERATOR—GAS/ELECTRIC (6 & 7 CU. FT.) (INSTA—MATIC)	28.057
SEAT—LOVE	28.142
SENDING—UNIT—HOLDING TANK	28.039
SHOWER HEAD	28.060
SIDE FACING SETTEE/DOUBLE BED AND REAR DINING TABLE	28.152
STARTING MOTOR—ONAN 4KW GENERATOR	28.044K
SWEEPER—VACUUM	28.072
SWIVEL LOUNGE SEATS AND AIR CRAFT TABLE	28.144
TABLE—DRIVER'S COMPARTMENT	28.148
TANK—FRESH WATER (INCL. FITTINGS) (FIRST DESIGN)	28.051
TANK—FRESH WATER (INCL. FITTINGS) (SECOND DESIGN)	28.051A
TANK—L.P.G. (INCLUDES VALVES)	28.030
TOILET PAPER AND CHEMICALS	28.067
TOILET—AQUA—MAGIC	28.068
TOILET—ELECTRA—MAGIC	28.070
VENT—BATH POWER	28.075A
VENT—BATH, NON POWER	28.075
VENT—KITCHEN RANGE	28.075B
VENT—NON—POWER ROOF	28.074
VENT—POWER ROOF (EFF. w/1975)	28.074B
VENT—POWER ROOF (PRIOR TO 1975)	28.074A
VENTS—PLUMBING & REFRIGERATION	28.077
WATER FILL COMPARTMENT (FRESH WATER TANK)	28.051B
WATER TREATMENT UNIT AND FAUCET	28.052B
WOOD AND CUSHION COVERING	28.180

FURNISHINGS

NOTES

FURNISHINGS

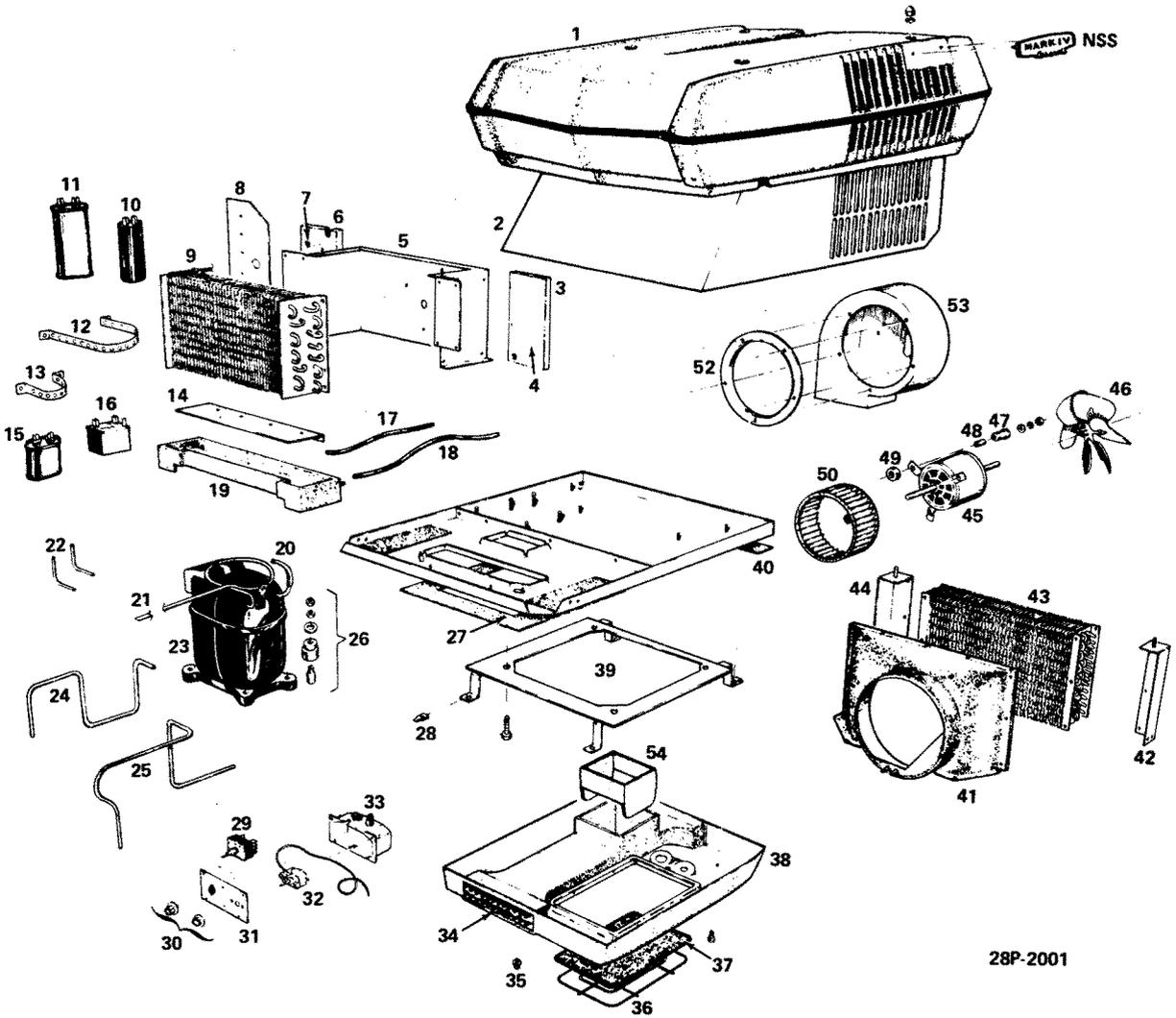

28.002 AIR CONDITIONER - ROOF MOUNTED, MARK IV

FURNISHINGS

KEY 230 260 PART NUMBER

28.002 AIR CONDITIONER—ROOF MOUNTED, MARK IV

—	1	1	708712	AIR CONDITIONER—roof mounted
1	1	1	707768	COVER—roof mounted air conditioner
2	1	1	707774	ENCLOSURE
3	1	1	707794	EXTENSION—bulkhead (LH)
4	1	1	707796	INSULATION—bulkhead extension (LH)
5	1	1	707772	PLENUM—leaving
6	1	1	707795	EXTENSION—bulkhead (RH)
7	1	1	707797	INSULATION—bulkhead extension (RH)
8	1	1	708710	SHIELD—heat
9	1	1	707762	COIL—evaporator
10	1	1	707757	CAPACITOR—start, compressor (380 volts)
11	1	1	707758	CAPACITOR—run, compressor
12	1	1	707787	STRAP—capacitor, compressor
13	1	1	707788	STRAP—capacitor, motor
14	1	1	707775	BAFFLE—water
15	1	1	707759	CAPACITOR—run, motor
16	1	1	707763	RELAY—potential, compressor
17	1	1	—	HOSE—drain (3/8" x 17-1/2") (procure locally)
18	1	1	—	HOSE—drain (3/8" x 20") (procure locally)
19	1	1	707773	PAN—drain (incl. tubes)
20	1	1	707776	TUBE—process
21	1	1	707777	TUBE—suction
22	1	1	707778	TUBE—feeder
23	1	1	707756	COMPRESSOR
24	1	1	707779	TUBE—discharge
25	1	1	707780	TUBE—capillary
26	1	1	707769	PAD—mounting, compressor
27	1	1	708704	PAD—mounting (18" x 18" x 2" x 3/4") (between base and roof)
28	1	1	708711	CLIP—mounting plate
29	1	1	707764	SWITCH—rotary
30	1	1	707793	KNOB—control
31	1	1	707792	COVER—control box
32	1	1	707765	THERMOSTAT
33	1	1	707791	BOX—control
34	1	1	708703	LOUVER—air duct
35	1	1	708702	KNOB—air divider
36	1	1	707800	GRILLE—return, air
37	1	1	708701	FILTER—return air (incl. frame)
38	1	1	707771	PLENUM—discharge (incl. air duct)
39	1	1	707770	PALTE—mounting
40	1	1	708709	PAD—mounting (20" x 2" x 3/4") (between base and roof)
41	1	1	707786	SHROUD—fan
42	1	1	707789	BRACKET—condenser mounting (LH)
43	1	1	707761	COIL—condenser
44	1	1	707790	BRACKET—condenser mounting (RH)
45	1	1	707760	MOTOR—blower
46	1	1	707785	BLADE—fan
47	1	1	707782	TUBE—grommet, motor mounting
48	1	1	707784	SLEEVE—motor mount
49	1	1	707783	WASHER—grommet, motor mounting
50	1	1	707781	WHEEL—blower
51	1	1	707767	BASE
52	1	1	707799	RING—inlet
53	1	1	707798	SCROLL—blower
54	1	1	NPN	DUCT—plenum
—	1	1	707766	HARNES—wiring (not illustrated)

FURNISHINGS

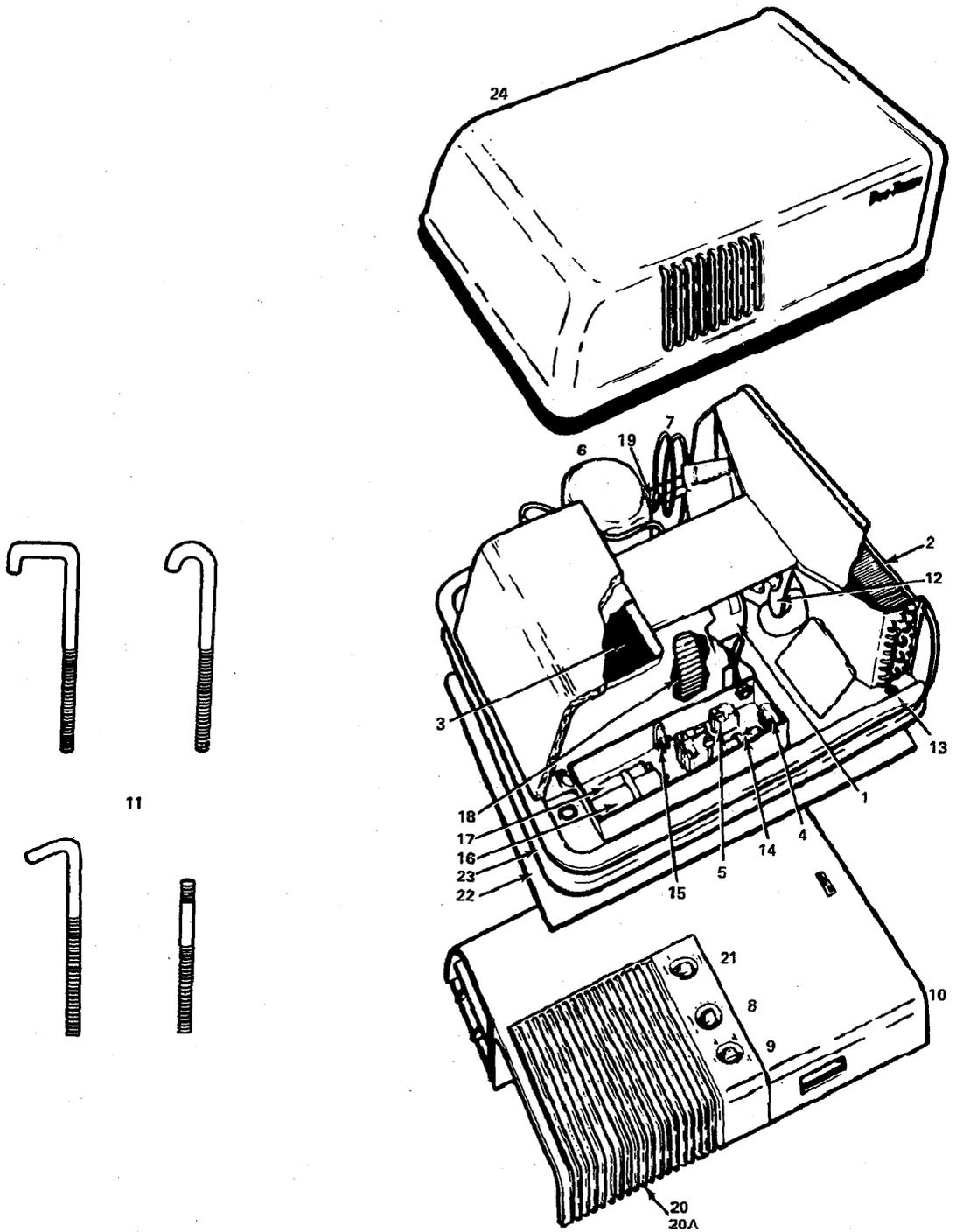

28P-3006

28.004 AIR CONDITIONER - ROOF MOUNTED, DUO-THERM

FURNISHINGS

KEY 230 260 PART NUMBER

28.004 AIR CONDITIONER—ROOF MOUNTED, DUO—THERM

—	1	1	793957	KIT—a/c compressor (including items marked with asterisk)
—	—	1	2033919	AIR CONDITIONER ASSY.—duo—therm roof mounted (rear) (also use 1-721026 air box) (11,000 BTU) (1978)
—	—	1	796251	AIR CONDITIONER ASSY.—duo—therm roof mounted (rear) (complete) (11,000 BTU) (ref. only) (prior to 1978)
—	—	1	2004563	AIR CONDITIONER ASSY.—duo—therm roof mounted (rear) (also use 1-721026 air box assembly) (11,000 BTU) (repl. 796251) (for opt. see 2014090) (prior to 1978) (ref. only)
—	—	1	2014090	AIR CONDITIONER ASSY.—duo—therm roof mounted (rear) (does not include air box assembly) (11,000 BTU) (Opt. for 2004563) (prior to 1978)
—	—	1	2033916	AIR CONDITIONER ASSY.—duo—therm roof mounted, (front) (also use 1-721026 air box) (13,500 BTU) (1978) (repl. 2004563)
—	—	1	2004562	AIR CONDITIONER ASSY.—duo—therm roof mounted, (front) (also use 1-721026 air box assembly) (13,500 BTU) (prior to 1978) (repl. 720102)
—	1	1	720102	AIR CONDITIONER ASSY.—duo—therm roof mounted (front) (13,500 BTU) (complete) (ref. only) (prior to 1978)
1	1	1	720192	MOTOR ASSY.—air conditioner (SOA) (w/720102, 2004562)
1	1	1	2009926	MOTOR ASSY.—fan (SOA) (w/796251, 2004563, 2014090)
2	1	1	2009927	COIL ASSY.—condenser (SOA) (w/796251, 2004563, 2014090)
2	1	1	720193	COIL ASSY.—condenser (SOA) (w/720102, 2004562)
3	1	1	720194	COIL ASSY.—evaporator (SOA) (w/720102, 2004562)
3	1	1	2009928	COIL ASSY.—evaporator (SOA) (w/796251, 2004563, 2014090)
4	1	1	720195	RELAY ASSY.—time delay (SOA) (w/720102, 796251, 2004562, 2004563, 2014090)
5	1	1	720196	RELAY ASSY.—start (SOA) (w/720102, 796251, 2004562, 2004563)
6	1	1	* NS	COMPRESSOR ASSY.—air conditioner (use 793957 kit) (w/720102, 2004562)
6	1	1	2013249	COMPRESSOR KIT—air conditioning (incl. compressor, dryer & filter) (w/796251, 2004563) (repl. 2009929)
6	1	1	2013252	COMPRESSOR KIT—air conditioning (incl. compressor, dryer & filter) (w/2014090)
7	1	1	2009931	DRIER ASSY.—air conditioning (SOA) (w/796251, 2004563, 2014090)
7	1	1	* 720198	DRIER ASSY.—air conditioner (SOA) (w/720102, 2004562)
8	1	1	720199	THERMOSTAT ASSY.—air conditioner (SOA) (for knob use No. 721038) (w/720102, 796251, 2004562, 2004563, 2014090)
9	1	1	720200	SWITCH ASSY.—blower (SOA) (for knob use No. 721038) (w/720102, 796251, 2004562, 2004563, 2014090)
10	1	1	721026	AIR BOX ASSY.—air conditioner (SOA) (w/720102, 796251, 2004562, 2004563, 2014090)
11	1	1	721027	BOLT KIT—anchor (SOA) (w/720102, 796251, 2014090)
12	1	1	721028	BLADE—fan (w/720102, 2004562)
12	1	1	2009932	BLADE—fan (w/796251, 2004563, 2014090)
13	1	1	2009933	PAN—base (w/796251, 2004563, 2014090)
13	1	1	721029	PAN—air conditioner base (w/720102, 2004562)
14	1	1	721030	CAPACITOR—start (w/720102, 2004562)
14	1	1	2009934	CAPACITOR—start (w/796251, 2004563)
15	1	1	2009935	BLOCK—terminal (w/796251, 2004563)
15	1	1	721031	BLOCK ASSY.—a/c start capacitor terminal (w/720102, 2004562, 2014090)
16	1	1	721032	CAPACITOR—run (w/720102, 2004562)
16	1	1	2009937	CAPACITOR—run (w/796251, 2004563)
17	1	1	721033	CAPACITOR—fan (w/720102, 796251, 2004562, 2004563, 2014090)
18	1	1	721034	WHEEL—blower (w/720102, 2004562)
18	1	1	2009940	WHEEL—blower (w/796251, 2004563, 2014090)
19	2	2	2009941	TUBE—cap (w/796251, 2004563, 2014090)
19	1	1	721035	TUBE—cap (w/720102, 2004562)
20	1	1	* 721036	FILTER—air (w/720102, 796251, 2004562, 2004563, 2014090)
20A	1	1	721037	GRILLE—filter (w/720102, 796251, 2004562, 2004563, 2014090)
21	3	3	721038	KNOB—air flow (w/720102, 796251, 2004562, 2004563, 2014090)

FURNISHINGS

KEY 230 260 PART NUMBER

28.004 AIR CONDITIONER—ROOF MOUNTED, DUO—THERM (Cont.)

22	1	1	721039	TEMPLATE—ceiling permanent (w/720102, 796251, 2004562, 2004563, 2014090)
23	1	1	721040	FLASHING—air conditioner roof (w/720102, 796251, 2004562, 2004563, 2014090)
24	1	1	721041	SHROUD—air conditioner roof (w/720102, 2004562)
24	1	1	2009942	SHROUD—air conditioning roof (w/796251, 2004563, 2014090)
—	1	1	790805	PLATE—mounting, roof air
—	1	1	NS	SWITCH ASSY.—overload (SOA) (exc./2014090) (ref. 797164)
—	1	1	2018432	SWITCH ASSY.—overload (w/2014090)
—	1	1	*2013322	FILTER—suction, compressor (w/796251, 793957, 2014090)
—	1	1	2029289	KIT—roor air conditioner mounting bolt

FURNISHINGS

NOTES

FURNISHINGS

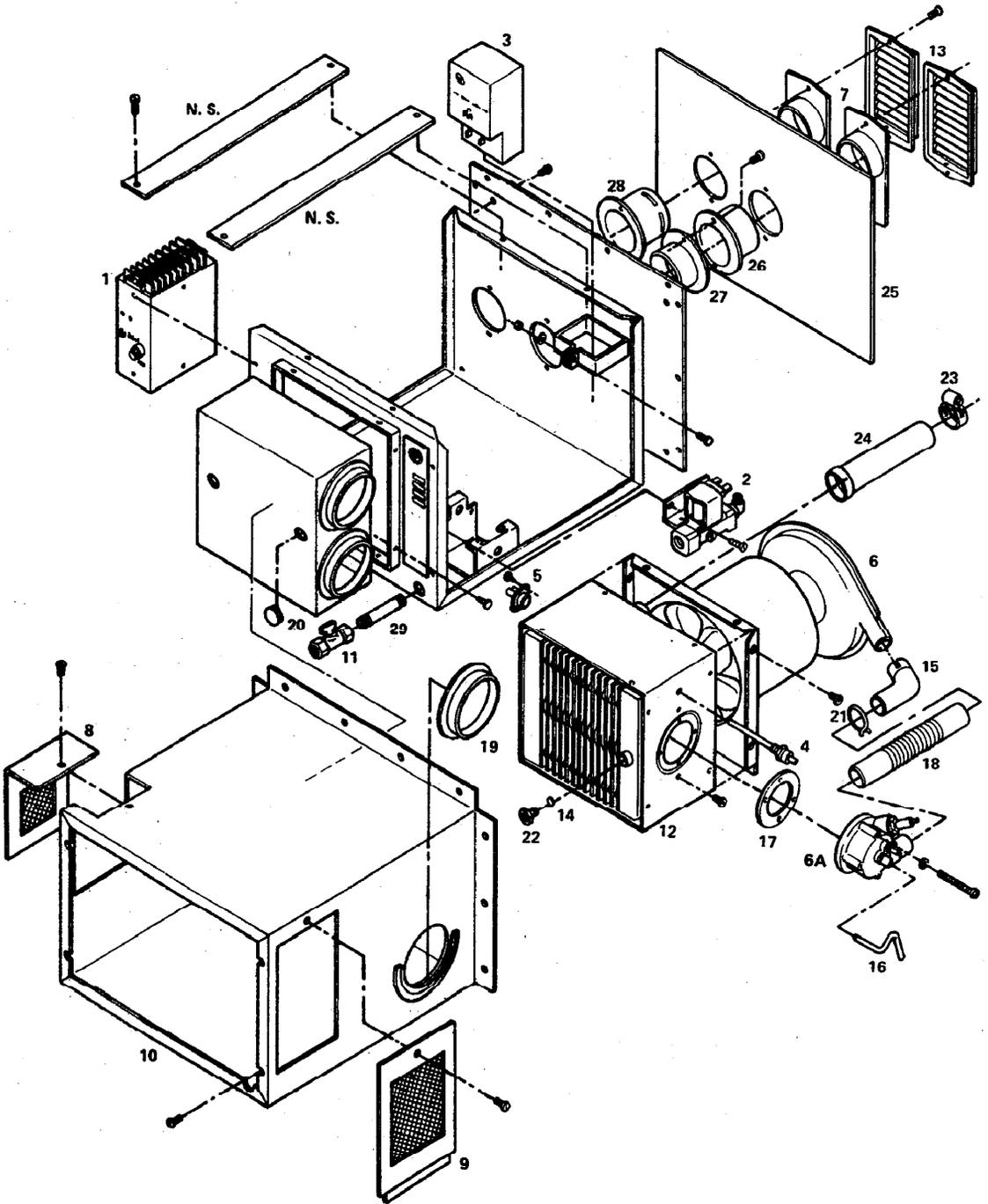

28P-33

28.020 FURNACE - 30,000 BTU, SOL-AIRE

FURNISHINGS

KEY 230 260 PART NUMBER

28.020 FURNACE—30,000 BTU, SOL—AIRE

—	—	1	2005741	FURNACE ASSY.—Tri—Men (30,000 BTU) (complete) (w/ZEO6582, ZEO6584)
—	—	1	790318	FURNACE ASSY.—Tri—Men (30,000 BTU) (complete) (eff. w/1975) (exc./ZEO6582)
1	—	1	791630	BOX ASSY.—DC control (SOA) (w/790318 furnace assy.)
1	—	1	2034551	BOX ASSY.—DC control (SOA) (w/2005741 furnace assy.)
2	—	1	791616	VALVE ASSY.—gas (SOA)
3	—	1	791633	IGNITION PAK ASSY.—(SOA)
—	—	1	791613	CABLE ASSY.—hi tension lead (SOA)
4	—	1	791632	ROD ASSY.—flame (SOA)
5	—	1	791612	SWITCH ASSY.—limit (SOA)
—	—	1	791631	ELECTRODE ASSY.—spark (SOA) (w/790318 furnace assy.)
—	—	1	2034552	ELECTRODE ASSY.—spark (SOA) (w/2005741 furnace assy.)
—	—	1	791628	THERMOSTAT ASSY.—(SOA) (w/790318 furnace assy.)
—	—	1	2030107	THERMOSTAT ASSY.—(SOA) (w/2005741 furnace assy.)
6	—	1	791634	BLOWER ASSY.—(SOA)
6A	—	1	791635	BURNER ASSY.—(SOA)
7	—	2	791624	ADAPTER ASSY.—flue (SOA) (w/790318 furnace assy.)
7	—	1	2034553	ADAPTER ASSY.—flue (SOA) (w/2005741 furnace assy.)
8	—	1	791620	PLATE ASSY.—wiring access
9	—	1	791621	PLATE ASSY.—burner access
10	—	1	791625	CASING ASSY.—outer (SOA)
11	—	1	791618	VALVE ASSY.—manual shut—off
12	—	1	NS	HEAT EXCHANGER ASSY.—heat
13	—	2	791629	CAP—vent
14	—	1	791610	GLASS—sight
—	—	1	791637	FUSE—furnace
—	—	1	791604	FILTER—valve
15	—	1	791614	ELBOW—scroll
16	—	1	791607	TUBE—fuel (w/790318 furnace assy.)
16	—	1	2034555	TUBE—fuel (w/2005741 furnace assy.)
—	—	2	791603	GASKET—vent
17	—	1	791605	GASKET—burner
18	—	1	791608	TUBE—combustion air
—	—	2	791627	STRAP—plenum
19	—	2	791615	FLANGE—outlet
20	—	1	791617	PLUG—dot
21	—	3	791611	CLAMP—duct
22	—	1	791609	RETAINER—sight tube
23	—	1	791606	CLAMP—flue tube
24	—	1	791626	TUBE—flue
25	—	1	791623	PLATE—outside back
26	—	1	791601	PIPE—outer inlet
27	—	1	791602	PIPE—inner inlet
28	—	1	791622	PIPE—exhaust outlet
29	—	1	791619	NIPPLE—shut—off valve
—	—	1	2034556	CONNECTOR—
—	—	1	791125	DECAL—furnace

28.20F FURNACE—30,000 BTU, DUO—THERM

—	—	1	2028332	FURNACE ASSY.—(30,000 BTU) (Duo—therm 65930—946) (complete) (w/ZEO6581) (incl. the following (25) items)
—	1	—	2045210	MOTOR ASSY.—blower (SOA) (3—14331)
—	1	—	2045211	WHEEL—blower (3—12754—002)
—	1	—	2045212	WHEEL—blower (3—14924—001)
—	1	—	2045213	SWITCH ASSY.—sail (SOA) (3—14346)
—	1	—	2045214	SWITCH ASSY.—fan (SOA) (3—12825—001)
—	1	—	2045215	DUCT—flex (3—12742—001)
—	2	—	2045217	RELAY ASSY.—fan (SOA) (3—12812—001)
—	1	—	2045218	CONTROL ASSY.—ignition (SOA) (3—14249)
—	1	—	2045219	SWITCH ASSY.—limit (SOA) (3—12933)
—	1	—	2045220	VALVE ASSY.—regulator (SOA) (3—14246)
—	1	—	2045221	CONTROL ASSY.—gas (SOA) (3—14245)
—	1	—	2045222	MANIFOLD—furnace (3—14279)
—	1	—	2045224	DOOR ASSY.—observation (SOA) (3—14404)
—	1	—	2045223	GASKET—door (3—3456)
—	1	—	2045226	BURNER—main crossover (3—12502)

FURNISHINGS

KEY 230 260 PART NUMBER

28.20F FURNACE—30,000 BTU, DUO—THERM (Cont.)

—	2	—	2045225	BURNER—main (3-12503)
—	3	—	2045228	ORIFICE—burner (6-111255-063)
—	1	—	2045229	IGNITOR ASSY.—furnace (SOA) (3-14267)
—	1	—	2045230	THERMOSTAT ASSY.—wall (SOA) (3-12743-001)
—	1	—	2045231	GASKET—burner cover (3-12586)
—	1	—	2045232	PANEL—front (3-13743)
—	1	—	2045233	LATCH ASSY.—front panel (SOA) (13-9105-001)
—	1	—	2045234	WIRE ASSY.—high voltage (SOA) (3-14312)
—	1	—	2045235	CONNECTOR—side duct (3-12622-002)
—	1	—	2045236	HARNESS ASSY.—wire (SOA) (3-14694)

NOTES

FURNISHINGS

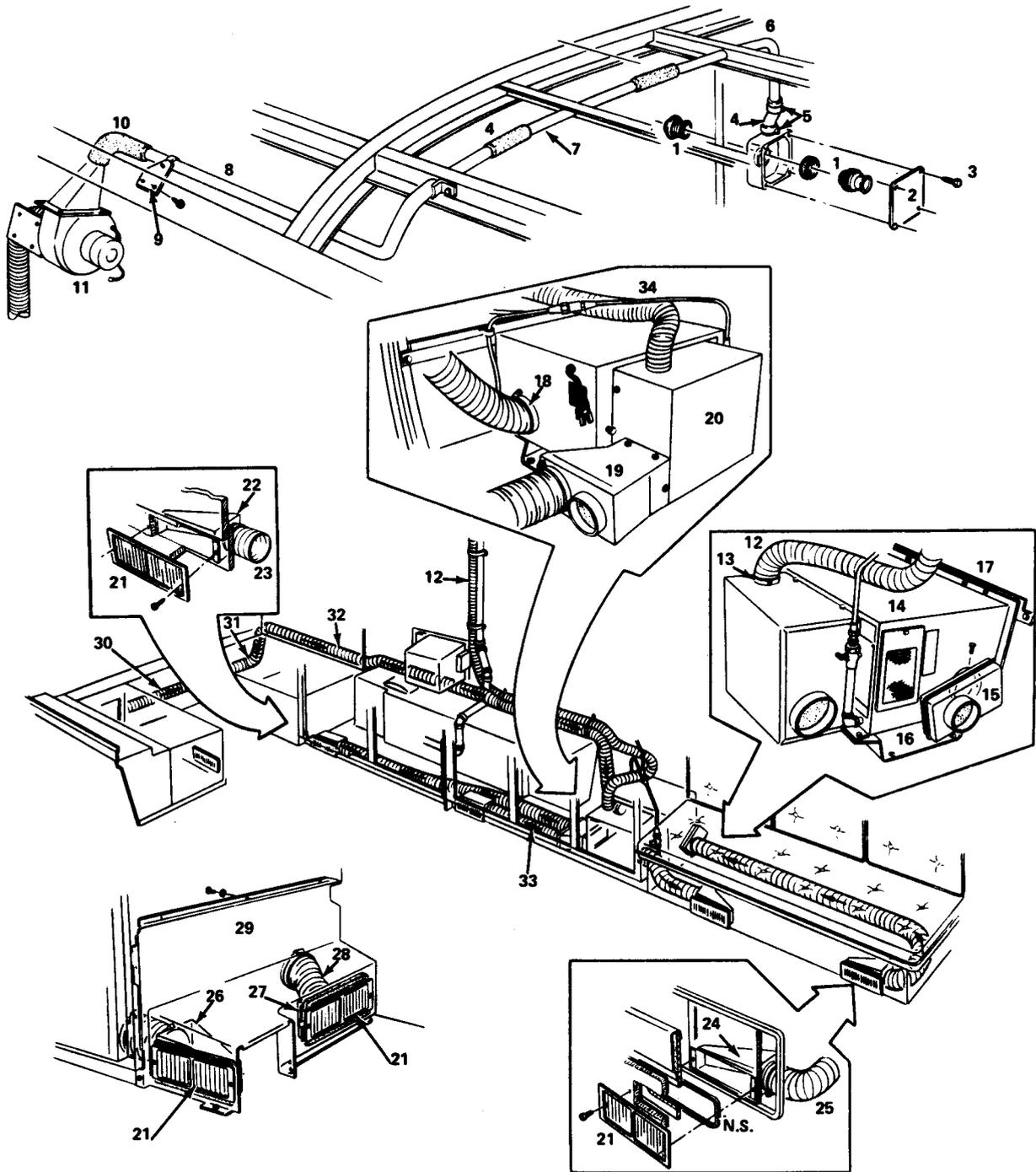

28P-2007

28.023 DUCT - SOL-AIRE 30,000 BTU FURNACE

FURNISHINGS

KEY 230 260 PART NUMBER

28.023 DUCT WORK—SOL—AIRE 30,000 BTU FURNACE (exc. ZE06582, ZE06584)

1	—	1	2455558	OUTLET ASSY.—bath (prior to Serial No. 5V101025)
2	—	1	790184	COVER—outlet (prior to Serial No. 5V101025)
3	—	4	274233	SCREW—cover, bath outlet
4	—	3	792156	HOSE—heat duct (prior to Serial No. 5V101025)
5	—	2	2467789	CLAMP—tube
6	—	1	792160	TUBE ASSY.—(prior to Serial No. 5V101025)
7	—	1	792159	TUBE ASSY.—(prior to Serial No. 5V101025)
8	—	1	792161	TUBE ASSY.—(prior to Serial No. 5V101025)
8	—	2	791737	TUBE—bath module heat duct (eff. w/Serial No. 5V101025)
9	—	1	2001658	CONNECTOR—tube (eff. w/Serial No. 5V101025)
9	—	1	791970	SUPPORT—heat duct (prior to Serial No. 5V101025)
10	—	1	792157	HOSE—heat duct (prior to Serial No. 5V101025)
11	—	1	791724	BLOWER ASSY.—shower module heating fan (eff. w/1975)
11	—	1	793696	MOTOR ASSY.—blower (SOA)
11	—	1	793695	WHEEL ASSY.—blower (SOA)
11	—	1	2236300	CONNECTOR—wire, blower
11	—	1	792158	ADAPTER ASSY.—fan discharge duct at blower (prior to Serial No. 5V101025)
11	—	1	2001978	ADAPTER ASSY.—fan discharge duct at blower (eff. w/Serial No. 5V101025)
11	—	1	2001977	SUPPORT ASSY.—fan mounting (bracket) (eff. w/Serial No. 5V101025)
11	—	1	792162	BRACKET ASSY.—fan mounting (prior to Serial No. 5V101025)
12	—	1	791737	DUCT TUBE—plenum to fan discharge
13	—	2	2468878	CLAMP—plenum to fan discharge tube
14	—	1	—	FURNACE—30,000 BTU (see group 28.020)
15	—	1	791728	ADAPTER ASSY.—cold air duct
16	—	1	791590	BRACKET—furnace mounting, lower
17	—	1	791591	BRACKET—furnace mounting, upper
18	—	AR	2465839	CLAMP—furnace duct tube
19	—	1	791743	TRANSITION ASSY.—plenum duct
20	—	1	792163	PLENUM ASSY.—furnace
21	—	5	791725	REGISTER—air duct
22	—	1	791751	TRANSITION ASSY.—rear discharge air duct
23	—	1	2028114	TUBE—rear discharge air duct (repl. 791738)
24	—	2	791741	TRANSITION ASSY.—air duct, intermediate and below LH Davo (air inlet)
24	—	1	791742	TRANSITION ASSY.—front discharge air duct (below LH Davo)
25	—	AR	2007960	TUBE—furnace ducts, (furnace to transition) (CTL, 3.5" x 216" lg.)
26	—	1	799814	TRANSITION ASSY.—front discharge air duct (LH) outlet (prior to serial No. 6V101292)
26	—	1	2010250	TRANSITION ASSY.—front discharge air duct (LH) outlet (eff. w/serial no. 6V101292)
27	—	1	799815	TRANSITION ASSY.—furnace, air inlet (LH)
28	—	AR	2007960	TUBE—furnace ducts (furnace to transition) (CTL, 3.5" x 216" lg.)
29	—	1	—	PANEL—duct, interior trim (covers transitions) (see group 28.144)
30	—	AR	2007960	TUBE—rear return air duct (CTL, 3.5" x 216" lg.)
31	—	1	791723	CONNECTOR—rear return air duct
32	—	AR	2007960	TUBE—rear return air duct (LH side) (CTL, 3.5" x 216" lg.)
33	—	AR	2007960	TUBE—air duct, intermediate (repl. 791735) (CTL, 3.5" x 216" lg.)
34	—	1	791737	TUBE—plenum to blower (eff. w/Serial No. 5V101025) (CTL) (repl. 2001975)
—	—	1	791726	DUCT—hot air outlet, (housing for plastic outlet assembly No. 245558)
—	—	7	657558	STRAP—air duct (repl. 2435539)
—	—	1	2001663	TRANSITION—bath heat duct (eff. w/Serial No. 5V101025)
—	—	1	2468878	CLAMP—tube to transition (eff. w/Serial No. 5V101025)
—	—	1	2001976	OUTLET—bath heater duct (eff. w/Serial No. 5V101025)
—	—	AR	792762	INSULATION—furnace backing (eff. w/interm 1977)

28.023C DUCT WORK DUO—THERM 30,000 BTU FURNACE (w/ZEO6581)

—	—	1	2028117	ADAPTER—furnace
—	—	1	2028118	ADAPTER—furnace
—	—	1	—	BACKER—air intake & exhaust (ref. 2030323) (make locally)
—	—	1	2029830	SEAL—heat duct outlet
—	—	1	791725	REGISTER—air duct
—	—	1	791751	TRANSITION—front discharge air duct
—	—	1	2007960	TUBE—front and intermediate discharge air duct

FURNISHINGS

KEY 230 260 PART NUMBER

**28.023C DUCT WORK DUO—THERM 30,000 BTU FURNACE (w/ZE06581)
(Cont.)**

—	—	2	2465839	CLAMP—discharge air duct tube
—	—	1	791741	TRANSITION ASSY.—intermediate
—	—	1	791551	TRANSITION ASSY.—rear discharge air duct
—	—	1	2028114	TUBE—rear discharge air duct
—	—	1	791724	BLOWER—shower module heater fan
—	—	1	2001978	ADAPTER ASSY.—fan discharge duct
—	—	1	791737	TUBE—furnace plenum to blower (repl. 2013092)
—	—	2	2468878	CLAMP—furnace plenum to blower tube
—	—	2	791737	TUBE—bath module heat duct
—	—	1	2001658	CONNECTOR—bath module heat duct tube
—	—	2	791156	CLAMP—bath module heat duct tube connector
—	—	2	2468878	CLAMP—bath module heat duct tube connector; bath heat duct transition
—	—	1	2001663	TRANSITION—bath heat duct
—	—	1	2001976	OUTLET—bath heat duct

28.023F DUCT WORK—SOL—AIRE 30,000 BTU FURNACE (w/ZE06582, ZE06584)

—	—	1	791742	TRANSITION ASSY.—return air duct at love seat
—	—	AR	2007960	TUBE—furnace discharge and return (CTL, 3.5" dia. x 216" lg.)
—	—	AR	2465839	CLAMP—tube
—	—	1	2002088	ADAPTER ASSY.—fan discharge duct
—	—	1	791742	TRANSITION ASSY.—discharge air duct at galley
—	—	5	791725	REGISTER—air duct
—	—	AR	2468878	CLAMP—water compartment discharge tube
—	—	1	2008185	CONNECTOR—discharge air duct at water compartment
—	—	1	2008211	TRANSITION ASSY.—discharge, air duct at shower
—	—	1	2007974	TRANSITION ASSY.—discharge, air duct at dresser
—	—	1	791741	TRANSITION ASSY.—return air duct to bed
—	—	1	2001663	TRANSITION—bath heat duct (w/ZE06584)
—	—	1	2001976	OUTLET—bath heat duct (w/ZE06584)
—	—	1	791724	BLOWER—furnace auxiliary fan (w/ZE06584)
—	—	AR	791737	TUBE—discharge, shower transition to vanity transition (CTL, 124" lg.) (repl. 2007962) (w/ZE06582)
—	—	1	2008255	SUPPORT ASSY.—blower motor (incl. next [2] items)
—	—	1	2008409	TUBE—blower motor
—	—	1	2008410	BRACKET—blower motor
—	—	1	2008149	BRACKET—support, blower motor
—	—	1	791590	BRACKET—furnace mounting, lower
—	—	1	791591	BRACKET—furnace mounting, upper
—	—	1	3980590	SCREW—furnace lower mounting bracket to floor
—	—	7	657558	STRAP—air duct tube
—	—	1	—	SUPPORT—transition, heating (procure locally) (w/ZE06582) (ref. 2009866)

FURNISHINGS

NOTES

FURNISHINGS

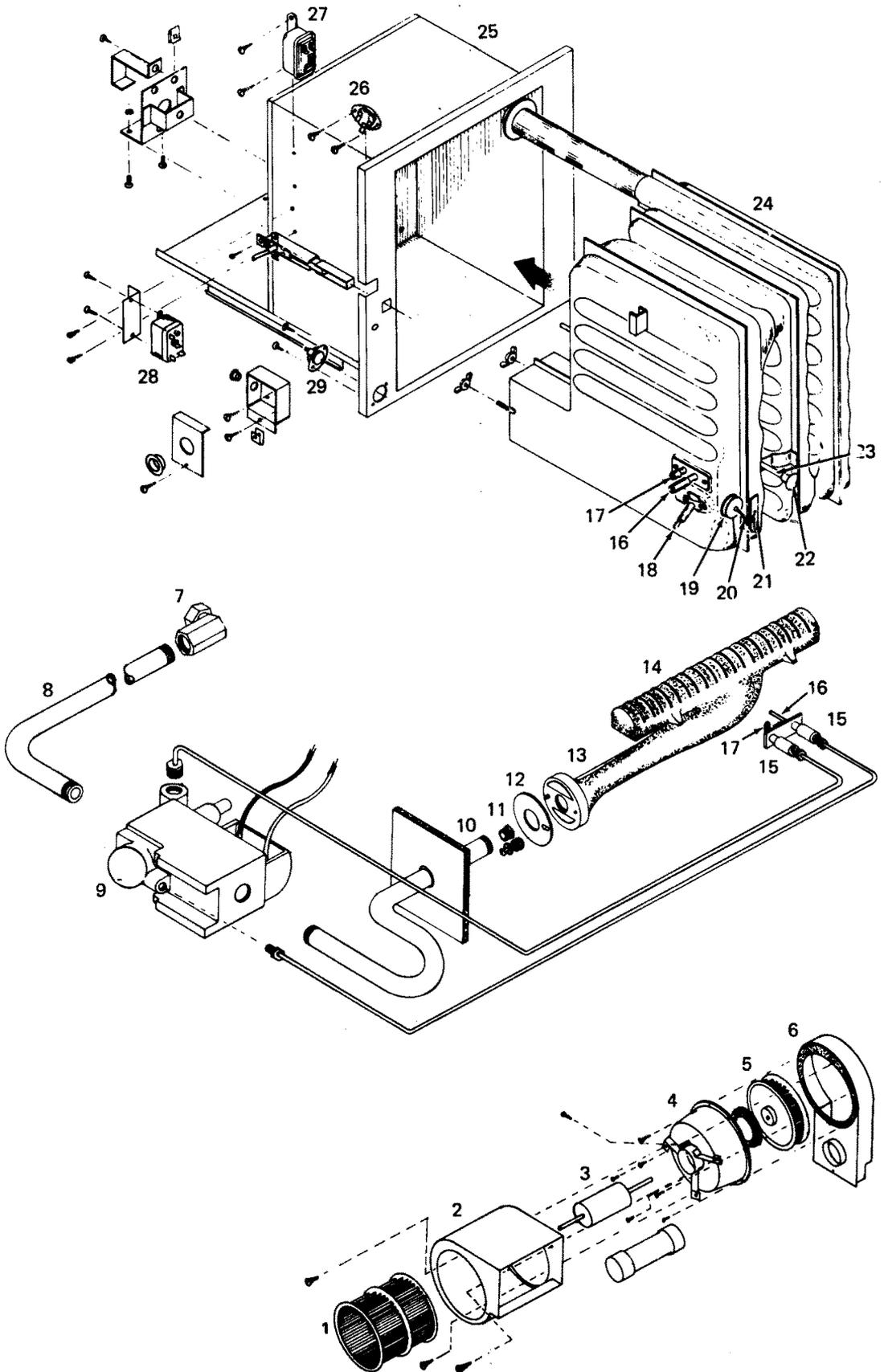

28.028 FURNACE - 30,000 BTU, SUBURBAN (FIRST DESIGN)

3P-8020

FURNISHINGS

KEY 230 260 PART NUMBER

28.028 FURNACE—30,000 BTU, SUBURBAN (FIRST DESIGN)

—	—	—	703802	FURNACE ASSY.—NT32G dyna—trail (30,000 BTU) (complete) (for ref. only) (First Design)
1	1	1	703845	WHEEL—blower, large
2	1	1	703841	HOUSING—blower
3	1	1	703843	MOTOR—blower (Bosch)
4	1	1	703847	MOUNT—blower motor
5	1	1	703846	WHEEL—blower, small
6	1	1	703848	COVER—air intake, blower motor
7	1	1	703834	FITTING—tetrad, burner
8	1	1	703852	PIPE—burner, basotrol
9	1	1	703844	VALVE—burner, basotrol
10	1	1	703851	PIPE—manifold, burner
11	1	1	703850	ORIFICE—main burner No. 53 (drilled)
12	1	1	703830	SHUTTER—air burner
13	1	1	703828	ROD—air shutter
14	1	1	703849	BURNER—main
15	2	2	703829	ORIFICE—pilot burner (.007)
16	2	2	703814	THERMOCOUPLE—burner & combustion chamber
17	2	2	703815	BURNER—pilot, burner & combustion chamber
18	1	1	713684	ELECTRODE—combustion chamber (repl. 703837)
19	1	1	703816	CAP—lighter, combustion chamber
20	1	1	703817	CHAIN—lighter, combustion chamber
21	1	1	703826	COVER—air shutter adjustment
22	1	1	703819	KNOB—pilot reset
23	1	1	703827	ROD—control reset
24	1	1	703840	CHAMBER ASSY.—combustion
25	1	1	NS	WRAPPER—radiation shield
26	1	1	703807	SWITCH ASSY.—fan (145 degrees) (SOA)
27	1	1	703806	RELAY—thermostat PBM150
28	1	1	NPN	RELAY—AC/DC switching
29	1	1	703808	SWITCH ASSY.—limit (170 degrees) (SOA) (First Design)
29	1	1	715409	SWITCH ASSY.—limit (170 degrees) (SOA) (Second Design)
—	1	1	703842	SWITCH ASSY.—micro, incl. paddle (SOA)
—	1	1	703809	IGNITOR ASSY.—impact (SOA)

FURNISHINGS

KEY 230 260 PART NUMBER

28.028A FURNACE—CHAMBER AND BURNER ASSEMBLY (SUBURBAN) (SECOND DESIGN)

—	1	1	713649	FURNACE ASSY — 22000 BTU DYNATRIL NT—22G (Second Design) (replaces 703801) (ref. only)
—	1	1	713650	FURNACE ASSY.—30000 BTU DYNATRIL NT—32G (Second Design) (replaces 703802)
1	1	1	703807	SWITCH—fan 145 degrees
2	1	1	NS	BRACKET
3	1	1	713664	SWITCH—limit 210 degrees
4	1	1	703809	IGNITOR—impact
5	1	1	713679	ROD—lighter
6	1	1	703819	KNOB—pilot reset (black)
7	1	1	703815	BURNER—pilot
8	1	1	NS	BRACKET—electrode
9	1	1	NS	GASKET—pilot mounting
10	1	1	713684	ELECTRODE
11	1	1	713702	GASKET—electrode
12	1	1	703816	CAP—lighter (solid)
12	1	1	713718	CAP—lighter (mica)
13	1	1	713701	GASKET—air shutter cover
14	1	1	703826	COVER—air shutter adjustment
15	1	1	703803	CHAMBER ASSY.—combustion — 22,000 BTU - 3 chambers
15	1	1	703840	CHAMBER ASSY.—combustion — 30,000 BTU - 5 chambers
16	1	1	703806	RELAY—thermostat
17	1	1	—	ELBOW—brass 90 (procure locally)
18	1	1	—	PIPE—manifold (procure locally)
19	1	1	713673	ORIFICE—main burner — 22,000 BTU (Second Design)
19	1	1	703850	ORIFICE—main burner — 30,000 BTU
20	1	1	703830	SHUTTER—burner air
21	1	1	703825	BURNER—main — 22,000 BTU
21	1	1	703849	BURNER—main — 30,000 BTU
22	1	1	713704	VALVE—basotrol
23	1	1	799740	KIT—tube (SOA) (repl. 713706 & 713708)
24	1	1	713711	FITTING—elbow
25	1	1	713705	VALVE—manual shut—off
26	1	1	703831	REGULATOR—pilot
27	1	1	703828	ROD—air shutter
28	1	1	703829	ORIFICE—pilot (.007)
29	1	1	713665	THERMOCOUPLE
30	1	1	713707	TUBING—pilot

FURNISHINGS

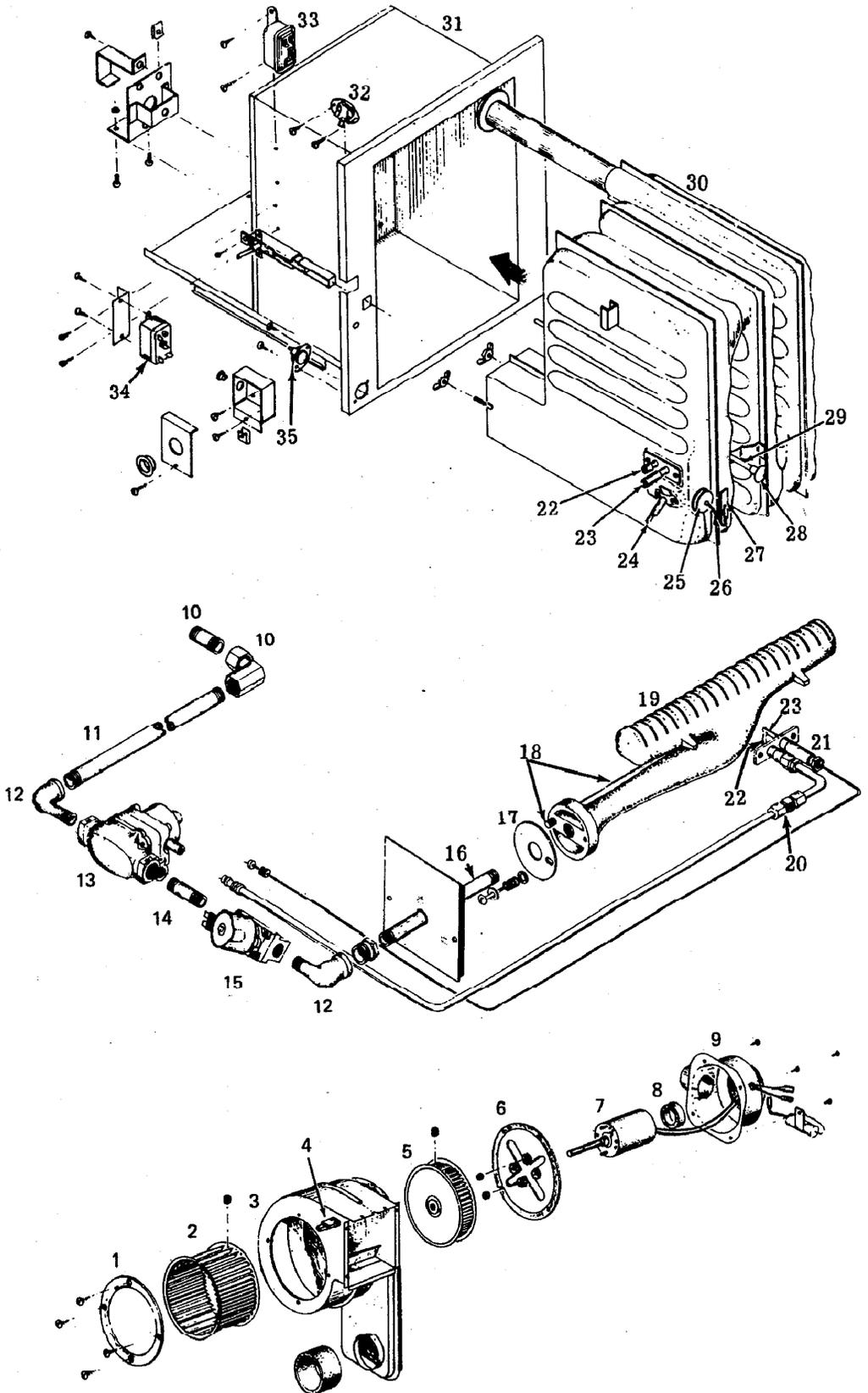

FURNISHINGS

KEY 230 260 PART NUMBER

28.029 FURNACE—22,000 BTU, SUBURBAN

—	—	—	703801	FURNACE ASSY.—NT22G DYNATRIL (22,000 BTU) (First Design) (ref. only)
—	—	—	713649	FURNACE ASSY.—DYNATRIL (Second Design) (ref. only)
1	1	1	703823	RING—inlet, blower
2	1	1	703820	WHEEL—blower, large
3	1	1	703804	HOUSING—blower
4	1	1	703805	SWITCH ASSY.—micro, incl. paddle (SOA)
5	1	1	703821	WHEEL—blower, small
6	1	1	703822	PLATE—divider, blower
7	1	1	703810	MOTOR—blower (1450 RPM) (BOSCH)
8	2	2	703824	BUSHING—blower & burner
9	1	1	703818	COVER—air intake, blower motor
10	1	1	703834	FITTING—tetrad, blower
11	1	1	703833	PIPE—burner (blackiron)
12	2	2	—	ELBOW—burner 3/8 x 90 street (procure locally)
13	1	1	NPN	PILOT—safety No. TS11-K
14	1	1	—	NIPPLE—burner 3/8" x 1 1/2" (procure locally)
15	1	1	713704	VALVE—solenoid, alpha (SOA)
16	1	1	703832	PIPE—manifold 1/4", burner
17	1	1	703830	SHUTTER—air, burner
18	1	1	703828	ROD—air shutter
19	1	1	703825	BURNER—main
20	1	1	703831	REGULATOR—pilot, burner
21	1	1	703829	ORIFICE—pilot burner (.007)
22	2	2	703815	BURNER—pilot (w/burner & combustion chamber)
23	2	2	703814	THERMOCOUPLE—(w/burner & combustion chamber)
24	1	1	713684	ELECTRODE—combustion chamber (repl. 703837)
25	1	1	703816	CAP—lighter, combustion chamber
26	1	1	703817	CHAIN—lighter, combustion chamber
27	1	1	703826	COVER—air shutter adjustment
28	1	1	703819	KNOB—pilot reset (black)
29	1	1	703827	ROD—reset control
30	1	1	703803	CHAMBER ASSY.—combustion
31	1	1	NS	WRAPPER—radiation
32	1	1	703807	SWITCH ASSY.—fan (145) (SOA)
33	1	1	703806	RELAY—thermostat
34	1	1	NPN	RELAY—AC/DC switching
35	1	1	703808	SWITCH ASSY.—limit (195) (SOA)
—	1	1	703809	IGNITOR ASSY.—impact (SOA)

FURNISHINGS

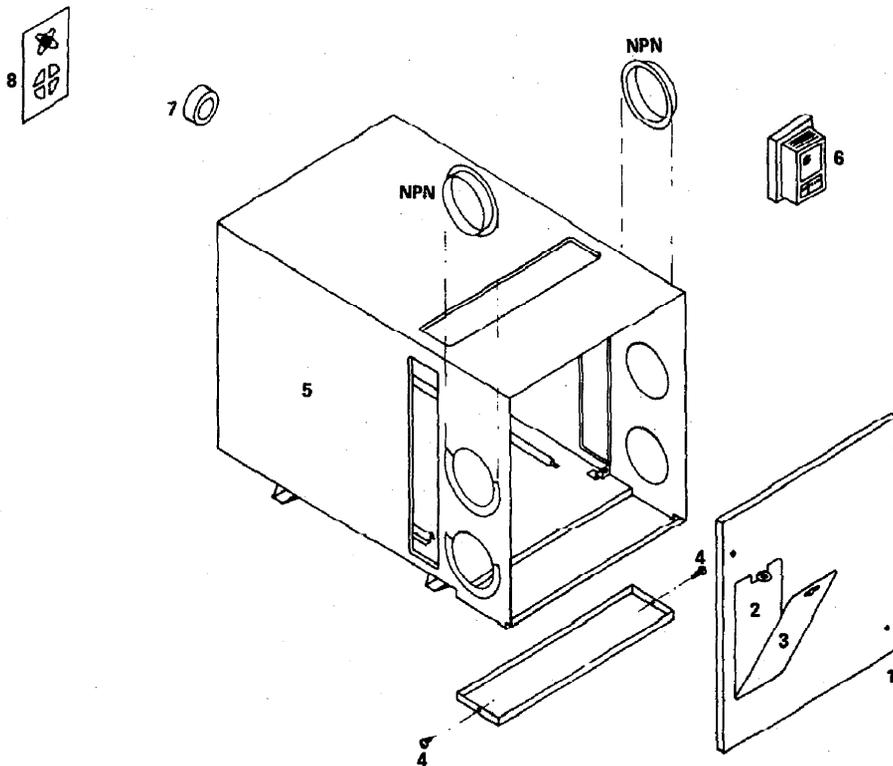

28P-2002

KEY 230 260 PART NUMBER

28.029A CABINET—SUBURBAN FURNACE

1	1	1	NS	FRONT—main cabinet
2	1	1	703838	LATCH—door
3	1	1	703839	DOOR—main cabinet, front (First Design)
3	1	1	713700	DOOR—main cabinet, front (Second Design)
4	1	1	—	SCREW—hold down # 8 x 1 (procure locally)
5	1	1	NS	CABINET ASSY.—outer
6	1	1	703813	THERMOSTAT ASSY.—(SOA) (prior to 1975)
6	—	1	2030107	THERMOSTAT ASSY.—(SOA) (w/Sol-Aire furnace) (eff. w/1975) (repl. 791628)
7	1	1	703836	ADAPTER—vent cap
8	1	1	703835	CAP—vent

NOTES

FURNISHINGS

KEY 230 260 PART NUMBER

28.029B BLOWER—SUBURBAN FURNACE

1	1	1	703823	RING—inlet (22000 BTU)
2	1	1	703820	WHEEL—blower, large (22000 BTU)
2	1	1	703845	WHEEL—blower, large (32000 BTU)
3	1	1	713703	COVER—micro switch (22000 BTU)
4	1	1	713651	SWITCH—micro, incl. paddle (22000 BTU)
5	1	1	713709	TUBE—crossover, rubber (22000 BTU)
5	1	1	713714	TUBE—crossover, rubber (32000 BTU)
6	1	1	703804	HOUSING—blower (22000 BTU)
6	1	1	703841	HOUSING—blower (32000 BTU)
7	1	1	703821	WHEEL—blower, small (22000 BTU)
7	1	1	703846	WHEEL—blower, small (32000 BTU)
8	1	1	703822	PLATE—blower divider (22000 BTU)
9	1	1	703810	MOTOR—blower (BOSCH) (22000 BTU)
9	1	1	703843	MOTOR—blower (BOSCH) (32000 BTU)
10	1	1	713710	CUP—vacuum (22000 BTU)
11	1	1	713669	COVER—air intake blower motor (22000 BTU)
11	1	1	713713	COVER—air intake blower motor (32000 BTU)
11A	1	1	703848	COVER—air intake blower motor (32000 BTU)
12	1	1	703824	BUSHING—blower and burner
13	AR	AR	NPN	SCREW

FURNISHINGS

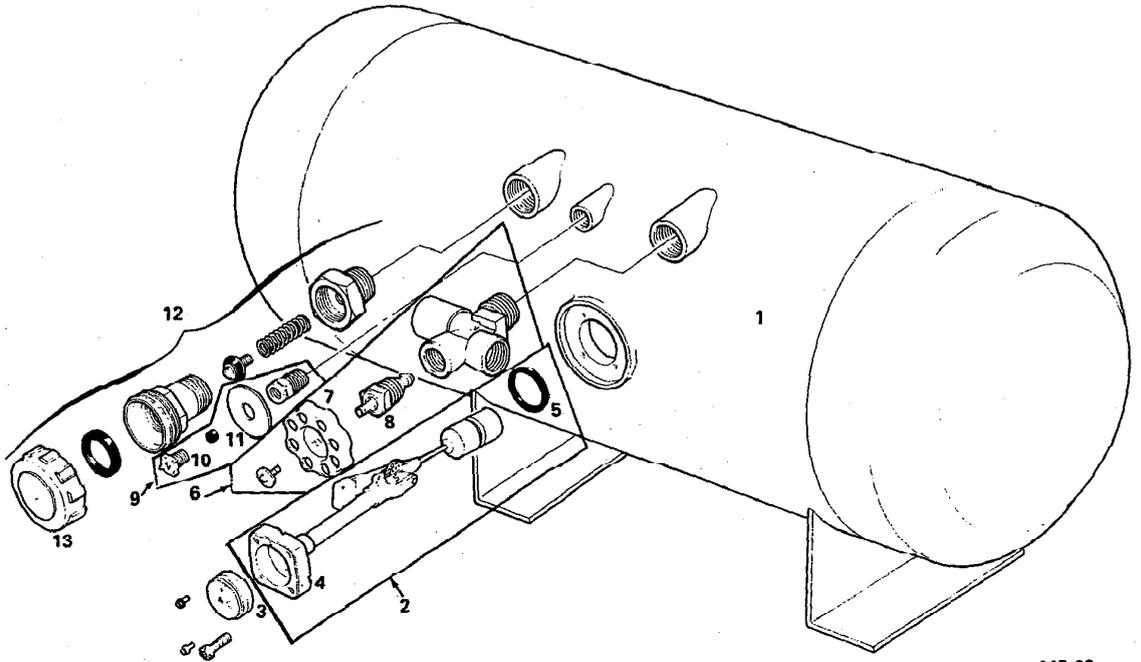

28P-23

28.030 TANK - L.P.G. (INCLUDES VALVES)

FURNISHINGS

KEY 230 260 PART NUMBER

28.030 TANK—L.P.G. (INCLUDES VALVES)

1	1	1	703506	TANK ASSY.—liquid propane gas (30 inches) (42.5 lb.)
1	—	1	703507	TANK ASSY.—liquid propane gas (40 inches) (62 lb.) (ref. only) (Frist Design) (No. 703506 & 703507)

NOTE: The above listed tanks (703506 & 703507) use the following 12 parts.

2	1	1	703511	GUAGE ASSY.—gas tank float (mounts on L.P. tank) (replacement gauge does not include dial customent must order—1—706918 when replacing 703511)
3	1	1	706918	DIAL—gas tank sight/transmitter (repl. 706919) (mounts on dash) (to be used when replacing 703511 gauge)
4	1	1	706914	BODY—float gauge
5	1	1	706915	GASKET—float gauge body
6	1	1	703510	VALVE ASSY.—vapor pol
7	1	1	706912	HANDLE—vapor pol valve
8	1	1	706913	STEM—vapor pol valve
9	1	1	703509	VALVE ASSY.—liquid level outage
10	1	1	NS	SEAT—outage valve (ref. 706909)
11	1	1	706910	DIAL—stop fill
12	1	1	703508	VALVE ASSY.—3/4 inch fill
13	1	1	706911	CAP—tank fill valve
—	—	1	2005737	TANK ASSY.—liquid propane gas (Second Design)
—	—	1	2011557	VALVE ASSY.—high flow service (SOA) (used w/2005737 tank only)
—	—	1	2011558	VALVE ASSY.—tank fill (SOA) (used w/2005737 tank only)
—	—	1	2011559	GUAGE ASSY.—liquid level outage (SOA) (w/overflow) (used w/2005737 tank only)
—	—	1	2011560	GUAGE ASSY.—tank sight (SOA) (w/connection to monitor panel) (used w/2005737 tank only)
—	—	1	2024082	SENDING UNIT—90 OHM SOA (used w/2005737 tank only)
—	1	1	790396	VALVE ASSY.—LP gas regulator (prior to 1978)
—	1	1	2036718	VALVE ASSY.—LP gas regulator (1978) (repl. 2033014)
—	1	1	790833	HOSE ASSY.—LP gas tank to floor
—	—	1	792192	HOSE—flexible, LPG (eff. w/1975)
—	—	1	792193	HOSE—flexible, rubber, LPG (eff. w/1975)
—	—	1	792194	TUBE—LPG, 5/8", compartment to frame (eff. w/1975)
—	—	1	—	SHIELD—LPG, line (procure locally) (eff. w/1975) (ref. 2002983)
—	—	2	666138	CLAMP ASSY.—shield to tube (eff. w/1975)
—	—	1	792196	TUBE—LPG, 5/8", main flame line (eff. w/1975) (prior to Serial No. 6V100878)
—	—	1	2008201	TUBE ASSY.—LPG, rear (eff. w/Serial No. 6V100878)
—	—	1	792198	TUBE—LPG, 5/8", bulk connector to tee above floor (eff. w/1975)
—	—	1	792199	TUBE—LPG, 3/8", tee to range (eff. w/1975) (prior to 1978) (exc./ZEO6582, ZEO6584)
—	—	1	—	TUBE—LPG, 3/8", tee to range (1978) (w/ZEO6581) (ref. 2028120) (procure locally)
—	—	1	2008264	TUBE ASSY.—LPG, tee to range (w/ZEO6582, ZEO6584)
—	—	1	2027033	TUBE ASSY.—LPG, tee to range (w/RPO 685) (eff. w/1977)
—	—	1	3786405	GROMMET—LPG, tube to range
—	—	1	—	ELBOW—LPG to range (procure locally) (ref. 9409816)
—	—	2	117219	REDUCER—LPG tube (eff. w/1975)
—	—	1	792200	TUBE—LPG, 3/8", tee to floor (eff. w/1975)
—	—	1	792191	TEE—LPG (eff. w/1975)
—	—	1	9409840	UNION—swivel, LPG (eff. w/1975)
—	1	1	2032708	TAG—LP gas, decal ("LP gas system, etc.—") (repl. 7916886)
—	—	2	NPN	BRACKET—support, LP tube (eff. w/1975) (ref. 792711) (make locally)
—	—	2	NPN	PLATE—mounting regulator hose (eff. w/1975) (ref. 790057) (make locally)
—	—	2	2215842	COUPLING ASSY.—elbow to bulkhead (eff. w/1975)
—	—	1	3866188	CLIP—LPG tube to range (eff. w/1975)
—	—	1	2419766	CLAMP—LPG hose to frame
—	—	5	NPN	CLIP—LPG tube to frame (repl. 2493419)
—	—	1	719178	CLIP—LP tube
—	—	4	2026823	CLIP—LP tube
—	—	6	2390893	CLIP—LP tube (repl. 2488390)
—	—	1	2027013	TUBE ASSY.—LP gas rear rear
—	—	1	792193	HOSE—LP gas rear rear tube to rear tube
—	—	1	2026824	BRACKET—LP gas rear hose
—	—	1	2027015	TUBE ASSY.—LP gas rear

FURNISHINGS

KEY 230 260 PART NUMBER

28.030 TANK—L.P.G. (INCLUDES VALVES) (Cont.)

—	—	1	2027011	TUBE ASSY.—LP gas at bulkhead
—	—	1	—	COVER ASSY.—tank (see group 23.065)
—	—	1	2027855	LABEL—LPG tank menthyl alcohol (cold weather operation)

FURNISHINGS

NOTES

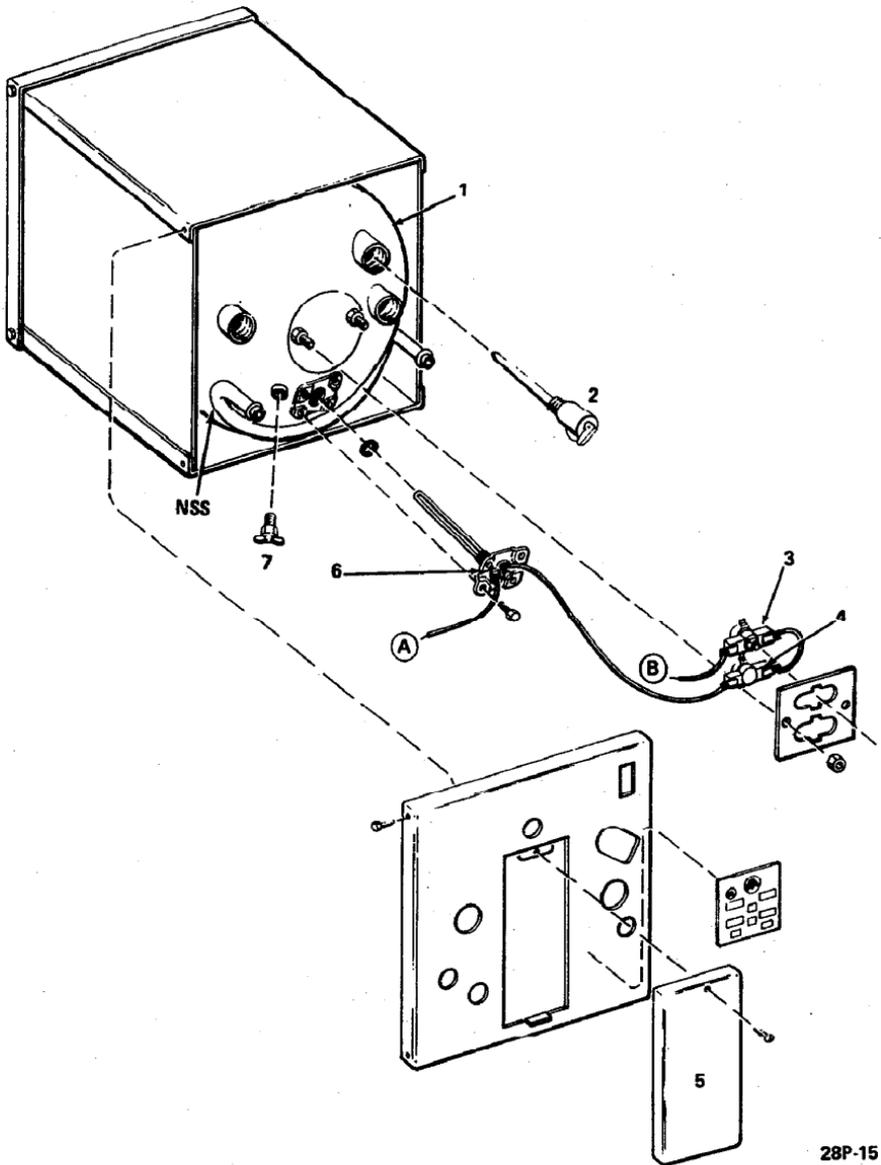

28P-15

28.034 HEATER - WATER (FIRST DESIGN)

FURNISHINGS

KEY 230 260 PART NUMBER

28.034 HEATER—WATER (FIRST DESIGN)

—	1	1	707465	HEATER ASSY.—water (1000 watt electric) (complete) (incl. next 8 items)
1	1	1	707466	TANK ASSY.—inner
2	1	1	707470	VALVE ASSY.—relief, temperature and pressure
3	1	1	707468	CONTROL ASSY.—thermostat
4	1	1	707469	CONTROL ASSY.—high temperature
5	1	1	707471	COVER—access
6	1	1	707467	ELEMENT ASSY.—heat (incl. gasket)
7	1	1	NPN	COCK—drain (1/8 thd.) (procure locally)
—	1	1	707472	GASKET—heat element
—	1	1	2464966	TEE—water heater return hose
—	1	1	698319	CLIP—feed and return hose (rolled edge type)
—	—	16	2468869	CLAMP—hot water tank
—	1	1	791687	TAG—water heater switch
—	AR	AR	711541	TEE—water pump hose to return hose
—	—	1	796778	VALVE—check, hot water tank to pump
—	—	1	444044	ELBOW—inlet, hot water tank
—	—	2	—	SPACER—hot water tank (make locally) (w/ZEO6582) (ref. 2007419)
—	—	AR	2224567	TUBE—hot water drain tank (repl. R32600) (9/32" ID x 1/2 OD x 39") (CTL) (w/ZEO6582, ZEO6584)
—	—	AR	9433154	HOSE—hot water safety valve (repl. R34825) (25' roll, CTL) (w/ZEO6582, ZEO6584)
—	—	1	455946	BUSHING—hot water safety valve (w/ZEO6582, ZEO6584)

FURNISHINGS

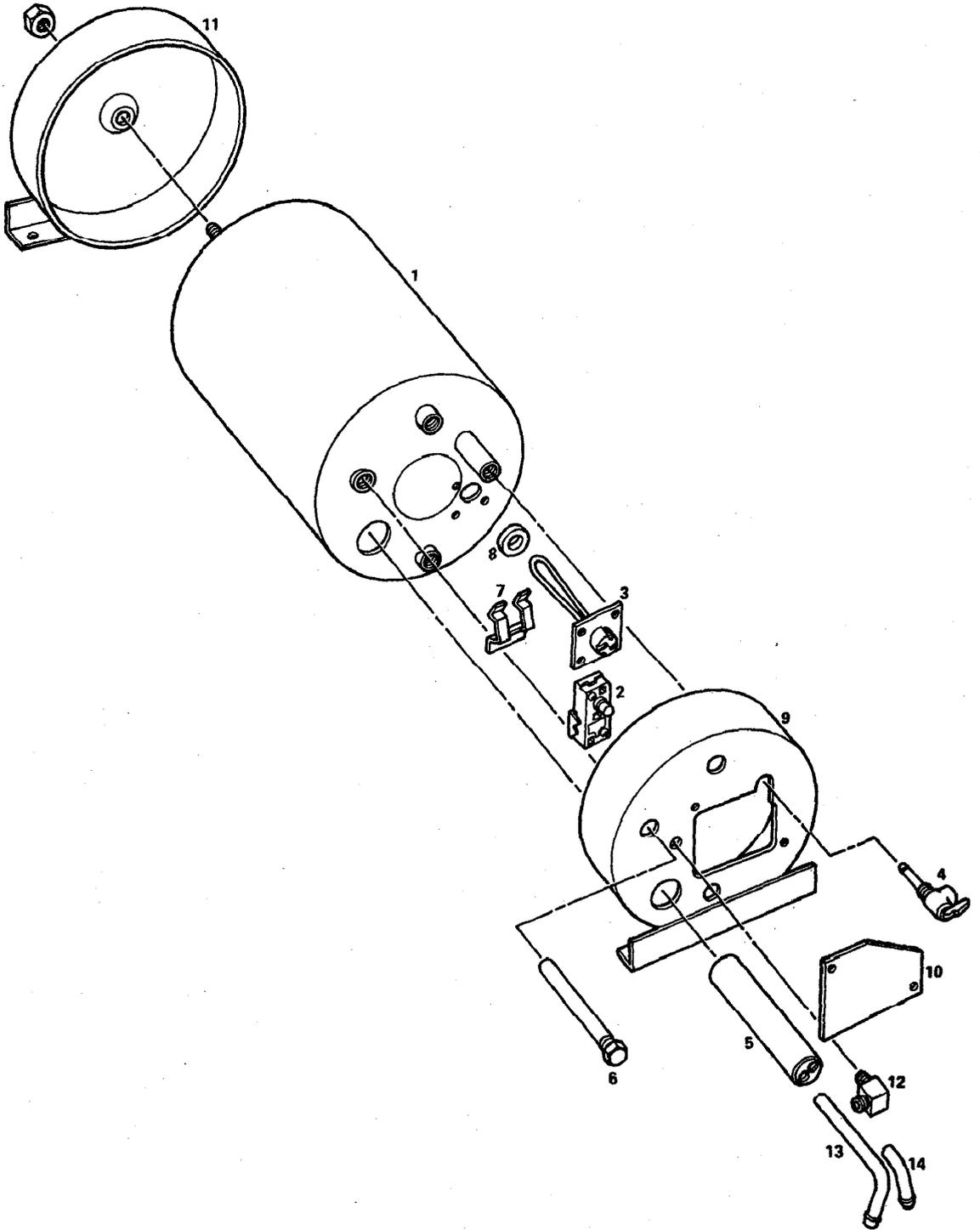

28P-43-177

28.034J HEATER - WATER (SECOND DESIGN)

28-34

FURNISHINGS

KEY 230 260 PART NUMBER

28.034J HEATER-WATER (SECOND DESIGN)

1	1	1	2005305	HEATER ASSY.—water (complete) (12" dia.) (Second Design) (exc./ZE06584)
1	—	1	2024848	TANK ASSY.—water heater hot water (w/ZE06584) (eff w/interm 1977, w/aluminum vent nipples) (details not available at time of publication)
1	—	1	2006742	TANK ASSY.—inner (w/2005305 heater) (exc./ZE06584) (prior to interm 1977, w/plastic vent nipples)
1	—	1	2006740	EXCHANGER ASSY.—heater (w/2005305 heater (preheat) (exc./ZE06584) (prior to interm 1977, w/2006742 tank assy.)
2	—	1	2007713	THERMOSTAT ASSY.—heater (SOA) (w/2005305 water heater) (prior to interm 1977, w/2006742 tank assy.)
2	—	1	2029906	THERMOSTAT ASSY.—heater (SOA) (eff. w/interm 1977, w/2005305 water heater)
3	—	1	2007714	ELEMENT ASSY.—heating (SOA) (w/2005305 water heater)
4	—	1	2007717	VALVE ASSY.—pressure (SOA) (w/2005305 water heater)
5	—	1	2041858	AID ASSY.—motor (SOA) (w/2005305 water heater) (repl. 2007718)
6	—	1	2007720	ROD—arode (w/2005305 water heater)
7	—	1	2007721	BRACKET—thermo (w/2005305 water heater)
8	—	1	2007723	GASKET—element (w/2005305 water heater)
9	—	1	2007724	HOUSING—control, front (w/2005305 water heater)
10	—	1	2007725	DOOR—access (w/2005305 water heater)
11	—	1	2007726	DOOR—rear (w/2005305 water heater)
12	—	1	2007727	ELBOW—conduit, 1/2 inch (w/2005305 water heater)
13	—	1	NS	TUBE—motor aid heat exchanger straight (w/2005305 water heater)(use 2041858)
14	—	1	2021865	TUBE—motor aid heat exchanger bent (w/2005305 water heater)
—	—	16	2468869	CLAMP—hot water tank
—	—	1	444044	ELBOW—inlet, hot water tank
—	—	AR	2224567	TUBE—hot water drain tank (repl. R32600) (9/32" I.D. x 39" CTL)
—	—	AR	9433154	HOSE—hot water safety valve (repl. 34825) (25' roll ctl)

28.038 GAUGE—HOLDING TANK (PANEL)

—	1	1	—	GAUGE—holding tank (exc./ZE06582) (see group 28.040)
—	—	1	2006796	GAUGE—holding tank (w/ZE06582) (details not available at time of publication)

28.039 SENDING UNIT—HOLDING TANK

—	1	1	6429634	SENDER ASSY.—holding unit (repl. 6429587)
—	1	1	1516395	GASKET—sender unit
—	1	1	6429637	GASKET—holding tank sender
—	1	1	2987004	WIRE—ground, sending unit (use w/6429587 sender)
—	2	2	—	NUT ASSY.—wire to sending unit (repl. 271169) (use w/6429587 sender) (procure locally)
—	2	2	—	WASHER—wire to sending unit (procure locally) (ref. 138479)

FURNISHINGS

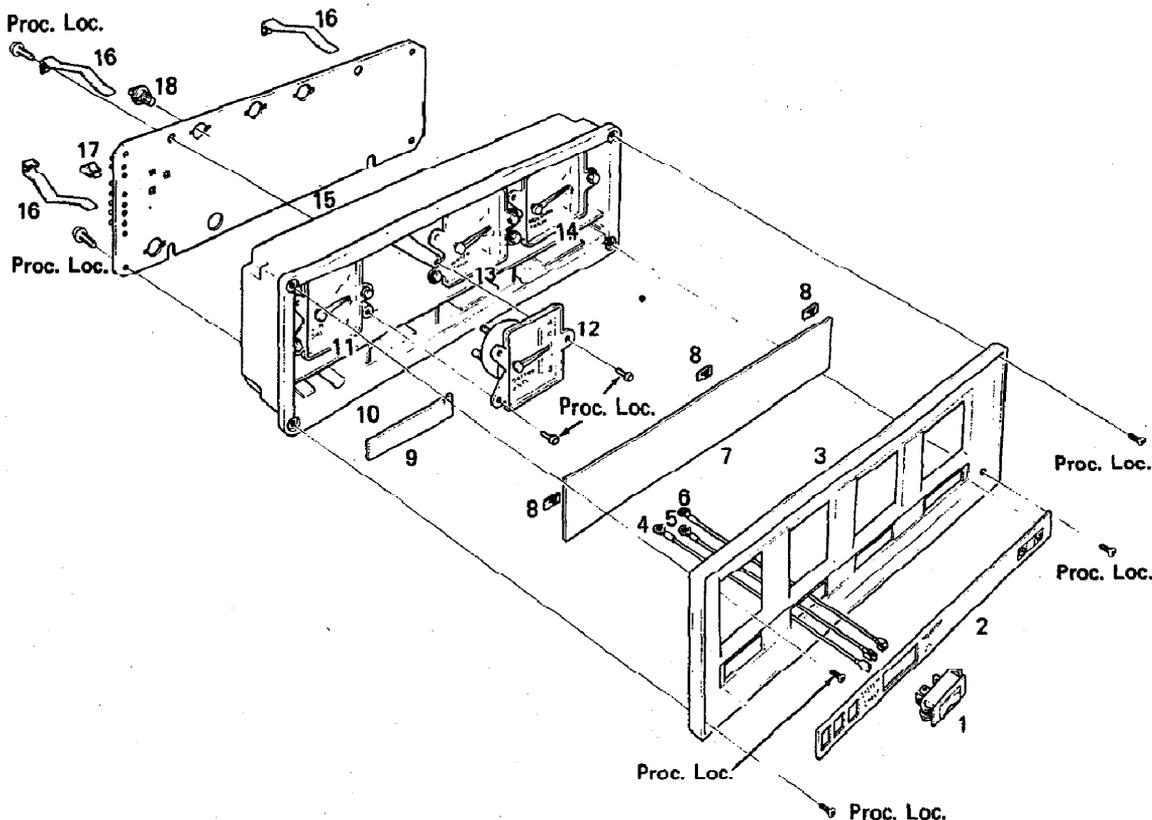

3P-14005

KEY 230 260 PART NUMBER

28.040 PANEL—MONITOR

—	1	1	8985038	PANEL ASSY.—monitor (complete)
1	1	1	6499902	SWITCH—monitor panel (3 prong)
2	1	1	NS	APPLIQUE—monitor panel
3	1	1	8985187	BEZEL—instrument cluster
4	1	1	—	WIRE ASSY.—monitor switch — off position (make locally)
5	1	1	—	WIRE ASSY.—monitor switch — feed (make locally)
6	1	1	—	WIRE ASSY.—monitor switch — on position (make locally)
7	1	1	8985188	LENS—instrument cluster and monitor panel
8	3	3	6481318	NUT—push
9	1	1	8985135	FILTER—tell tale
10	1	1	NS	CASE—instrument cluster and monitor panel
11	1	1	6431789	GAUGE—LP gas
12	1	1	6474099	VOLTMETER (prior to 1978)
12	1	1	6473717	VOLTMETER—(w/RPO LO4) (1978)
13	1	1	6431790	GAUGE—water tank
14	1	1	6431791	GAUGE—holding tank (see group 28.038 for gauge w/ZE06582)
15	1	1	6499906	BOARD—circuit
16	4	4	6499910	CLIP—spring, circuit board to instrument case
17	12	12	6496641	CLIP—circuit board to instrument case
18	4	4	6456923	SOCKET—lamp (repl. 6457224)
18	4	4	9421330	BULB—(repl. 6457224)
—	3	3	6497106	GASKET—tell tale filter

FURNISHINGS

KEY 230 260 PART NUMBER

28.042 LINES—MOTOR GENERATOR FUEL

—	1	1	3744155	ELBOW—fuel hose
—	AR	AR	9432787	HOSE—fuel (25', CTL) (prior to 1977)
—	—	1	9436889	HOSE—motor generator fuel inlet (eff. w/1976)
—	—	AR	2224546	LOOM—motor generator fuel inlet hose (eff. w/1976)
—	—	1	9436889	SUCTION HOSE—fuel, motor generator
—	2	2	2468869	CLAMP—hose
—	3	3	2397582	CLIP—hose (spring type)
—	1	1	5168001	CLIP—fuel hose (hair pin type) (repl. 5151108)
—	2	2	3866188	CLIP—fuel hose (clamp type) (repl. 3941477)
—	1	1	719177	CLIP—fuel hose (w/RPO NRE)
—	1	1	676543	STRAP ASSY.—fuel hose
—	1	1	797242	VALVE ASSY.—solenoid, fuel line (4KW and 6KW ONAN) (SOA)
—	2	2	2436165	WASHER—bolt, fuel hose (w/RPO NRE)

FURNISHINGS

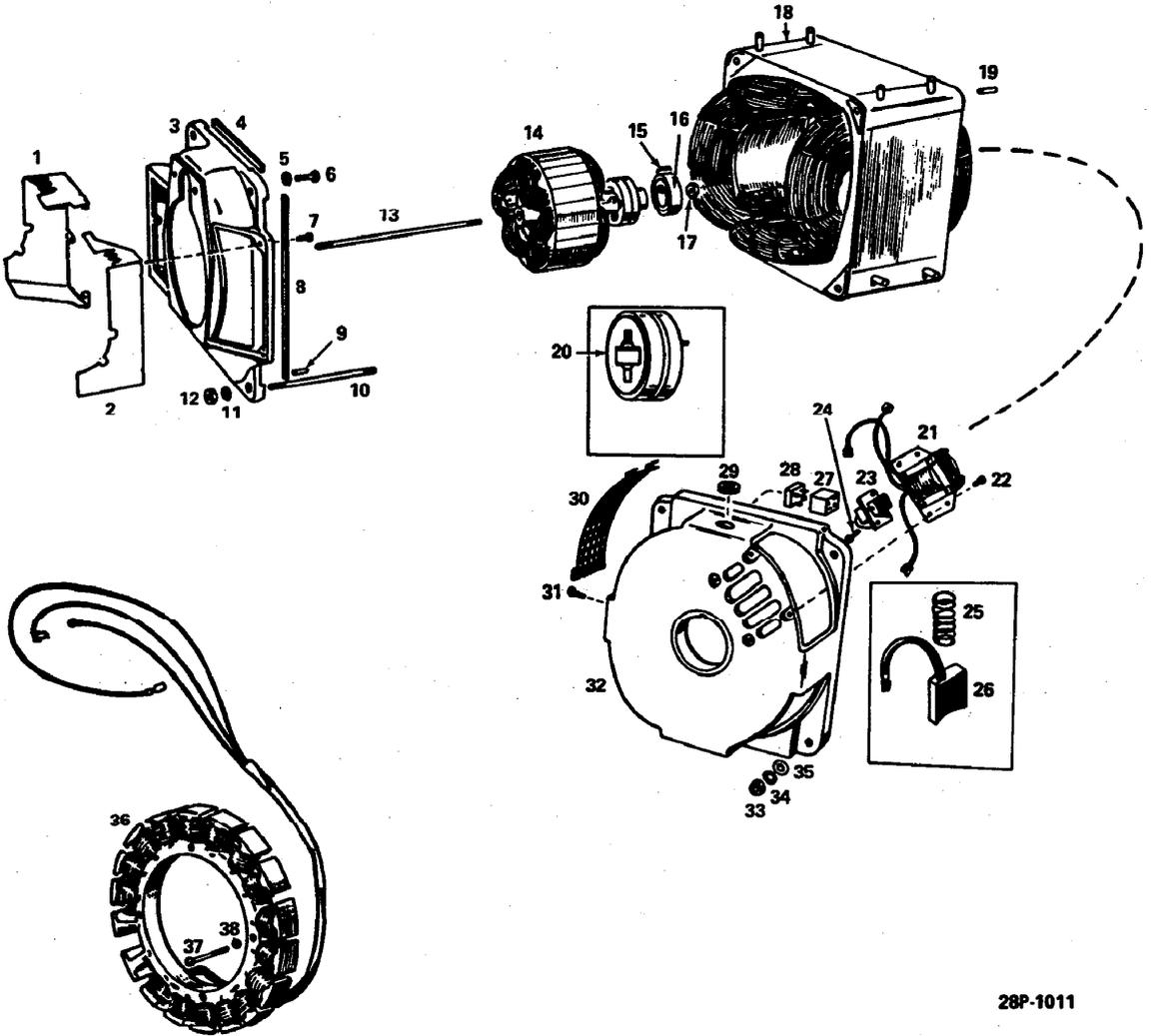

28P-1011

28.044 GENERATOR — ONAN 4KW

FURNISHINGS

KEY 230 260 PART NUMBER

28.044 GENERATOR—ONAN 4KW

706128 GENERATOR ASSY.—Onan 4KW (complete)

NOTE: Items marked * procure from Onan Corp.

NOTE: The above Generator Assembly No. 706128 includes the following items in groups 28.044 thru 28.044K and the Solenoid Valve Assembly No. 797242 in group 28.042.

—	—	1	706128	GENERATOR ASSY.—Onan 4KW (complete)
				NOTE: Items marked * procure from Onan Corp.
				NOTE: The above Generator Assembly No. 706128 includes the following items in groups 28.044 thru 28.044K and the Solenoid Valve Assembly No. 797242 in group 28.042.
1	1	1	707154	DUCT—generator air, (LH)
2	1	1	707153	DUCT—generator air, (RH)
3	1	1	707155	ADAPTER—control
4	2	2	* NS	SEAL—generator to adapter (ref. 707156) (232A2368)
5	4	4	103321	WASHER—lock, adapter mounting (3/8)
6	AR	AR	9420462	SCREW—adapter mounting (3/8—16 x 1-1/4") (hex)
7	AR	AH	—	SCREW—air duct mounting (10—32 x 3/8) (procure locally)
8	2	2	707156	SEAL—generator to adapter
9	4	4	707157	PIN—roll, generator adapter
10	4	4	* NS	STUD—generator mounting(ref. 707158) (520A731)
11	AR	AR	103320	WASHER—lock, generator through stud (5/16")
12	AR	AR	707174	NUT—hex, generator through stud
13	1	1	—	STUD—rotor through (procure locally)
14	1	1	* NS	ARMATURE ASSY.—wound (incl. bearing and collector ring)(ref. 707101)(201D1986)
15	1	1	707161	CLIP—generator bearing stop
16	1	1	* NS	BEARING—ball(ref. 707160) (510P47)
17	1	1	* NS	NUT—rotor through stud(ref. 707162) (870 - 273)
18	1	1	* NS	FRAME AND STATOR—wound (ref. 707163) (220D1857)
19	4	4	* NS	PIN—roll (ref. 707157) (156 - 182)
20	1	1	* NS	RING—collector(ref. 707159) (204C115)
21	1	1	* NS	REACTOR—compounding (ref. 707171) (315C380)
22	4	4	—	SCREW—hex, reactor mounting (10—32 x 7/8") (procure locally)
23	2	2	707102	BLOCK ASSY.—(incl. brushes and spring)
24	4	4	—	SCREW—hex, brush block mounting (10—32 x 7/8) (procure locally)
25	4	4	* NS	SPRING—brush (ref. 707170) (212A1232)
26	4	4	* NS	BRUSH (ref. 707169) (214A96)
27	1	1	* NS	PLUG—rectifier bridge (ref. 707168) (305B519)
28	1	1	707164	BRIDGE—rectifier
29	1	1	707167	GROMMET—output lead
30	3	3	* NS	SCREEN—end bell (ref. 707166) (234B46)
31	1	1	—	SCREW—hex, rectifier mounting (8—32 x 1-1/4) (procure locally)
32	1	1	707165	BELL—end
33	AR	AR	707174	NUT—hex, generator, through stud
34	AR	AR	103320	WASHER—lock, generator through stud (5/16")
35	4	4	707173	WASHER—flat, generator thorough stud
36	1	1	707184	STATOR—charging alternator
37	3	3	707185	SCREW—stator mounting (10—32 x 1-1/2") (round head)
38	3	3	707186	WASHER—stator mounting (10) (lock)
—	1	1	707409	KIT—gasket, oil pump
—	1	1	* NS	KIT—gasket, carbon removal (ref. 707410) (168K123)
—	1	1	* NS	KIT—gasket, engine (ref. 707411) (168K126)
—	1	1	* NS	KIT—overhaul (ref. 707412) (522K268)
—	1	1	* NS	KIT—carburetor air pre—heater (ref. 2018249) (140 - 1361)
—	1	1	710573	HARNESS—wiring, alternator
—	1	1	715810	HARNESS—generator to utility box, (incl. receptacle)
—	1	1	714228	SWITCH—remote, on and off (interior, 8 prong) (see group 28.044C)
—	1	1	719649	SWITCH—remote, on and off (interior, 5 prong) (see group 28.044C)
—	1	1	717015	GUARD—mud
—	2	2	710770	SCREW—battery cable terminal
—	4	4	710771	NUT—battery cable terminal
—	2	2	710773	WASHER—battery cable terminal
—	1	1	710774	WASHER—battery cable terminal
—	1	1	* NS	GROMMET—battery cable thru pan (ref. 710624) (508A60)

FURNISHINGS

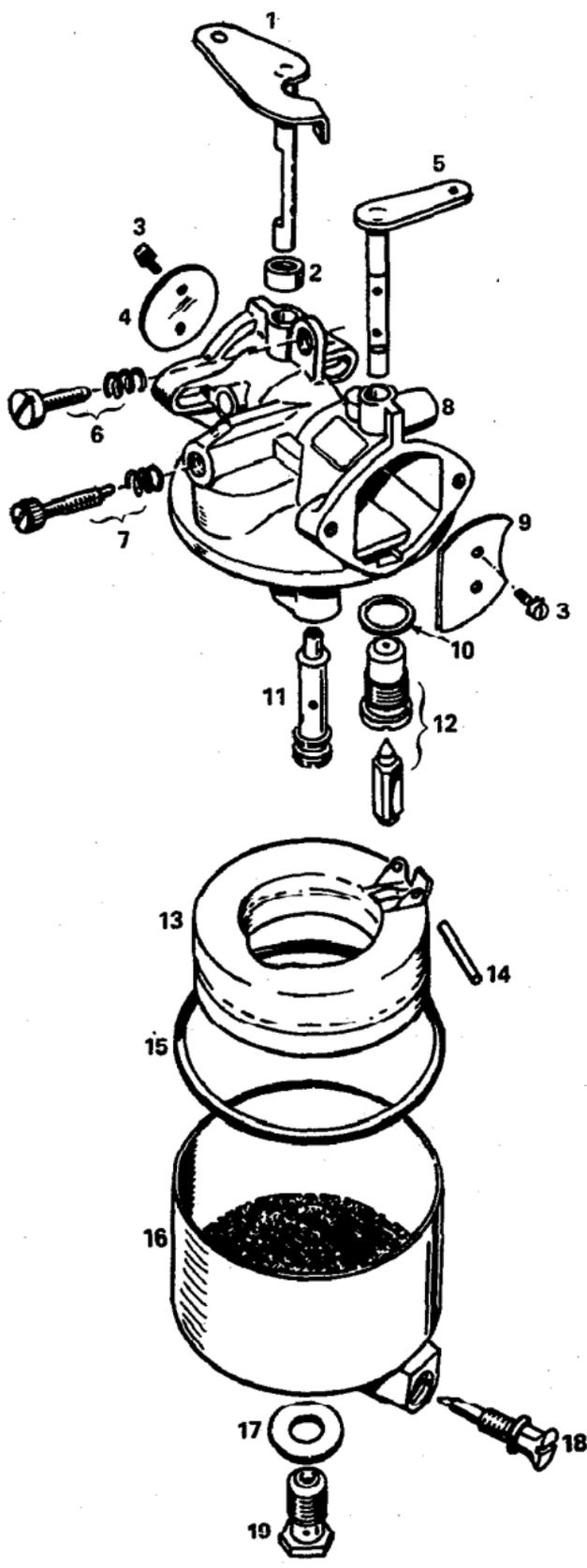

28P-1002

28.044A CARBURETOR - ONAN 4KW GENERATOR

FURNISHINGS

KEY 230 260 PART NUMBER

28.044A CARBURETOR—ONAN 4KW GENERATOR

—	1	1	707112	CARBURETOR ASSY.—complete
—	1	1	707407	KIT—gasket (incl. items marked *) (ref. only procure from ONAN CORP.)
—	1	1	707408	KIT—carburetor repair (incl. items marked *) (ref. only procure from ONAN CORP.)
1	1	1	* NS	SHAFT—throttle (ref. 707224) (146 - 172)
2	1	1	707225	SEAL—throttle shaft
3	4	4	707118	SCREW—throttle valve (incl. washer) (SOA)
4	1	1	* NS	VALVE—throttle (ref. 707226) (146 - 173)
5	1	1	* NS	SHAFT—choke (ref. 707223) (146 - 174)
6	1	1	707119	SPRING ASSY.—body adjusting (incl. screw) (SOA)
7	1	1	* NS	NEEDLE ASSY.—idler (incl. spring) (SOA) (ref. 707116) (146P116)
8	1	1	* NS	BODY—carburetor (ref. 707222) (146 - 170)
9	1	1	* NS	VALVE—choke (ref. 707227) (146 - 175)
10	1	1	* NS	GASKET—valve seat (ref. 707228) (146 - 182)
11	1	1	* NS	NOZZLE (ref. 707229) (146 - 181)
12	1	1	* NS	FLOAT—valve seat (ref. 707117) (146 - 179)
13	1	1	* NS	FLOAT—bowl (ref. 707114) (146 - 176)
14	1	1	* NS	SHAFT—bowl float (ref. 707230) (146 - P111)
15	1	1	* NS	GASKET—body to bowl (ref. 707231) (146 - 184)
16	1	1	707113	BOWL ASSY.—(incl. power needle and screw) (SOA)
17	2	2	* NS	GASKET—bowl nut (ref. 707232) (146 - 183)
18	1	1	* NS	NEEDLE—power carburetor bowl (ref. 707115) (146 - 187)
19	1	1	707234	RETAINER—bowl

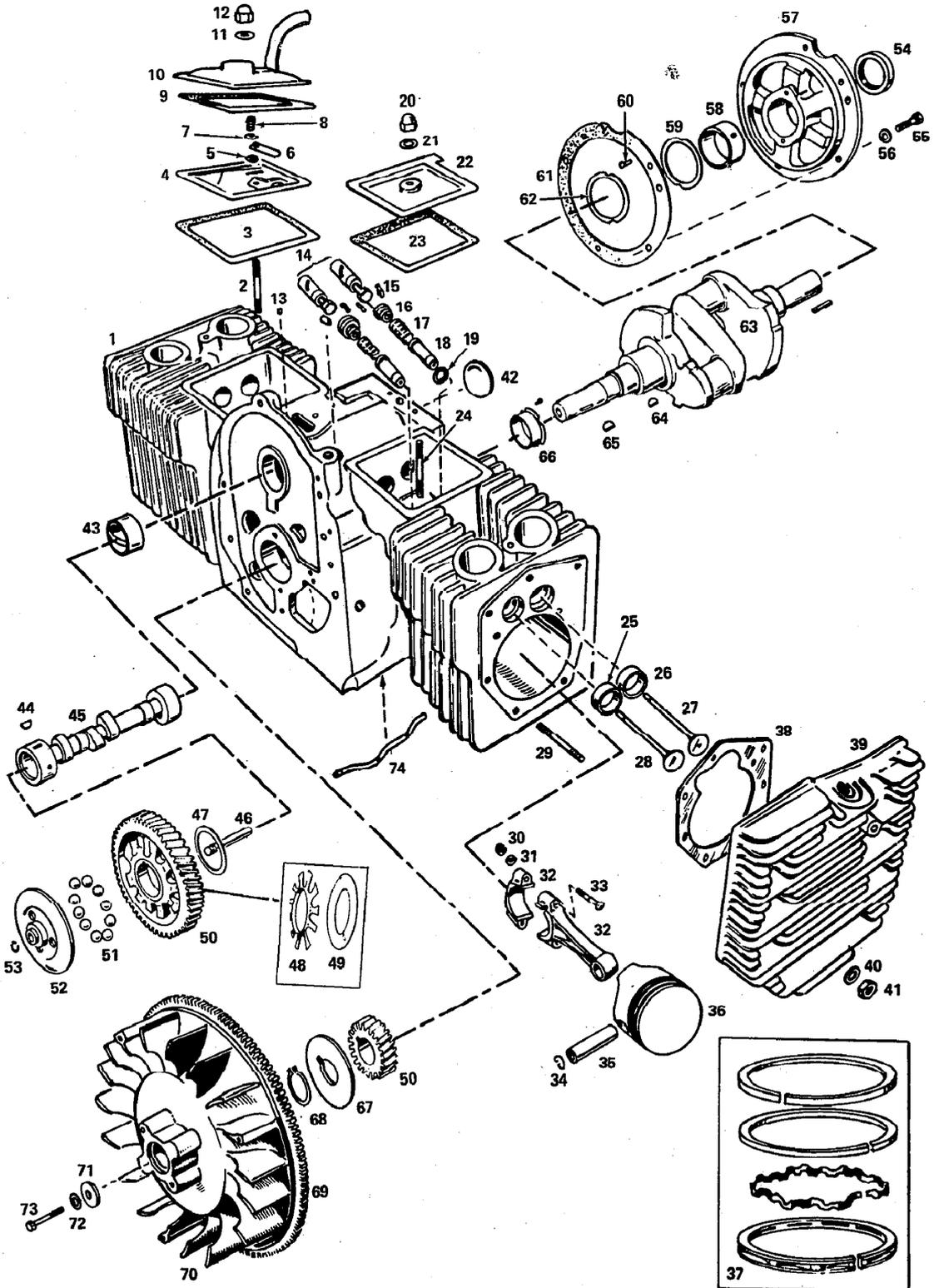

28.044B ONAN 4KW GENERATOR CYLINDER
BLOCK, CRANKSHAFT, FLYWHEEL, CAMSHAFT
AND PISTON

28P-1006

FURNISHINGS

KEY 230 260 PART NUMBER

28.044B ONAN 4KW GENERATOR—CYLINDER BLOCK CRANKSHAFT, FLYWHEEL, CAMSHAFT AND PISTON

NOTE: Items marked with asterisk are included in Block Assembly.

1	1	1	*	NS	BLOCK ASSY.— (ref. 707142) (110A1975)
2	12	12	*	NS	STUD—cylinder head (5/16 x 1—1/16") (ref. 707414) (520A759)
3	1	1		707364	GASKET—valve cover
4	1	1	*	NS	BAFFLE—breather (ref. 707366) (123C1225)
5	1	1		707416	WASHER—flat, breather valve (1/4 steel)
6	1	1	*	NS	VALVE—breather (ref. 707367) (123A1175)
7	1	1		707416	WASHER—flat, breather valve (1/4 steel)
8	1	1	*	NS	SPRING—breather valve (ref. 707368) (123A1174)
9	1	1	*	NS	GASKET—valve cover (ref. 707364) (110A1921)
10	1	1	*	NS	COVER—valve compartment with tube for breather hose, LH (110C1960)
11	1	1		9419892	WASHER—flat, valve compartment cover (1/4" copper)
12	1	1		124818	NUT—acorn, valve compartment cover (1/4—20)
13	1	1	*	707356	PLUG—impulse
14	4	4		707363	TAPPET—valve (.005" oversize)
15	8	8	*	NS	LOCK—valve and spring retainer (ref. 707361) (110A639)
16	4	4	*	NS	RETAINER—valve spring (ref. 707360) (110A893)
17	4	4	*	NS	SPRING—valve (ref. 707359) (110A539)
18	4	4	*	707358	GUIDE—valve
19	2	2	*	707357	GASKET—valve guide (intake)
20	1	1		—	NUT—acorn, valve compartment cover (1/4—20) (procure locally)
21	1	1		9419892	WASHER—flat, valve compartment cover (1/4" copper)
22	1	1	*	NS	COVER—valve compartment without tube for breather hose, RH (110C1879)
23	1	1	*	NS	GASKET—valve cover (ref. 707364) (110A68)
24	1	1	*	NS	STUD—valve compartment cover (1/4 x 2—1/16") (ref. 707415) (520A757)
25	2	2	*	707329	INSERT—valve seat exhaust (standard)
25	2	2	*	707330	INSERT—valve seat exhaust (.002" oversize)
25	2	2	*	707331	INSERT—valve seat exhaust (.005" oversize)
25	2	2	*	707305	INSERT—valve seat exhaust (.010" oversize)
25	2	2	*	707332	INSERT—valve seat exhaust (.025" oversize)
26	2	2	*	707333	INSERT—valve seat intake (standard)
26	2	2	*	707334	INSERT—valve seat intake (.002" oversize)
26	2	2	*	707335	INSERT—valve seat intake (.005" oversize)
26	2	2	*	707336	INSERT—valve seat intake (.010" oversize)
26	2	2	*	707337	INSERT—valve seat intake (.025" oversize)
27	2	2	*	NS	VALVE—intake (ref. 707327) (110B1808)
28	2	2	*	NS	VALVE—exhaust (ref. 707328) (110B1809)
29	6	6	*	NS	STUD—cylinder head (5/16 x 2—5/16") (ref. 707413) (520A424)
30	4	4		707323	NUT—hex, connecting rod cap
31	4	4		707322	WASHER—flat, connecting rod bolt
32	2	2	*	NS	ROD ASSY.—connecting (standard) (ref. 707130) (114B225)
32	2	2		707131	ROD ASSY.—connecting (.010" undersize)
32	2	2		707132	ROD ASSY.—connecting (.020" undersize)
32	2	2		707133	ROD ASSY.—connecting (.030" undersize)
33	4	4		707321	SCREW—connecting rod (special)
34	4	4		707320	RING—piston pin retaining
35	2	2		707318	PIN—piston (standard)
35	2	2		707319	PIN—piston (.002" oversize)
36	2	2	*	NS	PISTON—(incl. pin and retaining ring) (standard) (First Design) (112 - 123)
36	2	2		721448	PISTON—(incl. pin and retaining ring) (standard) (Second Design)
36	2	2	*	NS	PISTON—(incl. pin and retaining ring) (.005" oversize) (repl. 707135) (112 - 134 - 05)
36	2	2	*	NS	PISTON—(incl. pin and retaining ring) (.010" oversize) (repl. 707136) (112 - 134 - 010)
36	2	2	*	NS	PISTON—(incl. pin and retaining ring) (.020" oversize) (repl. 707137) (112 - 134 - 020)
36	2	2	*	NS	PISTON—(incl. pin and retaining ring) (.030" oversize) (repl. 707138) (112 - 134 - 030)
36	2	2	*	NS	PISTON—(incl. pin and retaining ring) (.040" oversize) (repl. 707139) (112 - 134 - 040)
37	2	2		2014413	RING SET—piston (standard) (repl. 707312, 721454)
37	2	2		721455	RING SET—piston (.005" oversize) (repl. 707313)
37	2	2	*	NS	RING SET—piston (.010" oversize) (repl. 707314) (ref. 721456) (113A174 - 010)
37	2	2	*	NS	RING SET—piston (.020" oversize) (repl. 707315) (ref. 721457) (113A)
37	2	2	*	NS	RING SET—piston (.030" oversize) (repl. 707316) (ref. 721459) (113A174 - 030)
37	2	2	*	NS	RING SET—piston (.040" oversize) (repl. 707317) (ref. 721460) (113A174 - 040)
—	2	2		2014414	EXPANDER—piston ring
38	2	2		707326	GASKET—cylinder head
39	1	1	*	NS	HEAD—cylinder (2 cylinder) (RH) (ref. 707324) (110D1924)

FURNISHINGS

KEY 230 260 PART NUMBER

28.044B ONAN 4KW GENERATOR—CYLINDER BLOCK CRANKSHAFT, FLYWHEEL, (Cont.)

39	1	1	*	NS	HEAD—cylinder (1 cylinder) (LH) (ref. 707325) (110D1925)
40	18	18		9418304	WASHER—flat cylinder head stud (5/16" steel)
41	18	18		9421077	NUT—hex, cylinder head (5/16—24)
42	1	1	*	707345	PLUG—camshaft, expansion
43	2	2	*	NS	BEARING—camshaft (precision) (ref. 707344) (101A367)
44	1	1	*	NS	KEY—camshaft gear mounting (ref. 707297) (515 - 1)
45	1	1	*	NS	CAMSHAFT—(incl. center pin) (ref. 707140) (105A376)
46	1	1	*	NS	PIN—camshaft center (ref. 707298) (150A75)
47	1	1	*	NS	WASHER—camshaft gear thrust (ref. 707299) (105A4)
48	1	1		711492	PLATE—governor ball
49	1	1		711493	SPACER—governor ball
50	1	1		707300	GEAR SET—timing (incl. camshaft and crankshaft gear)
51	10	10		707301	BALL—fly, governor
52	1	1	*	NS	CUP—governor (ref. 707302) (150B162)
53	1	1	*	NS	RING—camshaft center pin (re. 707303) (150A78)
54	1	1	*	707355	SEAL—bearing plate
55	5	5		9420462	SCREW—hex cap, bearing plate mounting (3/8—16 x 1-1/4")
56	5	5	*	103321	WASHER—lock, rear bearing plate (3/8")
57	1	1	*	707354	PLATE—rear bearing (excludes bearing)
58	1	1	*	707346	BEARING—crankshaft rear (standard)
58	1	1	*	707347	BEARING—crankshaft rear (.002" undersize)
58	1	1	*	707348	BEARING—crankshaft rear (.010" undersize)
58	1	1	*	707349	BEARING—crankshaft rear (.020" undersize)
58	1	1	*	707350	BEARING—crankshaft rear (.030" undersize)
59	AR	AR	*	NS	SHIM—rear bearing plate (.005") (ref. 707352) (104A776)
60	4	4	*	707293	PIN—main bearing stud
61	1	1	*	707353	GASKET—bearing plate
62	2	2	*	707351	WASHER—crankshaft bearing thrust
63	1	1	*	NS	CRANKSHAFT (ref. 707304) (104D804)
64	1	1		707297	KEY—crankshaft gear mounting
65	1	1	*	NS	KEY—flywheel mounting (ref. 707306) (515 - 2)
66	1	1	*	NS	BEARING—crankshaft, front (standard) (ref. 707339) (101K432)
66	1	1	*	707340	BEARING—crankshaft, front (.002" undersize)
66	1	1	*	707341	BEARING—crankshaft, front (.010" undersize)
66	1	1	*	707342	BEARING—crankshaft, front (.020" undersize)
66	1	1	*	707343	BEARING—crankshaft, front (.030" undersize)
67	1	1	*	NS	WASHER—crankshaft gear retaining (ref. 707307) (104A43)
68	1	1		707308	LOCK—crankshaft gear washer
69	1	1	*	NS	GEAR—ring, flywheel (ref. 707309) (104C779)
70	1	1		707141	FLYWHEEL—(incl. ring gear and magnet ring)
71	1	1		707310	WASHER—flat, flywheel mounting
72	1	1		707311	WASHER—lock, flywheel mounting
73	1	1		—	SCREW—hex, flywheel mounting (7/16—14 x 4) (procure locally)
74	1	1	*	707338	TUBE—crankcase oil

FURNISHINGS

NOTES

FURNISHINGS

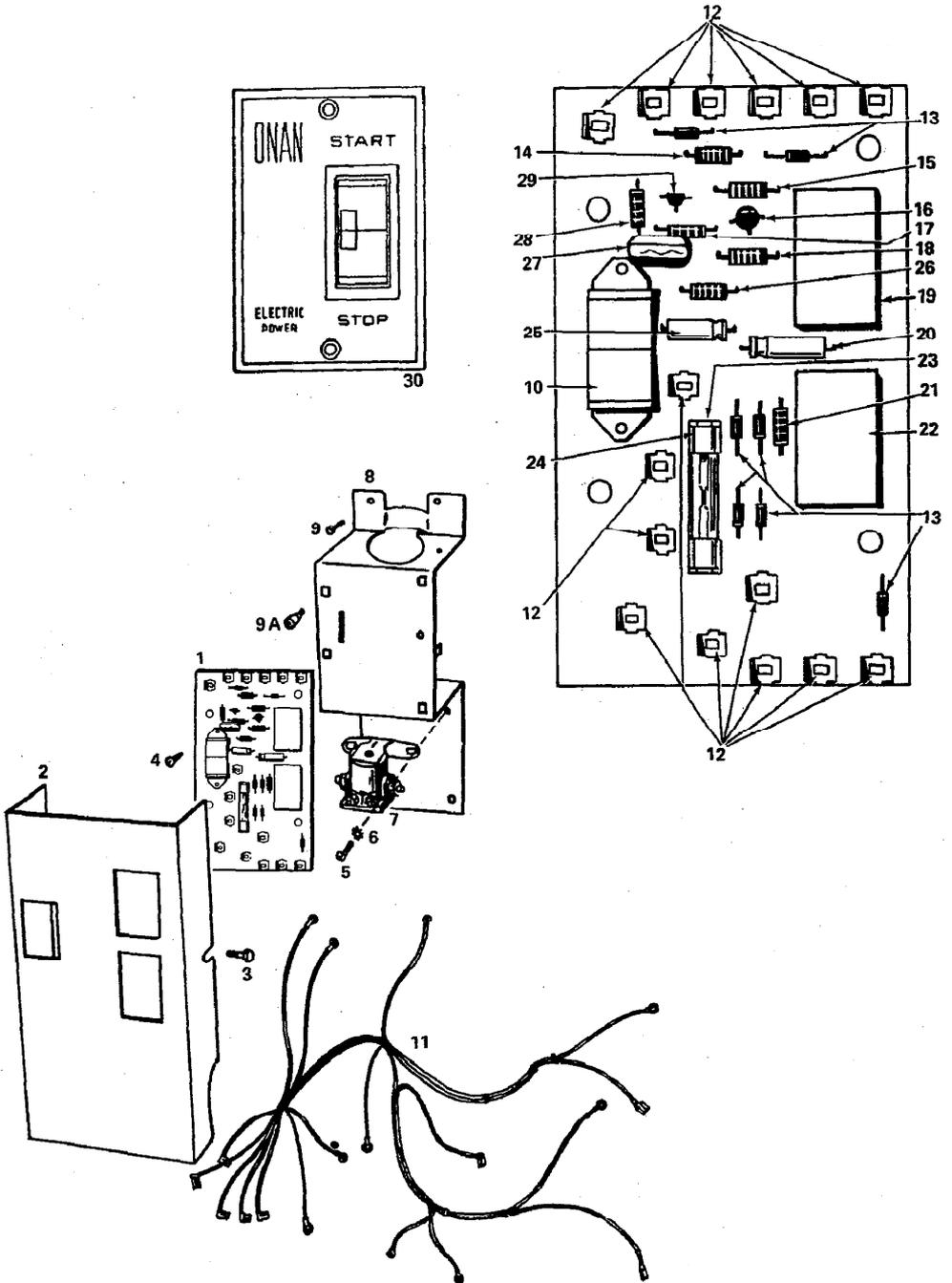

28.044C CONTROL - ONAN 4KW GENERATOR

FURNISHINGS

KEY 230 260 PART NUMBER

28.044C CONTROL—ONAN 4KW GENERATOR

1	1	1	793986	CONTROL ASSY.—generator (incl. next 19 items) (repl. 707144)
—	1	—	711483	CAPACITOR—control (100 MFD. 15 VDC)
—	4	—	707374	RECTIFIER—control silicon
—	1	—	793988	RELAY—control start disconnect
—	1	—	793989	RELAY—control engine stop
—	1	—	707377	RESISTOR—control 100—OHM 1/2 watt
—	1	—	707378	RESISTOR—control 330 OHM 1/2 watt
—	1	—	NS	SWITCH—control (ref. 707379) (308A320)
—	15	—	707380	TAB—control stake
—	1	—	710759	CAPACITOR—(5MFD., 25 volt)
—	1	—	710760	CAPACITOR—(1 MFD., 100 volt)
—	1	—	2000363	RECTIFIER—gate cont (8 amp., 30 volt)
—	1	—	710762	FUSE—(5 amp.)
—	2	—	710763	CLIP—fuse holder
—	1	—	710764	TRANSISTOR—Uni Junction
—	1	—	710765	RESISTOR—(200 OHM, 1/2 watt)
—	1	—	710766	RESISTOR—(470K OHM, 1/2 watt)
—	1	—	710767	RESISTOR—(27K OHM, 1/2 watt)
—	1	—	710768	RESISTOR—(16K OHM, 1/2 watt)
—	1	—	710769	RESISTOR—(2.7 OHM, 1/2 watt)
2	1	1	NS	COVER—control (ref. 707381) (301B3597)
3	2	2	707382	SCREW—control cover mounting (10 x 1/2") (hex)
4	4	4	—	SCREW—sheet metal, control to bracket (8 x 1") (procure locally)
5	2	2	—	SCREW—round head, start solenoid mounting (1/4—20 x 3/8") (procure locally)
6	2	2	707371	WASHER—start solenoid mounting shake proof
7	1	1	707143	RELAY—start solenoid
8	1	1	707370	BRACKET—control and coil, mounting
9	4	4	—	SCREW—control bracket mounting (10—32 x 5/16") (hex) (procure locally)
9A	4	4	707372	NUT—insulating control to bracket
10	1	1	707379	SWITCH
11	1	1	707145	HARNES—wiring, control to engine
12	15	15	707380	TAB—stake
13	7	7	707374	RECTIFIER—silicon
14	1	1	707378	RESISTOR—(330—OHM-1/2 watt)
15	1	1	NPN	RESISTOR—(470—OHM-1/2 watt)
16	1	1	NPN	TRANSISTOR—unijunction
17	1	1	707377	RESISTOR—(100—OHM-1/2 watt)
18	1	1	NPN	RESISTOR—(16K—OHM-1/2 watt)
19	1	1	793988	RELAY—start disconnect (repl. 707375)
20	1	1	711483	CAPACITOR—(100 med. 16V—DC) (repl. 711483)
21	1	1	NPN	RESISTOR—(200—OHM-1/2 watt)
22	1	1	793989	RELAY—engine stop (repl. 707376)
23	1	1	NPN	FUSE—5 amp.
24	2	2	NPN	CLIP—fuse holder
25	1	1	NPN	CAPACITOR—(5 med., 25 volt)
26	1	1	NPN	RESISTOR—(27K—OHM-1/2 watt)
27	1	1	NPN	CAPACITOR—(.1 med., 100 volt)
28	1	1	NPN	RESISTOR—(2.7—OHM-1/2 watt)
29	1	1	NPN	RECTIFIER—gate control (8 amp., 30 volt)
30	1	1	719649	SWITCH—remote, on and off (interior) (repl. 714228)
—	1	1	711484	LABEL—control

FURNISHINGS

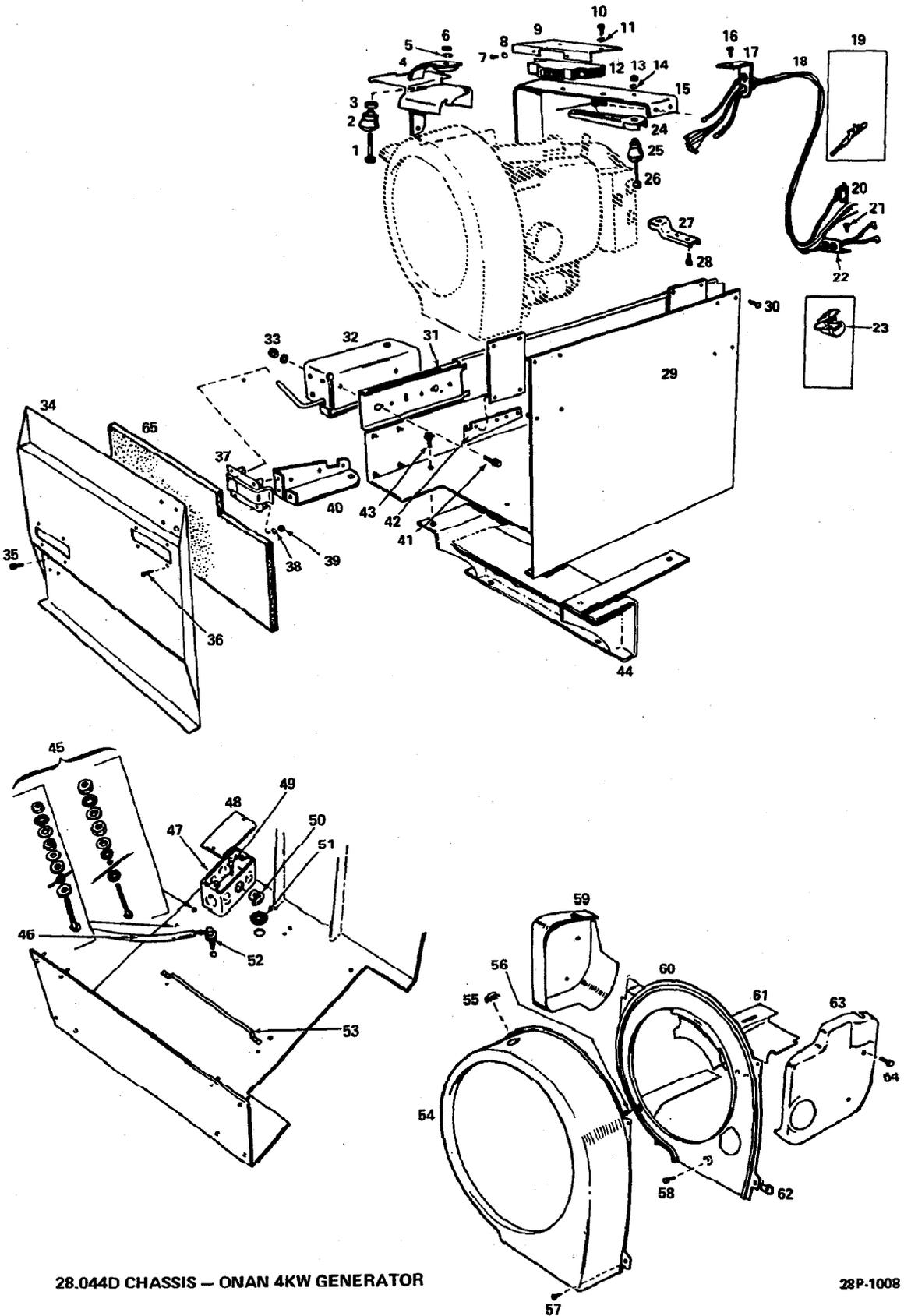

28.044D CHASSIS — ONAN 4KW GENERATOR

28P-1008

FURNISHINGS

KEY 230 260 PART NUMBER

28.044D CHASSIS—ONAN 4KW GENERATOR

1	2	2	*	NS	BOLT—cushion mounting (ref. 707395) (402A412)
2	2	2		707394	CUSHION—mount
3	1	1	*	NS	SPACER—cushion mounting (ref. 707396) (402A413)
4	1	1	*	NS	FOOT ASSY.—engine mounting RH (SOA) (ref. 707149) (403A1019)
5	2	2		103321	WASHER—lock, generator support mounting (3/8")
6	4	4		707417	NUT—self locking cushion mount
7	2	2		—	SCREW—round head circuit breaker mounting (6—32 x 1/4) (procure locally)
8	1	1		—	WASHER—lock, circuit breaker mounting (6) (procure locally)
9	1	1		707398	BRACKET—circuit breaker mounting
10	2	2		—	SCREW—self locking, circuit breaker bracket mounting (1/4—20 x 3/8")
11	1	1		—	WASHER—lock, circuit breaker mounting (6) (procure locally)
12	1	1		707397	BREAKER—circuit
13	2	2		707417	NUT—self locking mounting
14	2	2		103321	WASHER—lock, generator support mounting (3/8)
15	1	1		707391	YOKE—generator support
16	AR	AR		—	SCREW—self locking, wiring harness bracket mounting (1/4—20 x 3/8) (hex head) (procure locally)
17	1	1		707390	BRACKET—harness mounting (part of wiring harness)
18	1	1	*	NS	HARNES—wiring, chassis (ref. 707147) (338D702)
19	6	6		707389	CONTACT—connection (part of wiring harness)
20	1	1		707388	BODY—connection (part of wiring harness)
21	AR	AR		—	SCREW—wiring harness, bracket mounting (1/4—20 x 3/8") (self locking hex) (procure locally)
22	1	1		707387	BRACKET—harness (part of wiring harness)
23	4	4		707386	RELIEF—strain (part of wiring harness)
24	1	1	*	NS	SUPPORT—generator (RH) (ref. 707393) (232C2364)
25	2	2	*	NS	CUSHION—mount (ref. 707394) (402B283)
26	2	2		707395	BOLT—cushion mount
27	1	1		707392	SUPPORT—generator (LH)
28	AR	AR		9420462	SCREW—generator support (3/8—16 x 1-1/4) (hex cap)
29	1	1		707399	PAN—mounting base
30	16	16		707418	SCREW—press, slide rail mounting (1/4—20 x 3/4) (hex head)
31	2	2		707152	SLIDE ASSY.
32	1	1	*	NS	BRACKET AND CATCH ASSY.—safety (SOA) (ref. 707146) (405B1950)
33	AR	AR		9422273	NUT—self locking, slide rail mounting (1/4—20)
34	1	1		707151	DOOR—slide out (SOA)
35	AR	AR		—	SCREW—self locking, door latch mounting (1/4—20 x 3/8) (procure locally)
36	AR	AR		—	SCREW—self locking, slide rail (1/4—20 x 3/8) (procure locally)
37	2	2		711485	LATCH—door (SOA) (repl. 707150)
38	1	1		—	WASHER—lock, circuit breaker (6) (procure locally)
39	AR	AR		9422273	NUT—self locking, door latch mounting (1/4—20)
40	1	1	*	NS	BRACKET—engine end (LH) (ref. 707264) (405C1958)
41	AR	AR		—	SCREW—self locking slide rail (1/4—20 x 3/8) (procure locally)
42	2	2		707400	BRACKET—latch strike
43	AR	AR		9427321	SCREW—set, mounting bracket to base pan (3/8 x 1—1/4) hex cap, self locking (300M)
44	1	1		707401	BRACKET—set mounting
45	1	1		—	KIT—bolt and nut (procure locally)
46	1	1	*	NS	HOSE—fuel (ref. 707406) (503A673)
47	1	1		707402	BOX—junction
48	1	1		707403	COVER—junction-box
49	3	3		—	SCREW—self locking, junction box mounting (1/4—20 x 3/8") (procure locally)
50	1	1		707404	BUSHING—junction box
51	1	1		710624	GROMMET—battery cable, pan
52	1	1		707405	CONNECTOR—elbow fuel line
53	1	1		710606	BRACKET—fuel line return
54	1	1		707187	COVER—blower housing, scroll
55	1	1		710572	PLUG—scroll cover, dot button
56	4	4		707188	SCREW—scroll mounting (sheet metal)
57	4	4		707188	SCREW—scroll cover mounting (sheet metal)
58	4	4		—	SCREW—air cylinder housing mounting (1/4—20 x 7/16) (hex head) (procure locally)
59	1	1	*	NS	HOUSING—air cylinder, LH (ref. 707193) (134D2565)
60	1	1	*	NS	SCROLL—blower housing (ref. 707190) (134C2570)

FURNISHINGS

KEY 230 260 PART NUMBER

28.044D CHASSIS—ONAN 4KW GENERATOR (Cont.)

61	1	1	*	NS	BAFFLE—air cylinder, RH (ref. 707192) (134C2567)
62	8	8		707189	CLIP speed nut, scroll cover mounting
63	1	1	*	NS	HOUSING—air cylinder, RH (ref. 707191) (134C2564)
64	2	2		707263	SCREW—scroll mounting (1/4—20 x 7/16) (hex)
65	1	1		710623	INSULATION—slide out door

FURNISHINGS

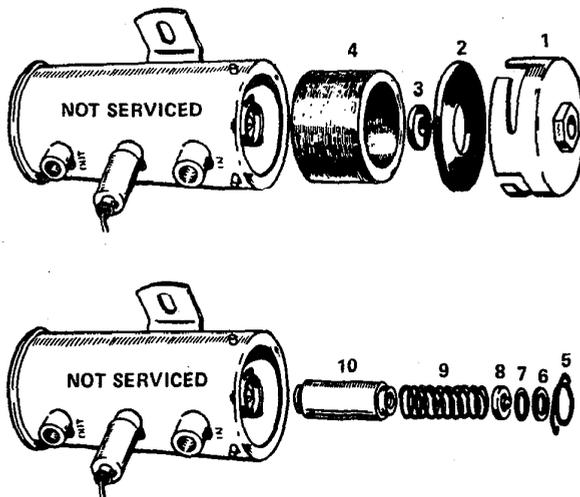

28P-1001

KEY	230	260	PART NUMBER
-----	-----	-----	-------------

28.044E PUMP—FUEL, ONAN GENERATOR

—	1	1	707120	PUMP—fuel assy. (incl. items thru asterisk)
1	1	1	707265	COVER
2	1	1	* NS	GASKET—cover (ref. 707266) (149 - 1446)
3	1	1	707251	MAGNET
4	1	1	707267	FILTER
5	1	1	707268	RETAINER—cup and plunger
6	1	1	707269	WASHER—cup gasket
7	1	1	707270	GASKET—spring cup
8	1	1	* NS	SPRING—cup and valve (SOA) (ref. 707122) (149 - 1451)
9	1	1	707271	SPRING—plunger return
10	1	1	* 707272	PLUNGER

FURNISHINGS

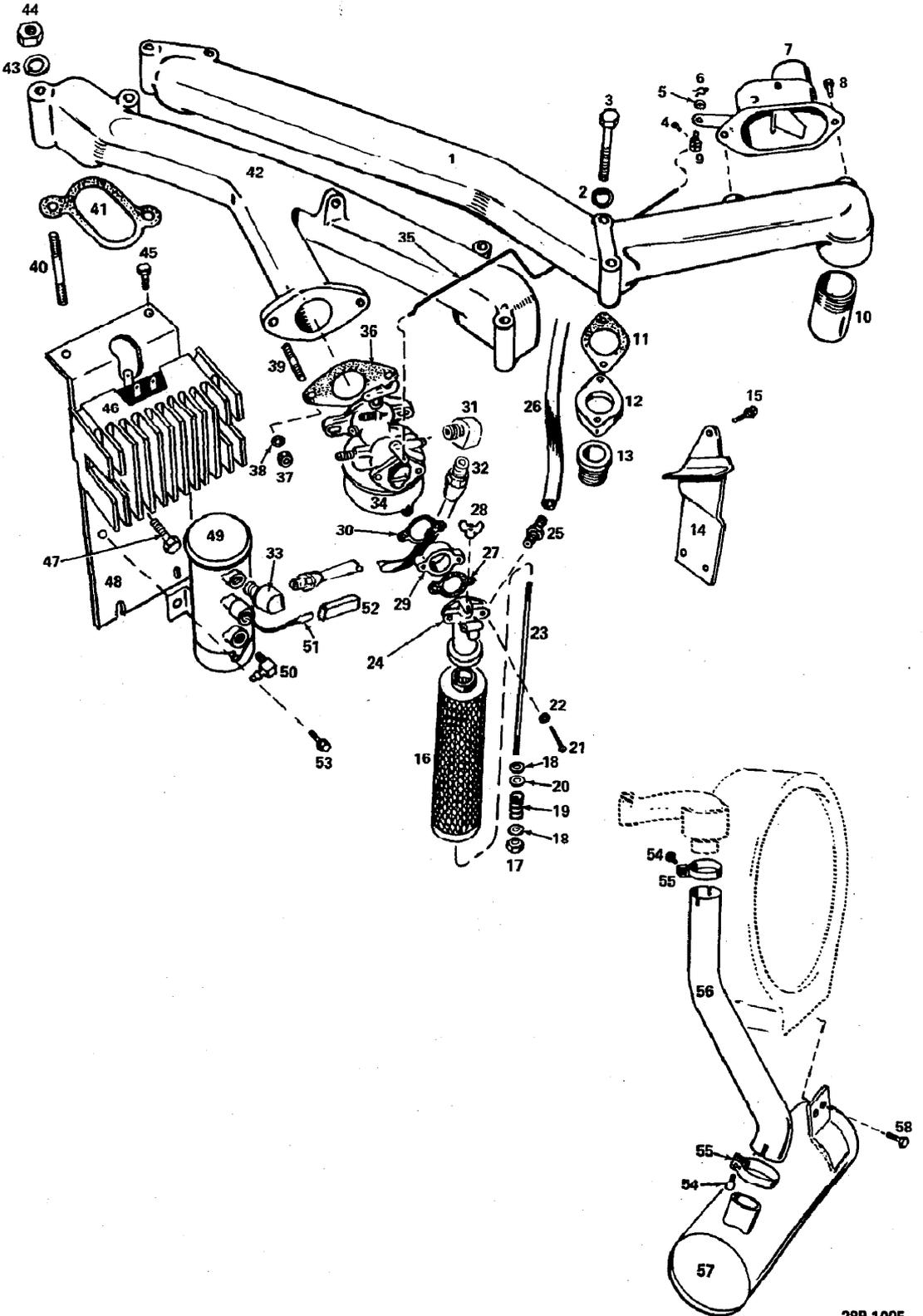

28.044F ONAN 4 KW GENERATOR FUEL SYSTEM

28P-1005

FURNISHINGS

KEY 230 260 PART NUMBER

28.044F ONAN 4KW GENERATOR—FUEL SYSTEM

1	1	1	*	NS	MANIFOLD—exhaust (ref. 707235) (154D1518)
2	4	4	—	—	WASHER—flat. exhaust manifold and mounting (5/16) (procure locally)
3	4	4	—	—	SCREW—hex. exhaust manifold mounting (5/16—18 x 1-3/4") (procure locally)
4	4	4	—	—	SCREW—hex. fuel pump and regulator bracket mounting (1/4—20 x 5/16") (procure locally) (ref. 707263)
5	1	1	—	—	WASHER—flat. choke swivel (procure locally) (ref. 707243)
6	1	1	—	—	PIN—cotter. choke swivel (procure locally) (ref. 707244)
7	1	1		707241	CHOKE—sisson
8	2	2	—	—	SCREW—self locking. choke mounting (1/4—20 x 3/8") (procure locally)
9	1	1	*	NS	SWIVEL—choke. linkage (ref. 707242) (152A155)
10	1	1	*	NS	NIPPLE—exhaust. manifold outlet (ref. 707240) (505 - 755)
11	2	2	*	NS	GASKET—exhaust. manifold (ref. 707236) (154A1526)
12	2	2	*	NS	FLANGE—exhaust. manifold mounting (ref. 707237) (154A1537)
13	2	2	*	NS	NIPPLE—exhaust (ref. 707238) (154A1536)
14	1	1	*	NS	BRACKET—muffler (ref. 707239) (155B1237)
15	3	3	—	—	SCREW—muffler bracket (procure locally)
16	1	1		707256	ELEMENT—air cleaner
17	1	1	—	—	NUT—square. air cleaner mounting (No. 10—32) (procure locally)
18	2	2		707258	WASHER—flat. air cleaner mounting
19	1	1		711489	SPRING—air cleaner element mounting
20	1	1		711488	WASHER—fibre. air cleaner element mounting
21	2	2	—	—	SCREW—round head. air cleaner adapter mounting (No. 8—32 x 1-1/2") (procure locally)
22	2	2	—	—	WASHER—lock. air cleaner adapter mounting (No. 8) (procure locally)
23	1	1		711486	STUD—air cleaner mounting
24	1	1	*	707121	ADAPTER—air cleaner (incl. breather hose adapter)
25	1	1	*	NS	ADAPTER—breather hose (ref. 707254) (502 - 193)
26	1	1		707255	HOSE—breather
27	1	1		707252	GASKET—air cleaner adapter
28	1	1		707259	NUT—wing. air cleaner
29	1	1	*	NS	SPACER—carburetor to air cleaner adapter (ref. 707253) (146P163)
30	1	1	*	NS	GASKET—air cleaner adapter (ref. 710383) (145A446)
31	1	1		710380	ELBOW—carburetor. inlet
32	1	1		NS	HOSE—fuel
33	1	1		NS	ELBOW—fuel pump inlet
34	1	1		707112	CARBURETOR
35	1	1	*	NS	LINKAGE—choke (ref. 707250) (153A451)
36	1	1		707248	GASKET—carburetor mounting
37	2	2	—	—	NUT—hex. carburetor mounting (1/4—28) (procure locally)
38	2	2	—	—	WASHER—lock. carburetor mounting (1/4") (procure locally)
39	2	2		707249	STUD—carburetor mounting
40	4	4		707247	STUD—intake. manifold mounting
41	2	2		707246	GASKET—intake. manifold
42	1	1		707245	MANIFOLD—intake
43	4	4	—	—	WASHER—lock. intake manifold mounting (5/16") (procure locally)
44	4	4		707174	NUT—hex. intake manifold mounting (5/16—18)
45	4	4		707263	SCREW—hex. fuel pump and regulator-bracket mounting (No. 10—32 x 5/16")
46	1	1		707182	REGULATOR—12 volt
47	2	2		707183	SCREW—regulator. mounting (1/4—20 x 5/8) self locking
48	1	1	*	NS	BRACKET—fuel pump and regulator mounting (ref. 707262) (149C1316)
49	1	1		707120	PUMP—fuel
50	1	1		707261	ELBOW—fuel pump
51	1	1		711490	TERMINAL—fuel pump lead
52	1	1		711491	CONNECTOR—fuel pump lead
53	2	2	—	—	SCREW—self locking. fuel pump mounting (1/4—20 x 3/8") (procure locally)
54	2	2		707385	BOLT—carriage muffler
55	2	2		707384	CLAMP—exhaust
56	1	1		707383	TUBE—exhaust
57	1	1		707148	MUFFLER—exhaust
58	2	2	—	—	SCREW—muffler mounting (1/4—20 x 3/8) (procure locally)
—	1	1		797242	VALVE—fuel solenoid

FURNISHINGS

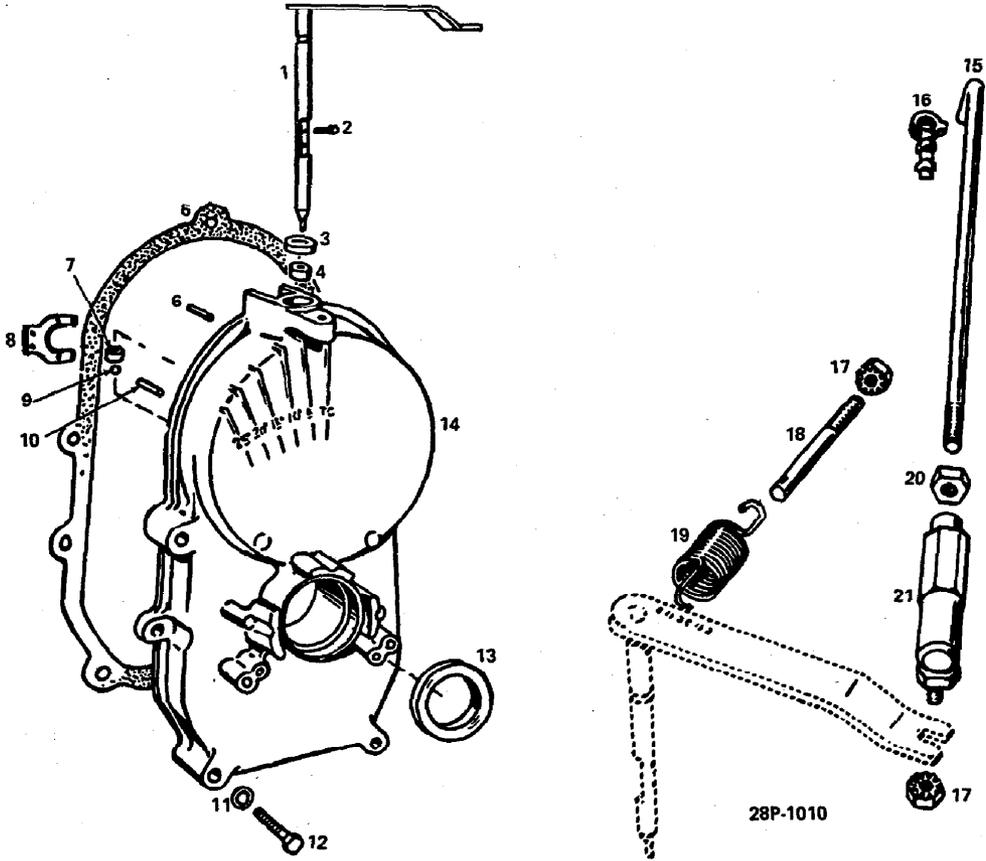

KEY 230 260 PART NUMBER

28.044G GEAR COVER—ONAN 4KW GENERATOR

NOTE: Items with asterisk are part of Cover Assembly

1	1	1	*	NS	SHAFT AND ARM ASSY.—governor (SOA) (ref. 707124) (150A1375)
2	2	2	*	707276	SCREW—yoke retaining
3	1	1	*	NS	SEAL—oil, governor shaft (509P8)
4	1	1	*	NS	BEARING—governor shaft (upper) (ref. 707273) (510P13)
5	1	1		707277	GASKET—gear cover mounting
6	2	2		—	PIN—gear cover (5/16 x 1-1/8") (procure locally)
7	1	1	*	707281	BEARING—governor shaft (lower)
8	1	1	*	NS	YOKE—governor shaft (upper) (ref. 707275) (150A1187)
9	1	1	*	707280	BALL—bearing, governor shaft
10	1	1	*	NS	PIN—governor cup, stop (ref. 707278) (518 - 4)
11	5	5		103320	WASHER—lock, gear cover mounting (5/16)
12	4	4		—	SCREW—gear cover mounting (5/16—18 x 1-3/4) (procure locally)
13	2	2	*	707279	SEAL—gear cover
14	1	1	*	NS	COVER ASSY.—gear (ref. 707123) (103C417)
15	1	1	*	NS	ROD—governor control (ref. 707175) (150B1377)
16	1	1		707176	CLIP—governor control rod
17	1	1		707181	NUT—keeps, governor ball joint and adjusting stud
18	1	1		710079	STUD—adjusting, governor
19	1	1	*	NS	SPRING—governor (ref. 707178) (150A98)
20	1	1	*	NS	PALNUT—governor rod (ref. 707180) (870 - 188)
21	1	1		707179	JOINT—ball, governor
—	1	1	—	—	SCREW—gear cover mounting (5/16—18 x 2-1/4) (procure locally)

FURNISHINGS

NOTES

FURNISHINGS

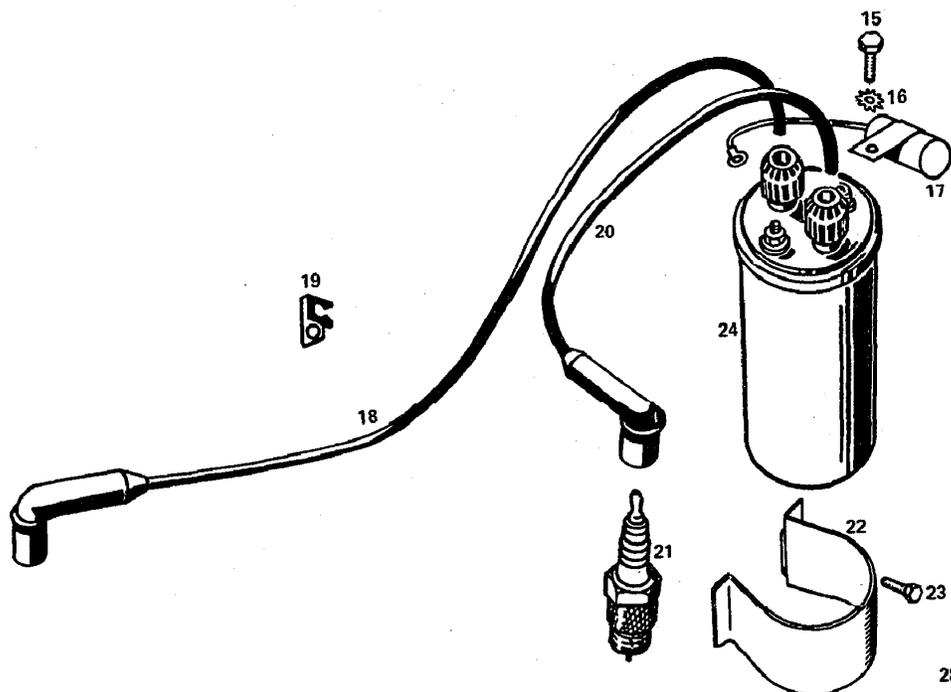
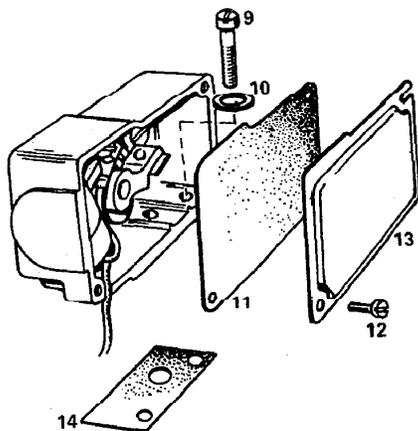
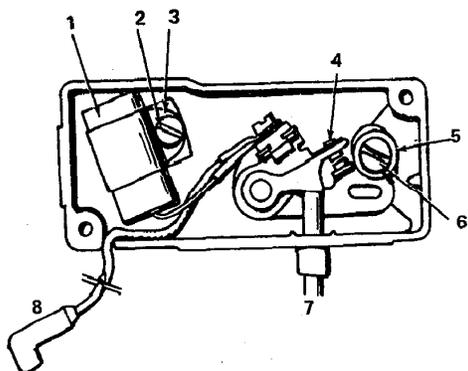

28P-1009

28.044H IGNITION – ONAN 4KW GENERATOR

FURNISHINGS

KEY 230 260 PART NUMBER

28.044H IGNITION—ONAN 4KW GENERATOR

NOTE: Items with asterisk are part of Box Assembly.

—	1	1		707110	BOX ASSY.—
1	1	1	*	707217	CONDENSER—breaker points
2	1	1	*	—	SCREW—breaker points and condenser mounting (8—32 x 3/8") (slotted pan head) (procure locally)
3	1	1	*	—	WASHER—breaker points and condenser mounting (No. 8) (lock) (procure locally)
4	1	1	*	707218	POINT SET—breaker
5	1	1	*	—	WASHER—point set, mounting (No. 8) (flat) (ref. 131015) (procure locally)
6	1	1	*	—	SCREW—breaker points and condenser mounting (No. 8—32 x 3/8") (slotted pan head) (procure locally)
7	1	1	*	NS	PLUNGER (ref. 707219) (160A115)
8	1	1	*	707111	LEAD ASSY.—(SOA)
9	2	2		9419000	SCREW—breaker box mounting (1/4—20 x 1/2") (fillister phillips head)
10	2	2		103319	WASHER—lock, breaker box mounting (1/4")
11	1	1	*	707220	GASKET—breaker box, cover
12	2	2	*	—	SCREW—breaker box cover mounting (8—32 x 3/8") (procure locally)
13	1	1	*	707221	COVER—breaker box
14	1	1		707216	GASKET—breaker box mounting
15	1	1		707382	SCREW—condenser mounting (No. 10—32 x 1/2") (hex)
16	1	1		707211	WASHER—condenser mounting (No. 8) (shake proof)
17	1	1	*	NS	CONDENSER—ignition (ref. 707210) (312A17)
18	1	1		710365	CABLE—spark plug (21")
19	1	1		707214	CLIP—spark plug cable
20	1	1		710364	CABLE—spark plug (8—1/2")
21	1	2		5612073	PLUGS spark (repl. 707215)
22	1	1	*	NS	CLAMP—coil mounting (ref. 707208) (166B603)
23	1	1		707209	SCREW—coil clamp mounting (No. 10—32 x 3/8")
24	1	1		2021066	COIL—ignition (repl. 707207)
—	1	1		710363	CAP—ignition

FURNISHINGS

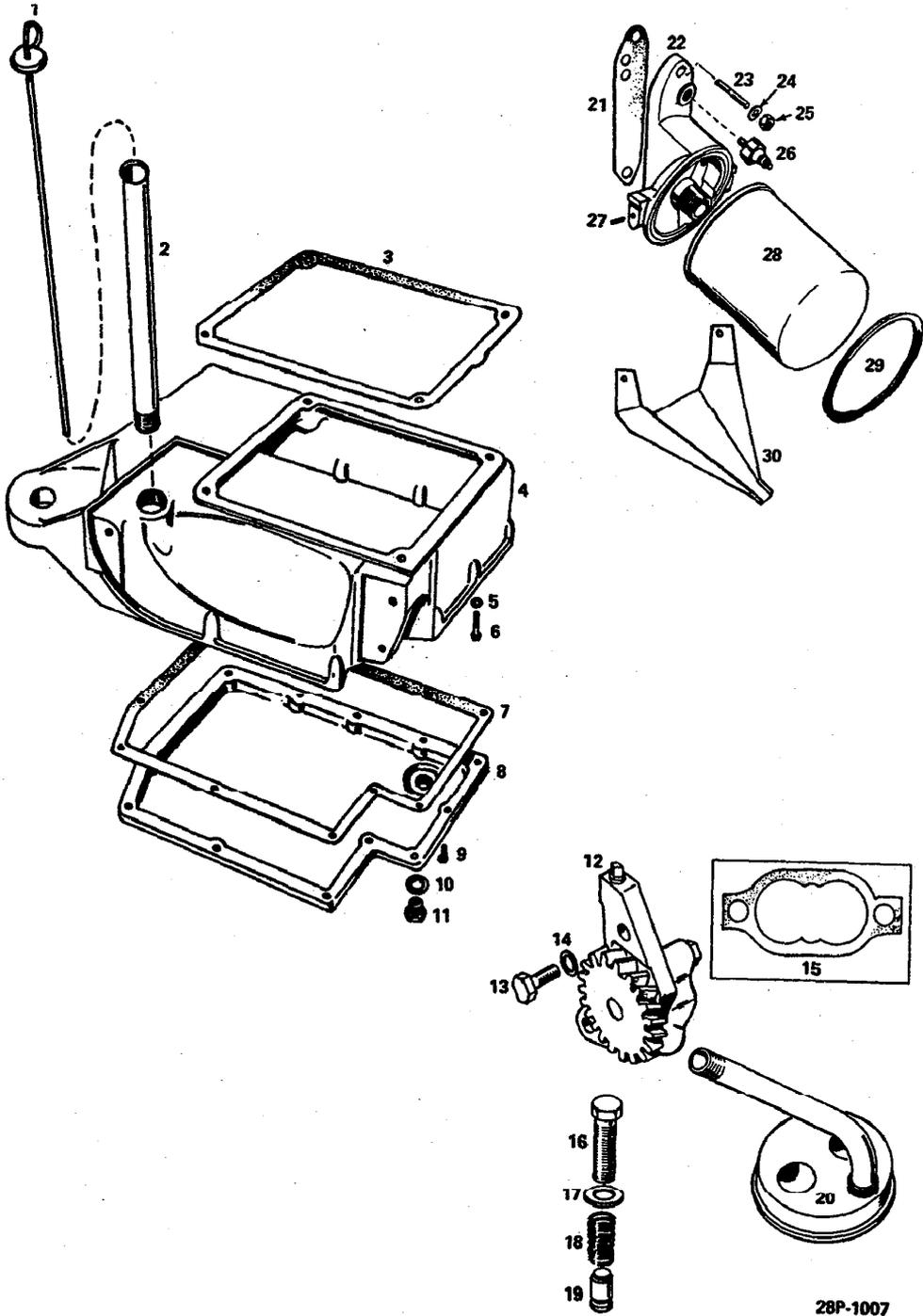

28P-1007

28.044J ONAN 4KW GENERATOR - OIL SYSTEM

FURNISHINGS

KEY 230 260 PART NUMBER

28.044J ONAN 4KW GENERATOR—OIL SYSTEM

1	1	1	707125	INDICATOR—oil filler (incl. cap) (SOA) (first design)
1	1	1	2000339	INDICATOR—oil filler (incl. cap) (must also use 2000350 tube) (second design)
1	1	1	2000350	TUBE—oil filler (must also use 2000339 indicator) (second design)
2	1	1	707283	TUBE—oil filler (first design)
3	1	1	* NS	GASKET—oil base mounting (ref. 707284) (102B693)
4	1	1	* NS	BASE—oil (ref. 707282) (102E711)
5	4	4	103321	WASHER—flat, oil base mounting (3/8")
6	4	4	—	SCREW—oil base, mounting (3/8—16 x 1-1/2) (procure locally)
7	1	1	707286	GASKET—oil pan
8	1	1	707285	PAN—oil
9	13	13	—	SCREW—oil pan, mounting (1/4—20 x 3/4") (procure locally)
10	1	1	* NS	GASKET—oil pan, plug (ref. 707288) (102P743)
11	1	1	* NS	PLUG—oil drain (ref. 707287) (102A716)
12	1	1	707126	PUMP—oil (SOA)
13	2	2	9419006	SCREW—oil pump mounting (1/4—20 x 1")
14	2	2	103319	WASHER—oil pump, mounting (1/4) (flat)
15	1	1	* NS	KIT—gasket, oil pump (ref. 707409) (120K161)
16	1	1	9427161	SCREW—oil by—pass valve, (3/8-24 x 1") (300M)
17	1	1	—	WASHER—oil by—pass valve, copper (3/8") (procure locally)
18	1	1	* NS	SPRING—oil by—pass valve (ref. 707289) (120A140)
19	1	1	* NS	VALVE—oil by—pass (ref. 707290) (120A398)
20	1	1	* 707 NS	INTAKE—oil pump (incl. cup) (SOA) (ref. 707129) (120A713)
21	1	1	707291	GASKET—oil filter, adapter
22	1	1	707127	ADAPTER—oil filter (SOA)
23	2	2	* NS	STUD—oil filter, adapter and mounting foot (ref. 707295) (520 - 824)
24	2	2	—	WASHER—flat, oil filter mounting, copper (5/16) (procure locally)
25	2	2	—	NUT—oil filter, adapter mounting (5/16—18) (procure locally) (repl. 124824)
26	1	1	707294	SWITCH—low oil pressure
27	2	2	* NS	PIN—drive, oil filter drain (ref. 707293) (516A72)
28	1	1	707128	FILTER—oil, spin—on (SOA)
29	1	1	* 707296	SEAL—oil filter, air
30	1	1	* NS	DRAIN—oil filter (ref. 707292) (122C360)

FURNISHINGS

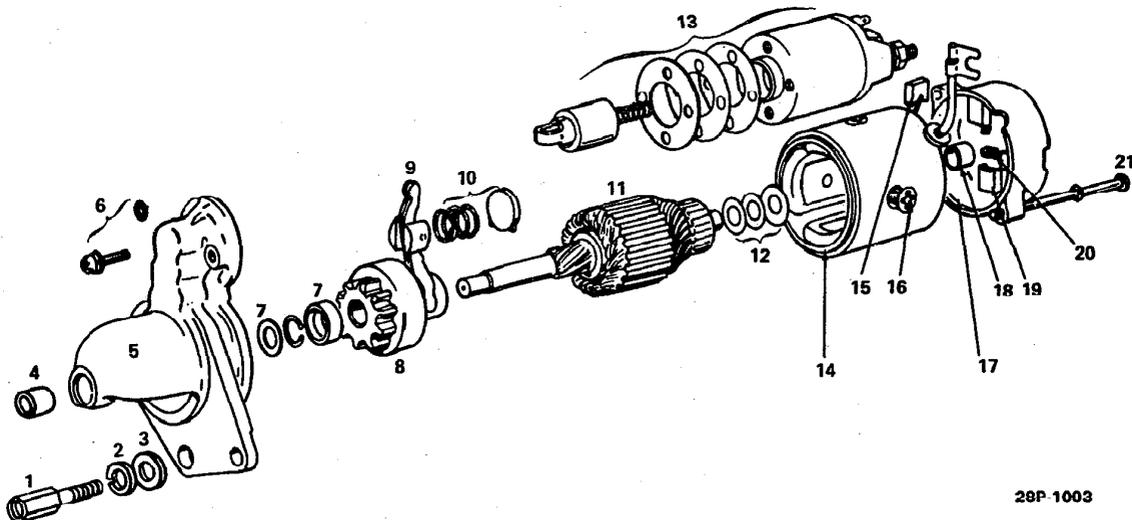

28P-1003

KEY 230 260 PART NUMBER

28.044K STARTING MOTOR—ONAN 4KW GENERATOR

KEY	230	260	PART NUMBER	DESCRIPTION
—	1	1	707103	MOTOR—starter (complete with solenoid)
1	2	2	* NS	STUD—starter motor (ref. 707194) (134A2592)
2	2	2	103320	WASHER—lock, starter motor mounting (5/16")
3	2	2	707195	WASHER—flat, starter mounting
4	1	1	* NS	BEARING—front (ref. 707205) (191 - 971)
5	1	1	* NS	BRACKET ASSY.—front (incl. bearing) (SOA) (ref. 707106) (191 - 970)
6	1	1	* NS	SCREW—set (ref. 707206) (191 - 982)
7	1	1	* NS	STOPPER—set, pinion (ref. 707204) (191 - 972)
8	1	1	* 707107	CLUTCH ASSY.—(SOA) (ref. 707107) (191 - 973)
9	1	1	* NS	LEVER ASSY.—(SOA) (ref. 707104) (191 - 965)
10	1	1	* NS	SPRING SET (ref. 707203) (191 - 966)
11	1	1	* NS	ARMATURE (ref. 707201) (191 - 974)
12	1	1	* NS	WASHER SET (ref. 707202) (191 - 975)
13	1	1	707105	SWITCH ASSY.—(solenoid)
14	1	1	* NS	YOKE ASSY.—(incl. bearing and brush) (SOA) (ref. 707108) (191 - 976)
15	1	1	* NS	BRUSH—rear (positive) (ref. 707200) (191 - 978)
16	4	4	707172	SCREW—flat head, machine
17	1	1	707109	BRACKET ASSY.—rear (incl. bearing and brush) (SOA)
18	1	1	* NS	BEARING—rear (ref. 707198) (191 - 980)
19	1	1	* NS	BRUSH—negative (ref. 707199) (191 - 981)
20	2	2	* NS	SPRING—brush (ref. 707197) (191 - 968)
21	2	2	707196	BOLT—through

FURNISHINGS

NOTES

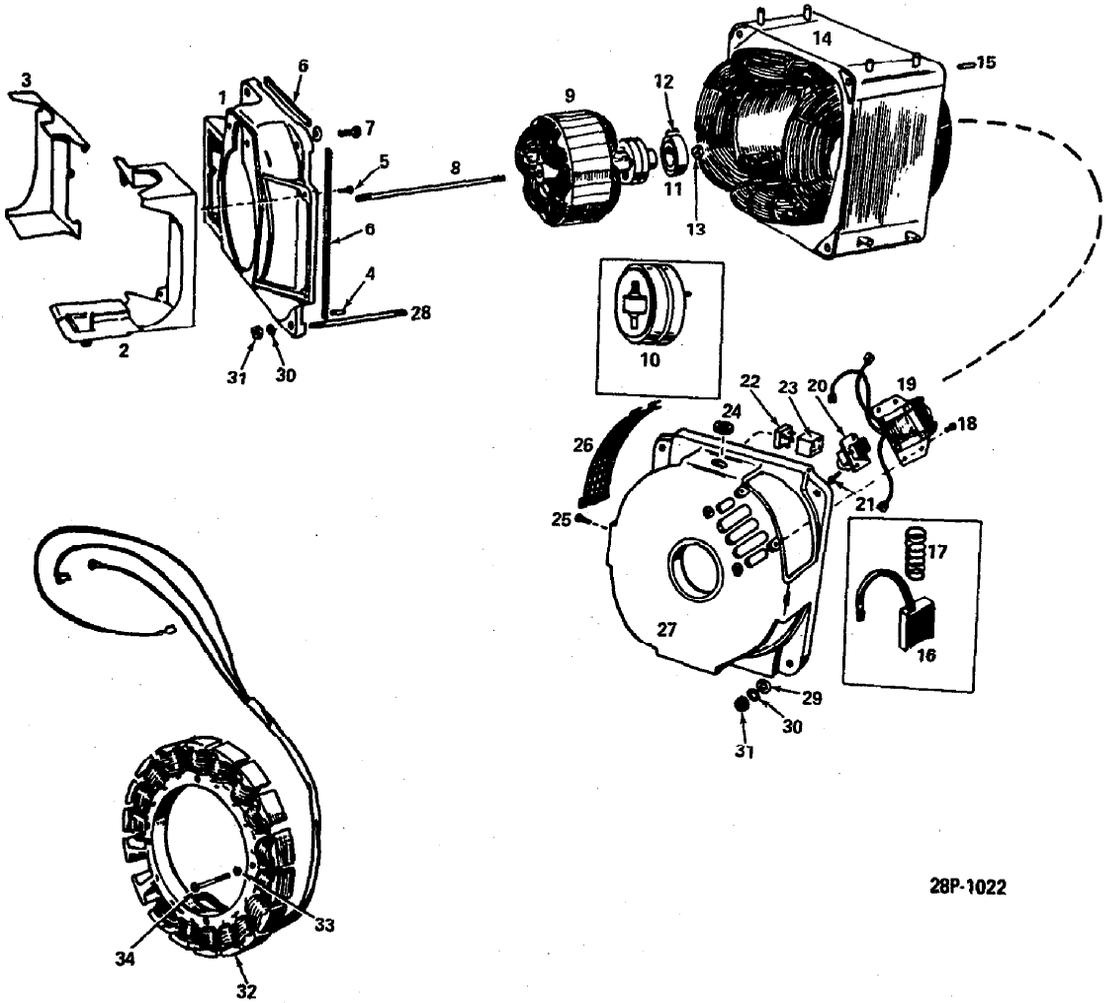

28P-1022

28.045 GENERATOR - ONAN 6KW

FURNISHINGS

KEY 230 260 PART NUMBER

28.045 GENERATOR—ONAN 6KW

—	—	1	706129	GENERATOR ASSY.—Onan 6KW (Onan No. 6NH—IR-9000A) (complete) (ref. only)
—	—	1	2001699	GENERATOR ASSY.—Onan 6KW (Onan No. 6NH—IR-9000E) (complete) (repl. 706129) (ref. only)
—	—	1	2002654	GENERATOR ASSY.—Onan 6KW (Onan No. 6NH—IR-9000G) (complete) (repl. 706129 & 2001699) (ref. only)
—	—	1	2010790	GENERATOR ASSY.—Onan 6KW (Onan No. 6.ONH—IR-9000H) (complete) (repl. 706129, 2001699 & 2002654)
1	—	1	707155	ADAPTER—control
2	—	1	710334	DUCT—generator air, starter baffle and oil filtered drain (RH)
3	—	1	701335	DUCT—generator air (LH)
4	—	4	707157	PIN—roll, generator adapter
5	—	6	—	SCREW—hex, air duct mounting (No. 10—32 x 3/8") (procure locally)
6	—	4	707156	SEAL—generator to adapter
7	—	4	—	SCREW—adapter mounting (3/8—16 x 1-1/4) (procure locally)
8	—	1	710336	STUD—rotor through
9	—	1	2025349	ARMATURE ASSY.—wound (incl. bearing and collector ring) (repl. 710303) (also use 1-2025351 frame & stator)
10	—	1	707159	RING—collector
11	—	1	707160	BEARING—ball
12	—	1	707161	CLIP—generator bearing stop
13	—	1	707162	NUT—rotor through stud
14	—	1	2025351	FRAME AND STATOR—wound (repl. 710341) (use w/2025349 armature assy.)
15	—	4	707157	PIN—roll, end bell
16	—	1	707169	BRUSH—block
17	—	1	707170	SPRING—brush block
18	—	4	—	SCREW—hex, reactor mounting (No. 10—32 x 7/8") (procure locally)
19	—	1	710343	REACTOR—compounding
20	—	2	707102	BLOCK ASSY.—(incl. brushes and springs)
21	—	4	—	SCREW—hex, brush block mounting (No. 10—32 x 7/8") (procure locally)
22	—	1	707164	BRIDGE—rectifier
23	—	1	707168	PLUG—rectifier bridge
24	—	1	707167	GROMMET—output leads
25	—	1	—	SCREW—hex, rectifier mounting (No. 8—32 x 1-1/4") (procure locally)
26	—	3	707166	SCREEN—end bell
27	—	1	707165	BELL—end
28	—	4	710345	STUD—generator mounting
29	—	4	—	WASHER—flat, generator through stud (5/16) (procure locally)
30	—	8	—	WASHER—lock, generator through stud (5/16) (procure locally)
31	—	8	707174	NUT—hex, generator through stud
32	—	1	707184	STATOR—charging alternator (w/706129 generator)
32	—	1	2000344	STATOR—charging alternator (w/2001699, 2002654, 2010790 generator)
33	—	3	707186	WASHER—stator mounting
34	—	3	707185	SCREW—stator mounting (No. 10—32 x 1-1/2)
—	—	1	710361	HARNESS—wiring alternator (w/706129 generator)
—	—	1	2000345	HARNESS—wiring alternator (w/2001699, 2002654 generator)
—	—	1	715810	HARNESS—generator to utility box (incl. receptical)
—	—	1	2000875	HARNESS ASSY.—generator compartment to utility box (eff. w/1975) (repl. 791121)
—	—	1	719649	SWITCH—remote on and off (interior) (repl. 714228)
—	—	1	2257158	SWITCH ASSY.—magnetic (at generator compartment) (eff. w/1975)
—	—	1	717015	GUARD—mud
—	—	2	* NS	SCREW—battery cable terminal (ref. 710770) (810 - 181)
—	—	4	* NS	NUT—battery cable terminal (ref. 710771) (871 - 25)
—	—	2	* NS	WASHER—battery cable terminal (ref. 710773) (508 - 19)
—	—	1	* NS	WASHER—battery cable terminal (ref. 707774) (508 - 7)
—	—	1	710624	GROMMET—battery cable thru pan
—	—	1	791841	SEAL ASSY.—bushing, at gen. compartment
—	—	1	2018214	BOX—outlet (w/2010790 generator)
—	—	1	2018215	COVER—outlet box (w/2010790 generator)
—	—	1	2018216	CONNECTOR—outlet box (w/2010790)
—	—	1	—	GASKET KIT—oil pump (see group 28.045F)
—	—	1	—	KIT—carbon removal (see group 28.045B)
—	—	1	—	KIT—gasket engine (see group 28.045B)
—	—	1	—	KIT—generator overhaul (see group 28.045B)

FURNISHINGS

KEY	230	260	PART NUMBER
-----	-----	-----	-------------

28.045 GENERATOR—ONAN 6KW (Cont.)

— — 1 — KIT—carburetor pre-heater (see group 28.045B)

FURNISHINGS

NOTES

FURNISHINGS

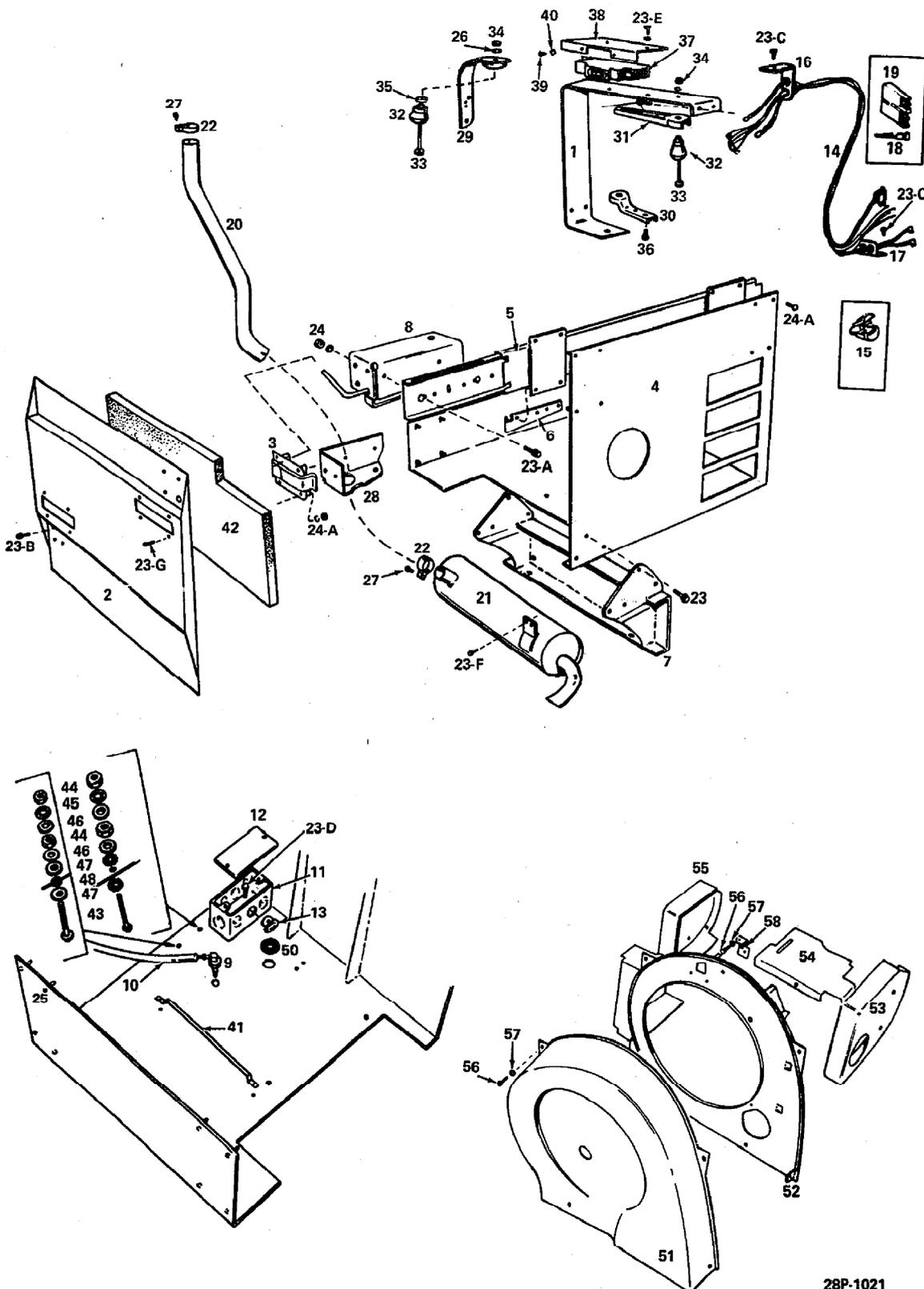

28.045A CHASSIS - ONAN 6KW GENERATOR

28P-1021

FURNISHINGS

KEY 230 260 PART NUMBER

28.045A CHASSIS—ONAN 6KW GENERATOR (INCLUDES: MUFFLER KIT)

1	—	1	710496	YOKE—generator support
2	—	1	710333	DOOR—slide out
3	—	2	NS	LATCH—door (ref. 707150) (406P639)
4	—	1	710517	PAN—mounting base
5	—	2	707152	SLIDE
6	—	2	707400	BRACKET—latch strike
7	—	1	710602	BRACKET—set mounting
8	—	1	710331	BRACKET AND CATCH ASSY.—safety
9	—	1	707405	CONNECTOR ELBOW—fuel line
10	—	1	707406	HOSE—fuel (w/706129 generator)
10	—	1	2002204	HOSE—fuel (w/2001699, 2002654 generator)
11	—	1	710605	BOX—junction
12	—	1	707403	COVER—junction box
13	—	2	707404	BUSHING—junction box (part of wiring harness)
14	—	1	707147	HARNES—wiring, chassis (w/706129 generator)
14	—	1	2000343	HARNES ASSY.—wiring, chassis (w/2001099, 2002654 generator)
14	—	1	2018213	HARNES ASSY.—wiring, chassis (w/2010790 generator)
15	—	4	707386	RELIEF—strain (part of wiring harness)
16	—	1	707390	BRACKET—harness mounting (part of wiring harness)
17	—	1	707387	BRACKET—harness mounting (part of wiring harness)
18	—	4	707389	CONTACT—connector (part of wiring harness)
19	—	1	707388	BODY—connector (part of wiring harness)
20	—	1	710493	TUBE—exhaust
21	—	1	707148	MUFFLER—exhaust (SOA)
—	—	1	2035386	KIT—muffler (w/2010790 generator assy.)
22	—	1	707384	CLAMP—exhaust
23	—	4	—	SCREW—hex, set mounting bracket to base pan (3/8 x 3/4) self locking (procure locally)
23A	—	8	—	SCREW—hex, slide rail (1/4—20 x 3/8") self locking (procure locally)
23B	—	6	—	SCREW—hex, door mounting (1/4—20 x 3/8") self locking (procure locally)
23C	—	3	—	SCREW—hex, wiring harness brackets mounting (1/4—20 x 3/8") (procure locally)
23D	—	3	—	SCREW—hex, junction box mounting (1/4—20 x 3/8) self locking (procure locally)
23E	—	2	—	SCREW—hex, circuit breaker bracket mounting (1/4—20 x 3/8") self locking (procure locally)
23F	—	2	—	SCREW—hex, muffler mounting (1/4—20 x 3/8") self locking (procure locally)
23G	—	8	—	SCREW—hex, door latch mounting (1/4—20 x 3/8") self locking (procure locally)
24	—	16	—	NUT—self locking, slide rail mounting (1/4—20) (procure locally)
24A	—	8	—	SCREW—self locking, door latch mounting (1/4—20) (procure locally)
25	—	16	707418	SCREW—press, slide rail mounting (1/4—20 x 3/4)
26	—	4	—	WASHER—lock, generator support mounting (3/8") (procure locally)
27	—	1	NS	BOLT—carriage, muffler clamp (ref. 710495) (816 - 152)
28	—	1	710603	BRACKET—engine end (LH)
29	—	1	710332	FOOT ASSY.—engine mounting (RH)
30	—	1	707392	SUPPORT—generator (LH)
31	—	1	707393	SUPPORT—generator (RH)
32	—	2	707394	END—engine
32A	—	2	710515	END—generator
33	—	4	707395	BOLT—cushion mounting
34	—	4	707417	NUT—self locking cushion mounting
35	—	1	707396	SPACER—cushion mounting engine end (RH)
36	—	4	—	SCREW—hex, generator support (3/8—16 x 1-1/4") (procure locally)
37	—	1	710499	BREAKER—circuit (w/706129, 2001699 gen.)
37	—	1	2003485	BREAKER—circuit (w/2002654, 2010790 gen.)
38	—	1	707398	BRACKET—circuit breaker mounting
39	—	2	—	SCREW—round head, circuit breaker mounting (No. 6—32 x 1/4") (procure locally)
40	—	2	—	WASHER—lock, circuit breaker mounting (No. 6) (procure locally)
41	—	1	710606	BRACKET—fuel line return
42	—	1	710623	INSULATION—door
43	—	2	710770	SCREW—round head brass, battery cable terminals (5/16—18 x 1-1/4")
44	—	4	710771	NUT—hex, brass, battery cable terminals (5/16—18)

FURNISHINGS

KEY 230 260 PART NUMBER

**28.045A CHASSIS—ONAN 6KW GENERATOR (INCLUDES: MUFFLER KIT)
(Cont.)**

45	—	2	—	WASHER—internal tooth, battery cable terminal (5/16") (procure locally)
46	—	4	—	WASHER—flat, battery cable terminals (5/16") (procure locally)
47	—	2	710773	WASHER—fiber, battery cable terminals (5/16")
48	—	1	710774	WASHER—fiber, battery cable terminals (5/16")
49	—	1	—	WASHER—external, internal tooth, battery cable terminals (5/16") (procure locally)
50	—	1	710624	GROMMET—battery cable through pan
50A	—	1	710772	GROMMET—harness bracket (part of wiring harness)
51	—	1	710362	COVER—blower housing scroll
52	—	1	710358	SCROLL—blower housing
53	—	1	NS	HOUSING—cylinder, air (RH) (ref. 710353) (134C2597)
54	—	1	710354	BAFFLE—cylinder, air (RH)
55	—	1	710352	HOUSING—cylinder, air (LH)
56	—	4	—	SCREW—hex, scroll cover mounting (1/4—20 x 1/2") (procure locally)
57	—	2	—	WASHER—lock, scroll cover mounting (1/4") (procure locally)
58	—	1	710359	BRACKET—scroll mounting
—	—	1	2000352	BOX—circuit breaker mounting (w/2003485 breaker)
—	—	1	2000353	COVER—circuit breaker mounting box (w/2003485 breaker)
—	—	1	2000354	GROMMET—cover, circuit breaker mounting box (w/2003485 breaker)

FURNISHINGS

NOTES

FURNISHINGS

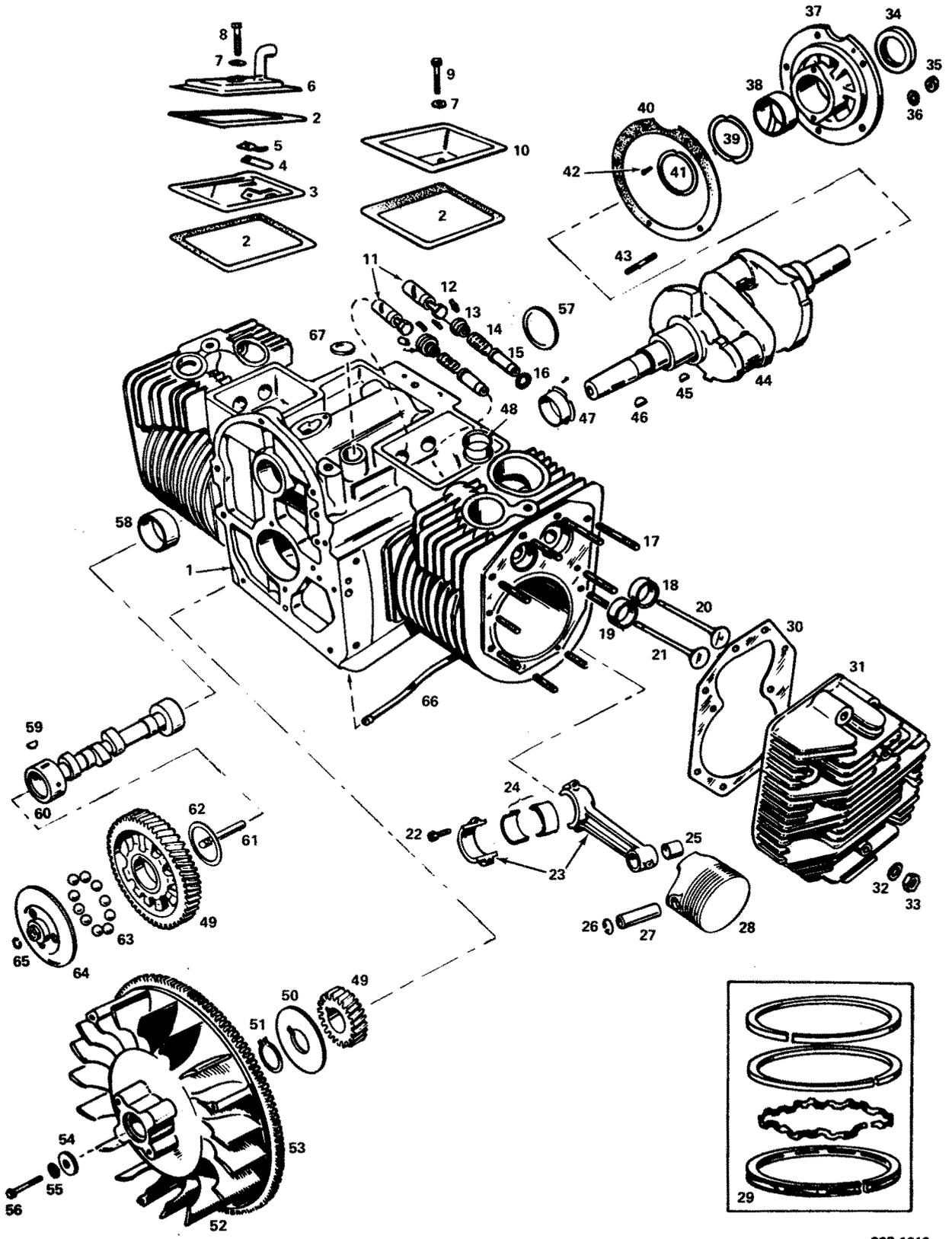

28.045B ONAN 6KW GENERATOR - CYLINDER BLOCK, CRANKSHAFT, FLYWHEEL, CAMSHAFT AND PISTON

28P-1016

FURNISHINGS

KEY 230 260 PART NUMBER

28.045B ONAN 6KW GENERATOR—CYLINDER BLOCK, CRANKSHAFT, CAMSHAFT AND PISTON

NOTE: Items marked with asterisk are part of Block Assembly plus intake and exhaust manifolds studs

1	—	1	710330	BLOCK ASSY.—cylinder
2	—	3	710482	GASKET—valve cover
3	—	1	* NS	BAFFLE—breather (ref. 710486) (123C1215)
4	—	1	710490	VALVE—breather
5	—	1	710491	STOP—breather valve
6	—	1	710492	COVER—valve compartment with tube for breather hose (LH)
7	—	2	* 9419892	WASHER—flat valve compartment cover (1/4", copper)
8	—	1	9419014	SCREW—hex. valve cover mounting (1/4—20 x 2")
9	—	1	* —	SCREW—hex. valve cover mounting (1/4—20 x 1-3/4") (procure locally)
10	—	1	710483	COVER—valve compartment without tube for breather hose (RH)
11	—	4	707362	TAPPET—valve, standard
11	—	4	707363	TAPPET—valve, .005" oversize
12	—	8	707361	LOCK—valve and spring retainer
13	—	4	NPN	ROTOR CAP—valve spring
14	—	4	707359	SPRING—valve
15	—	4	* 710742	GUIDE—valve
16	—	2	* 707357	GASKET—valve guide (intake)
17	—	8	* 710756	STUD—cylinder head (3/8 x 2—3/4")
18	—	2	* 710719	INSERT—valve seat (intake) standard
18	—	2	710730	INSERT—valve seat .002" oversize
18	—	2	710734	INSERT—valve seat .005" oversize
18	—	2	710735	INSERT—valve seat .010" oversize
18	—	2	710737	INSERT—valve seat .025" oversize
19	—	2	* 710709	INSERT—valve seat (exhaust) standard
19	—	2	710713	INSERT—valve seat, .002" oversize
19	—	2	710716	INSERT—valve seat, .005" oversize
19	—	2	710717	INSERT—valve seat, .010" oversize
19	—	2	710718	INSERT—valve seat, .025" oversize
20	—	2	710476	VALVE—intake
21	—	2	710477	VALVE—exhaust
22	—	4	710694	BOLT—connecting rod cap
23	—	2	710321	ROD ASSY.—(incl. bushing and bolts)
24	—	4	710411	BEARING HALF—connecting rod, standard
24	—	4	710412	BEARING HALF—connecting rod, .002" undersize
24	—	4	710413	BEARING HALF—connecting rod, .010" undersize
24	—	4	710419	BEARING HALF—connecting rod, .020" undersize
24	—	4	710458	BEARING HALF—connecting rod, .030" undersize
25	—	2	710693	BUSHING—piston pin, connecting rod
26	—	4	3778828	RING—piston pin retaining
27	—	2	710695	PIN—piston, standard
27	—	2	710701	PIN—piston, .002" oversize
28	—	2	* NS	PISTON AND PIN—(incl. retaining rings) standard (ref. 710322) (112 - 111)
28	—	2	710323	PISTON AND PIN—(incl. retaining rings) .005" oversize
28	—	2	710324	PISTON AND PIN—(incl. retaining rings) .010" oversize
28	—	2	710325	PISTON AND PIN—(incl. retaining rings) .020" oversize
28	—	2	710326	PISTON AND PIN—(incl. retaining rings) .030" oversize
28	—	2	710327	PISTON AND PIN—(incl. retaining rings) .040" oversize
29	—	2	710459	RING SET—piston, standard
29	—	2	710460	RING SET—piston, .005" oversize
29	—	2	710461	RING SET—piston, .010" oversize
29	—	2	710462	RING SET—piston, .020" oversize
29	—	2	710465	RING SET—piston, .030" oversize
29	—	2	710467	RING SET—piston, .040" oversize
30	—	2	710474	GASKET—cylinder head
31	—	1	710470	HEAD—cylinder (No. 2 cylinder)
31	—	1	710471	HEAD—cylinder (No. 1 cylinder)
32	—	20	120394	WASHER—flat, cylinder head stud (3/8" steel)
33	—	20	—	NUT—hex, cylinder head (3/8—24) (procure locally) (ref. 124925)
34	—	1	* 707355	SEAL—bearing plate
35	—	5	124925	NUT—hex, rear bearing plate (3/8—24)
36	—	5	710753	WASHER—flat, rear bearing plate mounting (3/8" steel)

FURNISHINGS

KEY 230 260 PART NUMBER

28.045B ONAN 6KW GENERATOR—CYLINDER BLOCK, CRANKSHAFT,
(Cont.)

37	—	1	*	710707	PLATE—rear bearing (excludes bearing)
38	—	1	*	707346	BEARING—crankshaft, rear, standard
38	—	1		707347	BEARING—crankshaft, rear, .002" undersize
38	—	1		707348	BEARING—crankshaft, rear, .010" undersize
38	—	1		707349	BEARING—crankshaft, rear, .020" undersize
38	—	1	*	707350	BEARING—crankshaft, rear, .030" undersize
39	—	AR	*	707352	SHIM—rear bearing plate (.005")
40	—	1	*	707353	GASKET—bearing plate
41	—	2	*	707351	WASHER—crankshaft bearing thrust
42	—	4	*	707293	PIN—main bearing stop
43	—	5	*	710755	STUD—rear bearing plate mounting (3/8 x 1—21/32")
44	—	1	*	NS	CRANKSHAFT—(w/706129, 2001699 generator) (ref. 710409) (104D843)
44	—	1		2003483	CRANKSHAFT—(w/2002654, 2010790 generator)
45	—	1		707297	KEY—crankshaft gear mounting
46	—	1		707306	KEY—flywheel mounting (w/706129, 2001699 generator)
46	—	1		2003484	KEY—flywheel mounting (w/2002654 generator)
47	—	1	*	707339	BEARING—crankshaft front, standard
47	—	1		707340	BEARING—crankshaft front, .002" undersize
47	—	1		707341	BEARING—crankshaft front, .010" undersize
47	—	1		707342	BEARING—crankshaft front, .020" undersize
47	—	1		707343	BEARING—crankshaft front, .030" undersize
48	—	2		710484	INSERT—exhaust port
49	—	1		707300	GEAR SET—timing (incl. camshaft and crankshaft gears)
50	—	1		707307	WASHER—crankshaft gear retaining
51	—	1		707308	LOCK—crankshaft gear washer
52	—	1		710329	FLYWHEEL—(incl. ring gear and magnet ring)
53	—	1		710705	GEAR—ring, flywheel
54	—	1		710410	WASHER—flat, flywheel mounting
55	—	1		707311	WASHER—lock, flywheel mounting
56	—	1		—	SCREW—hex, flywheel mounting (7/16—14 x 4") (procure locally)
57	—	1	*	707345	PLUG—camshaft expansion
58	—	2	*	NS	BEARING—camshaft (precision) (ref. 710480) (101A405)
59	—	1		707297	KEY—camshaft gear mounting
60	—	1	*	NS	CAMSHAFT—(incl. center pin) (ref. 710328) (105B382)
61	—	1		707298	PIN—camshaft, center
62	—	1		707299	WASHER—camshaft gear thrust
63	—	10		707301	BALL—fly, governor
64	—	1		707302	CUP—governor
65	—	1		707303	RING—camshaft center pin
66	—	1		710708	TUBE—crankcase oil
67	—	1		710706	PLUG—core hole
—	—	1		711492	PLATE—governor ball
—	—	1		711493	SPACER—governor ball
—	—	1	*	NS	KIT—gasket, engine (ref. 710629) (168K125)
—	—	1		794579	GEAR—crankshaft (part of 707300 gear set)
—	—	1		794580	GEAR—camshaft (part of 707300 gear set)
—	—	1		710628	KIT—carbon removal gasket
—	—	1	*	NS	KIT—generator overhaul (ref. 710643) (522K270)
—	—	1		2018248	KIT—carburetor pre-heater (w/2010790 generator)

FURNISHINGS

NOTES

FURNISHINGS

KEY 230 260 PART NUMBER

28.045C FUEL SYSTEM—ONAN 6KW GENERATOR

1	—	4	710379	STUD—intake manifold
1	—	2	707249	STUD—carburetor mounting
1	—	4	710371	STUD—exhaust manifold mounting
2	—	2	710378	GASKET—intake and exhaust manifold
3	—	2	—	WASHER—lock, air cleaner adapter to bracket (1/4") (procure locally)
3	—	2	—	WASHER—lock, air cleaner adapter mounting (No. 8) (procure locally)
3	—	2	—	WASHER—lock, exhaust flange to manifold (5/16") (procure locally)
3	—	2	—	WASHER—carburetor mounting (1/4") (procure locally)
3	—	2	—	WASHER—lock, choke mounting (1/4") (procure locally)
3	—	4	—	WASHER—lock, intake manifold mounting (3/8") (procure locally)
3	—	2	—	WASHER—lock, choke plate mounting (1/4") (procure locally)
3	—	4	—	WASHER—lock, exhaust manifold mounting (3/8") (procure locally)
3	—	2	—	WASHER—lock, fuel pump hole cover mounting (1/4") (procure locally)
4	—	2	* NS	NUT—hex, exhaust tube to manifold (5/16—18) (ref. 707174) (862 - 15)
4	—	4	—	NUT—hex, intake manifold mounting (3/8—24) (procure locally)
4	—	4	—	NUT—hex, exhaust manifold mounting (3/8—24) (procure locally)
4	—	2	—	NUT—hex, carburetor mounting (1/4—28) (procure locally)
4	—	2	—	NUT—hex, choke mounting (1/4—20) (procure locally)
5	—	1	710366	MANIFOLD—exhaust
6	—	1	707241	CHOKE piece
7	—	4	—	SCREW—hex cap, fuel pump and regulator bracket mounting (No. 10—32 x 5/16") (procure locally) (ref. 707263)
7	—	1	—	SCREW—hex cap, choke swivel (No. 8—32 x 5/16") (procure locally)
7	—	2	—	SCREW—hex cap, fuel pump hole cover mounting (1/4—20 x 5/8") (procure locally)
7	—	2	—	SCREW—hex cap, choke plate mounting (1/4—20 x 5/8") (procure locally)
7	—	2	—	SCREW—hex cap, exhaust flange to manifold (5/16—18 x 1") (procure locally)
7	—	2	—	SCREW—hex cap, air cleaner adapter to bracket (1/4—20 x 5/8") (procure locally)
8	—	1	707242	SWIVEL—choke linkage
9	—	1	* NS	WASHER—flat, choke swivel (ref. 710388) (526 - 15)
9	—	1	* NS	WASHER—flat, air cleaner mounting (ref. 710393) (526A52)
10	—	1	—	PIN—cotter, choke swivel (procure locally)
11	—	1	710367	PLATE—choke mounting
12	—	1	* NS	LINKAGE—choke (ref. 710368) (153A455)
13	—	1	* NS	MANIFOLD—intake (ref. 710377) (154B1547)
14	—	1	707248	GASKET—carburetor mounting
15	—	1	710378	GASKET—intake & exhaust manifold (repl. 710370)
16	—	1	710369	FLANGE—exhaust outlet
17	—	1	710382	HOSE—breather
18	—	1	710305	CARBURETOR
19	—	1	710380	ELBOW—carburetor inlet (repl. 707261)
20	—	1	710383	GASKET—air cleaner adapter
21	—	1	710384	ADAPTER—carburetor to inlet hose
22	—	2	—	SCREW—fillister head, air cleaner adapter mounting (No. 8—32 x 7/8) (procure locally)
23	—	2	710385	CLAMP—air inlet hose
24	—	1	710381	LINE—flex, fuel
25	—	1	710387	BRACKET—air cleaner mounting
26	—	1	710386	HOSE—air inlet
27	—	1	710390	NUT—wing, air cleaner
28	—	1	710306	ADAPTER—air cleaner (SOA)
29	—	1	710391	ELEMENT—air cleaner
30	—	1	710392	BOLT—air cleaner mounting
31	—	1	707262	BRACKET—fuel pump and regulator mounting
32	—	1	793987	REGULATOR—12 volt (repl. 707182)
33	—	1	710394	ELBOW—fuel pump outlet
34	—	1	707261	ELBOW—fuel pump inlet
35	—	2	—	SCREW—self locking, fuel pump mounting (1/4—20 x 3/8") (procure locally)
36	—	1	707120	PUMP—fuel (for details see group 28.044E)
37	—	1	710396	COVER—fuel pump hole in cylinder block
38	—	1	710395	GASKET—fuel pump hole cover

FURNISHINGS

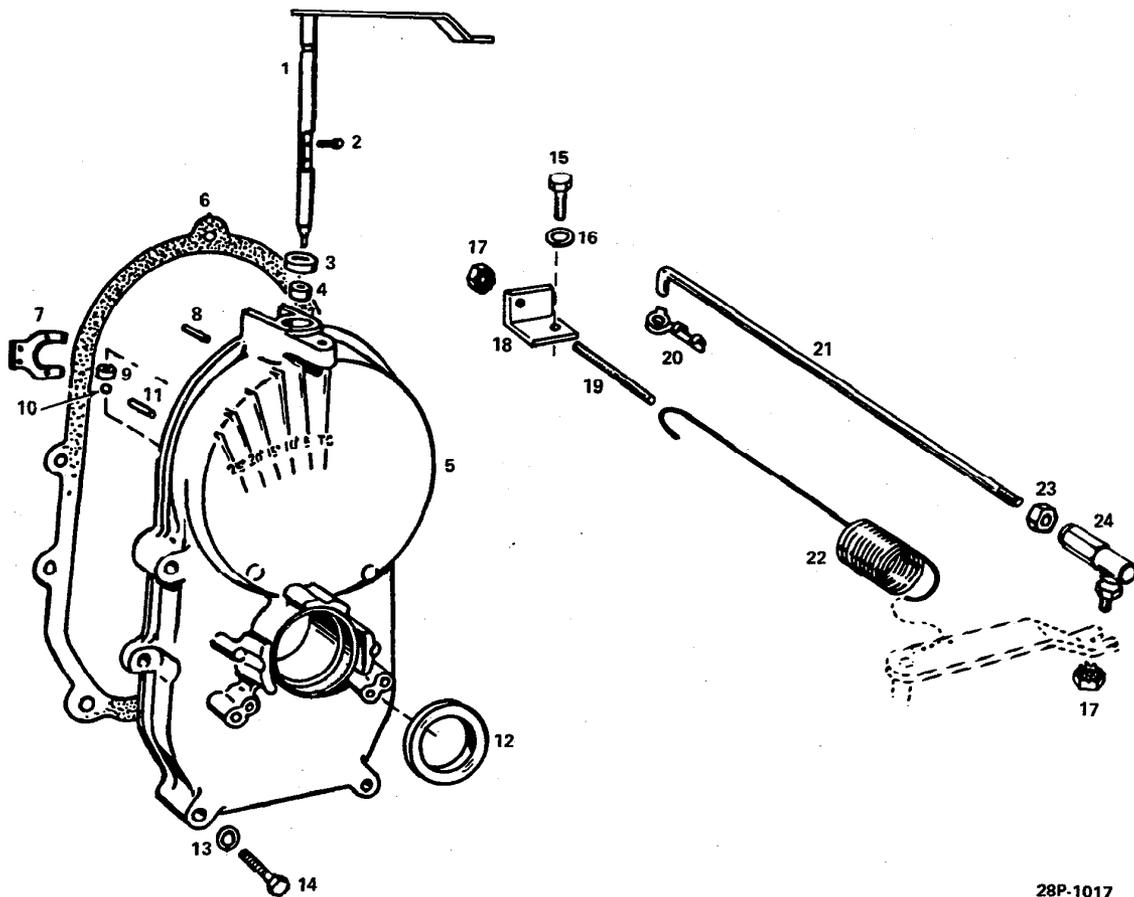

28P-1017

28.045D GEAR COVER AND GOVERNOR – ONAN 6KW GENERATOR

28.045D GEAR COVER AND GOVERNOR—ONAN 6KW GENERATOR

NOTE: Items marked with asterisk are part of Cover Assembly

1	—	1	*	710691	SHAFT AND ARM ASSY.—governor (SOA)
2	—	2	*	707276	SCREW—yoke, retaining
3	—	1	*	707274	SEAL—oil, governor shaft
4	—	1	*	707273	BEARING—governor shaft (upper)
5	—	1	*	NS	COVER ASSY.—gear (ref. 710309) (103B418)
6	—	1		710397	GASKET—gear cover mounting
7	—	1	*	707275	YOKE—governor shaft
8	—	2		—	PIN—gear cover (5/16 x 1-1/8") (procure locally)
9	—	1	*	707281	BEARING—governor shaft (lower)
10	—	1	*	707280	BALL—bearing, governor shaft
11	—	1	*	707278	PIN—governor cup stop
12	—	1	*	707279	SEAL—gear cover
13	—	5		—	WASHER—flat, gear cover mounting (5/16) (procure locally)
14	—	4		—	SCREW—hex, gear cover mounting (5/16-18 x 1-3/4") (procure locally)
15	—	1		—	SCREW—hex, governor bracket mounting (1/4-20 x 5/8) (procure locally)
16	—	1		—	WASHER—lock, governor bracket mounting (1/4) (procure locally)
17	—	2		707181	NUT—keps, governor ball joint and adjusting stud
18	—	1		710348	BRACKET—governor spring adjusting
19	—	1		710079	STUD—governor adjusting
20	—	1		707176	CLIP—governor control rod
21	—	1		710346	ROD—governor control
22	—	1	*	NS	SPRING—governor (ref. 710347) (150A1389)
23	—	1		707180	PALNUT—governor rod
24	—	1		707179	JOINT—ball, governor

FURNISHINGS

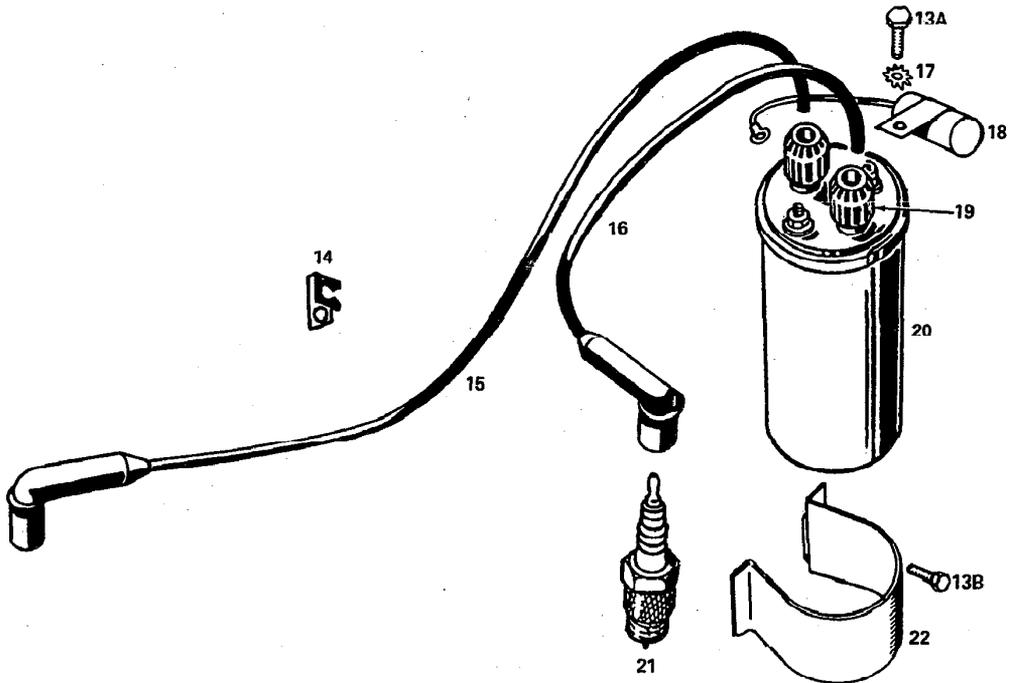
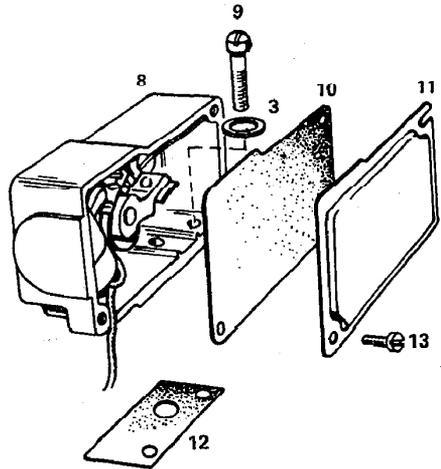
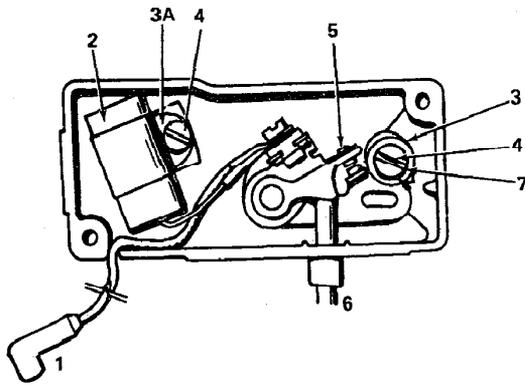

28.045E IGNITION – ONAN 6KW GENERATOR

28P 1010

FURNISHINGS

KEY 230 260 PART NUMBER

28.045E IGNITION—ONAN 6KW GENERATOR

1	—	1	707111	LEAD ASSY.—points to coil (SOA) (w/out 2010790 gen. assy.)
1	—	1	2018220	WIRE—coil to points (breaker box) (w/2010790 gen. assy.)
2	—	1	707217	CONDENSER—breaker points (w/out 2010790 gen. assy.)
2	—	1	2018218	CAPACITOR—ignition breaker box (w/2010790 gen. assy.)
3	—	2	—	WASHER—lock, breaker box mounting (1/4") (procure locally)
3A	—	2	—	WASHER—lock, breaker points and condenser mounting (No. 8) (procure locally)
4	—	2	—	SCREW—slotted pan head breaker points and condenser mounting (No. 8—32 x 3/8) (procure locally)
5	—	1	707218	POINT SET—breaker (w/out 2010790 gen. assy.)
5	—	1	2017798	POINT ASSY.—breaker box (w/2010790 gen. assy.)
6	—	1	707219	PLUNGER
7	—	1	—	WASHER—flat, point set mounting (No. 8) (procure locally)
8	—	1	707110	BOX ASSY.—breaker (w/out 2010790 gen. assy.)
8	—	1	2018212	KIT—breaker box (incl. cover, Points, capacitor etc) (w/2010790 gen. assy.)
9	—	2	—	SCREW—fillister phillips head, breaker box mounting (1/4—20 x 5/8) (procure locally)
10	—	1	707220	GASKET—breaker box cover
11	—	1	707221	COVER—breaker box (w/out 2010790 gen. assy.)
11	—	1	2018217	COVER—breaker box (w/2010790 gen. assy.)
12	—	1	707216	GASKET—breaker box mounting
13	—	2	—	SCREW—breaker box cover mounting (No. 8—32 x 3/8) (procure locally)
13A	—	1	707382	SCREW—condenser mounting (No. 10—32 x 1/2")
13B	—	1	707209	SCREW—coil clamp mounting (No. 10—32 x 3/8")
14	—	1	707214	SUPPORT—spark plug cable
15	—	1	710365	CABLE—spark plug (2 1")
16	—	1	710364	CABLE—spark plug (8 1/2 in.)
17	—	1	707211	WASHER—shake proof, condenser mounting (No. 10)
18	—	1	707210	CONDENSER—ignition
19	—	2	710363	CAP—ignition coil (part of coil)
20	—	1	2021066	COIL—ignition (repl. 707207)
21	—	2	5612073	PLUG—spark (repl. 707215)
22	—	1	707208	CLAMP—coil mounting
—	—	1	2018219	BASE—breaker box (w/2010790 gen. assy.)

FURNISHINGS

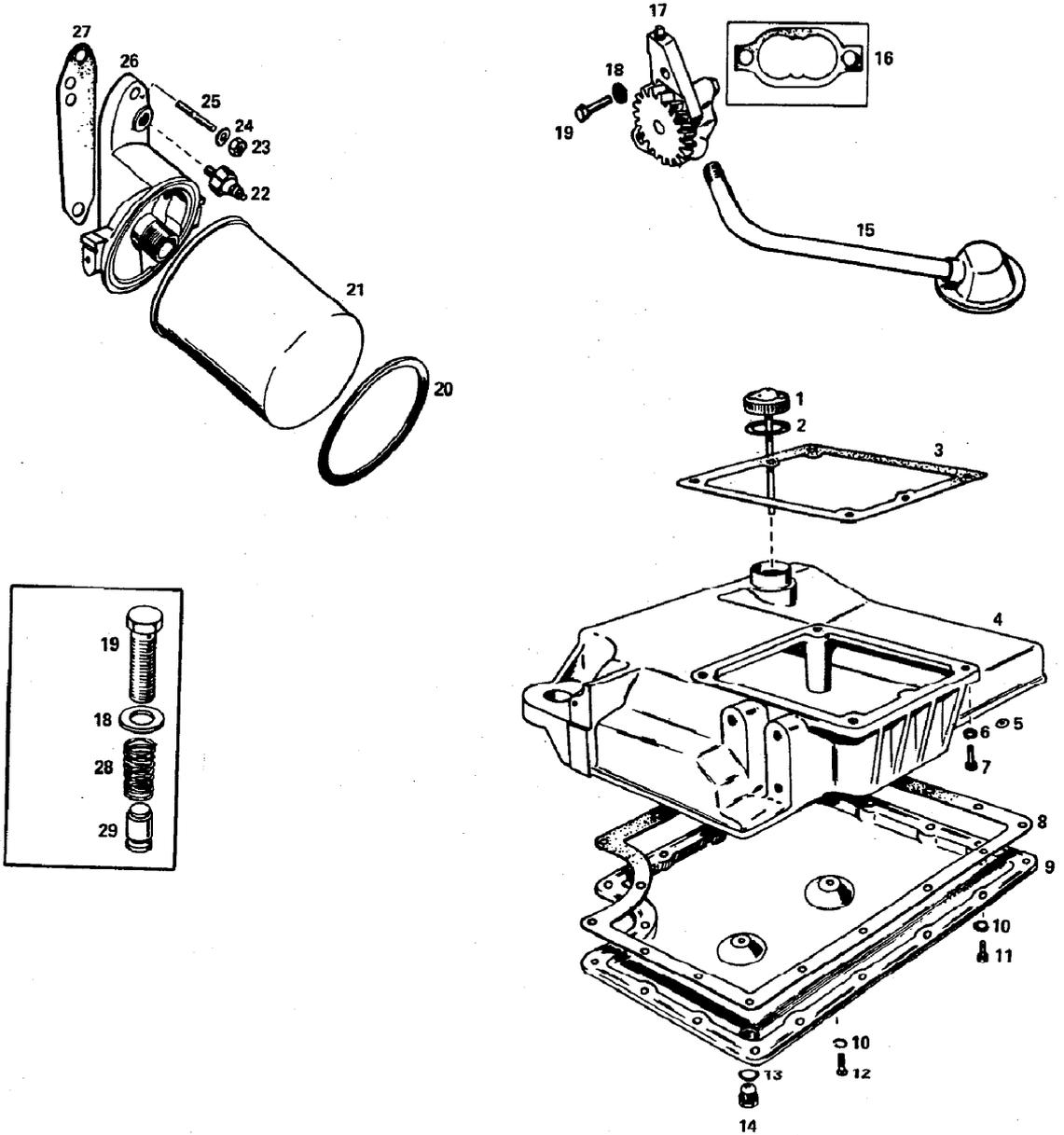

28.045F 6KW GENERATOR - OIL SYSTEM

28P-1018

FURNISHINGS

KEY 230 260 PART NUMBER

28.045F ONAN 6KW GENERATOR—OIL SYSTEM

1	—	1	*	NS	CAP AND INDICATOR—oil fill (incl. gasket) (ref. 710314) (123A1166)
2	—	1	*	NS	GASKET—oil fill cap and indicator (ref. 710692) (123A191)
3	—	1		710399	GASKET—oil base mounting
4	—	1		710398	BASE—oil
5	—	2		—	WASHER—flat, oil base mounting (3/8") (procure locally)
6	—	2		—	WASHER—lock, oil base mounting (3/8") (procure locally)
7	—	2		—	SCREW—hex, oil base mounting (3/8—16 x 4") (procure locally)
8	—	1		710404	GASKET—oil pan
9	—	1		710405	PAN—oil
10	—	19		—	WASHER—lock, oil pan mounting (1/4") (procure locally)
11	—	18		—	SCREW—hex, oil pan mounting (1/4—20 x 5/8") (procure locally)
12	—	2		—	SCREW—hex, oil pan mounting (1/4—20 x 1) (procure locally)
13	—	1		710407	GASKET—oil drain plug
14	—	1	*	NS	PLUG—oil drain (ref. 710406) (102A737)
15	—	1		710320	INTAKE—oil pump (incl. cup, screen and pipe) (SOA)
16	—	1		707409	GASKET KIT—oil pump
17	—	1		707126	PUMP—oil, complete (NOTE: Internal part not sold separately) (SOA)
18	—	2		—	WASHER—lock, oil pump mounting (1/4") (procure locally)
19	—	2		—	SCREW—hex, oil by—pass valve (3/8-24 x 1") (procure locally)
20	—	1		707296	SEAL—oil filter, air
21	—	1		710319	FILTER—oil, spin—on (SOA)
22	—	1		707294	SWITCH—low oil pressure
23	—	2		—	NUT—oil filter, adapter mounting (5/16—18) (procure locally)
24	—	2		—	WASHER—flat, oil filter adapter mounting (5/16) (procure locally)
25	—	2		710408	STUD—oil filter, adapter and mounting floor
26	—	1		710318	ADAPTER—oil filter (SOA)
27	—	1		707291	GASKET—oil filter adapter
28	—	1		707289	SPRING—oil by—pass
29	—	1		707290	VALVE—oil by—pass

FURNISHINGS

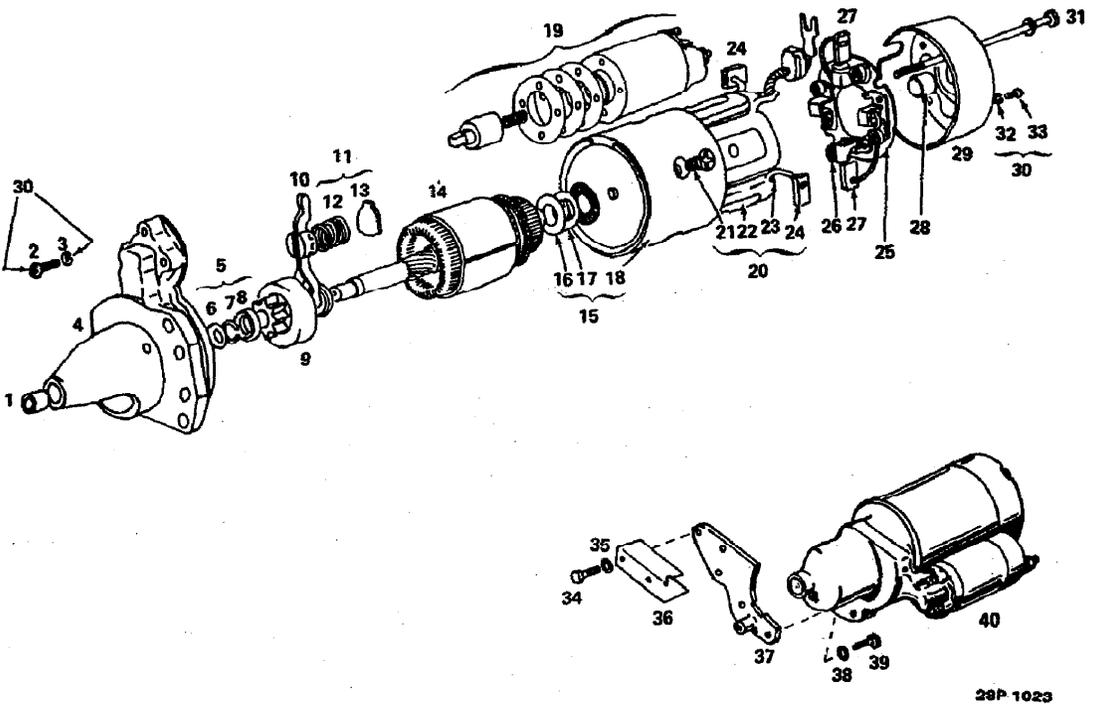

28P-1023

28.045G MOTOR - STARTING ONAN 6KW GENERATOR

FURNISHINGS

KEY 230 260 PART NUMBER

28.045G MOTOR—STARTING, ONAN 6KW GENERATOR

NOTE: Items marked with asterisk are part of Screw Set.

—	—	1	710304	MOTOR ASSY.—starting — complete with solenoid (w/706129, 2001699 generator)
—	—	1	2003482	MOTOR ASSY.—starting (complete) (w/2002654, 2010790 generator) (details not available at time of publication)
—	—	1	2033074	SHIELD—solenoid
1	—	3	710658	BEARING—front
2	—	1	710680	* SCREW—machine, pan head
3	—	5	710681	* WASHER—lock
4	—	1	710646	BRACKET ASSY.—front (incl. bearing)
5	—	1	710651	STOPPER SET—pinion (incl. washer, ring and stopper)
6	—	1	710662	WASHER—flat
7	—	1	710663	RING—retaining
8	—	1	710664	STOPPER—pinion
9	—	1	NS	* CLUTCH ASSY.—(SOA) (ref. 710648) (191 - 995)
10	—	1	710644	LEVER ASSY.—(SOA)
11	—	1	NS	* SPRING SET (ref. 710652) (191 - 984)
12	—	1	710668	SPRING—lever
13	—	1	710669	PACKING
14	—	1	710653	ARMATURE
15	—	1	710654	WASHER SET—(incl. 2 plain and 1 insulated washer)
16	—	1	710672	WASHER—plain
17	—	1	710673	WASHER—plain
18	—	1	710674	WASHER—insulating
19	—	1	710645	SWITCH ASSEMBLY—(SOA) (solenoid)
20	—	1	NS	* COIL SET—field (incl. pole shoes, field coil, brushes and screws)(191 - 1001)
21	—	4	710675	SCREW—flat head
22	—	4	710677	POLE—shoe, field coil
23	—	1	710678	COIL—field
24	—	2	NS	* BRUSH—positive, field coil (ref. 710679) (191 - 1005)
25	—	1	710649	HOLDER ASSY.—brush (incl. brushes and springs)
26	—	4	710659	SPRING—brush, holder
27	—	2	NS	* BRUSH—negative, holder (ref. 710660) (191 - 1008)
28	—	1	710661	BEARING—rear
29	—	1	710650	BRACKET ASSEMBLY—rear (incl. bearing)
30	—	1	710656	* SCREW SET
31	—	2	710657	BOLT—through
32	—	2	710684	* WASHER—lock
33	—	2	710688	* SCREW—machine pan head
34	—	2	—	SCREW—hex cap, bracket mounting (3/8—16 x 1-1/4) (procure locally)
35	—	2	—	WASHER—starting motor bracket mounting (3/8") (procure locally)
36	—	1	710349	BRACKET—muffler and starting motor baffle
37	—	1	710351	BRACKET—starting motor mounting
38	—	2	—	SCREW—starting motor to bracket (3/8—16 x 1-1/4") (procure locally)
39	—	2	—	WASHER—starting motor to bracket (3/8") (procure locally)

FURNISHINGS

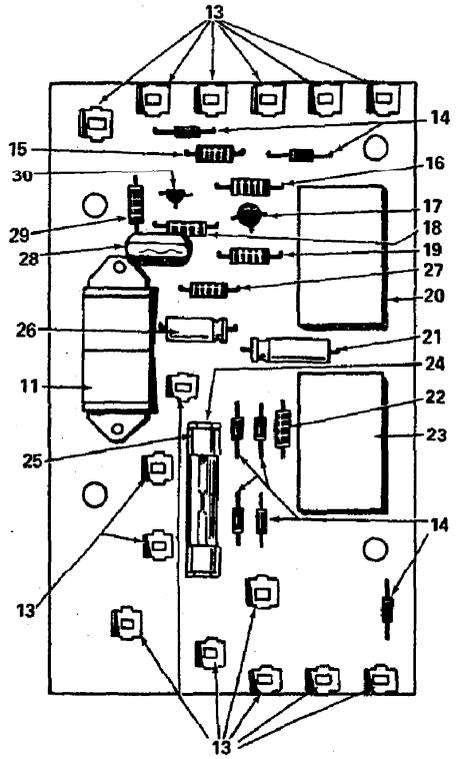
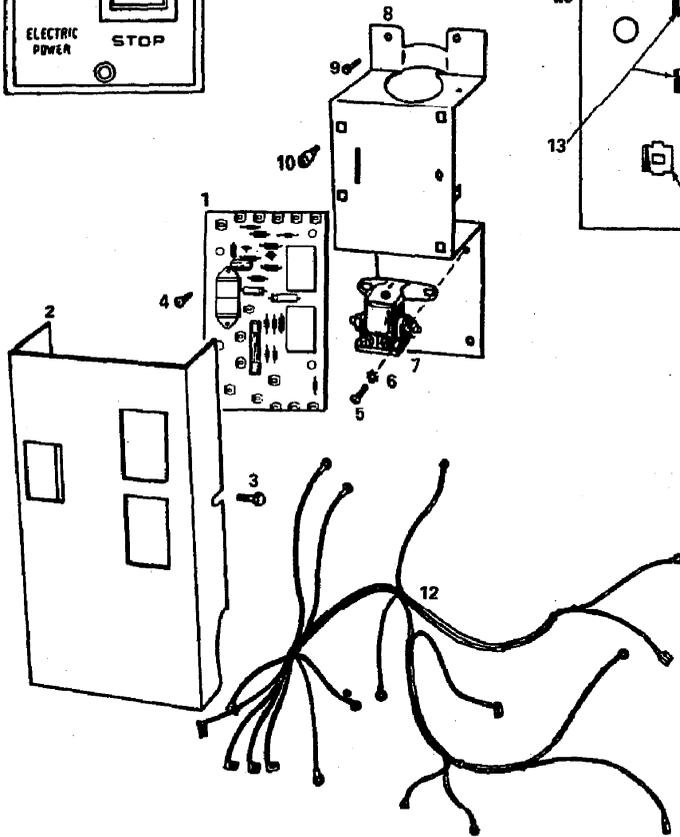
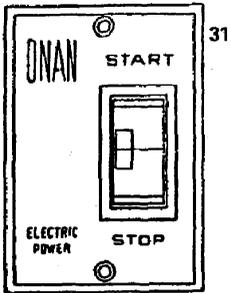
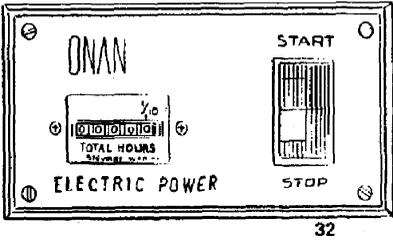

28.045H CONTROL - ONAN 6KW GENERATOR

FURNISHINGS

KEY 230 260 PART NUMBER

28.045H CONTROL—ONAN 6KW GENERATOR

1	1	1	793986	CONTROL ASSY.—generator (w/706129 generator) (repl. 707144)
1	1	1	2000341	CONTROL ASSY.—generator (incl. harness) (incl. 793986 control and 2000362 harness) (w/2001699, 2002654, 2010790 generator)
2	1	1	707381	COVER—control
3	2	2	707382	SCREW—control cover mounting (No. 10 x 1/2") (hex)
4	4	4	—	SCREW—sheet metal, control to bracket (No. 8 x 1") (procure locally)
5	2	2	—	SCREW—round head, start solenoid mounting (1/4—20 x 3/8") (procure locally)
6	2	2	707371	WASHER—start solenoid mounting shake proof
7	1	1	707143	RELAY—start solenoid
8	1	1	707370	BRACKET—control and coil, mounting
9	4	4	—	SCREW—control bracket mounting (procure locally) (ref. 707263)
10	4	4	707372	NUT—insulating control to bracket
11	1	1	NS	SWITCH (ref. 710379) (308A320)
12	1	1	707145	HARNESS—wiring, control to engine (w/793986 control)
12	1	1	2000342	HARNESS—wiring, control to engine (SOA) (w/2000341 control)
13	15	15	707380	TAB—stake
14	7	7	707374	RECTIFIER—silicon
15	1	1	707378	RESISTOR—(330—OHM-1/2 watt)
16	1	1	710766	RESISTOR—(470—OHM-1/2 watt)
17	1	1	710764	TRANSISTOR—unijunction
18	1	1	707377	RESISTOR—(100—OHM-1/2 watt)
19	1	1	710768	RESISTOR—(16K—OHM-1/2 watt)
20	1	1	793988	RELAY—start disconnect (repl. 707375)
21	1	1	711483	CAPACITOR—(100 mfb 15V—DC)
22	1	1	710765	RESISTOR—(200—OHM-1/2 watt)
23	1	1	793989	RELAY—engine stop (repl. 707376)
24	1	1	710762	FUSE—5 amp.
25	2	2	710763	CLIP—fuse holder
26	1	1	710759	CAPACITOR—(5 med., 25 volt)
27	1	1	710767	RESISTOR—(27K—OHM-1/2 watt)
28	1	1	710760	CAPACITOR—(1 med., 100 volt)
29	1	1	710769	RESISTOR—(2.7 OHM—1/2 watt)
30	1	1	2000363	RECTIFIER—gate control (8 amp. — 30 volt)
31	1	1	719649	SWITCH—remote, on and off (interior) (repl. 714228)
32	—	1	791805	CONTROL ASSY.—gen. remote (start and stop w/hour meter reading) (eff. w/1975) (w/out ZEO6584)
—	—	1	2014304	CONTROL ASSY.—gen. remote (start and stop w/hour meter reading) (w/ZEO6584)
—	—	1	798397	SWITCH ASSY.—control (w/791805) (SOA)
—	1	1	711484	LABEL—control
—	—	1	798398	WIRE ASSY.—control (5 3/4" length) (w/791805) (SOA)
—	—	1	798399	WIRE ASSY.—control (3 3/4" length) (w/791805) (SOA)
—	—	1	2000362	HARNESS ASSY.—wiring, control board (w/2000341 control)
—	—	1	3736851	METER ASSY.—hour, motor generator (w/TransMode & RPO KNC) (prior to 1978)
—	—	1	2028734	METER ASSY.—hour, motor generator (w/TransMode & RPO KNC) (1978)
—	—	1	2009110	BRACKET—mounting, motor generator hour (w/TransMode & RPO KNC)

FURNISHINGS

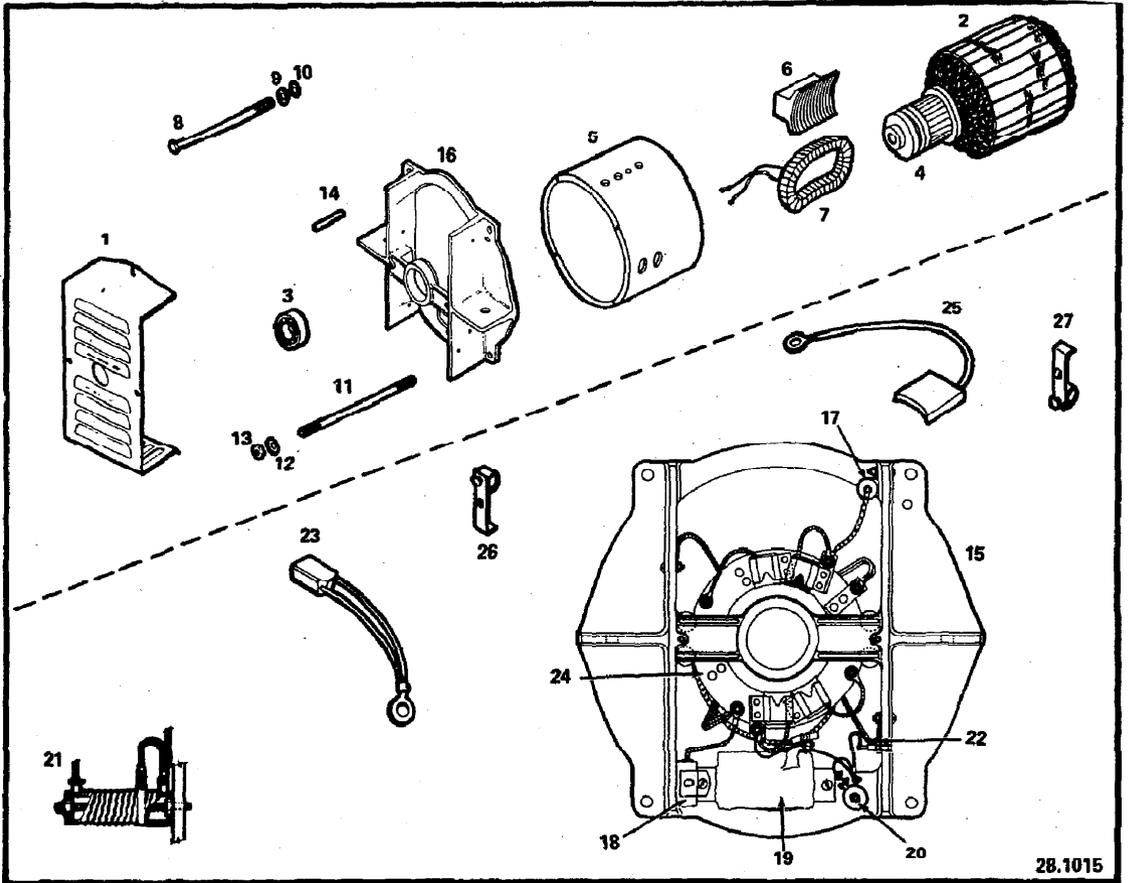

28.1015

28.046 GENERATOR — KOHLER 4KW

FURNISHINGS

KEY 230 260 PART NUMBER

28.046 GENERATOR—KOHLER 4KW

—	1	1	*	NS	GENERATOR ASSY.—Kohler (4KW) (incl. gen. hsg. and engine) (complete) (ref. 708101) (13000B)
1	1	1		708136	COVER—generator end
2	1	1		708105	ARMATURE—assembly
3	1	1	*	NS	BEARING—ball (ref. 708296) (X - 758 - 1)
4	1	1	*	NS	RING—collector (ref. 708297) (237901)
5	1	1		708106	FRAME—generator assembly
6	4	4		708298	POLE—field
7	4	4		708299	COIL—field
8	1	1	*	NS	BOLT—thru (1/2—13 x 10-1/16) (ref. 708137) (237796)
9	1	1		103329	WASHER—lock (1/2)
10	1	1		708138	WASHER—plain
11	4	4		708139	STUD—(5/16—18 x 7-3/4)
12	4	4		103320	WASHER—lock (5/16)
13	4	4		—	NUT—hex (5/16—18) (procure locally) (repl. 124824)
14	1	1		708176	PIN—roll (1/4 O.D. x 5/8)
15	1	1		708107	BRACKET—end assembly
16	1	1		708301	BRACKET—end
17	1	1	*	NS	CONDENSER—(240 volt. AC) (ref. 708302) (232416)
18	1	1		708303	CONDENSER—(100 volt. DC)
19	1	1		708304	ANTI—FLICKER—or cycle compensator
20	1	1	*	NS	RESISTOR—(4 OHM) (ref. 708305) (242088)
21	1	1		708306	STUD—resistor, mounting
22	1	1		708272	RECTIFIER—(Diode)
23	4	4	*	NS	BRUSH—DC (ref. 708309) (237906)
24	4	4		718079	RING—brush holder assy. (SOA) (repl. 708300)
25	4	4	*	NS	BRUSH—AC (ref. 708310) (252148)
26	4	4	*	NS	SPRING—brush (DC) (ref. 708140) (237900)
27	4	4	*	NS	SPRING—brush (AC) (ref. 708141) (269516)
—	6	6		—	SCREW—(10—24 x 3/8) (procure locally)
—	8	8		122158	WASHER—lock (10) (repl. 120217)
—	2	2		9421235	SCREW—(3/8—16 x 1-1/2)
—	2	2		—	SCREW—(10—24 x 1/2) (procure locally)
—	2	2		—	NUT—hex (10—24) (procure locally)
—	2	2		708307	WASHER—resistor centering
—	1	1		—	WASHER—lock (No. 10) (procure locally)
—	1	1	*	NS	KIT—No. 14 lead wire and terminals (ref. 708293) (245677)
—	1	1	*	NS	KIT—No. 10 lead wire and terminals (ref. 708294) (245678)
—	1	1	*	NS	KIT—No. 6 lead wire and terminals (ref. 708295) (245679)
—	1	1		714355	STRAP—frame, generator
—	AR	AR		709147	SHIM—center ring brushes
—	1	1		716803	SWITCH—remote on and off (interior)
—	1	1		715810	HARNESS—generator to utility box (incl. receptical)

FURNISHINGS

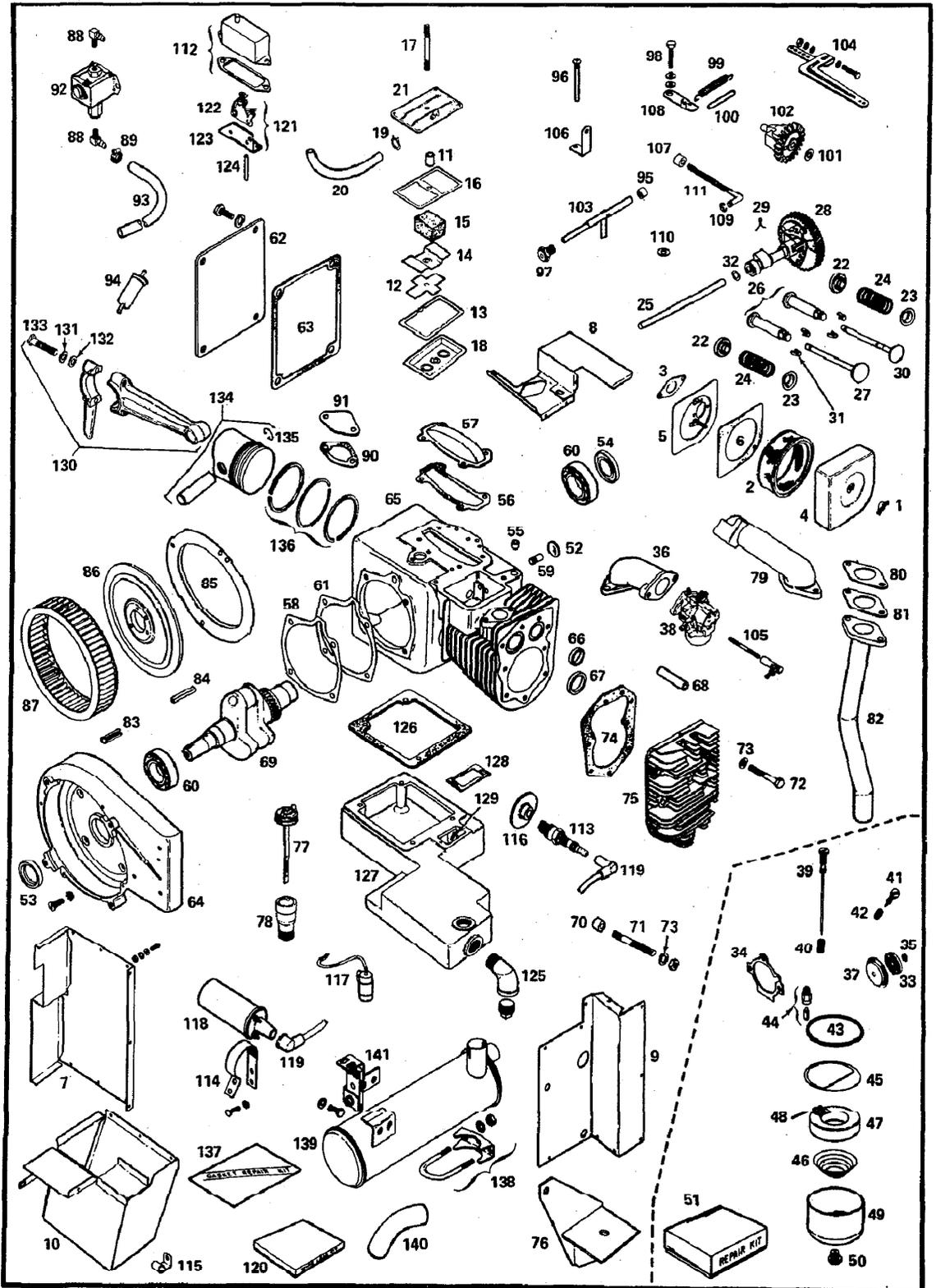

28.046A ENGINE - KOHLER 4KW GENERATOR

28P-1012

FURNISHINGS

KEY	230	260	PART NUMBER
-----	-----	-----	-------------

28.046A ENGINE—KOHLER 4KW GENERATOR

AIR INTAKE

1	1	1	*	708145	NUT—wing (ref. 708145) (X - 276 - 7)
2	1	1		708143	ELEMENT
3	1	1	*	708142	GASKET—air horn (ref. 708142) (275341)
4	1	1	*	708144	COVER—air cleaner (ref. 708144) (45 - 082 - 02)
5	1	1	*	708110	BASE—air cleaner, assembly (ref. 708110) (45 - 201 - 01)
6	1	1	*	708308	GASKET (ref. 708308) (45 - 049 - 01)
—	3	3		—	SCREW—(No. 10—32 x 7/16) (procure locally)
—	3	3		—	WASHER—lock I.T. (No. 10) (procure locally) (repl. 121801)
—	1	1		708146	DECAL—air cleaner

BAFFLES AND SHROUD

7	1	1		708147	COVER—air duct
8	1	1		708148	DUCT—top
9	1	1		708149	AIR DUCT—side
10	1	1		708114	AIR DUCT—chute
—	2	2		120217	WASHER—lock (No. 10)
—	16	16		—	WASHER—lock (No. 10 E.T.) (procure locally) (ref. 138479)
—	1	1		—	WASHER—(1/4) (procure locally)
—	1	1		—	WASHER—(No. 10) (procure locally)
—	17	17		708330	WASHER—plain
—	16	16		159908	SCREW—(No. 10—24 x 3/8)
—	2	2		—	SCREW—(No. 10—24 x 3/8) (procure locally)
—	1	1		9419004	SCREW—serts (1/4—20 x 3/4)

BREATHER AND VENT

11	1	1	*	708154	SEAL—breather (ref. 708154) (231032)
12	1	1	*	708158	REED—breather (ref. 708158) (235047)
13	1	1	*	708159	GASKET—valve cover (ref. 708159) (235048)
14	1	1		708157	BAFFLE—breather
15	1	1	*	708156	FILTER—breather (ref. 708156) (235118)
16	1	1	*	708155	GASKET (ref. 708155) (275144)
17	1	1		708150	STUD—valve cover
18	1	1		708160	PLATE—breather
19	2	2		708152	CLAMP—hose
20	1	1		708153	HOSE
21	1	1		708151	COVER—valve
—	1	1		103319	WASHER—split (1/4)
—	1	1		—	NUT—hex (1/4—20) (procure locally)

CAMSHAFT AND VALVES

22	2	2	*	708238	ROTATOR (ref. 708238) (230020)
23	2	2	*	708240	RETAINER—spring, upper (ref. 708240) (235011)
24	2	2	*	708239	SPRING—valve (ref. 708239) (235168)
25	1	1		708244	PIN—camshaft
26	2	2	*	708220	TAPPET ASSY.— (ref. 708220) (D - 235327)
27	1	1	*	708241	VALVE—intake (ref. 708241) (235582)
28	1	1		715816	CAMSHAFT ASSY.—(repl. 708212)
29	1	1	*	715817	SPRING—actuating (repl. 708255) (ref. 715817) (47 - 089 - 01)
30	1	1		708242	VALVE—exhaust
31	4	4	*	708243	KEEPER—valve (ref. 708243) (240013)
32	AR	AR	*	708245	SPACER—camshaft, .005 (ref. 708245) (275066)
—	AR	AR	*	708246	SPACER—camshaft, .010 (ref. 708246) (275067)

CARBURETOR

33	1	1		716115	SPRING—thermostat (rep. 708313)
34	2	2	*	708314	GASKET—carburetor (ref. 708314) (271030)
35	1	1	*	708315	RING—grip (ref. 708315) (31 - 080 - 01)

FURNISHINGS

KEY 230 260 PART NUMBER

28.046A ENGINE—KOHLER 4KW GENERATOR (Cont.)

36	1	1		708161	ADAPTER—carburetor
37	1	1	*	NS	CUP—choke (ref. 708316) (45 - 109 - 01)
38	1	1	*	NS	CARBURETOR ASSY. (ref. 708111) (200443)
39	1	1	*	NS	NEEDLE—main fuel (ref. 708317) (235415)
40	1	1	*	NS	SPRING—main needle (ref. 708318) (200338)
41	1	1	*	NS	NEEDLE—idle fuel (235006)
42	1	1	*	NS	SPRING—idle needle (ref. 708320) (200380)
43	1	1	*	NS	GASKET—bowl (ref. 708321) (200375)
44	1	1	*	NS	NEEDLE AND SEAT—(SOA)
45	1	1	*	NS	GASKET—baffle (ref. 708322) (200439)
46	1	1		708323	SPRING—float damper
47	1	1	*	NS	FLOAT—(SOA) (ref. 708312) (200408)
48	1	1	*	NS	PIN—float (ref. 708324) (200376)
49	1	1	*	NS	BOWL—fuel (ref. 708325) (235448)
50	1	1		708326	NUT—bowl retaining
51	1	1	*	NS	KIT—carburetor (ref. 708327) (231555)
—	2	2		9418918	SCREW—(5/16—18 x 1)
—	2	2		—	WASHER—lock (5/16) (procure locally)
—	2	2		9416090	SCREW—(No. 6—32 x 3/4)
—	1	1		708127	ELBOW—hose
—	AR	AR		708125	CLAMP—hose
—	2	2		9430677	SCREW—carburetor (hex head 5/16—18 x 1) (300M)

CRANKCASE

52	1	1	*	NS	PLUG (ref. 708230) (X - 230 - 11)
53	1	1	*	NS	SEAL—front oil (ref. 708221) (X - 271 - 30)
54	1	1	*	NS	SEAL—rear oil (repl. 708227)(ref. 709576) (X - 379 - 9)
55	1	1		708228	BEARING—needle
56	1	1	*	NS	GASKET—cover (ref. 708231) (235025)
57	1	1		708232	COVER—camshaft
58	AR	AR	*	NS	GASKET fan housing (ref. 708223) (235070)
59	1	1	*	NS	SHAFT—governor (ref. 708229) (2351255)
60	2	2	*	NS	BEARING—ball (ref. 708225) (235376)
61	1	1	*	708 NS	GASKET (ref. 708224) (235757)
62	1	1		708234	PLATE—closure
63	1	1	*	NS	GASKET (ref. 708233) (45 - 041 - 01)
64	1	1		708222	HOUSING—fan
65	1	1	*	NS	SHORT BLOCK ASSY.—(incl. crankshaft, piston, rings, camshaft, valves, fan housing, bearings and breaker assembly) (ref. 708102) (45 - 522 - 02)
66	2	2		708235	INSERT—exhaust valve
67	1	1		708236	INSERT—intake valve
68	2	2	*	NS	GUIDE—valve (ref. 708237) (235007 - S)
—	4	4		—	WASHER—E.T. (3/8) (procure locally) (ref. 138489)
—	4	4		—	SCREW—(3/8—16 x 1) (procure locally)
—	4	4		9419000	SCREW—(1/4—20 x 1/2)
—	6	6		—	SCREW—(3/8—16 x 1) (procure locally)
—	1	1		712894	WASHER—c/case grp.
—	2	2		9420462	SCREW—c/case grp. (3/8—16 x 1-1/4) (300M)
—	2	2		708123	CLAMP—c/case grp.

CRANKSHAFT

69	1	1	*	NS	CRANKSHAFT (ref. 708226) (45 - 014 - 07)
----	---	---	---	-----------	--

CYLINDER HEAD

70	2	2		708168	SPACER
71	2	2		708167	STUD
72	8	8		9421235	SCREW—H.C. (3/8—16)
73	10	10		708165	WASHER
74	1	1	*	NS	GASKET—head (ref. 708162)
75	1	1	*	NS	HEAD—cylinder (ref. 708163) (45 - 015 - 03)
76	1	1	*	NS	SUPPORT—front mounting (ref. 708166) (45 - 161 - 01)
—	2	2		103321	WASHER—split (3/8) (repl. 131099)
—	4	4		NS	NUT—hex (3/8—16) (ref. 124829)

FURNISHINGS

KEY 230 260 PART NUMBER

28.046A ENGINE—KOHLER 4KW GENERATOR (Cont.)

DIPSTICK

77	1	1	*	NS	DIPSTICK (ref. 708169) (45 - 272 - 01)
78	1	1		708170	TUBE—oil fill

EXHAUST

79	1	1	*	NS	ELBOW—exhaust (ref. 708171) (45 - 054 - 02)
80	1	1		708173	GASKET—exhaust
81	1	1		708174	GASKET—exhaust
82	1	1	*	NS	TUBE—exhaust (ref. 708172) (45 - 123 - 03)
—	1	1		—	SCREW—(5/16—18 x 2-1/4) (procure locally)
—	1	1		—	SCREW—(5/16—18 x 1-5/8) (procure locally)
—	4	4		103320	WASHER—(5/16)
—	2	2		—	SCREW—(5/16—18 x 3/4) (procure locally)

FLYWHEEL

83	1	1	*	708176	PIN—1/4 roll
84	1	1	*	NS	KEY (ref. 708177) (X - 286 - 15)
85	1	1		708175	BAFFLE—air
86	1	1		708178	ADAPTER—rotor
87	1	1		708179	ROTOR
—	7	7		120217	WASHER—split (No. 10)
—	7	7		708332	WASHER—flat
—	7	7		—	SCREW—(No. 10 x 3/8) (procure locally)
—	3	3		9419006	SCREW—sems (1/4—20 x 1)
—	1	1		9419892	WASHER—carb., side baffle (repl. 120392)

FUEL PUMP

88	2	2	*	NS	CONNECTOR—hose (ref. 708127) (X - 391 - 1)
89	AR	AR		708125	CLAMP—hose
90	1	1		708182	GASKET—pump
91	1	1		708183	COVER—pump, pad
92	1	1		712823	PUMP—fuel (repl. 708117)
93	1	1		708180	LINE—fuel (2" long)
94	1	1		708120	FILTER—fuel (ref. 708120) (45 - 050 - 01)
—	1	1		—	WASHER—I.T. No. 8 (procure locally)
—	1	1		—	NUT—hex (8.32) (procure locally) (repl. 120622)
—	1	1		9419000	SCREW—sems (1/4—20 x 1/2)
—	1	1		713333	LINE—fuel (4" long) (repl. 709595)
—	1	1		713331	BRACKET—fuel pump
—	AR	AR		708125	CLAMP—fuel hose

GOVERNOR

95	1	1	*	708184	SPACER
96	1	1	*	NS	PIN—stop (ref. 708185) (231355)
97	1	1	*	NS	BUSHING (ref. 708186) (235476)
98	1	1		708187	SCREW—shoulder
99	1	1		708188	SPRING—governor
100	1	1		708189	DAMPER—spring
101	1	1	*	NS	WASHER—thrust (ref. 708190) (237022)
102	1	1		708191	GEAR—governor
103	1	1		708112	SHAFT—cross assembly
104	1	1		708118	LEVER—throttle
105	1	1	*	NS	ROD—throttle (ref. 708192) (45 - 541 - 01)
106	1	1	*	NS	BRACKET—adjusting screw (ref. 708193) (235084)
107	1	1	*	NS	SPACER (ref. 708194) (235085)
108	1	1		708195	BRACKET—speed, control
109	1	1	*	NS	RETAINER—rod (ref. 708196) (235278)
110	1	1		708197	WASHER—tension
111	1	1	*	NS	ROD—control bracket (ref. 708198) (235277)
—	2	2		122158	WASHER—split (No. 10) (repl. 120217)

FURNISHINGS

KEY 230 260 PART NUMBER

28.046A ENGINE—KOHLER 4KW GENERATOR (Cont.)

—	1	1	—	WASHER—flat (copper)
—	4	4	—	NUT—hex (NO. 10—32) (procure locally) (repl. 120614)
—	1	1	—	WASHER—flat
—	1	1	9419006	SCREW—hex (1/4—20 x 1)

IGNITION

112	1	1	708249	COVER—breaker
113	1	1	5613333	PLUG—spark (repl. 708119)
114	1	1	708200	BRACKET—coil (SOA)
115	1	1	708204	CLIP—cable
116	1	1	* NS	GROMMET (ref. 708202) (45 - 313 - 01)
117	1	1	708201	CONDENSER
118	1	1	* NS	COIL (ref. 708199) (237256)
119	1	1	708203	CABLE—spark plug
120	1	1	708293	KIT—No. 14 wire
121	1	1	* NS	BREAKER ASSY.—incl. next two items marked * (SOA) (A - 220474)
122	1	1	* NS	POINTS—breaker
123	1	1	* NS	BRACKET—breaker
124	1	1	* NS	ROD—breaker (ref. 708249) (232535)
—	2	2	159908	SCREW—(No. 10—24 x 3/8)
—	2	2	9419000	SCREW—(1/4—20 x 1/2)
—	1	1	* NS	GASKET—breaker (ref. 708248) (220174)
—	1	1	131014	WASHER—flat
—	1	1	9417273	SCREW—sems (No. 8—32 x 1/4)

OIL PAN

125	1	1	708207	ELBOW—pipe (3/4)
126	1	1	708205	GASKET—oil pan
127	1	1	708206	PAN—oil
128	1	1	* NS	GASKET—oil, level indicator (ref. 708208) (45 - 041 - 05)
129	1	1	* NS	SWITCH—oil, level indicator (ref. 708209) (45 - 099 - 01)
—	4	4	—	SCREW—(5/16—18 x 2-3/4) (procure locally)
—	4	4	103320	WASHER—split (5/16)
—	2	2	121801	WASHER—L.T. (No. 10)
—	2	2	—	SCREW—(No. 10—24 x 1/2) (ref. 159920)
—	1	1	708210	CLIP

PISTON AND ROD

130	1	1	2005351	ROD—connector assy. (standard) (repl. 708213, 714351)
130	1	1	2005352	ROD—connector assy. (.010" undersize) (repl. 708214, 714353)
131	2	2	103321	WASHER—split, C.R.S. (3/8) (repl. 131099)
132	2	2	708256	WASHER—plain (3/8)
133	2	2	* NS	SCREW—connecting rod (ref. 708257) (236611)
134	1	1	* NS	PISTON ASSY.—(standard) (incl. pin and retaining rings) (45 - 074 - 01)
134	1	1	708216	PISTON ASSY.—(.010" oversize)
134	1	1	708217	PISTON ASSY.—(.020" oversize)
134	1	1	708218	PISTON ASSY.—(.030" oversize)
135	2	2	* NS	RING—retaining (ref. 708258) (235811)
136	1	1	* NS	RING SET—standard (ref. 708250) (45 - 108 - 01)
136	1	1	708251	RING SET—.010" oversize
136	1	1	708252	RING SET—.020" oversize
136	1	1	708253	RING SET—.030" oversize
137	1	1	* NS	GASKET SET (ref. 708254) (45 - 004 - 02)
138	2	2	* NS	CLAMP—muffler (ref. 708115) (237548)
139	1	1	708113	MUFFLER
140	1	1	708211	PIPE—tail
141	1	1	* NS	HANGER—muffler (ref. 708116) (45 - 445 - 01)
—	2	2	9419029	SCREW—(5/16—18 x 1/2)
—	3	3	9418967	SCREW—(3/8—16 x 7/8)
—	2	2	103320	WASHER—split (5/16)
—	3	3	103321	WASHER—split (3/8)
—	3	3	120394	WASHER—plain (3/8) (repl. 446363)

FURNISHINGS

KEY 230 260 PART NUMBER

28.046A ENGINE—KOHLER 4KW GENERATOR (Cont.)

— 2 2 NPN SCREWS—sems. (1/4-20 x 3/8)

FURNISHINGS

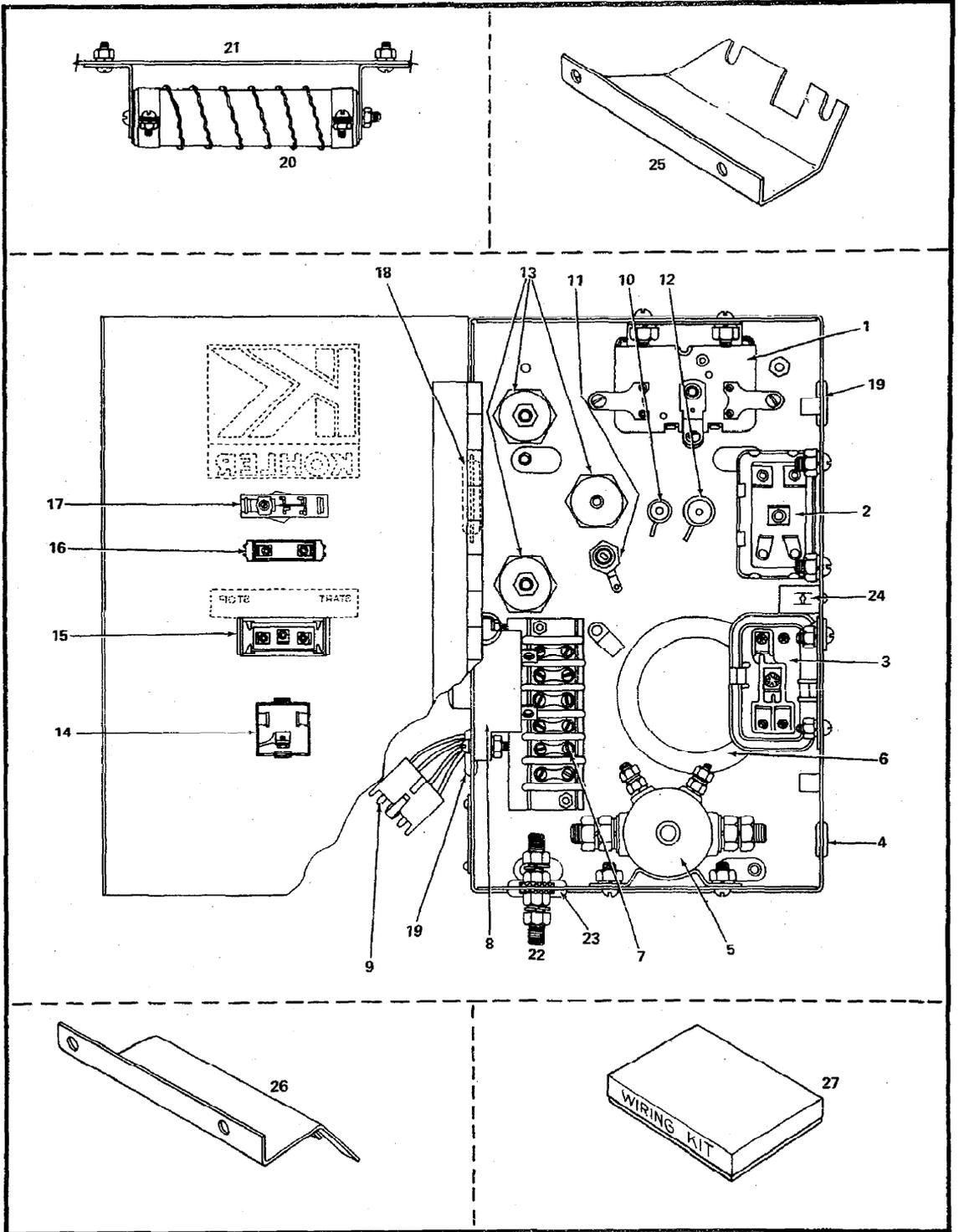

28.046B PANEL - CONTROL, KOHLER 4KW GENERATOR

28P-1013

FURNISHINGS

KEY 230 260 PART NUMBER

28.046B PANEL—CONTROL, KOHLER 4KW GENERATOR

1	1	1	*	NS	RELAY—(R.R.) (ref. 708262) (245269)
2	1	1		708263	RELAY—(2 CR)
3	1	1		708264	RELAY—(1 CR)
4	1	1		708265	GROMMET—controller mounting
5	1	1		715818	RELAY—(C) (repl. 708266)
—	8	8		—	SCREW—relay. (1/4—20 x 1/2 mounting (procure locally)
—	8	8		103319	WASHER—lock, relay mounting (1/4)
—	4	4		—	WASHER—E.T. relay mounting (1/4) (procure locally)
—	8	8		134551	NUT—hex. relay mounting (1/4—20)
6	1	1		713604	GROMMET—controller mounting (repl. 708267)
7	1	1		708268	STRIP—terminal
—	2	2		9417273	SCREW—terminal strip mounting (No. 8—32 x 1/4)
—	2	2		—	WASHER—lock, terminal strip mounting (No. 8) (procure locally)
—	2	2		—	NUT—hex. terminal strip mounting (No. 8—32) (procure locally) (repl. 120622)
8	1	1	*	NS	BREAKER—circuit (ref. 708269) (233713)
—	2	2		—	SCREW—circuit breaker mounting (1/4—20 x 1/2) (procure locally)
—	2	2		103319	WASHER—lock, circuit breaker mounting (1/4)
—	2	2		134551	NUT—hex. circuit breaker mounting (1/4—20)
9	1	1		708261	LEAD ASSY.
10	1	1	*	NS	RESISTOR—50 OHM (R3) (ref. 708270) (243971)
—	1	1		—	SCREW—resistor insulation mounting (No. 8—32 x 1-1/2) (procure locally)
—	1	1		—	WASHER—flat, resistor insulation mounting (No. 8) (procure locally)
—	1	1		—	WASHER—lock, resistor insulation mounting (No. 8) (repl. 121841) (ref. 138530) (procure locally)
—	1	1		120622	NUT—hex. resistor insulation mounting (No. 8—32)
11	1	1		708272	RECTIFIER
12	1	1	*	NS	RESISTOR—15 OHM (R2) (ref. 708273) (X - 474 - 4)
—	2	2		708274	WASHER—resistor centering mounting (No. 10)
—	1	1		—	SCREW—resistor mounting (No. 10—32 x 2-1/2) (procure locally)
—	1	1		9421089	WASHER—flat, resistor mounting (No. 10) (repl. 120391) (procure locally)
—	1	1		122158	WASHER—lock, resistor mounting (No. 10) (repl. 120217)
—	1	1		—	NUT—hex. resistor mounting (No. 10—32) (procure locally) (repl. 120614)
13	3	3		708275	INSULATOR
—	1	1		708276	STUD—insulator mounting (1/4)
—	2	2		—	NUT—hex. insulator jam mounting (1/4—20) (procure locally)
—	2	2		103319	WASHER—lock, insulator mounting (1/4)
—	1	1		708334	WASHER—flat, insulator mounting (1/4)
—	1	1		—	SCREW—insulator mounting (1/4—20 x 3/8) (procure locally)
14	1	1		708277	RECEPTACLE
15	1	1	*	NS	SWITCH—rocker (ref. 708278) (233691)
—	1	1		708279	DECAL—instruction
16	1	1		708280	LIGHT—indicator
17	1	1	*	NS	SWITCH—thermal (ITS) (ref. 708281) (245803)
—	1	1		708282	DECAL—instruction
18	1	1		708283	GROMMET—controller mounting
19	2	2		708284	GROMMET—controller mounting
20	1	1	*	NS	RESISTOR—2 5 OHM (1R2) (ref. 708285) (245442)
—	2	2		708286	WASHER—resistor centering mounting (No. 10)
—	1	1		708335	SCREW—resistor mounting (No. 10—24 x 4-1/2)
—	3	3		120217	WASHER—resistor mounting (No. 10)
—	3	3		—	NUT—hex. resistor mounting (No. 10—24) (procure locally)
—	2	2		—	SCREW—resistor mounting (No. 10—24 x 3/8) (procure locally)
21	1	1		708287	BRACKET—resistor
—	2	2		—	SCREW—resistor bracket mounting (No. 10—24 x 3/8) (procure locally)
—	2	2		120217	WASHER—resistor bracket mounting (No. 10, lock)
—	2	2		120361	NUT—hex. resistor bracket mounting (No. 10—24)
22	1	1		708288	STUD—ground
—	2	2		—	WASHER—E.T. ground stud mounting (1/4) (procure locally)
—	2	2		103319	WASHER—lock, ground stud mounting (1/4)
—	4	4		134551	NUT—hex. ground stud mounting (No. 1/4—20)
23	1	1		794237	GROMMET—controller mounting (repl. 708289)
24	1	1	*	NS	BRACKET—cover (ref. 708290) (265348)
—	1	1		—	SCREW—sheet metal cover bracket mounting (No. 8 x 1/2) (procure locally)
25	1	1		708291	BRACKET—controller mounting, top
—	2	2		9419000	SCREW—controller bracket mounting (1/4—20 x 1/2)

FURNISHINGS

KEY 230 260 PART NUMBER

28.046B PANEL—CONTROL, KOHLER 4KW GENERATOR (Cont.)

—	2	2	103319	WASHER—controller bracket mounting (1/4, lock)
—	2	2	—	SCREW—sems controller bracket mounting (1/4—20 x 5/8) (procure locally) (ref. 179793)
26	1	1	708292	BRACKET—controller mounting, bottom
—	2	2	9419000	SCREW—controller bracket mounting (1/4—20 x 1/2)
—	2	2	103319	WASHER—lock, controller bracket mounting (1/4)
—	2	2	179793	SCREW—sems controller bracket mounting (1/4—20 x 5/8)
27	1	1	708293	KIT—No. 14 lead wire and terminals
—	1	1	708294	KIT—No. 10 lead wire and terminals
—	1	1	708295	KIT—No. 6 lead wire and terminals
—	1	1	714354	BRACKET—controller resistor mtg.
—	1	1	9419892	WASHER—(9/32 I.D. 5/8 O.D.)
—	1	1	794236	STRAP—wire

FURNISHINGS

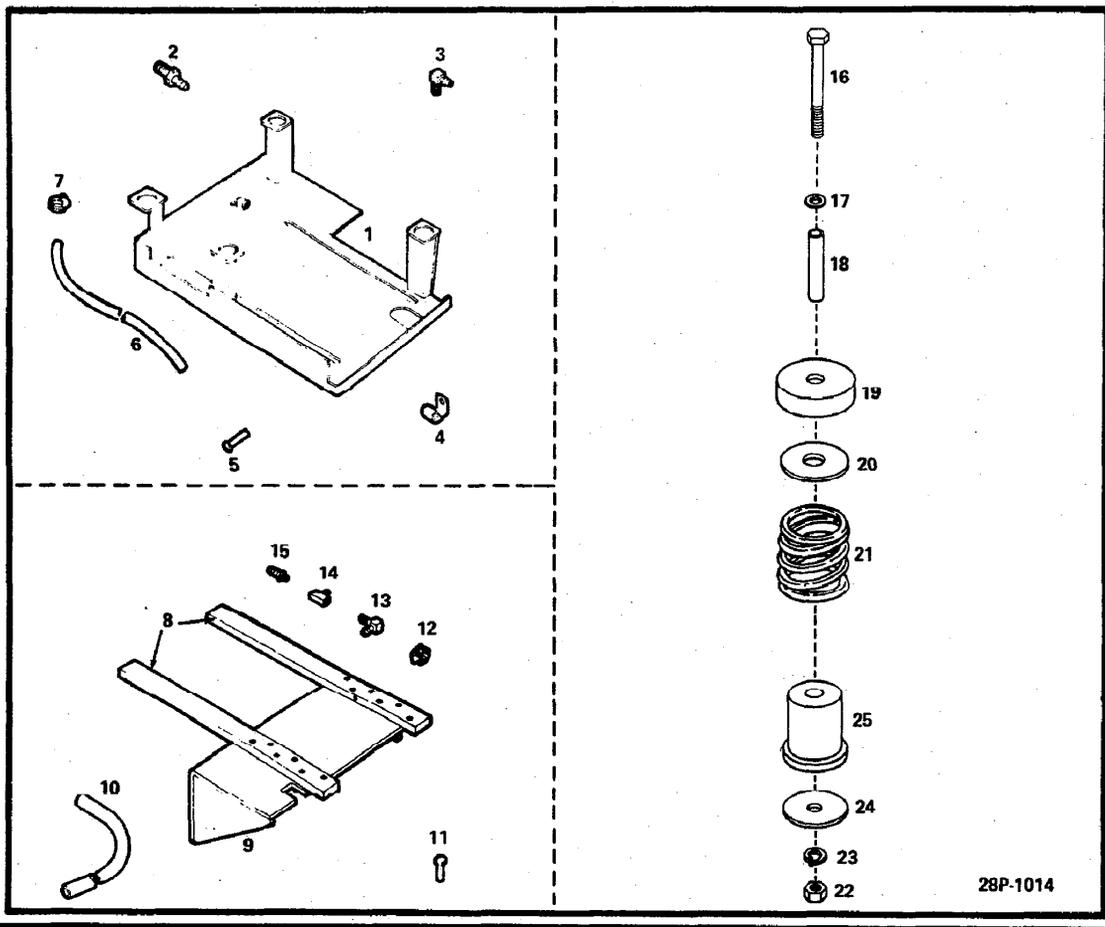

28P-1014

KEY 230 260 PART NUMBER

28.046C KOHLER 4KW GENERATOR MOUNTING

1	1	1	708103	SKID—mounting
2	1	1	708122	CONNECTOR—hose (repl. 708122)
3	1	1	708122	ELBOW—fuel fitting
4	2	2	708123	CLAMP—retaining
5	2	2	159582	SCREW—(8—32 x 5/16)
6	1	1	713332	LINE—fuel (25—1/2" long) (repl. 708124)
7	2	2	708125	CLAMP—hose
8	2	2	NS	BAR—slide (ref. 708129) (45 - 197 - 01)
9	1	1	NS	BRACKET—mounting (ref. 708130) (45 - 126 - 01)
10	2	2	708126	LINE—fuel (10—1/2" long)
11	6	6	—	SCREW—sems, (3/8—16 x 1) (procure locally)
12	1	1	708125	CLAMP—hose
13	1	1	708127	ELBOW
14	1	1	708128	TEE
15	1	1	708121	CONNECTOR—hose
16	1	1	—	SCREW—mounting (4" long) (hex head 3/8—16 x 3/4) (procure locally)
17	4	4	120395	WASHER—plain
18	2	2	708131	SPACER—generator end
19	4	4	708133	CUP—rubber
20	4	4	708328	WASHER—upper
21	4	4	708134	SPRING—mounting
22	4	4	NS	NUT—mounting screw (ref. 124829)
23	4	4	103321	WASHER—lock
24	4	4	708329	WASHER—lower
25	4	4	NS	TEE—rubber mounting (ref. 708135) (237451)
—	2	2	—	WASHER—clamp screw (repl. 121841) (ref. 138530) (procure locally)
—	3	3	9419065	SCREW—mounting (3—3/4" long)
—	2	2	708132	SPACER—engine, end
—	1	1	NS	CAPACITOR—mounting (ref. 714350) (237957)

FURNISHINGS

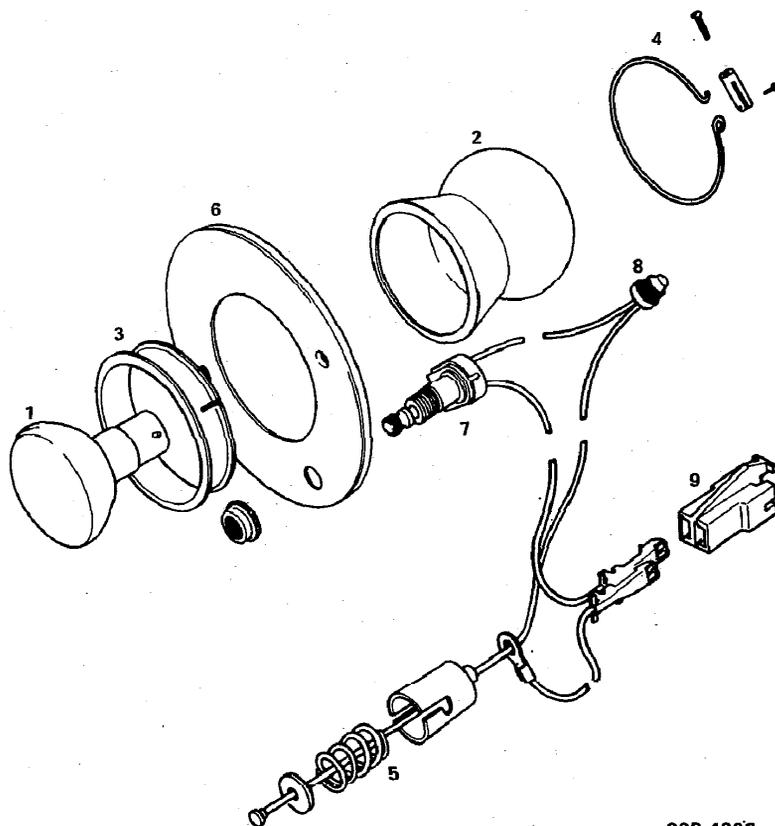

28P-4003

KEY	230	260	PART NUMBER
-----	-----	-----	-------------

28.047 LAMP—READING

—	2	2	705770	LAMP ASSY.—reading, rear (w/out rear cabinet) (prior to 1975)
—	2	2	716804	LAMP ASSY.—reading, rear (w/o bulb) (silver) (prior to 1975)
—	—	2	791703	LAMP ASSY.—reading, rear (complete) (brass) (eff. w/1975) (prior to 1978)
—	—	2	2045152	LAMP ASSY.—reading, rear (gold-finish) (1978) (details not available at time of publication)
1	2	2	9425469	BULB—reading lamp
2	1	1	NS	BALL—lamp housing
3	1	1	NS	RETAINER—ball housing
4	1	1	NS	CLAMP ASSY.—wire, ball
5	1	1	NS	SOCKET ASSY.—bulb
6	1	1	NS	PLATE—trim
7	—	1	793673	SWITCH ASSY.—lamp (incl. gold knob) (w/791703)
8	1	1	NS	CONNECTOR—wire
9	—	1	8911772	CONNECTOR—main-wire
—	—	3	790962	COVER—elec. conduit at overhead cabinet (white plastic) (covers reading lamp wires inside overhead cabinets) (eff. w/1975) (repl. 791842)

FURNISHINGS

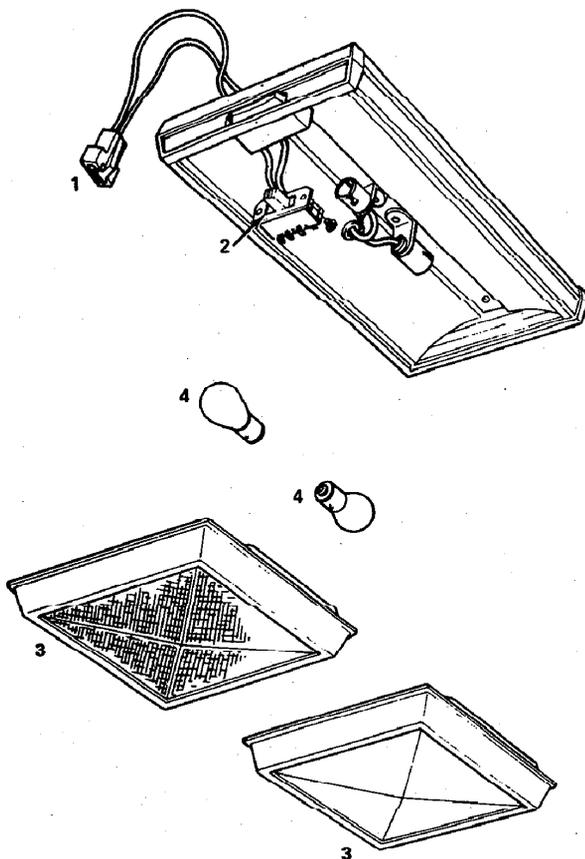

KEY	230	280	PART NUMBER
-----	-----	-----	-------------

28.048 LAMP—HALL & LIVING AREA

—	AR	AR	705453	LAMP ASSY.—overhead (1 bulb) (prior to 1975)
—	AR	AR	705452	LAMP ASSY.—overhead (2 bulb) (prior to 1975)
—	—	1	790379	LAMP ASSY.—overhead (RH dinette cabinet) (eff. w/ 1975) (w/RPO 681, 697) (vehicles built prior to June 21, 1976)
—	—	1	2000974	LAMP ASSY.—overhead (RH/LH) (walnut) (w/RPO 641, 685, 697, 698) (vehicles built after June 21, 1976) (prior to 1978)
—	—	1	2045148	LAMP ASSY.—overhead (RH/LH) (walnut) (w/RPO 641, 697, 698) (1978)
—	—	2	791142	LAMP ASSY.—overhead (hall & LH living area) (eff. w/ 1975) (prior to 1978) (w/RPO 641, 681, 697, or w/ZEO6582, w/ZEO6584)
—	—	1	2045147	LAMP ASSY.—overhead (hall & LH living area) (1978) (RPO 641, 697, 698)
—	—	1	790380	LAMP ASSY.—overhead (galley) (rosewood) (w/RPO 681, 683, 697) (eff. w/ 1975 & vehicles built prior to June 21, 1976)
—	—	2	2006788	LAMP ASSY.—rear overhead cabinet (single lens) (w/ZEO6582) (STD) (SOA)
—	—	1	2006789	LAMP ASSY.—galley (dual lens) (w/ZEO6582) (STD) (SOA)
—	—	1	2000975	LAMP ASSY.—overhead (galley) (eff. w/ 1975) (w/RPO 698)
—	—	1	2000975	LAMP ASSY.—overhead (galley) (walnut) (w/RPO 697) (vehicles built after June 21, 1976) (prior to 1978)

FURNISHINGS

KEY	230	260	PART NUMBER	
-----	-----	-----	-------------	--

28.048 LAMP—HALL & LIVING AREA (Cont.)

—	—	1	2045149	LAMP ASSY.—overhead (galley) (walnut) (w/RPO 641, 697, 698) (1978)
1	—	1	NS	HOUSING—terminal, lamp (ref. 8911772)
2	—	1	798005	SWITCH ASSY.—lamp (w/791142 & 2045147, 2045148, 2045149)
—	—	1	2045967	LENS—lamp (w/2045147, 2045148, 2045149)
3	—	AR	798006	LENS—lamp (w/791142)
3	AR	AR	705482	LENS—overhead lamp (1 and 2 bulb) (prior to 1975)
4	AR	AR	142456	BULB—overhead lamp

FURNISHINGS

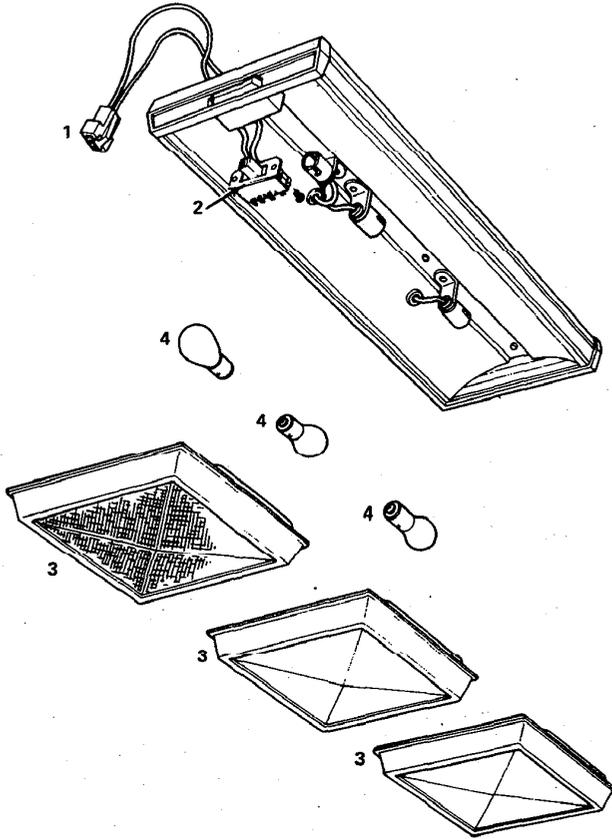

KEY	230	260	PART NUMBER
-----	-----	-----	-------------

28.049 LAMP—BATH

—	2	2	705451	LAMP ASSY.—bathroom (3 bulb) (prior to 1975)
—	—	2	790832	LAMP ASSY.—bathroom (3 bulb) (eff. w/1975) (prior to 1978) (exc/ZEO6582, ZEO6584)
—	—	2	2045146	LAMP ASSY.—bathroom (3 bulb) (1978) (w/ZEO6581)
—	—	1	2006797	LAMP ASSY.—bathroom (recessed overhead) (w/ZEO6582, ZEO6584) (STD) (SOA)
1	—	1	NS	HOUSING—terminal, lamp (ref. 8911772)
2	—	1	798005	SWITCH ASSY.—lamp (w/790832 & 2045146)
—	—	1	2045967	LENS—lamp (w/2045146)
3	—	AR	798006	LENS—lamp (w/790832)
3	2	2	705481	LENS—lamp (w/705451)
4	AR	AR	142456	BULB—overhead lamp

FURNISHINGS

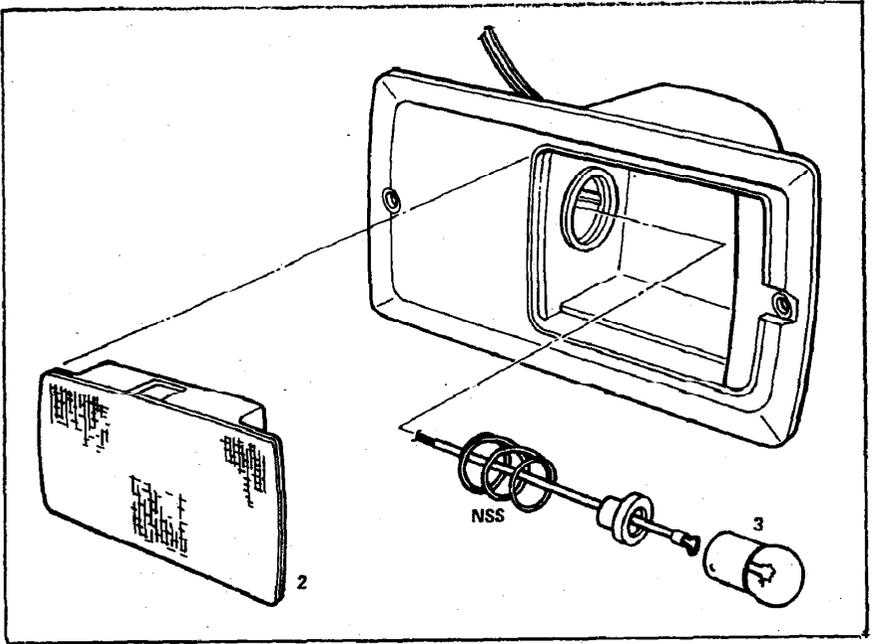

KEY	230	260	PART NUMBER
-----	-----	-----	-------------

28.049A LAMP—FLOOR (AISLE)

—	3	3	715576	LAMP ASSY.—floor, (aisle) (prior to 1975)
1	—	2	791155	LAMP ASSY.—floor, (aisle) (eff. w/1975)
2	—	2	NPN	LENS—lamp (w/791155)
3	—	2	NS	BULB—lamp

FURNISHINGS

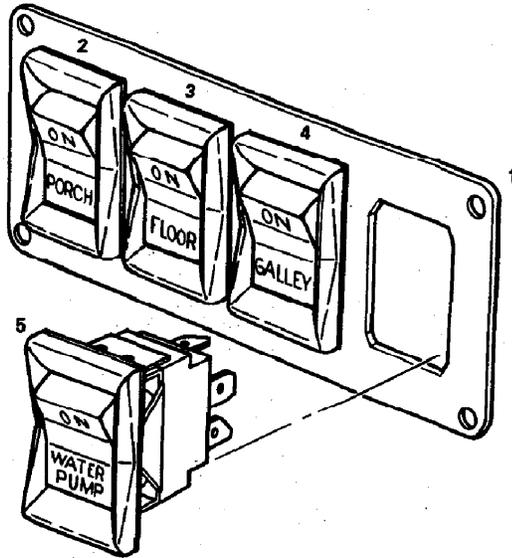

KEY	230	260	PART NUMBER
-----	-----	-----	-------------

28.049B PANEL—SWITCH (LIGHT)

—	3	3	715538	SWITCH—light (aisle, galley, porch) (ivory) (prior to 1975)
—	—	1	790345	PANEL ASSY.—switch, left side (side of refrigerator module) (eff. w/ 1975) (exc./ZEO6582)
—	—	1	2006791	PANEL ASSY.—switch (porch & water pump) (w/ZEO6582) (STD) (details not available at time of publication)
1	—	1	798098	PANEL—mounting. (w/790345)
2	—	1	798093	SWITCH ASSY.—porch (SOA) (w/790345)
3	—	1	798094	SWITCH ASSY.—floor (SOA) (w/790345)
4	—	1	798095	SWITCH ASSY.—galley (SOA) (w/790345)
5	—	1	798096	SWITCH ASSY.—water pump (SOA) (w/790345)

FURNISHINGS

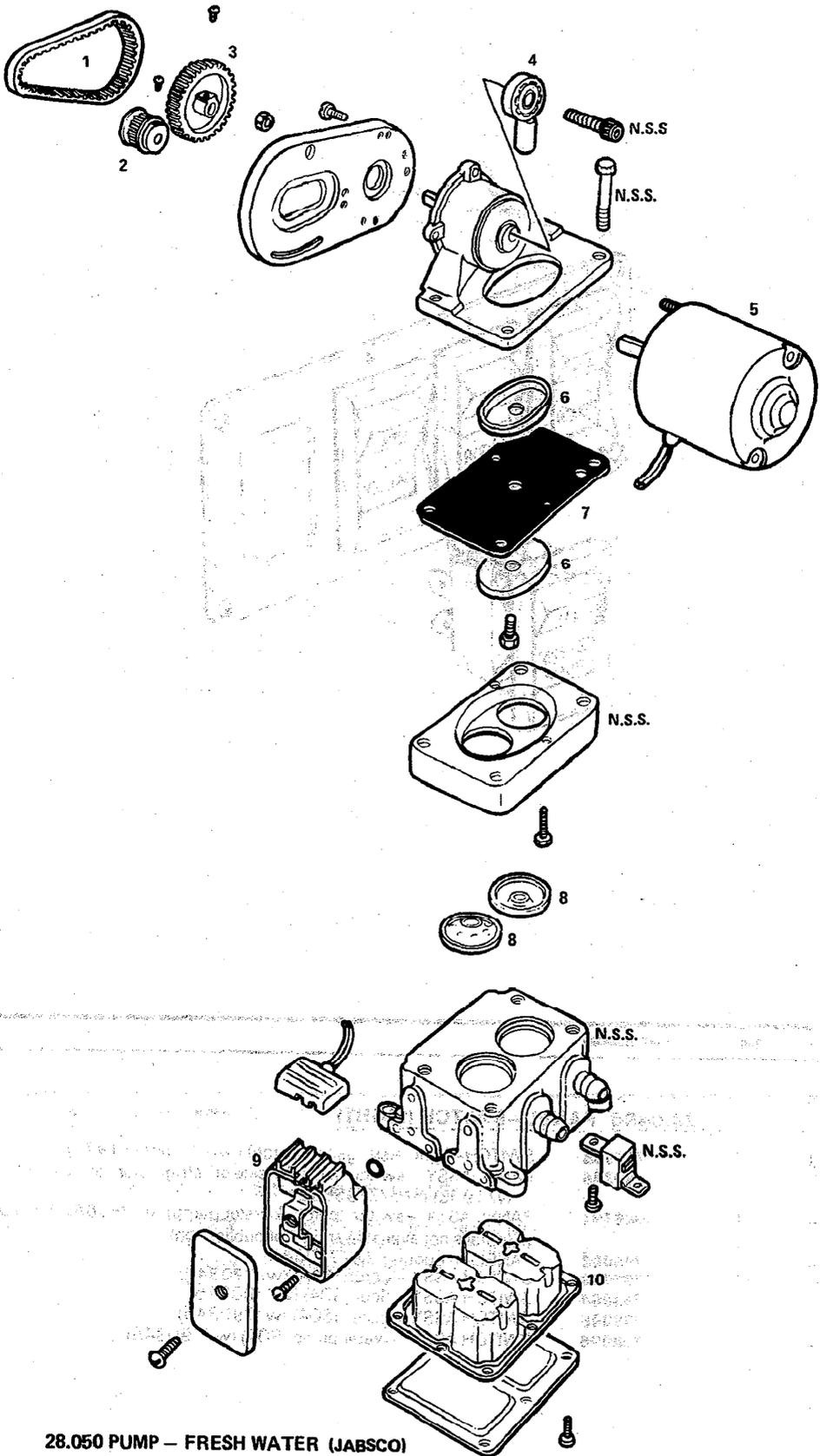

28.050 PUMP - FRESH WATER (JABSCO)
(FIRST DESIGN)

3P-14010

FURNISHINGS

KEY 230 260 PART NUMBER

28.050 PUMP—FRESH WATER (FIRST DESIGN)

—	1	1	705154	PUMP ASSY.—fresh water (complete) (JABSCO) (prior to serial no. 6V102006)
1	1	1	705159	BELT—drive
2	1	1	705157	PULLEY—drive, small
3	1	1	705158	PULLEY—drive, large
4	1	1	705156	ROD ASSY.—connecting
5	1	1	705155	MOTOR
6	2	2	705161	PLATE—diaphragm
7	1	1	705160	DIAPHRAGM
8	1	1	705163	VALVE—intake and discharge (set)
9	1	1	2009958	SWITCH ASSY.—pressure (kit) conversion (SOA) (repl. 705164)
10	1	1	705162	DAMPER ASSY.—pulsation
—	1	1	715538	SWITCH—water pump (located above galley) (ivory)
—	1	1	796778	VALVE—fresh water inlet check (at tank) (repl. 718045)
—	1	1	2034271	PORT SET—inlet and outlet (SOA)
—	—	1	NS	SWITCH ASSY.—(SOA) (w/2009958 switch) (ref. 2010495)
—	—	1	NS	BRACKET—switch mounting (w/2009958 switch) (ref. 2010496)
—	—	1	NS	GASKET—switch (w/2009958 switch) (ref. 2010497)
—	—	1	NS	COVER—switch (w/2009958 switch) (ref. 2010499)

FURNISHINGS

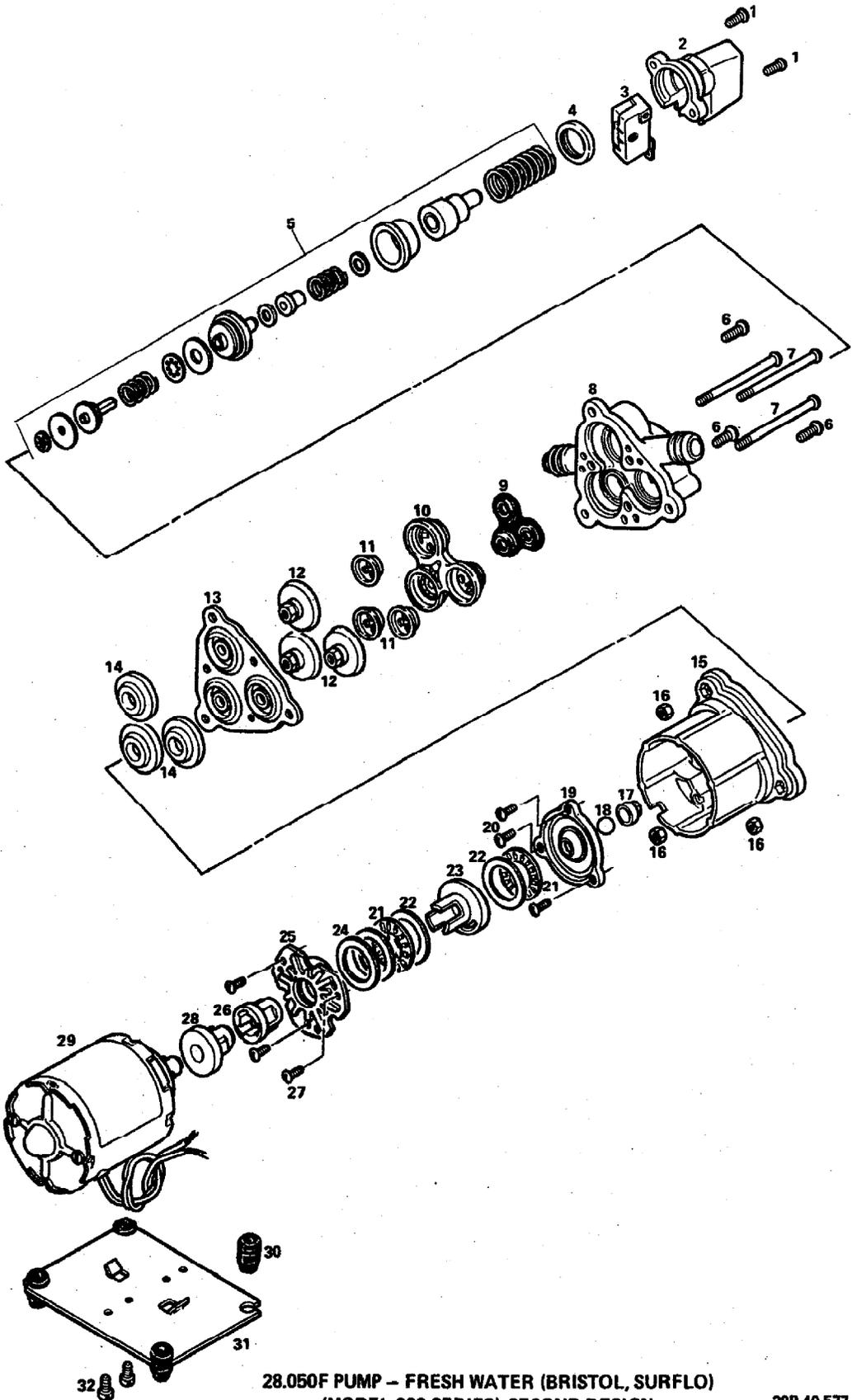

28.050F PUMP - FRESH WATER (BRISTOL, SURFLO)
(MODEL 200 SERIES) SECOND DESIGN

28P-40-577

FURNISHINGS

KEY 230 260 PART NUMBER

28.050F PUMP—FRESH WATER SECOND DESIGN

—	—	1	2006776	PUMP ASSY.—fresh water (bristol. surflo) (eff. w/serial no. 6V102006) (ref. only)
1	—	2	NS	SCREW—water pump
2	—	1	2033370	CAP—switch
3	—	1	2033369	SWITCH ASSY—pump (SOA)
4	—	1	NS	RING—bridge water pump
5	—	1	2033368	MECHANISM ASSY.—switch (SOA)
6	—	3	NS	SCREW—water pump (short)
7	—	3	NS	BOLT—water pump (long)
8	—	1	2033371	HOUSING—upper
9	—	1	2033382	VALVE—discharge (gasket)
10	—	1	NS	VALVE—housing w/screen
11	—	3	2033372	VALVE—(chamber) inlet
12	—	3	2033375	PISTON—top
13	—	1	2033377	DIAPHRAGM—pump
14	—	3	2033376	PISTON—bottom
15	—	1	NS	HOUSING—water pump lower
16	—	3	NS	NUT—hex water pump
17	—	1	NS	BUSHING—water pump
18	—	1	NS	BALL—steel
19	—	1	NS	PLATE—wobble
20	—	3	NS	SCREW—water pump
21	—	2	2001695	BEARING—drive coupling
22	—	4	2033381	WASHER—bearing
23	—	1	NS	COUPLING—drive
24	—	1	NS	SHIM—Mylar
25	—	1	NS	PLATE—support
26	—	1	2033380	BUSHING—drive coupling
27	—	3	NS	SCREW—water pump
28	—	1	NS	COUPLING—water pump
29	—	1	2033367	MOTOR ASSY.—water pump (SOA) (painted black)
30	—	4	2033379	FOOT—base plate
31	—	1	NS	PLATE—base
32	—	2	NS	SCREW—base plate
—	—	1	2033389	KIT HEAD—pump (SOA)

FURNISHINGS

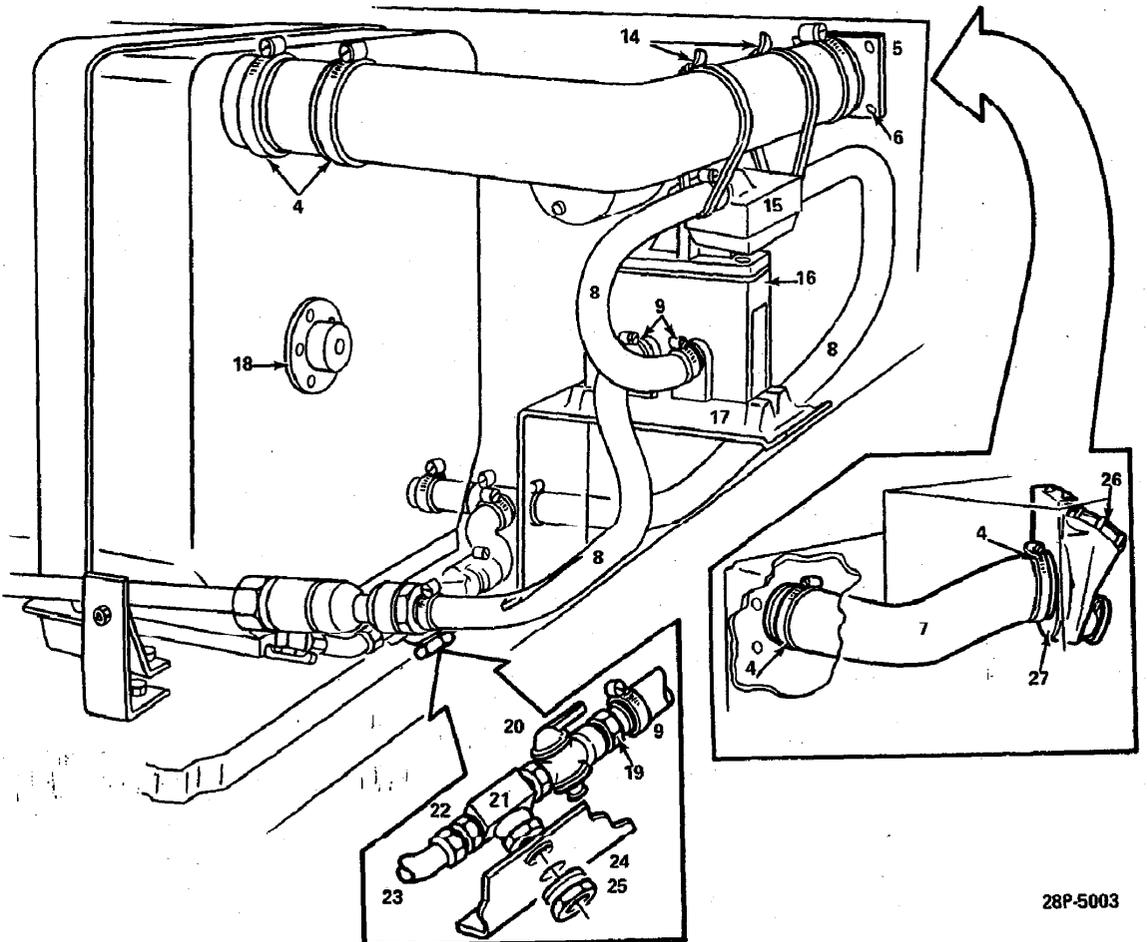
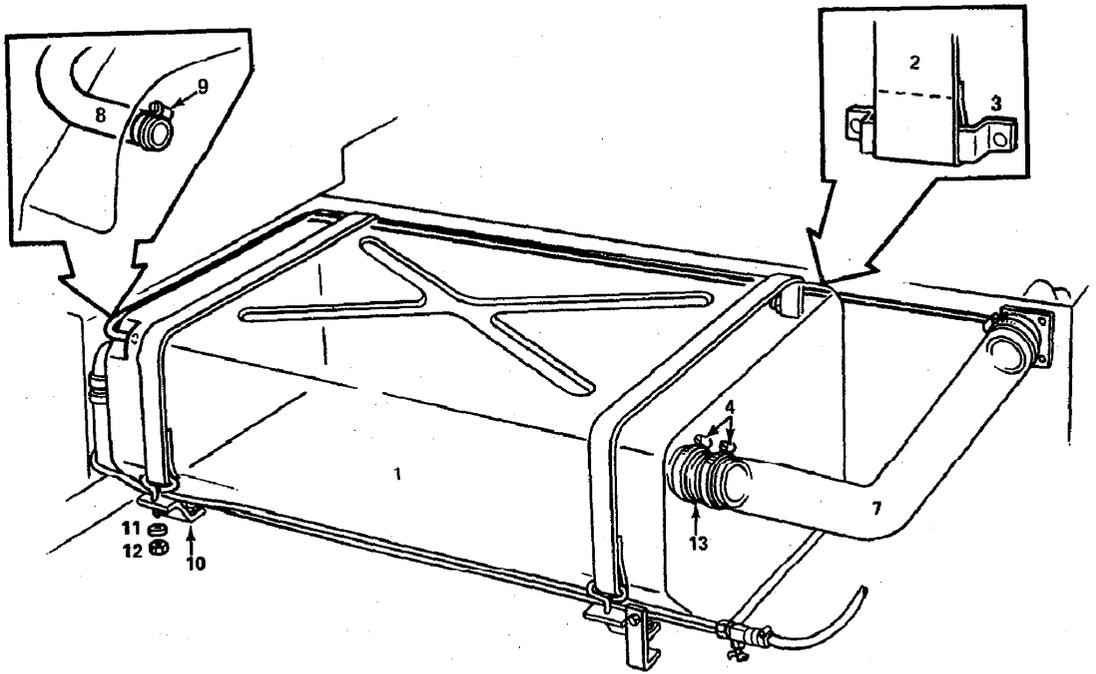

28.051 TANK - FRESH WATER (INCL. FITTINGS)
(FIRST DESIGN)

FURNISHINGS

KEY 230 260 PART NUMBER

28.051 TANK—FRESH WATER (INCL. FITTINGS) (FIRST DESIGN)

1	1	1	2018854	TANK ASSY.—fresh water (w/ZEO6581) (repl. 706126)
NOTE: Sending unit is not part of tank assy. Use 1-6429633 sending unit (incl. gasket). Also use				
1-2001669 TUBE—flexible water fill (90.70" lg. 1 1/4" I.D.) & 1-2001670				
COUPLING—reducer (2" to 1 1/4 insert type) when installing 2018854 fresh water tank.				
2	—	2	791721	STRAP ASSY.—water tank (eff. w/1975)
3	—	2	NS	CLAMP—strap (procure locally)
4	—	5	2465814	CLAMP—water hose (prior to 1975 Second Design)
5	—	1	NS	CONNECTOR ASSY.—fresh water inlet (eff. w/1975) (First Design)(ref. 791067)
5	—	1	791236	GASKET—connector (w/791067)
6	—	4	700368	RIVET—connector
7	—	1	8885531	TUBING—water fill, (RH) from inlet to water tank (2" I.D.) (48" long) (CTL) (First Design) (repl. 790323)
8	—	AR	8885532	TUBING—water tank to water pump and venting system (1/2" I.D.) (25' roll) (CTL) (eff. w/1975) (first design)
9	—	AR	2468869	CLAMP—tube
10	—	2	NPN	ANCHOR—strap, water tank (eff. w/1975) (ref. 791566) (make locally)
11	—	2	9418304	WASHER—bolt, strap anchor
12	—	2	120376	NUT—strap anchor
13	—	1	—	CONNECTOR—outlet, fresh water (prior to 1975 Second Design) (see grp. 28.051A)
—	—	1	2194031	CONNECTOR—fresh water tank outlet (w/ZEO6582, ZEO6584)
14	—	2	676543	STRAP—tube
15	—	1	790334	FILTER ASSY.—water, between water tank and water pump (exc./ZEO6582, ZEO6584) (eff. w/1975) (first design)
16	1	1	—	PUMP ASSY.—fresh water (see group 28.050)
17	—	1	791555	SUPPORT—water pump (eff. w/1975)
18	1	1	6429633	SENDING UNIT—fresh water tank (incl. next item)
18	—	1	6429637	GASKET—sender
19	—	2	2061210	CONNECTOR—bulkhead, water tank (eff. w/1975)
20	—	1	2429626	VALVE—fresh water tank (exc./ZEO6582, ZEO6584)
21	—	1	444134	TEE—hose (1/4—18)
22	—	1	652629	CONNECTOR ASSY.—hose to tee
23	AR	AR	8884956	TUBING—fresh water tank, black nylon, extruded (9/32 I.D.) (25 ft. roll) (CTL)
24	—	1	—	WASHER—tee (3/4") (procure locally)
25	—	1	219758	NUT—(3/4—16)
26	—	1	—	FILLER—water (see group 23.051A)
27	—	1	790088	SUPPORT—inlet (eff. w/1975) (First Design)
—	1	1	2032557	TAG—portable water fill ("warning, potable water only — sanitize, flush and drain before using — see instruction manual") (repl. 791691)
—	1	1	—	INLET ASSY. (valve)—city water (located at utilities compartment) (see group 28.130)
—	—	1	444012	REDUCER—pipe (eff. w/1975)
—	—	1	791659	VALVE ASSY.—water tank vent (eff. w/1975)
—	—	2	793398	ADAPTER ASSY.—hose, at water tank (tee) (barbed male) (eff. w/1975) (First Design)
—	—	1	3745928	BOLT—strap eye (eff. w/1975)
—	—	AR	8860217	WEBBING—tie down (strap) (36.00" per vehicle) (70") (CTL)
—	—	2	795685	TEE ASSY.—water tank, pump and fresh water system drain (1/2" plastic) (repl. 791675) (eff. w/1975) (First Design)
—	—	3	NPN	BRACKET—water tank compartment to floor (eff. w/1975) (make locally)
—	AR	AR	2014028	TUBING—fresh water (1/2 ID x 3/8 OD) (20 ft. straight length)
—	AR	AR	2014030	TUBING—fresh water (3/8 ID x 1/2 OD) (20 ft. straight length)
—	AR	AR	2014031	TUBING—fresh water (1/2 ID x 5/8 OD) (20 ft. straight length)
—	—	1	2001630	PLUMBING KIT—repair (complete) (eff. w/1975) (incl. next three (3) repair kits) (ref. only)
—	—	1	2001631	PLUMBING KIT—repair (3/8) (eff. w/1975)
—	—	1	2001632	PLUMBING KIT—repair (1/2") (eff. w/1975)
—	—	1	2001633	PLUMBING KIT—repair (5/8") (eff. w/1975)
—	—	1	2061210	CONNECTOR—water tank and pump drain bulk head (eff. w/1975)

FURNISHINGS

KEY 230 260 PART NUMBER

28.051 TANK—FRESH WATER (INCL. FITTINGS) (FIRST DESIGN) (Cont.)

—	—	1	444134	TEE—drain, water tank and pump (eff. w/1975) (exc./ZE06582, ZE06584)
—	—	1	2429626	VALVE ASSY.—shut off, water tank & pump drain to tee (eff. w/1975) (exc./ZE06582, ZE06584)
—	—	1	680310	NIPPLE—valve, shut off (eff. w/1975) (first design)
—	—	1	796778	VALVE—water tank vent check
—	—	1	652629	CONNECTOR—tube, water tank & pump drain tee nylon (eff. w/1975)
—	—	1	3838094	NIPPLE—fresh water tank to hot water tank (eff. w/1975) (prior to 1978)
—	—	1	2463052	NIPPLE—fresh water tank to hot water tank (1978)
—	—	1	791166	CLIP—pipe, RH sanitary plumbing
—	—	2	2008017	BRACKET—fresh water tank strap (w/ZE06582, ZE06584)
—	—	1	2006741	TEE—fresh water tank and pump drain (w/ZE06582, ZE06584)
—	—	1	—	HOSE—fresh water drain (ref. 2020199) (Proc. loc.) (1/4" O.D. x .035 copper)
—	—	1	444626	PLUG—fresh water tank (w/ZE06582, ZE06584)

FURNISHINGS

NOTES

FURNISHINGS

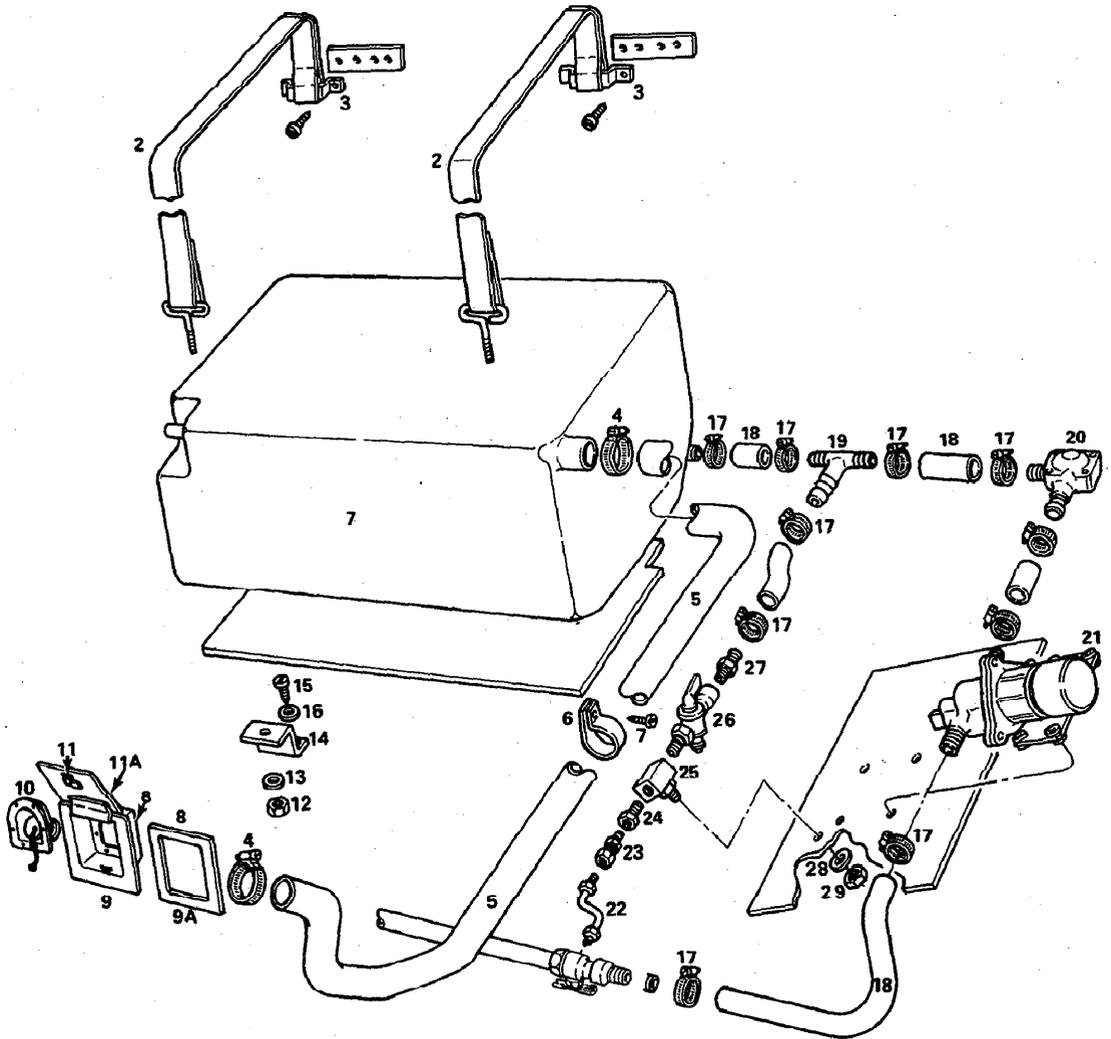

28.051A TANK - FRESH WATER (INCL. FITTINGS)
(SECOND DESIGN)

28P-5004-177

FURNISHINGS

KEY 230 260 PART NUMBER

28.051A TANK—FRESH WATER (INCL. FITTINGS) (SECOND DESIGN)

1 1 1 **2018854** TANK ASSY.—fresh water (w/ZE06581) (repl. 706126)

NOTE: Sending unit is not part of tank assy. Use 1-6429633 sending unit (incl. gasket). Also use
 1-2001669 TUBE—flexible water fill (90.70" lg. 1 1/4" I.D.) & 1-2001670
 COUPLING—reducer (2" to 1 1/4" insert type) when installing 2018854 water ta

1	—	1	2006652	TANK ASSY.—fresh water (w/ZE06582)
1	—	1	2021124	TANK ASSY.—fresh water (w/ZE06584) (repl. 2015299)
2	—	2	791721	STRAP ASSY.—water tank (eff. w/1975)
3	—	2	—	CLAMP—strap (procure locally)
4	—	2	9139804	CLAMP—fresh water hose (eff. w/1975 second design) (repl. 2465813)
5	—	1	2001669	TUBING—water fill. (LH) from inlet to water tank (1.25" I.D.) (90.70" long)
5	—	1	2022110	TUBING—water fill. (LH) from inlet to water tank (1.25" I.D.) (99.00" long)
6	—	3	791156	CLIP ASSY.—tube water fill
7	—	3	11503684	SCREW—tube water fill clip (repl. 9427230)
8	—	1	2005011	SEAL—fresh water fill
9	—	1	2012753	COMPARTMENT ASSY.—fresh water fill
9A	—	1	2012756	COMPARTMENT—fresh water fill
10	—	1	2004698	FILLER ASSY.—fresh water (located at LH side under rear sash) (eff. w/1975 second design)
—	—	1	2033017	CAP ASSY.—filler (SOA) (w/2004698 filler assy.)
11	—	1	9728247	RETAINER—fresh water fill door
11A	—	1	2012754	DOOR—fresh water fill
12	—	4	9417954	NUT—strap anchor
13	—	4	9418304	WASHER—bolt, strap anchor
14	—	2	791566	ANCHOR—strap, water tank (eff. 1975)
15	—	2	NS	SCREW—strap anchor (also use 1-3718496 washer) (ref. 9422176)
16	—	2	9419892	WASHER—strap anchor
17	—	AR	2468869	CLAMP—tube
18	—	AR	2224567	TUBING—water tank to water pump and venting system (1/2" I.D.) (39" lg.) (neoprene)
19	—	1	795685	TEE—water tank, pump and fresh water system drain (1/2" neoprene)
20	—	1	2010322	FILTER ASSY.—water, between water tank and water pump (incl. next (2) items)
—	—	1	2011900	GASKET—filter, fresh water tank (w/2010322 filter assy.)
—	—	1	2014502	SCREEN—filter, fresh water tank (w/2010322 filter assy.)
21	1	1	—	PUMP ASSY.—fresh water (see grp. 28.050)
22	—	AR	8884956	TUBE—water tank & pump drain tee
23	—	1	625629	CONNECTOR—tube, water tank, & pump drain tee (nylon) (eff. w/1975)
24	—	2	2061210	CONNECTOR—water tank, & pump drain tee
25	—	1	444134	TEE—water tank & pump drain (1/4 x 18) (exc./ZE06582, ZE06584)
26	—	1	2429626	VALVE ASSY.—shut off water tank & pump drain (exc./ZE06582, ZE06584)
27	—	1	2194031	NIPPLE—water tank & pump drain
28	—	1	—	WASHER—tee (3/4") (ref. 138056) (procure locally)
29	—	1	219758	NUT—tee washer (3/4 - 16)
—	1	1	6429633	SENDER—fresh water tank
—	—	1	6429637	GASKET—sender
—	—	1	792251	CONNECTOR—outlet, fresh water
—	—	1	2001670	CONNECTOR—fresh water tank outlet (exc./ZE06582, ZE06584)
—	—	1	790839	FILTER ASSY.—tank (incl. screen & "L" shaped connector) (eff. w/1975 & prior to 1976) (w/ZE06582, ZE06584)
—	—	1	2003132	FILTER ASSY.—fresh water tank vent valve (incl. screen & straight connector 3 3/4") (eff. w/1976) (exc./ZE06582, ZE06584)
—	—	1	444040	ADAPTER—faucet to shower
—	—	1	680310	CONNECTOR—fresh water system at drain tee

FURNISHINGS

KEY 230 260 PART NUMBER

28.051B WATER FILL COMPARTMENT (FRESH WATER TANK)

—	—	1	2005124	COMPARTMENT ASSY.—fresh water fill LH (eff. w/ 1975 second design) (prior to interm 1976) (includes next (5) items)
—	—	1	2005010	COMPARTMENT—fresh water fill
—	—	1	2004900	DOOR ASSY.—compartment
—	—	1	2005014	STRIKER—compartment door
—	—	4	700368	RIVET—door & striker to compartment
—	—	4	446161	WASHER—rivet to compartment
—	—	1	—	RETAINER—door lock, fill compartment (ref. 9428247)
—	—	1	2002635	CYLINDER—lock
9	—	1	—	COMPARTMENT ASSY.—fresh water fill (eff. w/interm 1976) (see gr. 28.051A) (incl. next (5) items)
9A	—	1	—	COMPARTMENT—fresh water fill (see gr. 28.051A)
11A	—	1	—	DOOR—fresh water fill (see gr. 28.051A)
—	—	1	703710	HINGE—fresh water fill door
—	—	1	2005014	STRIKER—fresh water fill door
—	—	4	700368	RIVET—fresh water fill

FURNISHINGS

NOTES

FURNISHINGS

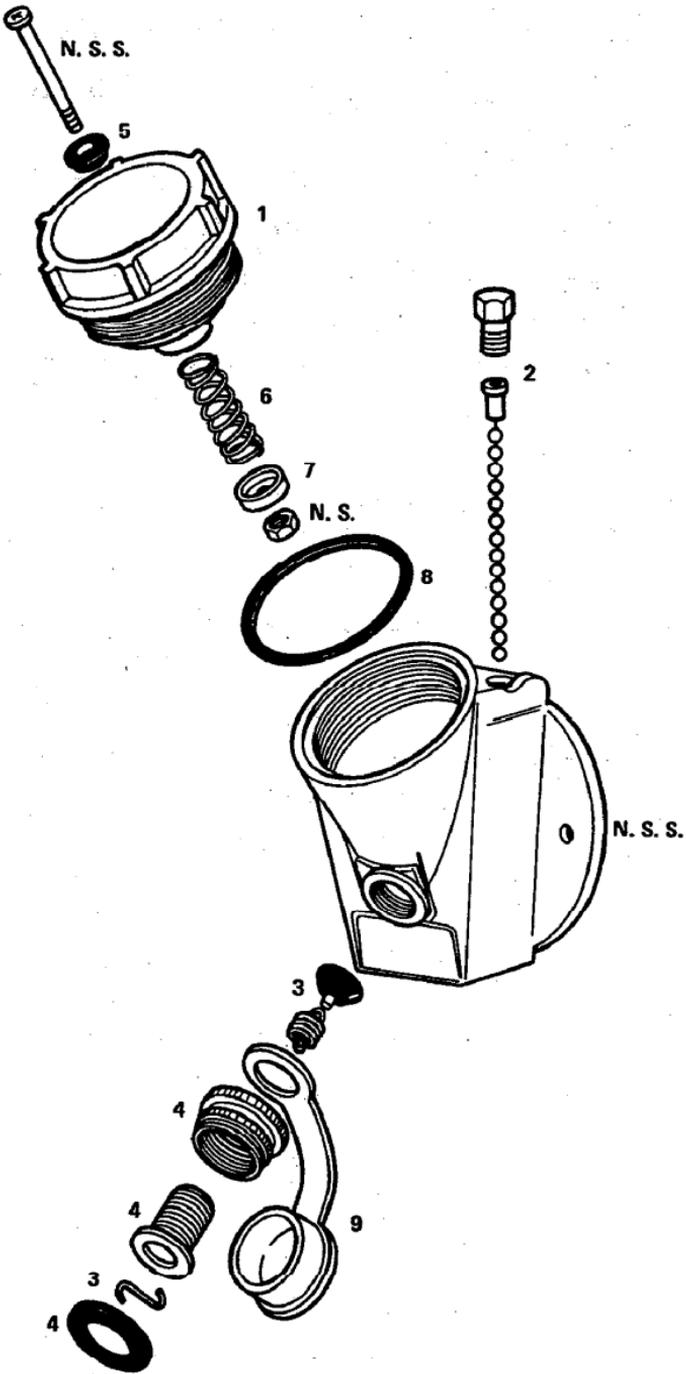

28P-32

28.051A FILLER - WATER

FURNISHINGS

KEY 230 260 PART NUMBER

28.051C FILLER—WATER (FRESH WATER TANK)

—	1	1	715170	CAP ASSY.—fresh water tank (incl. keys) (SOA) (prior to 1975)
—	—	1	791167	FILLER ASSY.—water, at inlet (prior to 1975 First Design)
1	—	1	798007	CAP ASSY.—filler (SOA)
2	—	1	798008	CHAIN ASSY.—cap, (SOA)
3	—	1	798009	KIT—check valve, (incl. check plugs & pin, spring & spring retainer) (SOA)
4	—	1	798010	KIT—water inlet adapter, (incl. hose coupling, adapter & washer) (SOA)
5	—	1	798013	WASHER—cap screw
6	—	1	798014	SPRING—cap
7	—	1	798015	WASHER—spring, cap
8	—	1	798016	O—RING—cap
9	—	1	798017	CAP—dust
—	—	1	2004698	FILLER ASSY.—fresh water (located at LH side under rear sash) (eff. w/ 1975 second second design) (incl. next item) (for illus. see gr. 28.051A item # 10)
—	—	1	2033017	CAP ASSY.—filler (w/ 2004698 filler assy.) (SOA)

FURNISHINGS

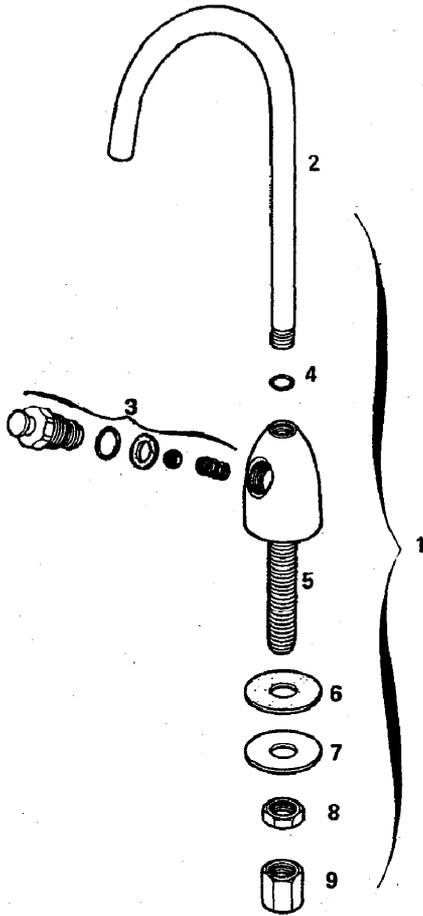

28P-12

KEY 230 280 PART NUMBER

28.052 FAUCET—WATER TREATMENT UNIT

—	1	1	2234649	TREATMENT UNIT—water (kit)
1	1	1	706783	FAUCET ASSY.—water treatment unit (First Design) (ecom system)
2	1	1	710100	SPOUT—faucet swing
3	1	1	706786	KIT—repair, valve stem
4	1	1	NS	"O" RING—spout to body
5	1	1	NS	BODY—valve
6	1	1	NS	GASKET—composition, valve body (ref. 706787)
7	1	1	NS	WASHER—valve body
8	1	1	NS	NUT—locking, valve body
9	1	1	NS	NUT—compression, valve body
—	1	1	710099	TUBING—plastic (1/4" dia. 48" long)

NOTE: See 28.052A Illustration for Balance of Water Treatment Unit

FURNISHINGS

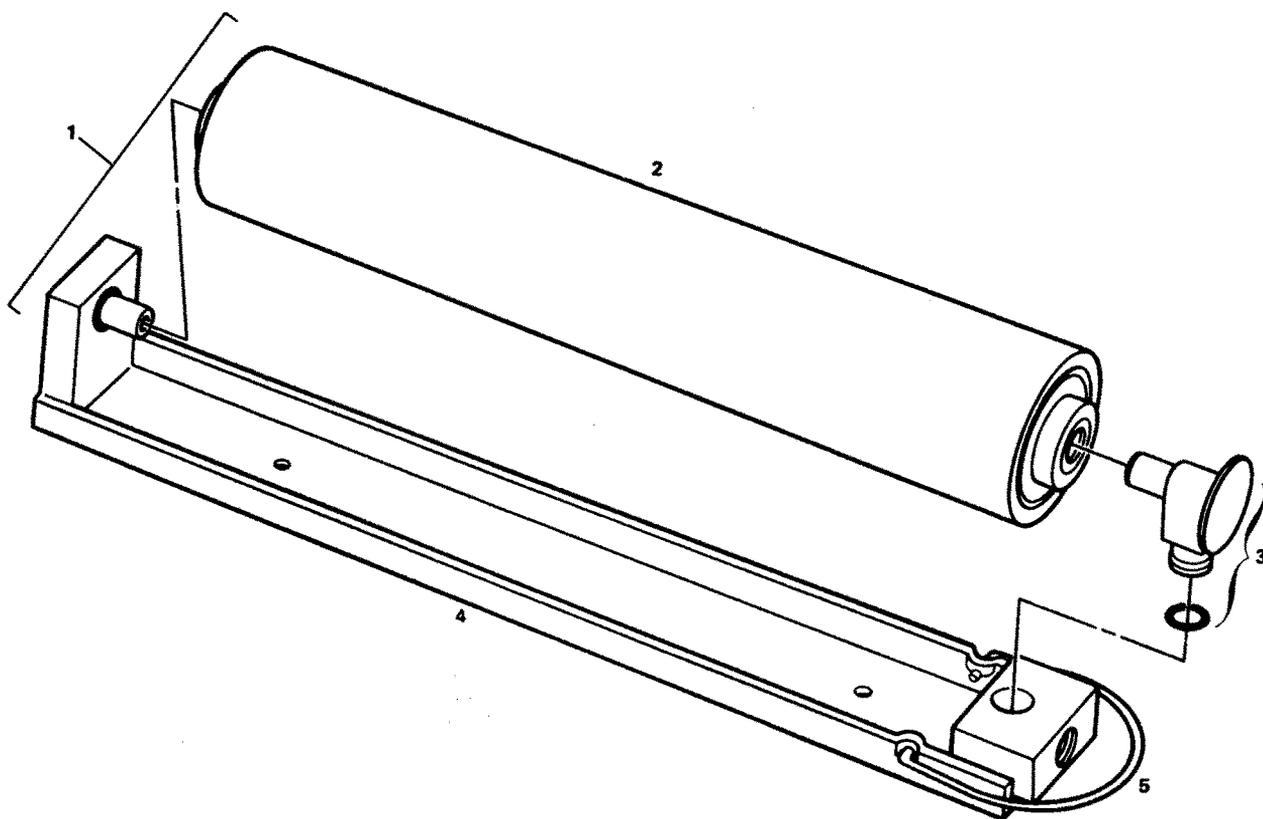

28P-14

KEY	230	260	PART NUMBER
-----	-----	-----	-------------

28.052A CARTRIDGE—WATER TREATMENT UNIT

1	1	1	706782	CARTRIDGE & BRACKET ASSY.—water treatment unit, filter (First Design) (ecom system)
2	1	1	706785	CARTRIDGE—water treatment unit, filter (First Design)
3	1	1	706784	KIT—adapter elbow and "O" ring (SOA) (First Design)
4	1	1	NS	BRACKET—filter frame
5	1	1	NS	BALE—locking, quick release

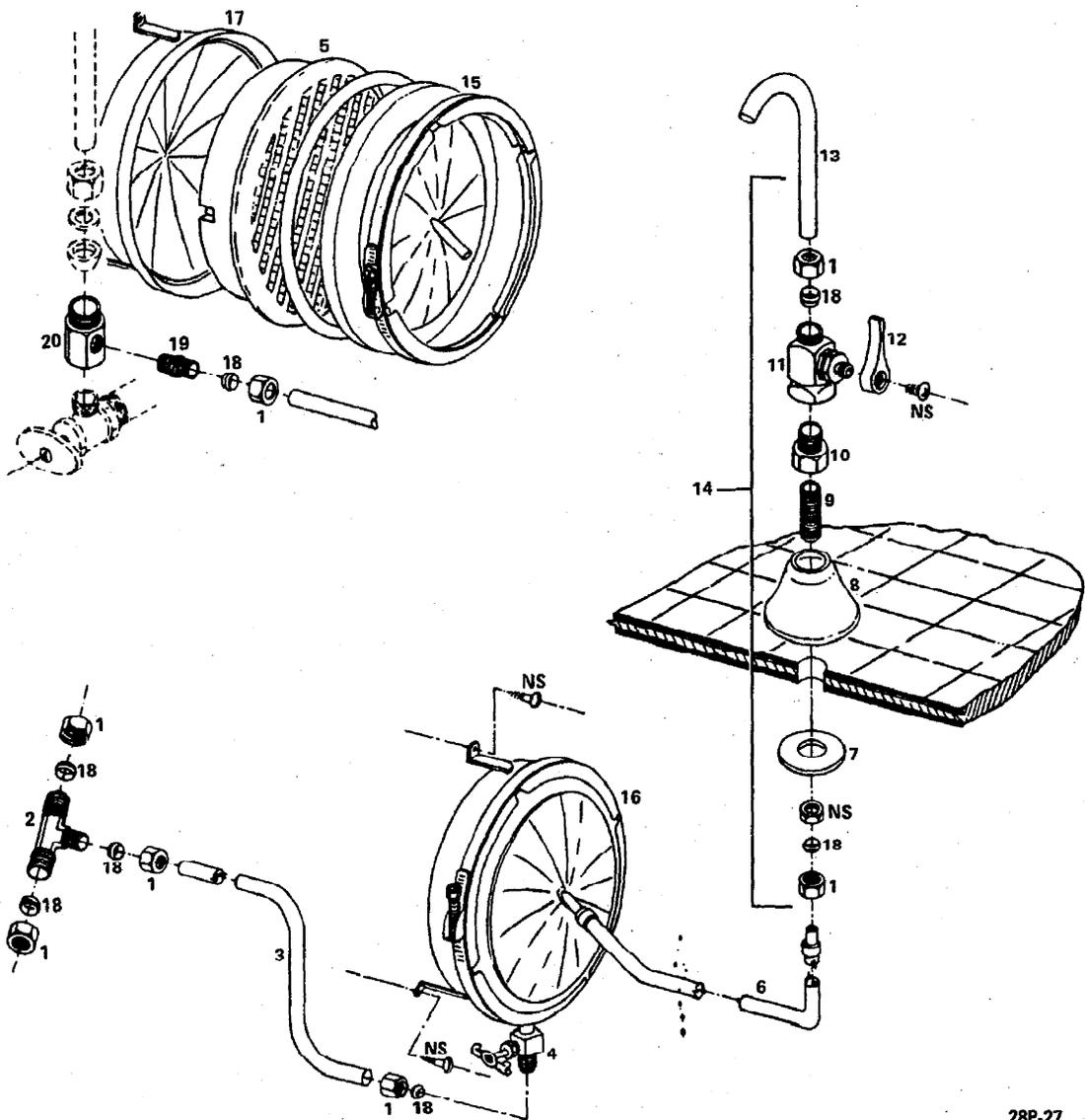

28P-27

28.052B WATER PURIFIER AND FAUCET ASSY

FURNISHINGS

KEY 230 260 PART NUMBER

28.052B WATER TREATMENT UNIT AND FAUCET

—	1	1	719655	TREATMENT UNIT—water (kit) (Second Design) (water gard)
1	7	7	—	NUT—pipe (procure locally)
2	1	1	—	TEE—pipe (procure locally)
3	1	1	—	PIPE—flexible (procure locally)
4	1	1	—	INLET—treatment, cartridge
5	1	1	719658	CARTRIDGE—treatment unit, water (SOA) (Second Design) (water gard)
6	1	1	—	PIPE—outlet, cartridge (procure locally)
7	1	1	NS	WASHER—base, faucet
8	1	1	NS	BODY—valve
9	1	1	NS	SPRING—valve
10	1	1	NS	BOLT—valve
11	1	1	NS	VALVE—faucet
12	1	1	NS	HANDLE—valve
13	1	1	720132	SPOUT—water treatment unit, faucet (water gard)
14	1	1	719657	FAUCET ASSY.—water treatment unit, (Second Design) (water gard) (SOA)
15	1	1	NS	LID—cartridge, treatment unit,
16	1	1	NS	CANISTER ASSY.—cartridge, treatment unit,
17	1	1	NS	COVER—cartridge, treatment unit,
18	7	7	—	SLEEVE—connector (procure locally)
19	1	1	—	CONNECTOR—pipe (procure locally)
20	1	1	—	FITTING—pipe (procure locally)

FURNISHINGS

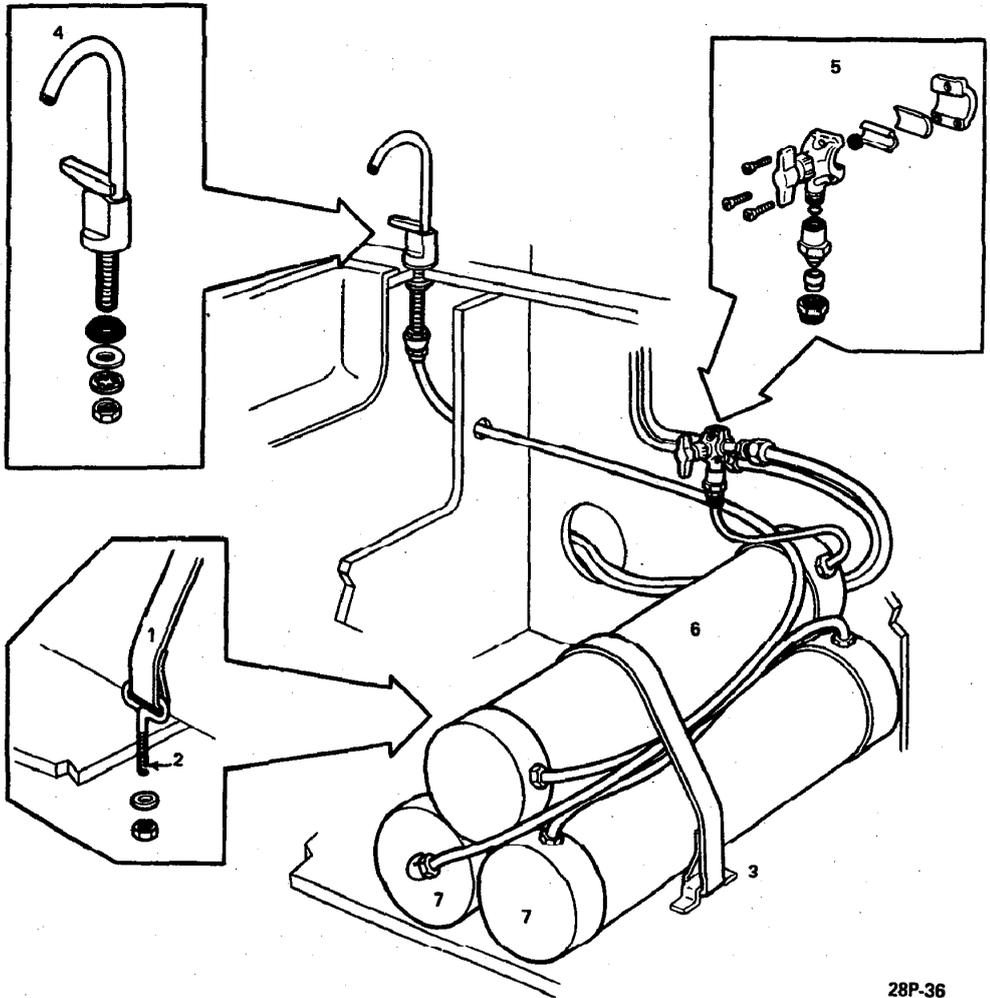

28P-36

KEY	230	260	PART NUMBER
-----	-----	-----	-------------

28.052C TREATMENT UNIT—WATER

—	—	1	2234773	TREATMENT UNIT—water (complete) (repl. 798360) (eff. w/1975)
1	—	1	798682	STRAP ASSY.—treatment unit, to floor
2	—	1	3745928	BOLT—strap eye
—	—	AR	8860217	WEBBING—tie down (2 1.60" per vehicle) (70") (CTL)
3	—	1	—	CLAMP—strap to floor (procure locally) (ref. 2383392)
4	—	1	2002831	FAUCET ASSY.—purifier treatment unit
5	—	1	2002832	VALVE ASSY.—saddle, treatment unit
6	—	1	2002833	CARTRIDGE—replacement
7	—	2	NS	RESERVOIR—water

FURNISHINGS

NOTES

FURNISHINGS

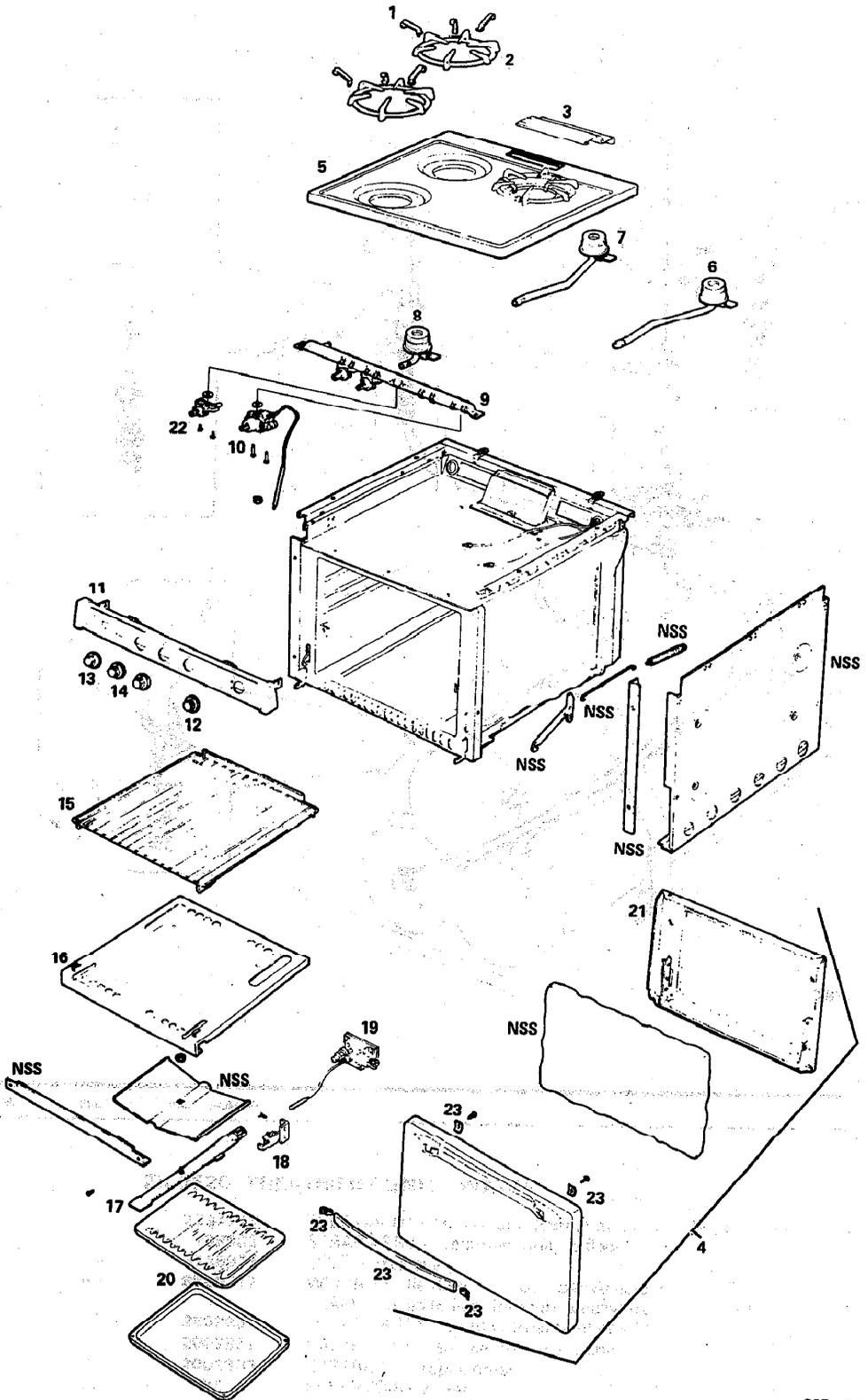

FURNISHINGS

KEY 230 260 PART NUMBER

28.054 RANGE—3 BURNER WITH OVEN (COLEMAN)

--	1	1	709146	RANGE—3 burner (Coleman) (prior to 1975) (incl. next 23 items)
1	1	1	709133	CLIP—grate (package)
2	3	3	709130	GRATE—top burner
3	1	1	709148	DEFLECTOR—flue
4	1	1	710032	DOOR ASSY.—oven complete (incl. glass)
5	1	1	709145	TOP—cook
6	1	1	709558	BURNER—top, without lighter (right rear)
7	1	1	709560	BURNER—top, without lighter (left rear)
8	1	1	709562	BURNER—top, without lighter (front)
9	1	1	709150	PIPE ASSY.—manifold (SOA)
10	1	1	709571	THERMOSTAT
11	1	1	709551	COVER ASSY.—manifold (SOA)
12	1	1	709149	DIAL—thermostat
13	1	1	709556	KNOB—valve (front)
14	2	2	709557	KNOB—valve (rear)
15	1	1	709579	RACK—oven
16	1	1	709583	BOTTOM ASSY.—oven (SOA)
17	1	1	709552	BURNER—oven
18	1	1	709553	BURNER—oven pilot
19	1	1	709142	VALVE—oven safety
20	1	1	709593	PAN ASSY.—2 piece broiler
21	1	1	709139	PANEL ASSY.—door (plain) (SOA)
22	3	3	709132	VALVE—top burner
23	1	1	709578	HANDLE—oven door

FURNISHINGS

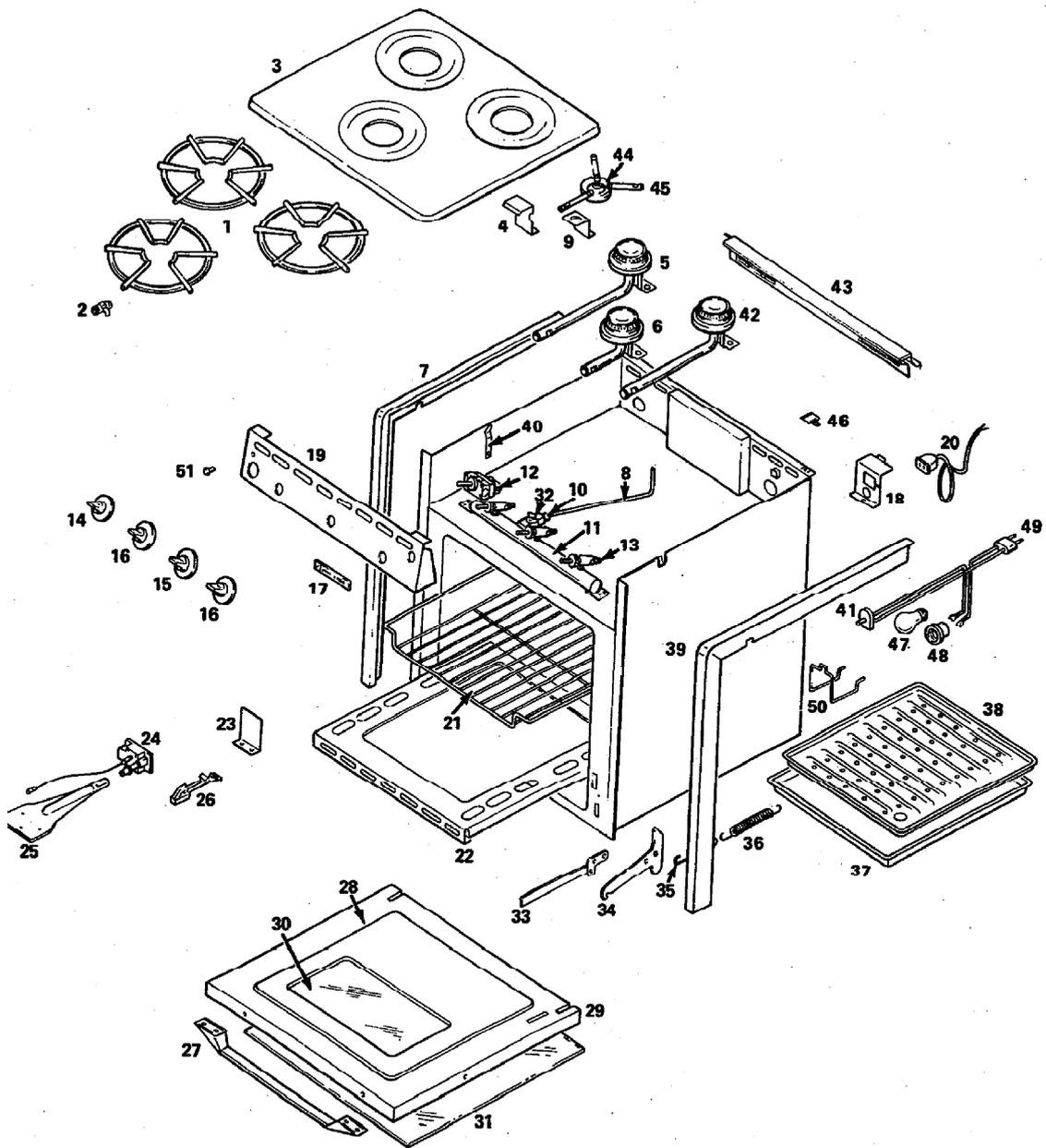

28P-29

28.054A RANGE - 3 BURNER WITH OVEN (MAGIC CHEF)

FURNISHINGS

KEY 230 260 PART NUMBER

28.054A RANGE—3 BURNER WITH OVEN (MAGIC CHEF)

—	—	1	724478	RANGE ASSY.—3 burner (w/black glass door & oven light) (incl. following items thru asterisk*)
1	—	3	796141	GRATE—top burner
2	—	4	796186	NUT—tee
3	—	1	796140	TOP—range
4	—	1	796142	SHIELD—pilot, top
5	—	1	796152	BURNER—rear (LH)
6	—	1	796151	BURNER—front
7	—	1	796160	TRIM—side (LH)
8	—	1	796154	TUBE—pilot
9	—	1	796143	SUPPORT—pilot, top
10	—	1	796155	FILTER—pilot
11	—	1	796156	PIPE—manifold
12	—	1	796157	THERMOSTAT
13	—	1	796144	VALVE—burner, top
14	—	1	796150	DIAL—thermostat
15	—	1	796145	KNOB—top burner, front
16	—	2	796146	KNOB—top burner, rear
17	—	1	796196	PLATE—name
18	—	1	796163	SUPPORT—receptacle
19	—	1	796161	PANEL—manifold
20	—	1	796164	CORD—service
21	—	1	796168	RACK—oven
22	—	1	NPN	BOTTOM—oven
23	—	1	796169	STOP—broiler pan
24	—	1	796170	VALVE—burner, oven
25	—	1	796171	BURNER—oven (also use 1-796172 air shutter)
—	—	1	796172	AIR SHUTTER—oven burner (w/796171 burner—oven)
26	—	1	796173	PILOT—oven
27	—	1	796176	HANDLE—oven door
28	—	1	796177	LINER—oven door
29	—	1	796178	FRAME—door glass
30	—	1	796179	GLASS—door inner
31	—	1	796180	GLASS—front
32	—	1	796147	VALVE—shut—off, top pilot
33	—	1	796138	HINGE ASSY.—door (RH)
33	—	1	796139	HINGE ASSY.—door (LH)
34	—	1	796181	ARM—spring hinge
35	—	1	796182	HOOK—spring, oven door
36	—	1	796183	SPRING—door
37	—	1	796174	PAN broiler, oven
38	—	1	796175	INSERT—broiler pan
39	—	1	796159	TRIM—side (RH)
40	—	1	796149	CLIP—top hold down
41	—	1	796166	SWITCH—oven light
42	—	1	796153	BURNER—rear (RH)
43	—	1	796162	DEFLECTOR—flue
44	—	1	796136	CUP ASSY.—lighter
45	—	3	796158	TUBE—flash
46	—	2	796148	SPRING—rear, top
47	—	1	709135	BULB—light, oven
48	—	1	NPN	RECEPTACLE—light
49	—	1	796165	HARNESS—light, oven
50	—	1	796167	GUARD—bulb
51	—	1	796195	BUTTON—indicator
—	—	1	796137	RETAINER—glass assembly
—	—	1	796184	FITTING—thermostat inlet
—	—	1	796185	CLIP—oven rack
—	—	1	799874	LABEL—range warning
—	—	1	2005742	RANGE ASSY.—3 burner (w/brushed chrome oven door) (incl. following items thru asterisk **)
—	—	1	2030002	CUP ASSY.—lighter (SOA)
—	—	1	2030003	HINGE ASSY.—RH door (SOA)
—	—	1	2030004	HINGE ASSY.—LH door (SOA)
—	—	1	796140	TOP—main

FURNISHINGS

KEY 230 260 PART NUMBER

28.054A RANGE—3 BURNER WITH OVEN (MAGIC CHEF) (Cont.)

—	—	3	2030013	GRATE—top
—	—	1	796142	SHIELD—top pilot
—	—	1	796143	SUPPORT—top pilot
—	—	1	796144	VALVE—top burner
—	—	1	796145	KNOB—front top burner
—	—	1	2030014	KNOB—rear top burner
—	—	1	2030015	VALVE—top pilot shut-off
—	—	2	2030016	SPRING—main top rear
—	—	1	796149	CLIP—main top hold down
—	—	1	2030017	TUBE—valve (1/4")
—	—	1	2030018	TUBE—oven pilot
—	—	1	2030020	BURNER—front
—	—	1	2030021	BURNER—left rear
—	—	1	2030022	BURNER—right rear
—	—	1	2030023	TUBE—pilot
—	—	1	796155	FILTER—pilot
—	—	1	796156	PIPE—manifold
—	—	1	2030024	THERMOSTAT—range
—	—	3	796158	TUBE—flash
—	—	1	2030050	CLIP—tube
—	—	1	2030025	TRIM—RH side
—	—	1	2030026	TRIM—LH side
—	—	1	2030027	PANEL—manifold
—	—	1	796162	DEFLECTOR—flue
—	—	1	2030028	FERRULE—range (3/16")
—	—	1	2030030	SHIELD—heat
—	—	1	2030049	SPREADER—flame
—	—	1	2030051	RACK—oven
—	—	1	2030052	TRIM—manifold panel
—	—	1	2030053	TRIM—manifold
—	—	1	796169	STOP—broiler pan
—	—	1	796170	VALVE—oven burner
—	—	1	796171	BURNER—oven
—	—	1	2030054	PILOT—oven
—	—	1	796174	PAN—oven broiler
—	—	1	796175	INSERT—broiler door
—	—	1	2030055	PANEL—oven door
—	—	1	2030056	HANDLE—oven door
—	—	1	NPN	LINER—oven door (Magic Chef # 50-22022-3) (procure from Magic Chef Co.)
—	—	1	2030057	BOTTOM—oven
—	—	1	2030058	SPRING—bottom
—	—	1	796181	ARM—spring hinge
—	—	1	796182	HOOK—oven door spring
—	—	1	2030059	SPRING—door
—	—	1	796184	FITTING—thermostat inlet
—	—	1	2030060	CLIP—oven rack
—	—	4	2030061	NUT—tee
—	—	1	796195	BUTTON—indicator
—	—	1	796196	NAMEPLATE—range
—	—	1	2030062	CLIP—bulb
—	—	1	2030063	NUT—compression
—	—	1	2030064	NUT—range (3/16")
—	—	2	* 2030065	NUT—range (1/4")

28.054B RANGE—3 BURNER WITHOUT OVEN (MAGIC CHEF)

—	—	1	2025476	RANGE ASSY.)3 burner (w/o oven) (w/RPO 685) (incl. items thru asterisk)
—	—	1	2030083	BOX—burner
—	—	1	2030022	BURNER—RH rear
—	—	1	2030021	BURNER—LH rear
—	—	1	2030020	BURNER—front
—	—	1	796195	BUTTON—indicator
—	—	3	2030050	CLIP—flash tube
—	—	3	2030060	CLIP—grate

FURNISHINGS

KEY 230 260 PART NUMBER

28.054B RANGE—3 BURNER WITHOUT OVEN (MAGIC CHEF) (Cont.)

—	—	1	796149	CLIP—main top
—	—	1	2030002	CUP—lighter
—	—	1	2030084	FERRULE—
—	—	1	2030087	FILTER—pilot
—	—	3	2030013	GRATE—burner
—	—	1	796145	KNOB—front burner
—	—	2	2030014	KNOB—rear burner
—	—	1	796196	PLATE—name
—	—	1	2030088	NUT—compressor
—	—	3	2030061	NUT—tee
—	—	1	2030089	PANEL—manifold
—	—	1	2030090	PIPE—manifold
—	—	1	796142	SHIELD—pilot
—	—	1	2030091	SUPPORT—pilot
—	—	1	796140	TOP—main
—	—	1	2030092	TRIM—box RH
—	—	1	2030093	TRIM—box LH
—	—	1	2030052	TRIM—manifold panel
—	—	1	2030096	TRIM—top rear
—	—	1	2030097	TUBE—pilot
—	—	1	2030098	TUBE—pilot
—	—	3	796144	VALVE—burner
—	—	3	* 2030015	VALVE—shut off
—	—	1	2025475	OVEN—microwave (w/RPO 685) (ref. only) (procure oven and component parts from LITTON CO. model No. 102.002)
—	—	2	NPN	BRACKET—microwave bracket (w/RPO 685) (ref. 2026272) (make locally)
—	—	1	2029240	OVEN—microwave (w/RPO UND) (1978) (Thermador Co. model no. MC17)

FURNISHINGS

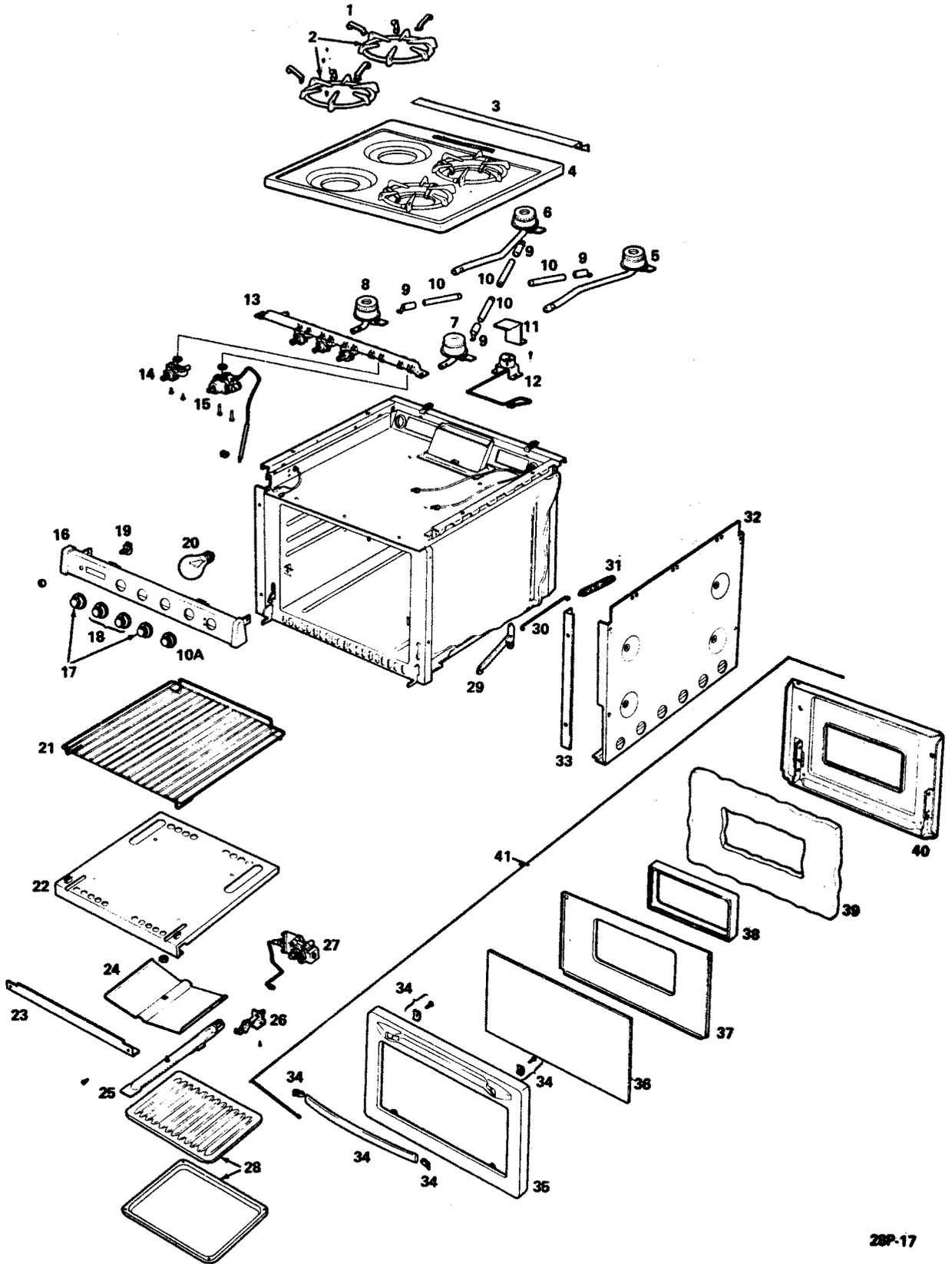

28.055 RANGE - 4 BURNER WITH OVEN (COLEMAN)

FURNISHINGS

KEY 230 260 PART NUMBER

28.055 RANGE—4 BURNER WITH OVEN (COLEMAN)

—	1	1	709136	RANGE—4 burner
1	1	1	709133	CLIP—grate (package)
2	4	4	709130	GRATE
3	1	1	709570	FLUE—deflector
4	1	1	709569	TOP—cook
5	1	1	709559	BURNER—top with lighter (right rear)
6	1	1	709561	BURNER—top with lighter (left rear)
7	1	1	709564	BURNER—top with lighter (right front)
8	1	1	709566	BURNER—top with lighter (left front)
9	4	4	709131	CONNECTOR—flash tube
10	4	4	709594	TUBE—flash
10A	1	1	709575	DIAL—thermostat
11	1	1	NPN	SHIELD—pilot light
12	1	1	709584	LIGHTER ASSY.—top (SOA)
13	1	1	709582	PIPE ASSY.—manifold (SOA)
14	4	4	709592	VALVE—top burner
15	1	1	709572	THERMOSTAT
16	1	1	709585	COVER ASSY.—manifold (SOA)
17	2	2	709556	KNOB—valve, front
18	2	2	709557	KNOB—valve, rear
19	1	1	709580	SWITCH—oven light
20	1	1	709135	BULB—oven light (12 volt)
21	1	1	709579	RACK—oven
22	1	1	709583	BOTTOM ASSY.—oven (SOA)
23	1	1	NS	SUPPORT—oven bottom
24	1	1	NS	SHIELD—oven burner
25	1	1	709552	BURNER—oven
26	1	1	709555	BURNER—pilot
27	1	1	709143	VALVE—safety
28	1	1	709593	PAN ASSY.—2 piece broiler (SOA)
29	2	2	NS	ARM—door stop
30	2	2	NS	ROD—door stop arm
31	2	2	NS	SPRING—door stop arm
32	1	1	NS	PANEL—side
33	1	1	709138	TRIM—front
34	1	1	709578	HANDLE—oven door
35	1	1	709140	FRAMING—door panel
36	1	1	709144	GLASS—black
37	1	1	NPN	INNER LINER—black glass
38	1	1	709567	WINDOW ASSY.—(SOA)
39	1	1	NPN	PANEL—fiberglass
40	1	1	709141	LINER ASSY.—door (SOA)
41	1	1	710032	DOOR ASSY.—oven, complete (incl. glass)

FURNISHINGS

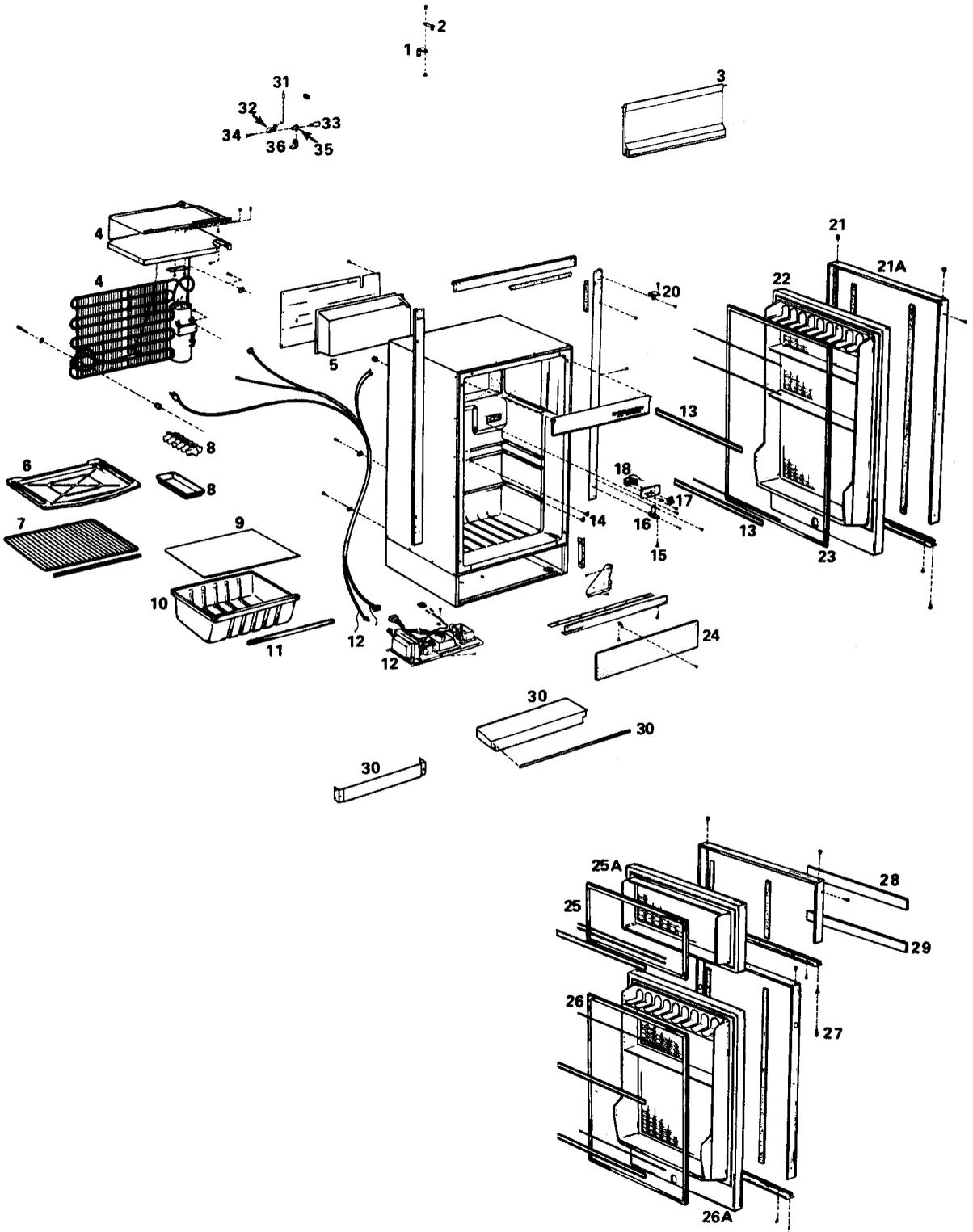

28P-42-1077

FURNISHINGS

KEY 230 260 PART NUMBER

28.056 REFRIGERATOR—ALL ELECTRIC (6 & 7.5 CU. FT.) (NORCOLD)

—	—	1	2006602	REFRIGERATOR—electric, 6 cubic foot (w/ZEO6582, ZEO6584)
—	1	1	704935	REFRIGERATOR—electric, 6 cubic foot
—	—	1	704936	REFRIGERATOR—electric, 7.5 cubic foot (w/ZEO6581) (ref. only) (prior to 1978)
—	—	1	2031329	REFRIGERATOR—electric, 7.5 cubic foot (w/ZEO6581) (1978) (Norcold Model No. DE-728G1) (details not available at time of publication)
1	1	1	2003429	LATCH—travel LH (repl. 705401, 705424) (w/704935 & 704936 refrig.)
2	1	1	2003430	LATCH—travel RH (repl. 705404, 705426) (w/704935 & 704936 refrig.)
2A	1	1	705420	GASKET—door evaporator (6 cubic ft.) (w/704935 refrig.)
3	1	1	705416	DOOR ASM.—evaporator (6 cubic ft.) (w/704935 refrig.)
3	1	1	2028675	DOOR ASSY.—evaporator (SOA) (6 cubic ft.) (w/2006602 refrig.)
4	1	1	705418	COOLING UNIT—refrigerator (SOA) (6 cubic ft.) (w/704935 & 2006602 refrig.)
4	—	1	704937	COOLING UNIT—refrigerator (SOA) (7.5 cubic ft.) (w/704936 refrig.)
5	1	1	705423	COVER—blind (6 cubic ft.) (w/704935 refrig.)
5	—	1	704951	COVER—blind (7.5 cubic ft.) (w/704936 refrig.)
5	—	1	2028687	COVER—blind (6 cubic ft.) (w/2006602 refrig.)
6	1	1	705433	TRAY—drip (6 cubic ft.) (w/704735 refrig.)
6	—	1	705414	TRAY—drip (7.5 cubic ft.) (w/704736 refrig.)
6	—	1	2028691	TRAY—drip (6 cubic ft.) (w/2006602 refrig.)
7	1	1	705434	SHELF—wire (6 cubic ft.) (w/704935 refrig.)
7	—	2	705415	SHELF—wire (7.5 cubic ft.) (w/704936 refrig.)
8	1	1	705413	TRAY—cube ice (6 cubic ft.) (w/704935 & 2006602 refrig.)
8	—	2	705413	TRAY—cube ice (7.5 cubic ft.) (w/704936 refrig.)
9	1	1	705431	COVER—crisper (6 cubic ft.) (w/704935 refrig.)
9	—	1	705432	COVER—crisper (7.5 cubic ft.) (w/704936 refrig.)
10	1	1	705430	CRISPER—(6 cubic ft.) (w/704935 refrig.)
10	—	1	705408	CRISPER—(7.5 cubic ft.) (w/704936 refrig.)
10	—	1	2028689	CRISPER—(6 cubic ft.) (w/2006602 refrig.)
11	1	1	705429	TRIM—crisper (6 cubic ft.) (w/704935 refrig.)
11	—	1	705407	TRIM—crisper (7.5 cubic ft.) (w/704936 refrig.)
11	—	1	2028690	TRIM—crisper (6 cubic ft.) (w/2006602 refrig.)
12	1	1	716118	INVERTER ASSY.—including wiring (6 cubic ft.) (w/704935 refrig.)
12	—	1	2028676	INVERTER ASSY.—(6 cubic ft.) (w/2006602 refrig.)
12	—	1	2011861	INVERTER ASSY.—service (7.5 cubic ft.) (w/704936 refrig.) (stamped on inverter 634) (repl. 716119) (also use 1-2011860 transformer assy.) (9 wire white adapter w/Norcold Serial No. 1142-5802) (first design)
—	—	1	2011860	TRANSFORMER ASSY.—inverter (w/7.5 cubic ft refrig) (w/704936 refrig.) (stamped on transformer U64A) (w/2011861 inverter assy.) (9 wire white adapter w/Norcold Serial No. 1142-5802) (first design)
12	—	1	2037879	INVERTER ASSY.—(7.5 cubic ft.) (ref. only) (incl. the (2) items)
12	—	1	2037881	INVERTER ASSY.—service (7.5 cubic ft.) (also use 1-2037880 transformer) (7 wire black adapter eff. w/Norcold Serial No. 6002) (second design)
—	—	1	2037880	TRANSFORMER ASSY.—inverter service (7.5 cubic ft.) (also use 1-2037881 inverter) (7 wire black adapter eff. w/Norcold Serial No. 6002) (second design)
—	—	1	NPN	BREAKER ASSY.—circuit (w/neon light & red button)
13	2	2	705428	TRIM—door rail (6 cubic ft.) (w/704935 refrig.)
13	—	3	705406	TRIM—door rail (7.5 cubic ft.) (w/704936 refrig.)
13	—	1	2028678	TRIM ASSY.—door rail (6 cubic ft.) (w/2006602 refrig.)
14	2	2	704950	CLIP—shelf (6 & 7.5 cubic ft.)
15	2	2	704948	PINS—hinge (6 & 7.5 cubic ft.)
16	2	2	704947	HINGE—left hand (6 & 7.5 cubic ft.)
17	1	1	704940	KNOB—thermostat (w/6 & 7.5 cubic ft.) (w/704935 & 704936 refrig.)
17	—	1	2028685	KNOB—thermostat (6 cubic ft.) (w/2006602 refrig.)
18	1	1	704939	THERMOSTAT ASM.—refrigerator (SOA) (w/6 & 7.5 cubic ft.) (w/704935 & 704936 refrig.)
18	—	1	2028677	THERMOSTAT ASSY.—(6 cubic ft.) (w/2006602 refrig.)
19	6	6	705427	RAIL—door (6 cubic ft.) (w/704935 refrig.)
19	—	7	705405	RAIL—door (7.5 cubic ft.) (w/704936 refrig.)

FURNISHINGS

KEY	230	260	PART NUMBER	
28.056 REFRIGERATOR—ALL ELECTRIC (6 & 7.5 CU. FT.) (NORCOLD)				
(Cont.)				
19	—	1	2028681	RAIL—door (6 cubic ft.) (w/2006602 refrig.)
20	2	2	704946	HINGE—right hand (6 cubic ft.) (w/704935 & 2006602 refrig.)
20	—	3	704946	HINGE—right hand (7.5 cubic ft.) (w/704936 refrig.)
21	4	4	704944	BUSHING—hinge (6 cubic ft.) (w/704935 refrig.)
21	8	8	704944	BUSHING—hinge (7.5 cubic ft.)
21	—	2	2028684	BUSHING—hinge (6 cubic ft.) (w/2006602 refrig.)
21A	—	1	2028679	FRAME—door (6 cubic ft.) (w/2006602 refrig.)
22	1	1	705419	DOOR—refrigerator (less panel) (6 cubic ft.) (w/704935 refrig.)
22	—	1	2028680	DOOR ASSY.—(less frame, lock & panel) (6 cubic ft.) (w/2006602 refrig.)
23	1	1	705422	GASKET—door (6 cubic ft.) (w/704935 refrig.)
23	—	1	2028682	GASKET—door (6 cubic ft.) (w/2006602 refrig.)
24	1	1	705421	PLATE—kick (6 cubic ft.) (w/704935 refrig.)
24	—	1	2028686	PLATE—kick (6 cubic ft.) (w/2006602 refrig.)
24	—	1	704941	PLATE—kick (7.5 cubic ft.) (w/704936 refrig.)
25	—	1	704943	GASKET—top door (7.5 cubic ft.) (w/704936 refrig.)
25A	—	1	704942	DOOR—top, refrigerator (7.5 cubic ft.) (first design) (w/704936 refrig.)
25A	—	1	2028672	DOOR—top, refrigerator (7.5 cubic ft.) (second design) (eff. w/1976) (w/704936 refrig.)
26	—	1	704945	GASKET—bottom door (7.5 cubic ft.) (w/704936 refrig.)
26A	—	1	705758	DOOR—bottom, refrigerator (7.5 cubic ft.) (w/out built in lock) (first design) (w/704936 refrig.)
26A	—	1	2028671	DOOR—bottom, refrigerator (7.5 cubic ft.) (w/built in lock) (second design) (w/704936 refrig.) (eff. w/1976) (NORCOLD # 614107-22)
27	—	1	704949	PIN—double hinge (7.5 cubic ft.) (w/704936 refrig.)
28	—	1	2019687	TRIM—decorative door (gold) (bottom of top door) (eff. w/1976) (7.5 cubic ft.) (w/704936 refrig.)
29	—	1	2019688	TRIM—decorative door (gold) (top of bottom door) (name plate) (eff. w/1976) (7.5 cubic ft.) (w/704936 refrig.)
30	—	1	2020252	FOAMED ASSY.—divider (eff. w/1976) (7.5 cubic ft.) (w/704536 refrig.)
31	—	1	2019689	ROD ASSY.—lock (eff. w/1976) (6 & 7.5 cubic ft.) (w/704936, & 2006602 refrig.)
32	—	1	2019690	CAM—lock (eff. w/1976) (6 & 7.5 cubic ft.) (w/704936, & 2006602 refrig.)
33	—	1	2020253	KEY—refrigerator door, square head type (eff. w/1976) (7.5 cubic ft.) (w/704936 refrig.)
33	—	1	2028692	KEY—lock (6 cubic ft.) (w/2006602 refrig.) (ref. only) (procure locally) (Norcold # 614153)
34	—	1	2019694	SCREW—lock (eff. w/1976) (6 & 7.5 cubic ft.) (w/704936 & 2006602 refrig.)
35	—	1	2019695	LOCK—refrigerator (eff. w/1976) (7.5 cubic ft.) (w/704936 refrig.)
36	—	1	2019696	CLIP—lock (eff. w/1976) (6 & 7.5 cubic ft.) (w/704936 & 2006602 refrig.)
—	1	1	—	PANEL—(front of refrig. door) top/bottom (see group 28.168)
—	—	1	791953	TRAY ASSY.—refrigerator drain (prior to Serial No. 6V100878)
—	—	1	791966	SEAL—drain
—	—	2	791817	BRACKET—refrigerator module to floor
—	—	1	791818	BRACKET—refrigerator module to floor
—	—	1	792167	BRACKET—refrigerator to side member mounting
—	—	AR	8885533	SECTION—extruded expan. elastic (between module and ceiling) (100' roll cti.)
—	—	1	2028683	TRIM—decorative (single door) 6 cubic ft.) (w/2006602 refrig.)

FURNISHINGS

NOTES

FURNISHINGS

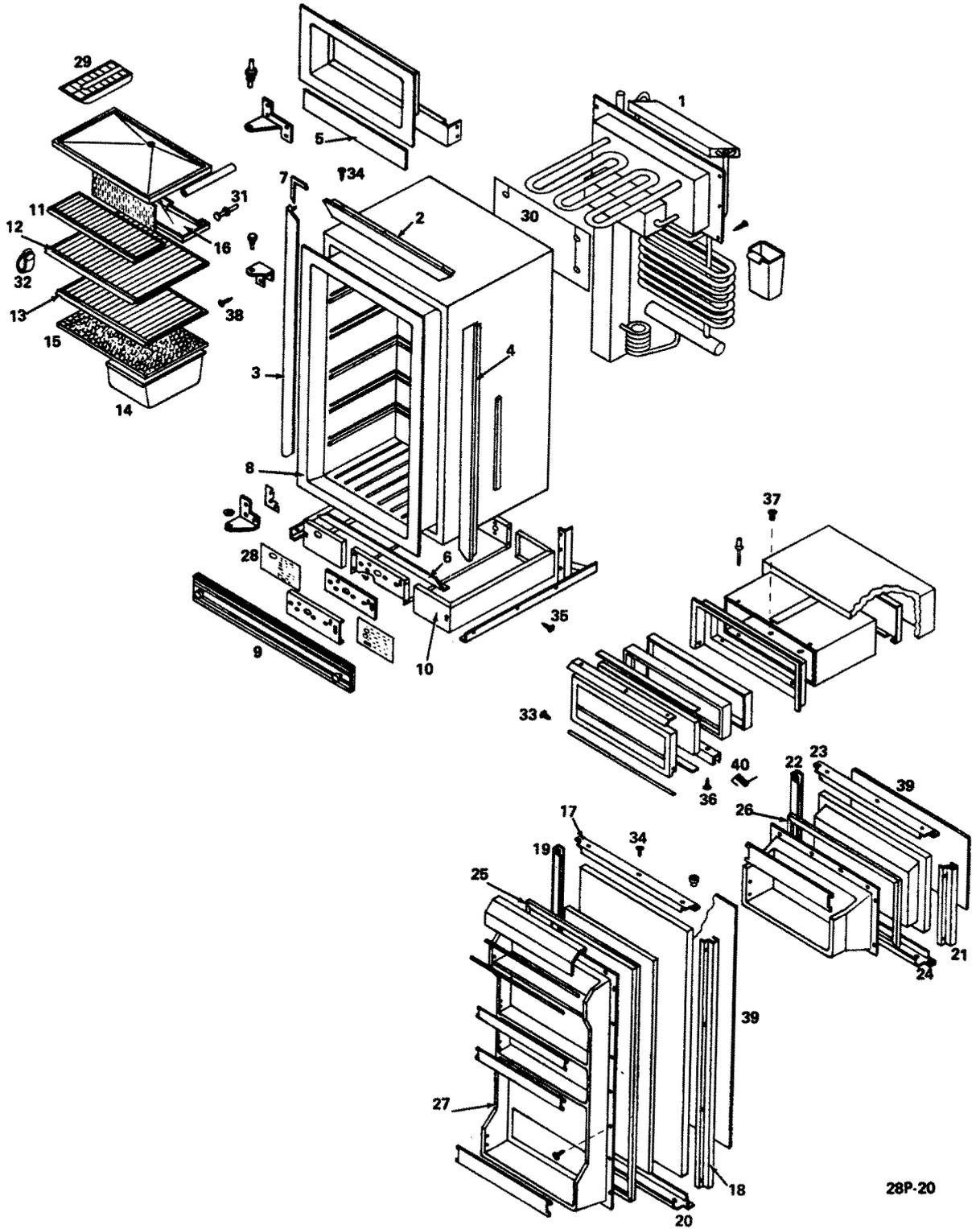

28P-20

28.057 REFRIGERATOR - GAS/ELECTRIC (6 & 7 CU. FT.) (INSTA-MATIC)

FURNISHINGS

KEY 230 260 PART NUMBER

28.057 REFRIGERATOR—GAS/ELECTRIC (6 & 7 CU. FT.) (INSTA—MATIC)

—	1	1	710958	REFRIGERATOR ASSY.—6 cubic foot
—	—	1	—	REFRIGERATOR ASSY.—7 cubic foot (ref. only) (use 704936) (NORCOLD) (ref. 710959)
1	1	1	710960	UNIT—cooling, 12 volt and 115 volt (6 cubic ft.)
1	—	1	711007	UNIT—cooling, 12 volt and 115 volt (7 cubic ft.)
2	1	1	710963	FRAME—body top (6 cubic ft.)
2	1	1	711017	FRAME—body top (7 cubic ft.)
3	1	1	710964	FRAME—body sides, LH (6 cubic ft.)
3	1	1	711018	FRAME—body sides, LH (7 cubic ft.)
4	1	1	710965	FRAME—body sides, RH (6 cubic ft.)
4	—	1	711019	FRAME—body sides, RH (7 cubic ft.)
5	—	1	711020	FRAME—body, bottom middle (7 cubic ft.)
6	1	1	710966	FRAME—body, bottom (6 cubic ft.)
6	—	1	711021	FRAME—body, bottom (7 cubic ft.)
7	2	2	710967	BRACE—corner, body frame
8	1	1	710968	LINER—body (6 cubic ft.)
8	—	1	711027	LINER—body (7 cubic ft.)
9	1	1	710961	SHUTTER ASSY.—(6 cubic ft.)
9	—	1	711011	SHUTTER ASSY.—(7 cubic ft.)
10	2	2	710974	CLIP—shutter spring
11	1	1	710969	SHELF—upper (6 cubic ft.)
11	—	1	711030	SHELF—upper (7 cubic ft.)
12	1	1	710970	SHELF—center (6 cubic ft.)
12	—	1	711031	SHELF—center (7 cubic ft.)
13	1	1	710971	SHELF—lower (6 cubic ft.)
13	—	1	711032	SHELF—lower (7 cubic ft.)
14	AR	AR	710973	BIN—vegetable (1 required w/6 cubic ft. and 2 required w/7 cubic ft.)
15	1	1	710972	SHELF—glass (6 cubic ft.)
15	—	1	711033	SHELF—glass (7 cubic ft.)
16	1	1	710962	TRAY—drip (6 cubic ft.)
16	—	1	711012	TRAY—drip (7 cubic ft.)
17	1	1	710975	FRAME—door, top (6 cubic ft.)
17	—	1	711036	FRAME—door, top (7 cubic ft.)
18	1	1	710976	FRAME—door, sides, LH (6 cubic ft.)
18	—	1	711034	FRAME—door, sides, LH (7 cubic ft.)
19	1	1	710977	FRAME—door, sides, RH (6 cubic ft.)
19	—	1	711034	FRAME—door, sides, RH (7 cubic ft.)
20	1	1	710978	FRAME—door, bottom (6 cubic ft.)
20	—	1	711036	FRAME—door, bottom (7 cubic ft.)
21	—	1	711037	FRAME—door, freezer, LH (7 cubic ft.)
22	—	1	711038	FRAME—door, freezer, RH (7 cubic ft.)
23	—	1	711040	FRAME—door, freezer, top (7 cubic ft.)
24	—	1	711036	FRAME—door, freezer, bottom (7 cubic ft.)
25	1	1	710979	GASKET—door (6 cubic ft.)
25	—	1	711042	GASKET—door (7 cubic ft.)
26	—	1	711041	GASKET—door, freezer (7 cubic ft.)
27	1	1	710980	LINER—door (6 cubic ft.)
28	1	1	710984	BASE—instruction label (6 cubic ft.)
28	—	1	711046	BASE—instruction label (7 cubic ft.)
29	2	2	710982	TRAY—ice cube
30	1	1	710983	COVER—secondary evaporator (6 cubic ft.)
30	—	1	711047	COVER—secondary evaporator (7 cubic ft.)
31	4	4	710985	RIVET—drip tray
32	1	1	—	CLAMP—nylon (procure locally)
33	AR	AR	—	SCREW—tapping, washer face (No. 8 x 3/8) (20 required w/6 cubic ft. and 32 required w/7 cubic ft.) (procure locally)
34	AR	AR	—	SCREW—tapping, RH (No. 10 x 3/8) (25 required w/6 cubic ft. and 35 required w/7 cubic ft.) (procure locally)
35	8	8	—	SCREW—tapping, RH (No. 10 x 3/8) (procure locally)
36	8	8	—	SCREW—tapping, RH (No. 8 x 1/2) (procure locally)
37	5	5	—	SCREW—RH (No. 10—24 x 3/4) (procure locally)
38	AR	AR	—	SCREW—tapping, RH (No. 10 x 3/4) (22 required w/6 cubic ft. and 28 required w/7 cubic ft.) (procure locally)
39	1	1	—	PANEL—(see group 28.168)
40	1	1	710981	SPRING—freezer door (6 cubic ft.)
—	1	—	704152	PIPE ASSY.—liquid propane
—	—	1	704153	PIPE—liquid propane
—	1	1	710986	SWITCH ASSY.—electric control (6 cubic ft.)
—	1	1	710987	THERMOSTAT ASSY.—electric (6 cubic ft.)

FURNISHINGS

KEY 230 260 PART NUMBER

**28.057 REFRIGERATOR—GAS/ELECTRIC (6 & 7 CU. FT.) (INSTA—MATIC)
(Cont.)**

—	1	1	710988	CONTROL ASSY.—gas (6 cubic ft.)
—	1	1	710989	VALVE ASSY.—gas shut off (6 cubic ft.)
—	1	1	710990	BURNER ASSY.—ignitor (6 cubic ft.)
—	1	1	710991	IGNITOR ASSY.—burner (6 cubic ft.)
—	1	1	710992	ORIFICE—burner
—	1	1	710993	FITTING—burner orifice
—	1	1	710994	COUPLE—thermo
—	1	1	710995	PLUG—ignitor
—	1	1	710996	TUBE—heat shrink
—	1	1	710997	BRACKET—ignitor
—	1	1	710998	ELEMENT—heating (6 cubic ft.)
—	1	1	710999	BUSHING—thermo couple
—	1	1	711000	BUSHING—gas line strain
—	1	1	711001	BUSHING—strain ignitor
—	1	1	711002	KNOB—electric thermostat
—	1	1	711006	KNOB—gas shut off valve
—	—	1	711043	LINER—refrigerator door (7 cubic ft.)
—	—	1	717856	ORIFICE—burner (7 cubic ft.) (repl. 711049)
—	—	1	711050	ELEMENT—burner heating (7 cubic ft.)
—	2	2	2490119	CLIP—pipe, liquid propane

FURNISHINGS

NOTES

FURNISHINGS

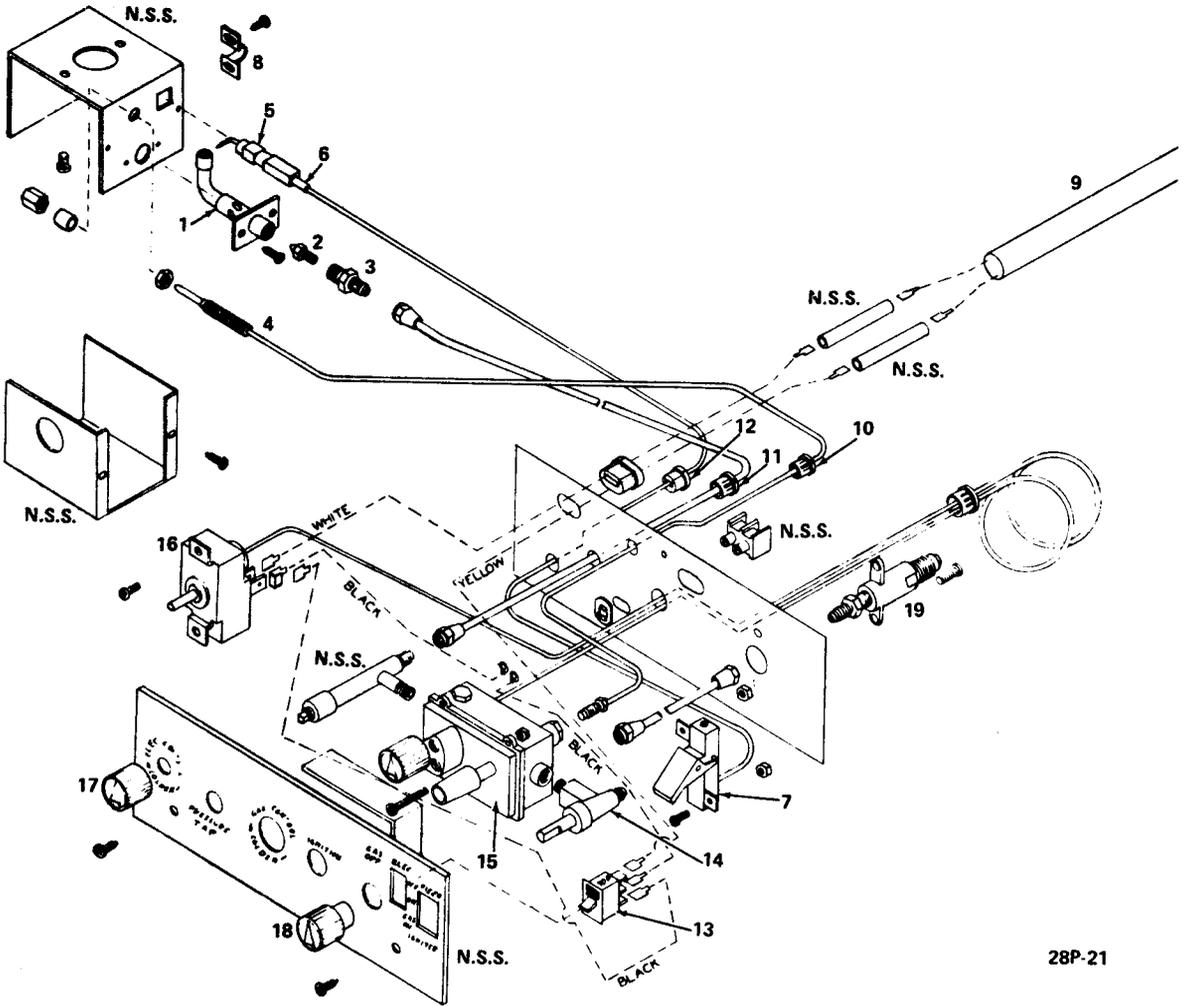

28P-21

28.057A CONTROLS – GAS/ELECTRIC REFRIGERATOR (INSTA-MATIC)

FURNISHINGS

KEY 230 260 PART NUMBER

28.057A CONTROLS—GAS/ELECTRIC REFRIGERATOR (INSTA—MATIC)

NOTE: Parts not keyed on illustration are not serviced.

1	1	1	710990	BURNER
2	1	1	710992	ORIFICE—burner (6 cubic ft.)
2	—	1	717856	ORIFICE—burner (7 cubic ft.)
3	1	1	710993	FITTING—burner orifice
4	1	1	710994	COUPLE—thermo
5	1	1	710995	PLUG—igniter
6	1	1	710996	TUBE—shrink
7	1	1	710991	IGNITER—burner (plezo)
8	1	1	710997	BRACKET—igniter
9	1	1	710998	ELEMENT—heating (6 cubic ft.)
9	—	1	711050	ELEMENT—heating (7 cubic ft.)
10	1	1	710999	BUSHING—thermo couple
11	1	1	711000	BUSHING—gas line
12	1	1	711001	BUSHING—igniter tube
13	1	1	710986	SWITCH—electric control
14	1	1	710989	VALVE—gas, shut—off
15	1	1	710988	CONTROL—gas
16	1	1	710987	THERMOSTAT—electric
17	1	1	711002	KNOB—electric
18	1	1	711006	KNOB—gas
19	1	1	715414	CONNECTOR—gas

FURNISHINGS

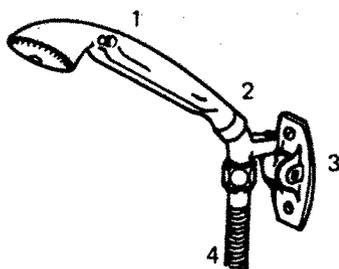

3P-14002

KEY	230	280	PART NUMBER
-----	-----	-----	-------------

28.060 SHOWER HEAD

—	1	1	702086	SHOWER ASSY.—(complete) (First Design) (with vertical wall mount) (incl. next (4) items)
1	1	1	702087	HEAD ASSY.—shower (SOA)
2	1	1	702088	CONNECTOR—shower head
3	1	1	702089	MOUNT—wall, shower head
4	1	1	702090	HOSE ASSY.—water supply (flexible) (SOA)
—	—	1	444024	ADAPTER—bath faucet to shower (1/8" to 1/2" pipe nipple to shower plumbing) (eff. w/1975)
—	—	4	—	SCREW—support, shower head hose (No. 8—32 x 7/8) (procure locally) (w/ZEO6582) (ref. 159666)
—	—	4	799378	SLEEVE ASM—screw, shower head hose support nut (w/ZEO6582) (repl. 791804)
—	—	1	2004517	SHOWER ASSY.—(head) (second design) (with horizontal wall mount) (SOA) (1977)
—	—	1	796778	VALVE ASSY.—shower vent check (1977)
—	—	1	796779	ELBOW—90 check valve (1977)
—	—	1	9427747	NIPPLE—auto pipe (1/2 x 1 1/2) (1977)
—	—	1	2002696	SEAL—nipple to bath module wall (1977)
—	—	1	8884956	TUBE—black nylon (9/32 I.D.) (1977)
—	—	1	2025601	HEAD ASSY —shower (1978)

FURNISHINGS

KEY	230	260	PART NUMBER
-----	-----	-----	-------------

28.060 SHOWER HEAD (Cont.)

—	—	1	2025602	HOSE ASSY.—shower (exc./RPO VNW) (1978)
—	—	1	2025603	HOSE ASSY.—shower (w/RPO VNW) (1978)
—	—	1	2025604	RETAINER—shower hose (1978)
—	—	2	2025600	WASHER—shower hose (1978)
—	—	1	2024405	GROMMET—shower hose (1978)
—	—	1	2025605	HOOK—shower head (1978)
—	—	2	9414754	SCREW—hook shower head (1978)
—	—	2	2025606	COVER—hook shower head screw (1978)
—	—	1	796778	VALVE ASSY.—shower head check vent (1978)
—	—	1	719178	CLIP—valve shower head (1978)
—	—	1	NPN	SCREW—clip valve shower head (procure locally) (1978)
—	—	1	796779	ELBOW—shower hose check valve (90) (1978)

FURNISHINGS

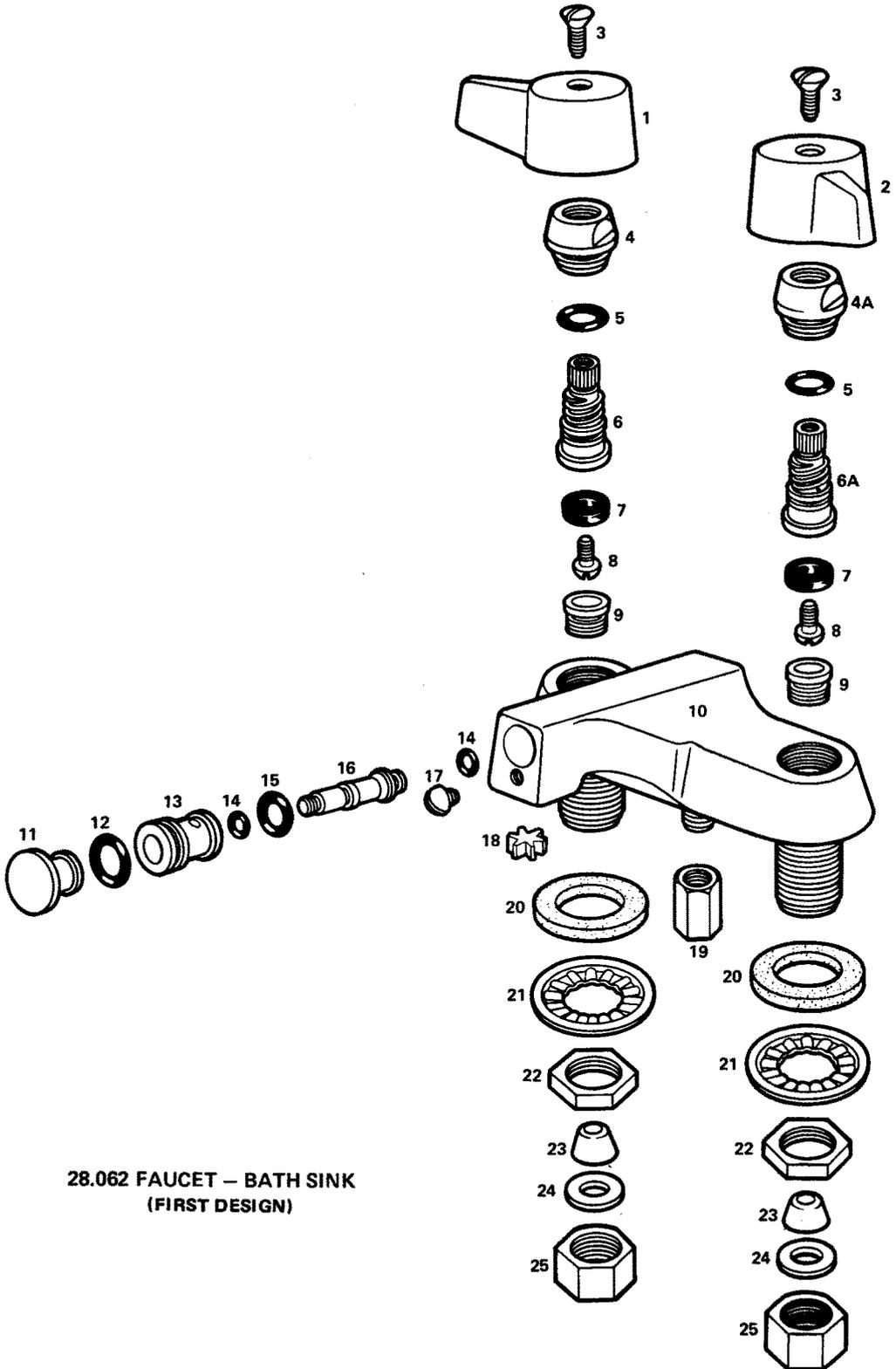

28.062 FAUCET – BATH SINK
(FIRST DESIGN)

FURNISHINGS

KEY 230 260 PART NUMBER

28.062 FAUCET—BATH SINK (FIRST DESIGN)

—	1	1	705784	FAUCET ASSY.—bath sink (exc./ZE06582)
1	1	1	705786	HANDLE—faucet (hot)
2	1	1	706130	HANDLE—faucet (cold)
3	2	2	705785	SCREW—faucet handles
4	1	1	705787	NUT—faucet gland — hot
4A	1	1	717383	NUT—faucet gland — cold
5	2	2	705788	“O” RING—faucet (110)
6	1	1	705789	STEM—faucet — hot
6A	1	1	717384	STEM—faucet — cold
7	2	2	705790	DISC—faucet stem
8	2	2	705791	SCREW—disc. faucet stem
9	2	2	705792	SEAT—disc. faucet stem
10	1	1	NS	BODY—faucet
11	1	1	705796	KNOB—diverter
12	1	1	705793	“O” RING—diverter (013)
13	1	1	705794	BUSHING—diverter
14	2	2	705795	“O” RING—diverter (008)
15	1	1	705788	“O” RING—diverter (110)
16	1	1	705798	STEM—diverter
17	1	1	705797	SCREW—diverter knob
18	1	1	NS	INSERT—anti—splash
19	1	1	NS	UNION—pip (1/4)
20	2	2	NS	WASHER—fibre
21	2	2	NS	WASHER—corrugated steel
22	2	2	NS	NUT—lock, heagon
23	2	2	NS	WASHER—cone
24	2	2	NS	WASHER—brass
25	2	2	NS	NUT—coupling

FURNISHINGS

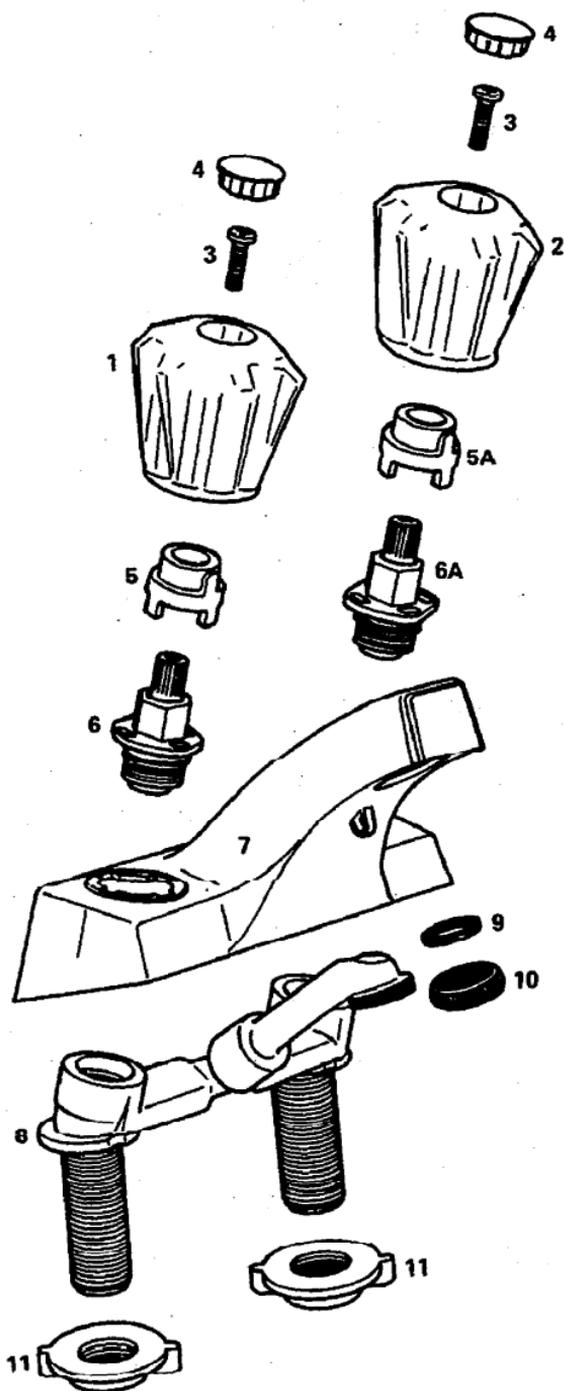

28P-39-376

28.062H FAUCET -- BATH SINK (SECOND DESIGN)

FURNISHINGS

KEY 230 260 PART NUMBER

28.062H FAUCET—BATH SINK (SECOND DESIGN)

—	—	1	2006655	FAUCET ASSY.—bath sink (SOA)
—	—	1	2006656	FAUCET ASSY.—shower (SOA) (not illus.)

NOTE: The following parts are listed for reference only.

1	—	1	NS	HANDLE—faucet (hot)
2	—	1	NS	HANDLE—faucet (cold)
3	—	1	NS	SCREW—faucet handles
4	—	1	NS	CAP—faucet handles
5	—	1	NS	NUT—faucet hot
5A	—	1	NS	NUT—faucet cold
6	—	1	NS	STEM—faucet hot
6A	—	1	NS	STEM—faucet cold
7	—	1	NS	COVER—body faucet
8	—	1	NS	BODY—faucet
9	—	1	NS	WASHER—faucet
10	—	1	NS	WASHER—faucet
11	—	1	NS	NUT—faucet

FURNISHINGS

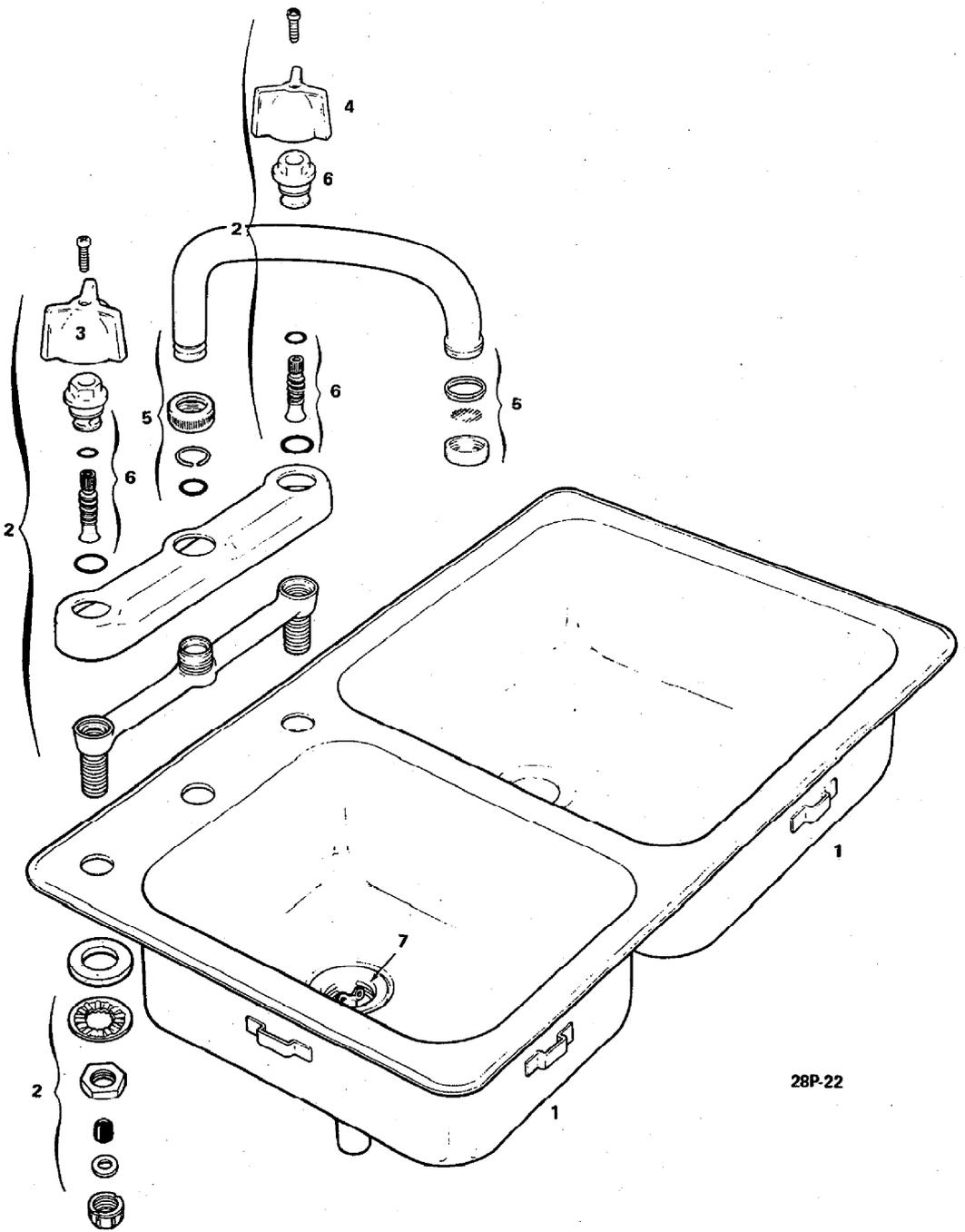

28P-22

28.063 GALLEY SINK AND FAUCET

FURNISHINGS

KEY	230	260		PART NUMBER
-----	-----	-----	--	-------------

28.063 GALLEY SINK AND FAUCET (PRIOR TO 1975)

1	1	—	707967	SINK—galley
1	—	1	707968	SINK—galley
2	1	1	706575	FAUCET ASSY.—galley sink
3	1	1	706578	HANDLE—faucet, hot
4	1	1	706579	HANDLE—faucet, cold
5	1	1	706576	SPOUT ASSY.—faucet
6	2	2	706577	CARTRIDGE ASSY.—faucet valve
7	1	1	718453	STOP—sink (strainer basket)
—	—	2	—	COVER—sink (or chopping block) (small & large) (see group 28.128)

FURNISHINGS

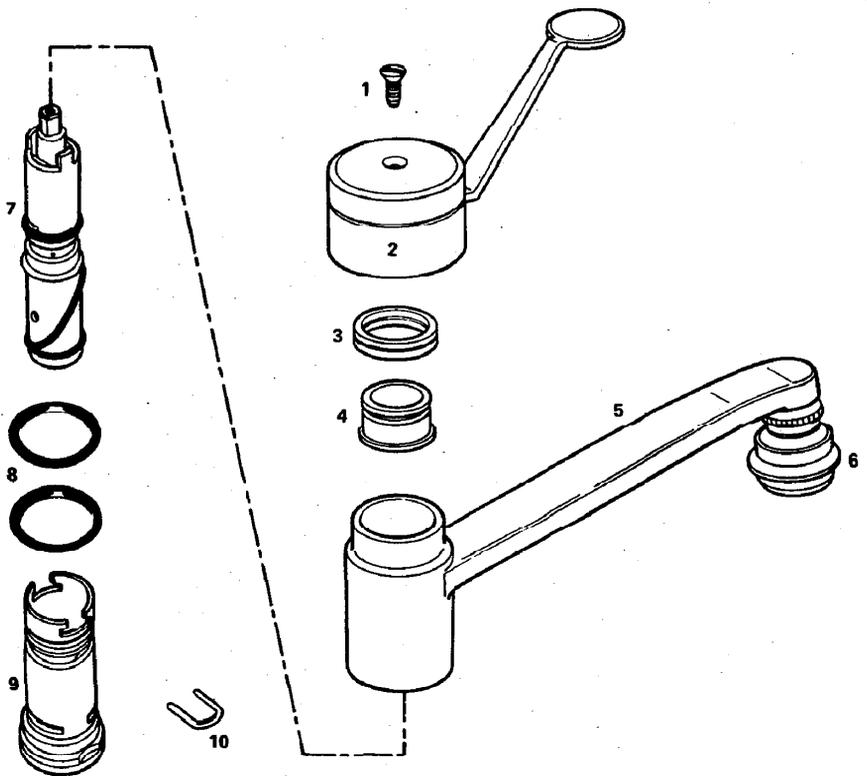

KEY	230	280	PART NUMBER
-----	-----	-----	-------------

28.064 GALLEY SINK AND FAUCET (EFF. W/1975)

—	—	1	790352	SINK—galley (eff. w/1975) (prior to 1978) (w/ZEO6581)
—	—	1	2027437	SINK ASSY.—galley (1978) (w/ZEO6581)
—	—	1	790335	FAUCET ASSY.—(complete) (incl. the next [10] items) (eff. w/1975) (prior to 1978) (exc./ZEO6582, ZEO6584)
1	—	1	794555	SCREW—handle
2	—	1	794553	HANDLE ASSY.—(SOA)
3	—	1	794556	RETAINER—nut, grooved sleeve
4	—	1	794557	SLEEVE—grooved
5	—	1	794558	SPOUT—(9")
6	—	1	2015950	AERATOR ASSY.—swivel spray (SOA) (repl. 794554)
7	—	1	794560	CARTRIDGE—valve
8	—	2	794561	SEAL—spout
9	—	1	NPN	BODY—
10	—	1	794559	CLIP—retainer
—	—	1	2028735	FAUCET ASSY.—(complete) (w/ZEO6581) (1978) (SOA)
—	—	1	2006654	FAUCET ASSY.—(complete) (w/RPO 685) (w/ZEO6581, ZEO6582, & ZEO6584) (eff. w/1976) (SOA)
—	—	1	2026865	PIPE ASSY.—elbow at galley sink (eff. w/interm 1977)
—	—	1	2026847	NUT—elbow to tee (eff. w/interm 1977)
—	—	1	2026864	WASHER—elbow to tee nut (eff. w/interm 1977)

28.064 GALLEY SINK AND FAUCET (EFF. W/1975) (Cont.)

-	-	1	2026861	PIPE ASSY.—tee at galley sink (eff. w/interm 1977)
-	-	2	2026863	SEAL—galley sink drain pipe tee to elbow (eff. w/interm 1977)
-	-	1	794562	KIT—mounting hardware

FURNISHINGS

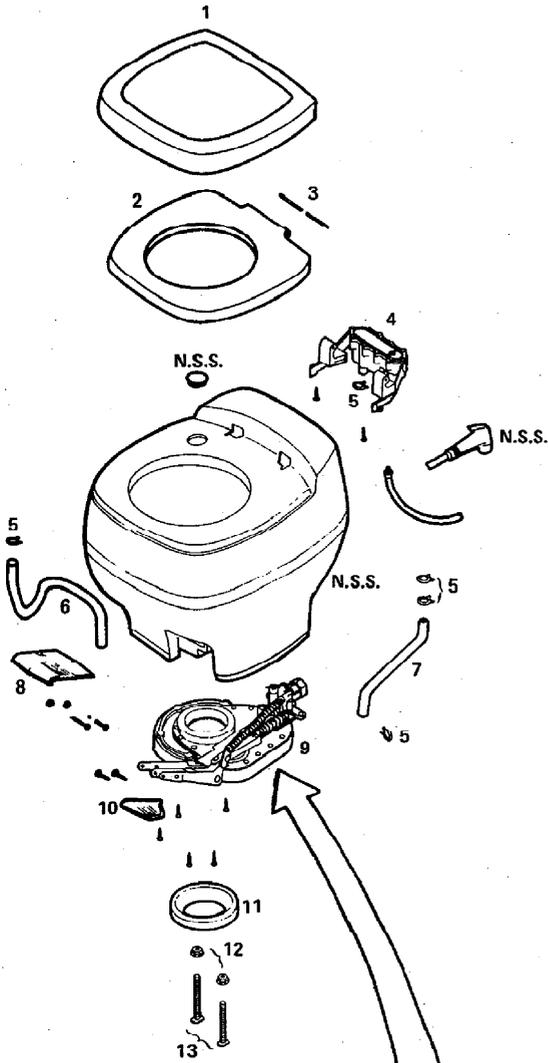

28.068 TOILET - AQUA-MAGIC

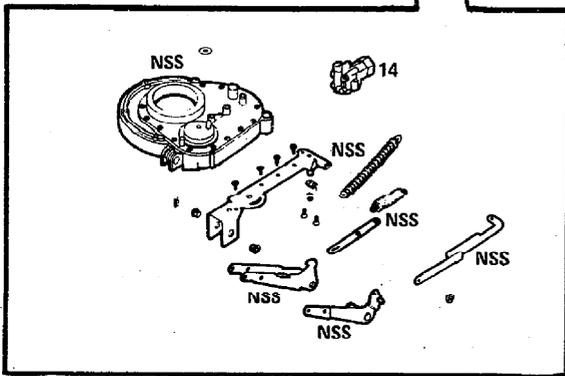

28.070 TOILET - ELECTRA-MAGIC
RECIRCULATION

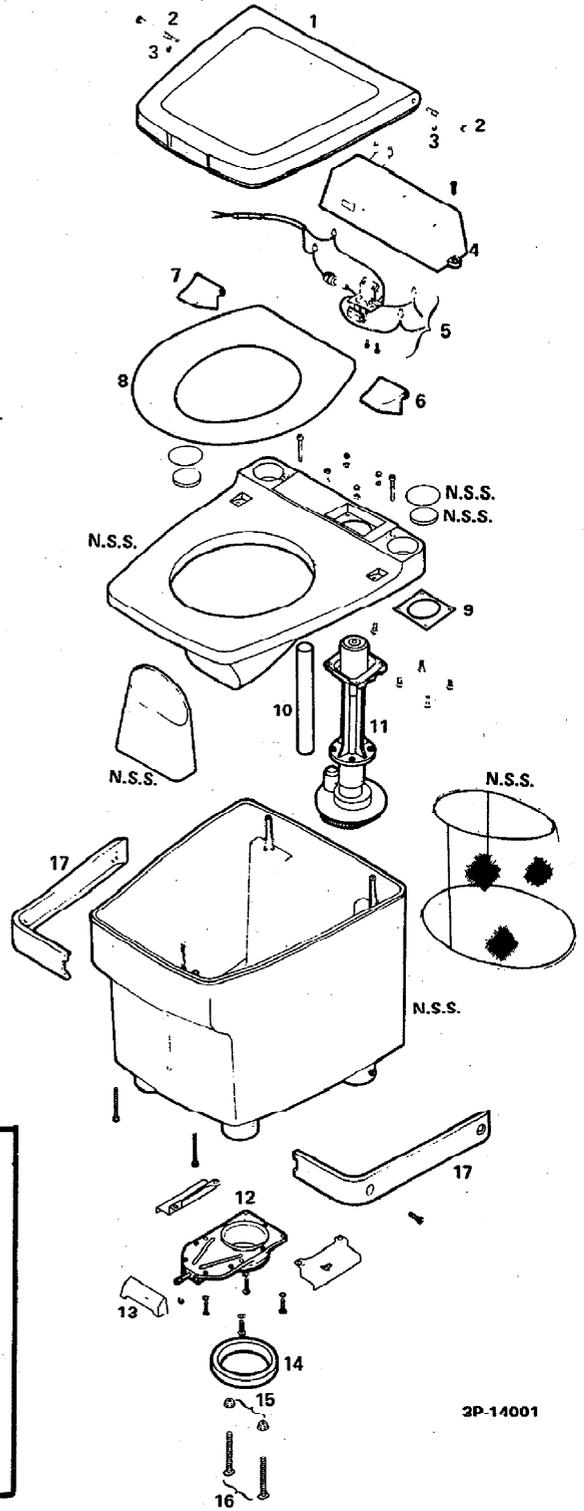

3P-14001

FURNISHINGS

KEY 230 260 PART NUMBER

28.067 TOILET PAPER AND CHEMICALS

-	1	1	705411	PAPER—toilet (package of 4) (soluble matter)
-	1	1	705409	AQUA KEM—odor control (package of 6)
-	1	1	705410	AQUA KEM—plastic cleaner (1-16 oz. bottle)
-	1	1	705412	CLEANER—aqua bowl (1-32 oz. bottle)

28.068 TOILET—AQUA—MAGIC

-	1	1	702058	TOILET ASSY.—Aqua—Magic (eff. w/ 1973 & prior to 1976) (& 1978) (white, gold & ivory)
1	1	1	711064	COVER—seat
2	1	1	711063	SEAT—toilet (repl. 702070)
3	2	2	711060	PIN—hinge
4	1	1	711061	BREAKER ASSY.—vacuum
5	5	5	-	CLAMP—trap tube (ref. 702077) (procure locally)
6	1	1	702075	TUBE—lower trap (27")
7	1	1	702076	TUBE—upper trap (20")
8	1	1	702067	PEDAL—waste trap and cleansing
9	1	1	711062	VALVE ASSY.—flush
10	1	1	702068	PEDAL—water level
11	1	1	702061	SEAL—flush valve flange
12	2	2	702069	NUT—closet bolt
13	2	2	702078	BOLT—closet
14	1	1	713334	VALVE—hall
-	1	1	2026210	TUBE ASSY.—toilet water inlet to elbow
-	1	1	798371	ADAPTER—toilet water inlet tube adapter

28.070 TOILET—ELECTRA—MAGIC

-	1	1	702736	TOILET ASSY.—(w/RPO ANW)
1	1	1	702737	COVER ASSY.—seat
2	2	2	702742	PIN—hinge, seat cover
3	2	2	702743	RING—retaining, hinge pin
4	1	1	702746	COVER—timer motor
5	1	1	702739	TIMER ASSY.—recirculating (SOA)
6	1	1	702745	HINGE—seat cover, RH
7	1	1	702744	HINGE—seat cover, LH
8	1	1	702738	SEAT ASSY.—toilet (incl. bumper) (SOA)
9	1	1	702748	GASKET—pump mounting
10	1	1	702747	TUBE—flush
11	1	1	702740	PUMP ASSY.—recirculating (incl. motor) (w/out strainer)
12	1	1	702749	VALVE—slide—ez
13	1	1	702751	HANDLE—flush
14	1	1	702061	SEAL—flange, slide—ez
15	2	2	702069	NUT—closet stud
16	2	2	702750	STUD—closet
17	1	1	716886	MOULDING—base
-	1	1	702741	KIT—refill, pump (SOA) (incl. 1-fill tube assy., 1-flange, 1-tube, 1-reflector, tape, 1-vacuum breaker, 1-shut-off valve, 1-close nipple, 1-inlet assy., 1-stand pipe, 1-socket filler, 4-screws, 1-gasket, 1-adapter-garden hose & washer-garden hose)
-	-	1	798356	TUBE ASSY.—water inlet (3/8 OD x 12" lg) (plastic nuts on both ends) (eff. w/1975) (prior to 1977)
-	-	1	798371	COUPLING—water inlet tube to shut-off valve (3/8 x 1/2 male adapter coupling) (2 7/16" lg) (eff. w/1975)
-	-	1	798357	SPIGOT—water inlet tube drain (eff. w/1975 & prior to Serial No. 6V100878)
-	-	1	2026211	TUBE ASSY.—water inlet to elbow (3/8 O.D. x 18.25 lg.) (eff. w/1977)
-	-	1	2026244	ELBOW—water inlet (90 degrees male) (eff. w/1977)
-	-	1	2026212	TUBE ASSY.—water inlet (w/RPO ANW) (3/8 O.D. x 30.00 lg.) (eff. w/1977)
-	-	1	798359	TEE—spigot, drain (1/2" NPT male) (eff. w/1975) (prior to 1977)
-	-	1	2002228	COUPLING—water inlet tube (eff. w/serial No. 6V100878) (prior to 1977)

FURNISHINGS

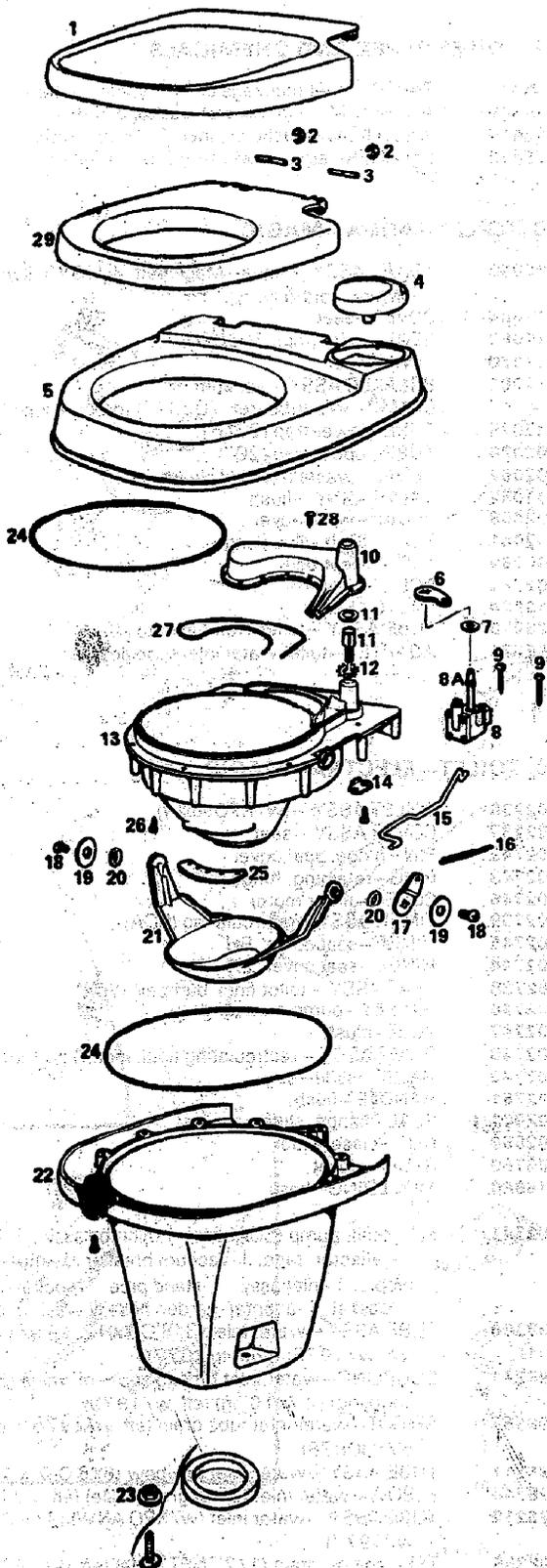

28.070H AQUA-MAGIC III TOILET
(SECOND DESIGN)

FURNISHINGS

KEY . 230 260 PART NUMBER

28.070H TOILET—AQUA-MAGIC

—	—	1	2006651	TOILET ASSY.—aqua magic III (eff. w/ 1976 & 1977)
1	—	1	2029250	COVER—seat
2	—	2	2029249	RETAINER pin
3	—	2	2029248	PIN—hinge
4	—	1	2029242	KNOB ASSY.—flush (SOA)
5	—	1	2029251	TOP—toilet
6	—	1	2029256	CRANK—knob
7	—	1	2029254	RETAINER—valve stem
8	—	1	2029244	VALVE ASSY.—ball
8A	—	1	2029255	O RING—valve to bowl
9	—	2	2029253	SCREW—valve
10	—	1	2029270	COVER—vacuum breaker
11	—	1	2029245	FLOAT ASSY.—toilet (SOA)
12	—	1	2029274	WASHER—float star
13	—	1	2029258	BOWL—toilet
14	—	1	2029276	BRACKET—spring mounting
15	—	1	2029277	LINK—push
16	—	1	2029275	SPRING—toilet
17	—	1	2029262	CRANK—water trap
18	—	2	2029263	SCREW—water trap crank
19	—	2	2029264	WASHER—water trap crank
20	—	2	2029265	SEAL—water trap crank
21	—	1	2029260	TRAP—water
22	—	1	2029267	BASE—toilet
23	—	1	2029269	MOUNTING PKG.—toilet base (mounting pkg. incl. 1-702061 seal, & 2-702069 nut.)
24	—	1	2029257	SEALANT—toilet top
25	—	1	NS	SEAL—trap (ref. 2029261)
26	—	9	2029259	SCREW—toilet
27	—	1	2029271	SEAL—cover
28	—	AR	2029268	SCREW—base
29	—	1	2029246	SEAT—toilet

FURNISHINGS

KEY 230 260 PART NUMBER

28.072 SWEEPER—VACUUM

—	—	2	718070	PIPE—pvc (type II) (1974)
—	—	1	718071	BARRIER—terminal block (1974)
1	—	1	706104	CORD ASSY.—line
2	—	1	NPN	CONNECTOR—strain relief
3	—	1	706110	BUSHING—terminal, low voltage
4	—	1	NPN	CABINET ASSY.
5	—	1	718064	ELBOW—(2", 90 degrees)
6	—	1	718065	GROMMET
7	—	4	—	SPEED NUT—cover plate (No. 6—32) (procure locally)
8	—	4	—	SPEED NUT—low voltage bracket (No. 10—24) (procure locally)
9	—	1	718066	PIPE—filter
10	—	4	—	SCREW—mounting (No. 10—16 x 1/2) (procure locally)
11	—	4	—	WASHER—mounting (procure locally)
12	—	3	—	NUT—hex (No. 6—32) (procure locally)
13	—	1	NPN	BRACKET—low voltage
14	—	1	706111	STIFFENER—filter
15	—	1	706112	FILTER—secondary
16	—	4	—	SCREW—low voltage bracket (No. 10—24 x 3/8) (procure locally)
17	—	1	706107	TRANSFORMER
18	—	1	706106	RELAY
19	—	3	—	SCREW—pan head (No. 6—32 x 5/8) (procure locally)
20	—	1	718067	SEAL—motor
21	—	1	—	SCREW—motor (procure locally)
22	—	1	—	WASHER—motor screw (procure locally)
23	—	1	706105	MOTOR ASSY.
24	—	1	NPN	BUSHING—snap (1/4 x 15/32)
25	—	1	NPN	DUCT—motor (SOA)
26	—	1	NPN	PLATE—cover
27	—	4	—	SCREW—cover plate (No. 6—32 x 1/2) (procure locally)
28	—	1	718069	KNOB—door
29	—	2	—	WASHER—door knob (procure locally)
30	—	1	NPN	NUT—push
31	—	1	NPN	PIN—roll
32	—	1	718068	DOOR
33	—	1	706109	BAG PACKAGE—filtering (4 per package)
34	—	2	—	SCREW—inlet, Phillips oval head (No. 10 x 1—5/8) (procure locally)
35	—	1	706108	INLET—low voltage
36	—	1	706113	GASKET—flange ell to inlet
37	—	1	706114	ELL—flange
38	—	4	—	SCREW—flange ell (No. 7—19 x 3/4) (procure locally)
39	—	1	706115	HOSE—flexible (13" long, 2" I.D.)
—	—	1	2234659	VACUUM
—	—	1	2234660	TOOL KIT(Complete)
—	—	1	2234661	HOSE

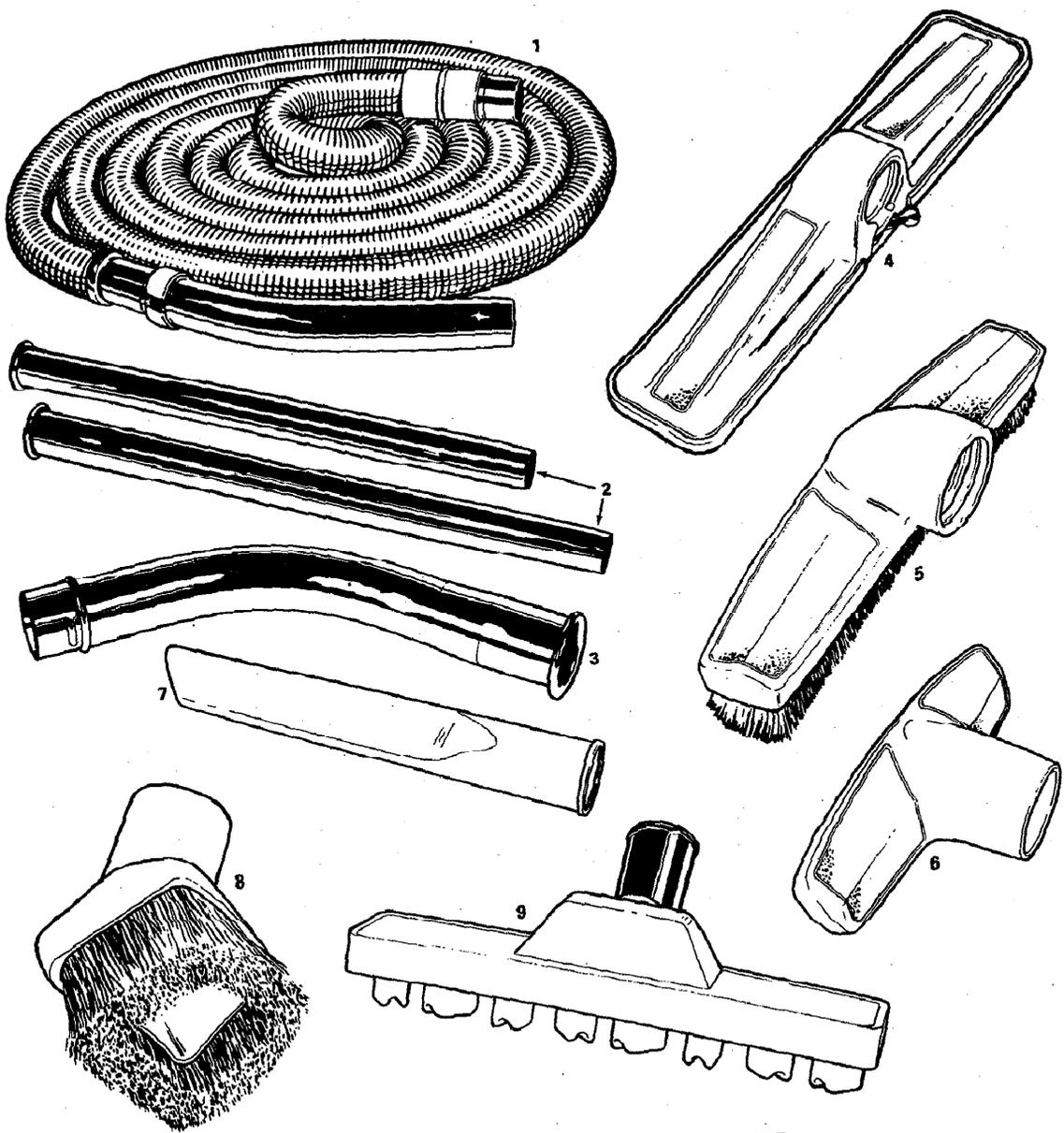

28.073 ATTACHMENTS - VACUUM SWEEPER

28.073 ATTACHMENTS—VACUUM SWEEPER

1	—	1	706116	HOSE—vacuum cleaner (Part of 2234661 kit)
2	—	1	706117	WAND SET—steel chrome plate (2 pc.)
3	—	1	706118	CONNECTOR—wand to tool set
4	—	1	706119	NOZZLE—carpet
5	—	1	706120	BRUSH—floor and wall (9")
6	—	1	706121	TOOL—upholstery
7	—	1	706122	TOOL—crevice
8	—	1	706123	TOOL—dusting
9	—	1	706124	TOOL—shag rug
—	—	1	717063	CADDY—tool storage

FURNISHINGS

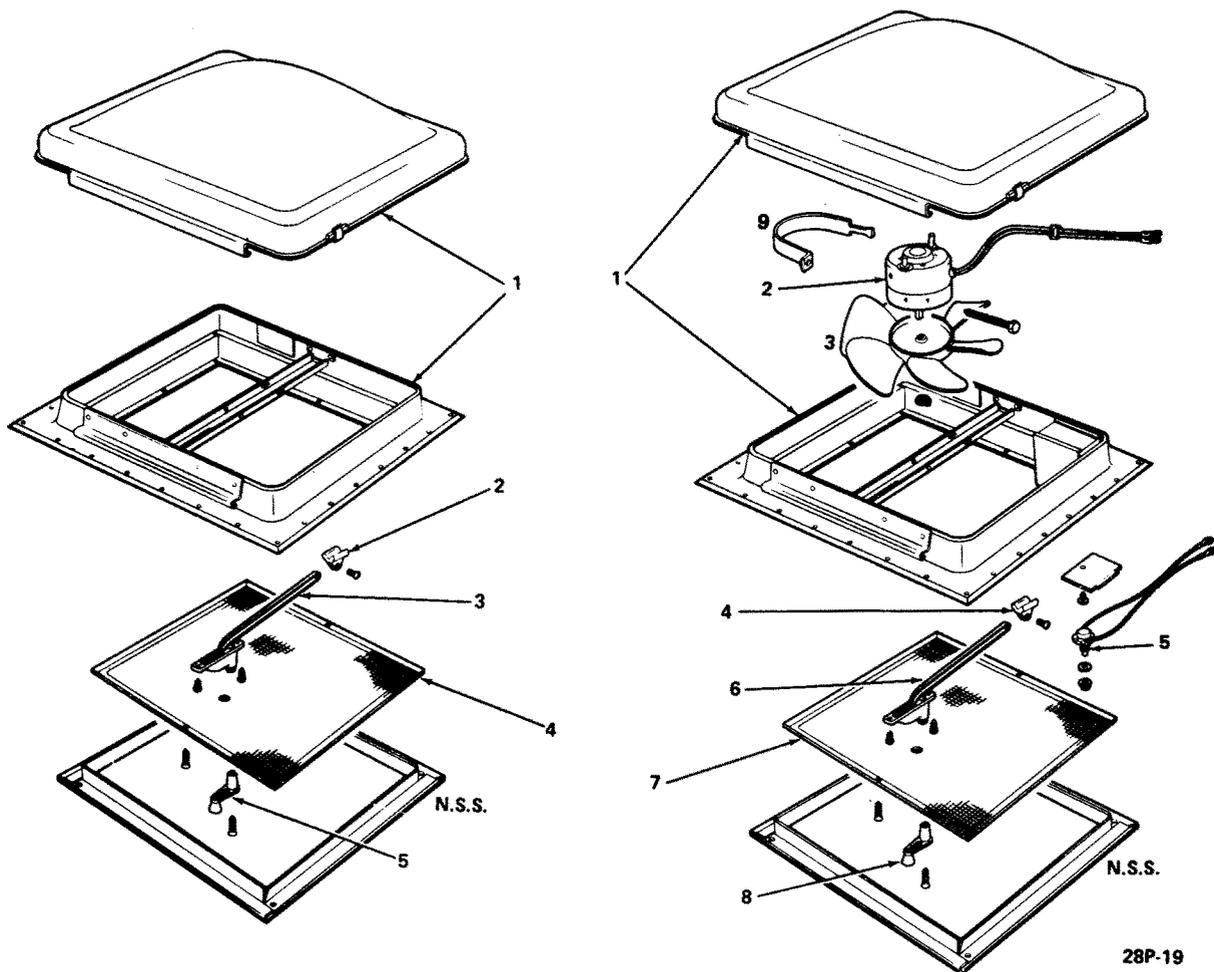

28P-19

KEY 230 260 PART NUMBER

28.074 VENT—NON—POWER ROOF

—	1	1	708369	NON—POWER ROOF VENT ASSY.—(prior to 1975) (incl. next (5) items)
1	1	1	708371	DOME AND COVER ASSY.—(SOA)
2	1	1	708373	SLIDE AND SCREW ASSY.—operator (SOA)
3	1	1	708374	OPERATOR ASSY.—crank (SOA)
4	1	1	708372	SCREEN ASSY.—(SOA)
5	1	1	708375	CRANK
—	—	2	2234633	NON—POWER ROOF VENT ASSY.—(off white), (repl. 720131) (eff. w/1975) (1st Design) (SOA)
—	—	2	2005297	NON—POWER ROOF VENT ASSY.—(white), (eff. w/1975) (2nd Design) (incl. next (2) items)
—	—	1	798050	COVER ASSY.—ceiling
—	—	1	798057	GASKET ASSY.—ceiling
—	—	2	2005296	FRAME ASSY.—vent screen (white) (w/2005297 vent assy.)
—	—	4	2005290	CRANK ASSY.—vent (white) (w/2005297 vent assy.)

28.074A VENT—POWER ROOF (PRIOR TO 1975)

—	1	1	708370	VENT ASSY.—power, ceiling (complete) (incl. next (9) items)
1	1	1	708371	DOME AND COVER ASSY.—(SOA)
2	1	1	705463	MOTOR ASSY.—(SOA)
3	1	1	705464	BLADE—fan
4	1	1	708373	SLIDE AND SCREW ASSY.—operator (SOA)

FURNISHINGS

KEY 230 260 PART NUMBER

28.074A VENT—POWER ROOF (PRIOR TO 1975) (Cont.)

5	1	1	705465	SWITCH ASSY.—(SOA)
6	1	1	708374	OPERATOR ASSY.—crank (SOA) (repl. 708379)
7	1	1	708376	SCREEN ASSY.—(SOA)
8	1	1	708380	CRANK
9	1	1	2009041	BRACKET—motor mount

FURNISHINGS

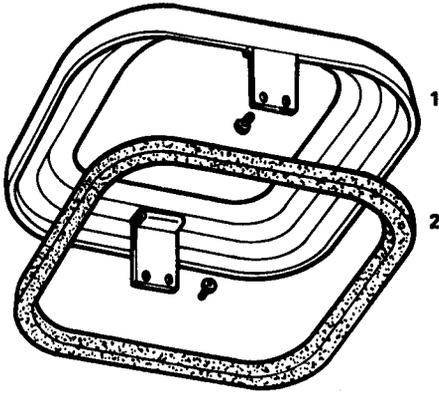

● N. S.

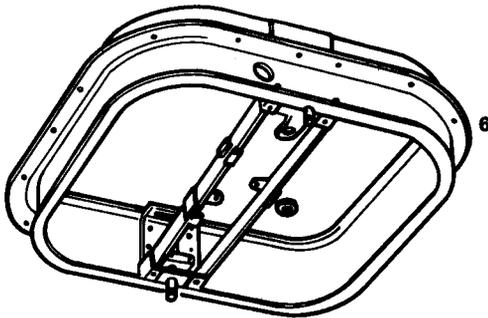
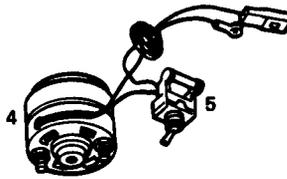
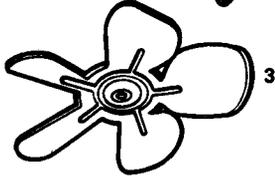

● ● N. S.

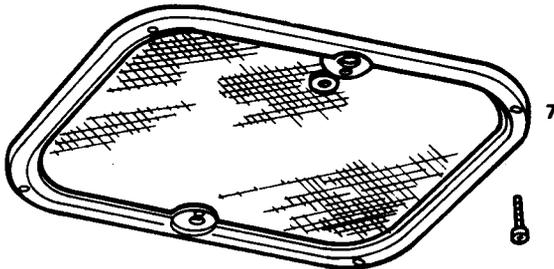

28.074B VENT - POWER ROOF (EFF. W/1975)

FURNISHINGS

KEY 230 260 PART NUMBER

28.074B VENT—POWER ROOF (EFF. w/1975)

—	—	2	790842	VENT ASSY.—power, ceiling (off white) (1st Design)
—	—	1	2005298	VENT ASSY.—power, ceiling (white) (complete) (2nd Design) (Note: above (2) vent assemblies include the following items as indicated)
1	—	1	798050	COVER ASSY.—power, ceiling (incl. gasket) (SOA) (w/790842 & 2005298 vent assy.)
2	—	1	798057	GASKET—cover (w/790842 & 2005298 vent assy.)
3	—	1	798056	BLADE—fan (9") (w/790842, & 2005298 vent assy.)
4	—	1	798051	MOTOR ASSY.—vent (SOA) (w/790842 & 2005298 vent assy.)
5	—	1	798055	SWITCH ASSY.—motor (SOA) (w/790842 & 2005298 vent assy.)
6	—	1	798052	FRAME ASSY.—vent (SOA) (w/790842 vent assy.)
7	—	1	798053	SCREEN FRAME ASSY.—vent (SOA) (w/798052 vent assy.)
8	—	2	798054	CRANK ASSY.—vent (incl. screws) (w/798052 vent assy.)
—	—	8	791036	SUPPORT—vent
—	—	1	2000390	FRAME ASSY.—vent screen (white) (this item is not a part of vent assy. 2005298)

FURNISHINGS

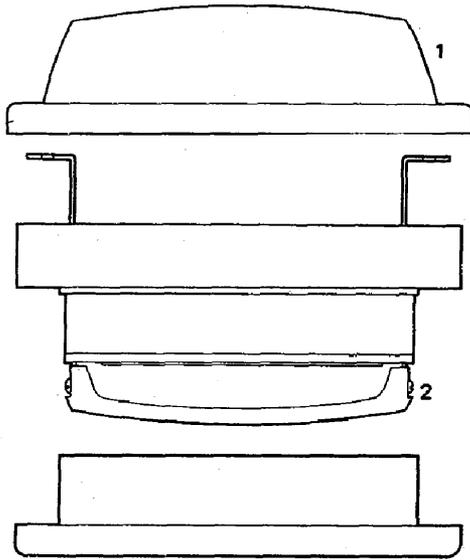

KEY 230 260 PART NUMBER

28.075 VENT — BATH, NON POWER

—	1	1	704838	VENT ASSY.—bath, non-power
1	1	1	704839	COVER—bath, non-power vent
2	1	1	2003730	HANDLE ASSY.—vent

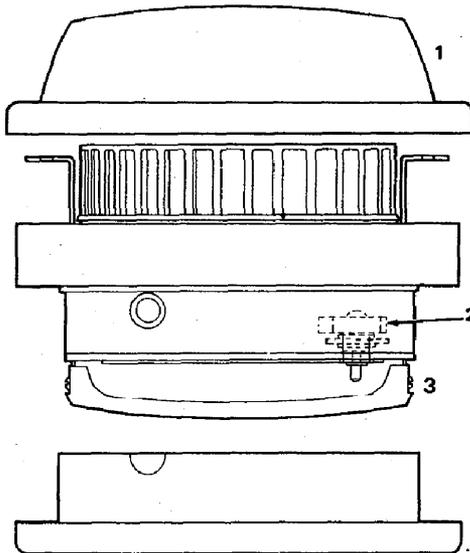

3P-14013

KEY 230 260 PART NUMBER

28.075A VENT—BATH POWER

—	1	1	704840	VENT ASSY. bath power
1	1	1	704841	COVER—bath power vent
2	1	1	704842	SWITCH—motor, bath power vent
—	—	6	9436816	RIVET—bath vent to roof panel
3	1	1	2003730	HANDLE ASSY.—vent

FURNISHINGS

NOTES

FURNISHINGS

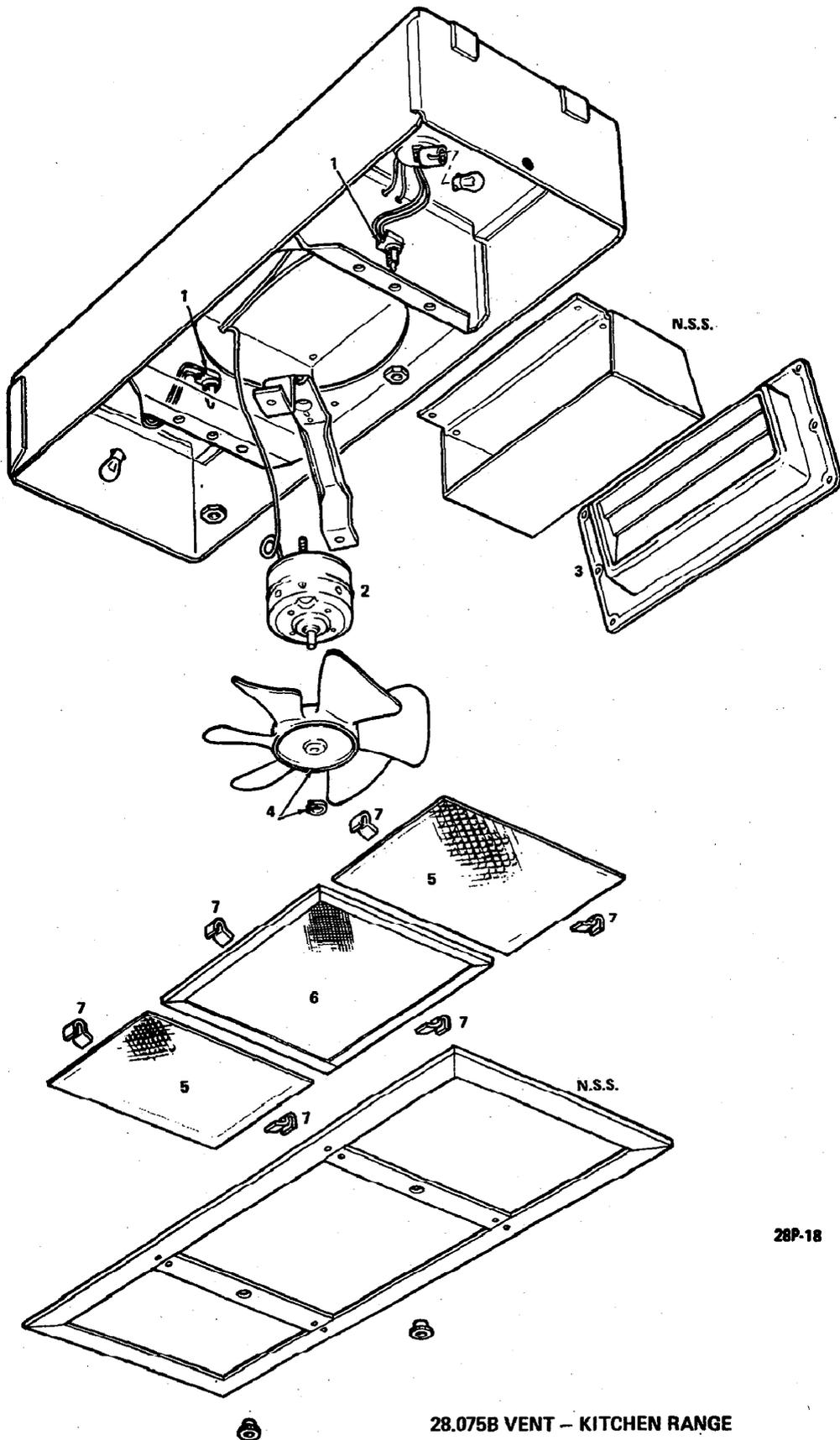

28P-18

28.075B VENT - KITCHEN RANGE

FURNISHINGS

KEY 230 260 PART NUMBER

28.075B VENT—KITCHEN RANGE

—	1	1	705460	VENT ASSY.—power, range (prior to 1975)
—	—	1	791177	LAMP AND VENT ASSY.—power, range (eff. w/1975)
1	2	2	705465	SWITCH—power motor (w/705460)
1	—	2	792812	SWITCH ASSY.—power motor (w/791177) (SOA)
2	1	1	705463	MOTOR—power (12 volt)
3	1	1	705466	LOUVRE—outside (repl. 792814)(w/705460, 791177)
4	—	1	792813	BLADE—fan, power motor (w/791177)
4	1	1	705464	BLADE—fan, power motor (w/705460)
5	2	2	705462	DIFFUSER—vent
6	1	1	705461	FILTER—vent
7	6	6	705467	CLIP—spring
—	—	1	792811	FRAME ASSY.—hood, vent (incl. diffuser and filter) (w/791177)
—	1	1	791689	TAG—range vent and do not cook
—	—	1	NPN	SHIELD—vent, galley (eff. w/1975) (ref. 2000270) (make locally)

FURNISHINGS

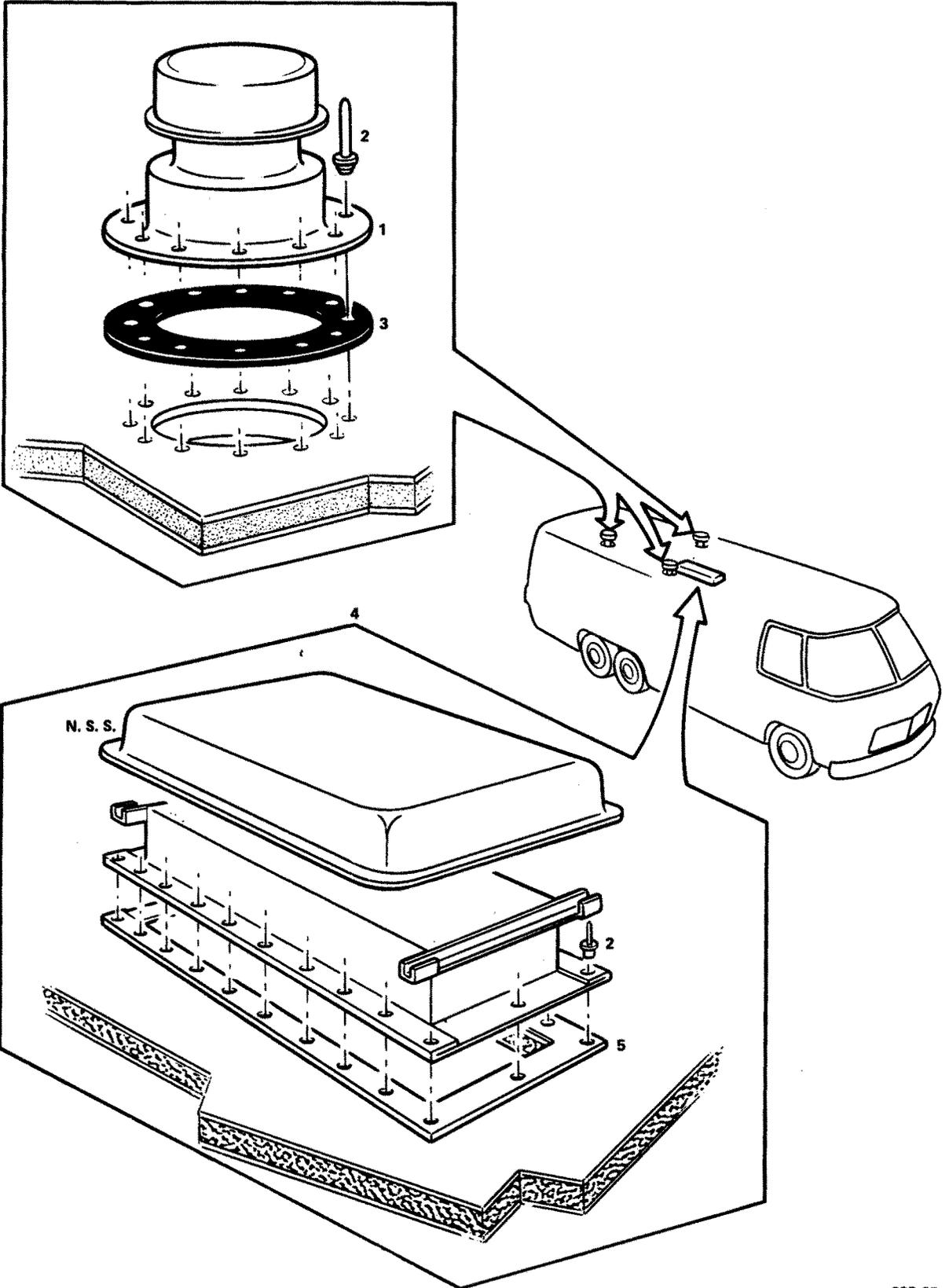

N. S. S.

FURNISHINGS

KEY 230 260 PART NUMBER

28.077 VENTS—PLUMBING & REFRIGERATION

1	2	3	718499	VENT ASSY.—sanitary plumbing (white) (SOA) (prior to 1975)
1	—	3	790369	VENT ASSY.—sanitary plumbing (white) (eff. w/1975)
2	—	AR	9436816	RIVET—vent (w/790369 vent)
2	—	30	792864	RIVET—vent (w/792853 vent)
3	—	3	790087	GASKET—vent (w/790369)
3	2	3	718786	GASKET—vent (w/718499)
4	1	1	NPN	VENT ASSY.—refrigerator (prior to 1975)
4	—	1	792853	VENT ASSY.—refrigerator (eff. w/1975) (details not available at time of publication)
5	—	AR	—	TAPE—vent (to roof) (65') (ref. only) (procure locally) (repl. 8861174)
6	2	3	2000394	CAP—vent, roof (w/790369)
—	—	1	—	VENT ASSY.—refrigerator side (door asm) (see grp. 23.025)
—	—	1	2027496	VENT KIT—furnace (1978)

FURNISHINGS

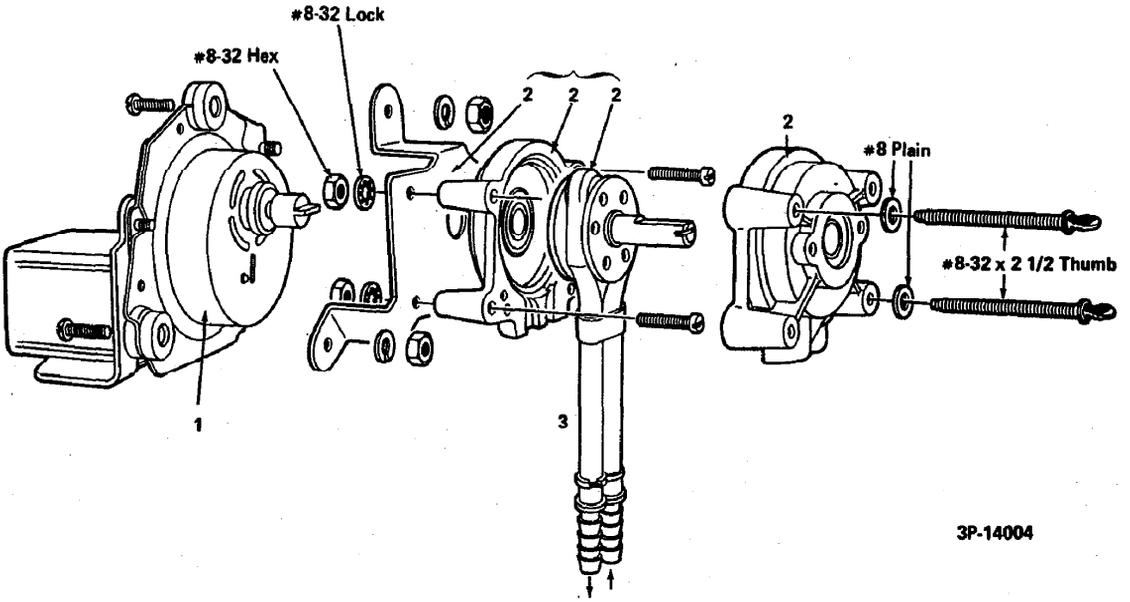

3P-14004

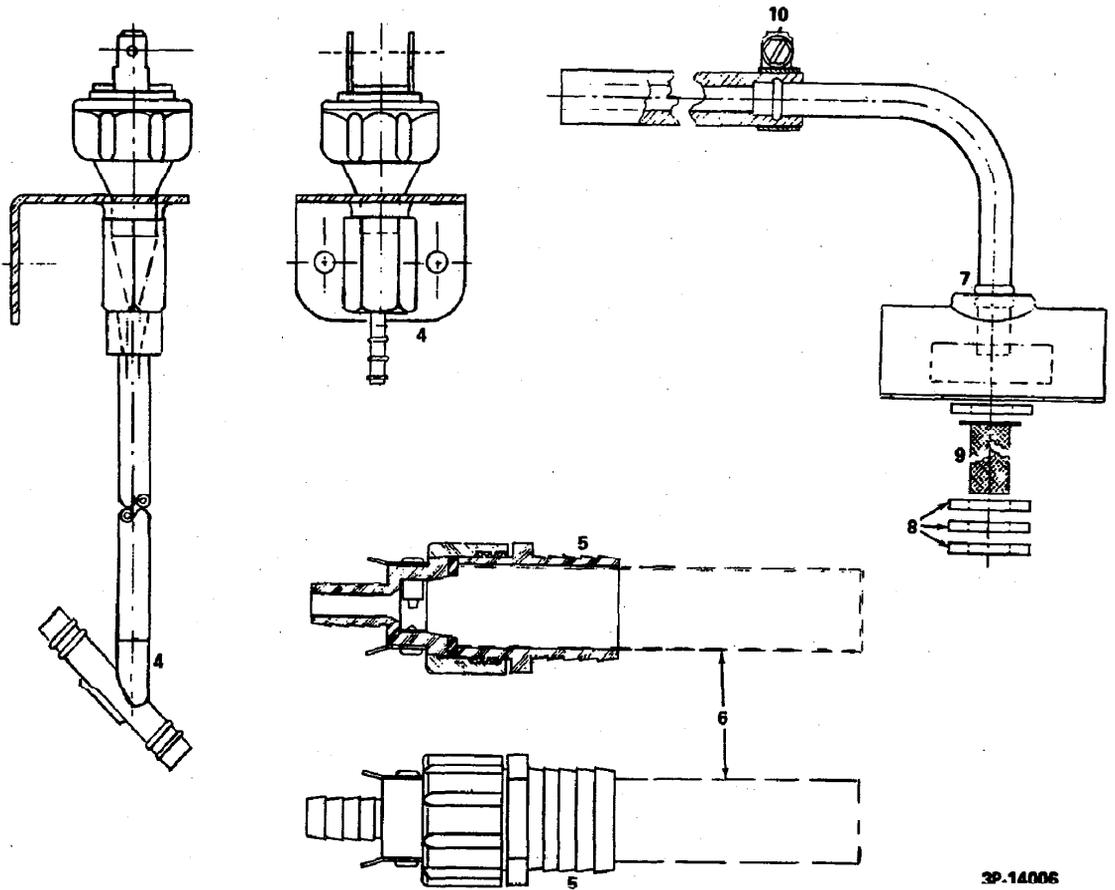

3P-14006

28.078 DISPOSAL - WASTE

FURNISHINGS

KEY 230 260 PART NUMBER

28.078 DISPOSAL—WASTE

—	1	1	705119	DISPOSAL ASSY.—waste (complete)
—	1	1	705121	INJECTION ASSY.—metering (incl. pump and motor)
1	1	1	705129	MOTOR ASSY.—(SOA)
2	1	1	705122	PUMP ASSY.—(incl. hose and non—serviced brkt.) (part of 705121 injection assy.)
3	1	1	705124	HOSE—pump (part of 705122 pump assy.)
4	1	1	705125	SENSOR ASSY.—heat (SOA)
5	1	1	719678	PROBE ASSY.—evacuation (incl. grommet, screen & washer) (at tank) (repl. 705130)
6	1	1	719679	SCREEN ASSY.—probe (part of 719678 probe) (repl. 705136)
7	1	1	705131	SANIJECTOR ASSY.—(incl. clamp, hose, screen, spring & gasket pkg.)
8	1	1	705141	PACKAGE—gasket, sanijector (part of 705131 sanijector assy.)
9	1	1	705143	SCREEN—sanijector (part of 705131 sanijector assy.) (at exhaust)
10	1	1	705146	CLAMP—hose, sanijector (part of 705131 sanijector assy.)
—	1	1	705144	GROMMET—holding tank (part of 719678 probe assy.)
—	2	2	705145	WASHER—rubber, holding tank (part of 719678 probe assy.)
—	1	1	705138	HOSE—pump to sanijector (red) (part of 705131 sanijector assy.)
—	1	1	705137	SPRING—hose protection (part of 705131 sanijector assy.)
—	1	1	705128	CENTER ASSY.—control
—	1	1	705132	LIGHT—ready—green (part of 705128 control assy.)
—	1	1	705133	LIGHT—reaction—red (part of 705128 control assy.)
—	1	1	705134	LIGHT—empty—white (part of 705128 control assy.)
—	1	1	705139	BASE—mounting, control center (part of 705128 control assy.)
—	1	1	705140	KNOB—control (part of 705128 control assy.)
—	1	1	705127	SENSOR ASSY.—tank level (SOA)
—	1	1	705135	HARNESS ASSY.—disposal (SOA)
—	1	1	705126	HARNESS ASSY.—speed sensor (SOA)
—	1	1	705142	HOSE—PVC, holding tank to pump
—	1	1	705123	SENSOR ASSY.—speed switch (SOA)
—	1	1	2017118	KIT—adapter, evacuation probe (incl. next (5) items)
—	1	1	705145	SEAL—adapter large
—	1	1	2017121	SEAL—adapter small
—	1	1	2017122	SCREEN—adapter
—	1	1	8884900	TUBING—nylon (25 ft. service)
—	1	1	2017120	CONNECTOR—twin tab

FURNISHINGS

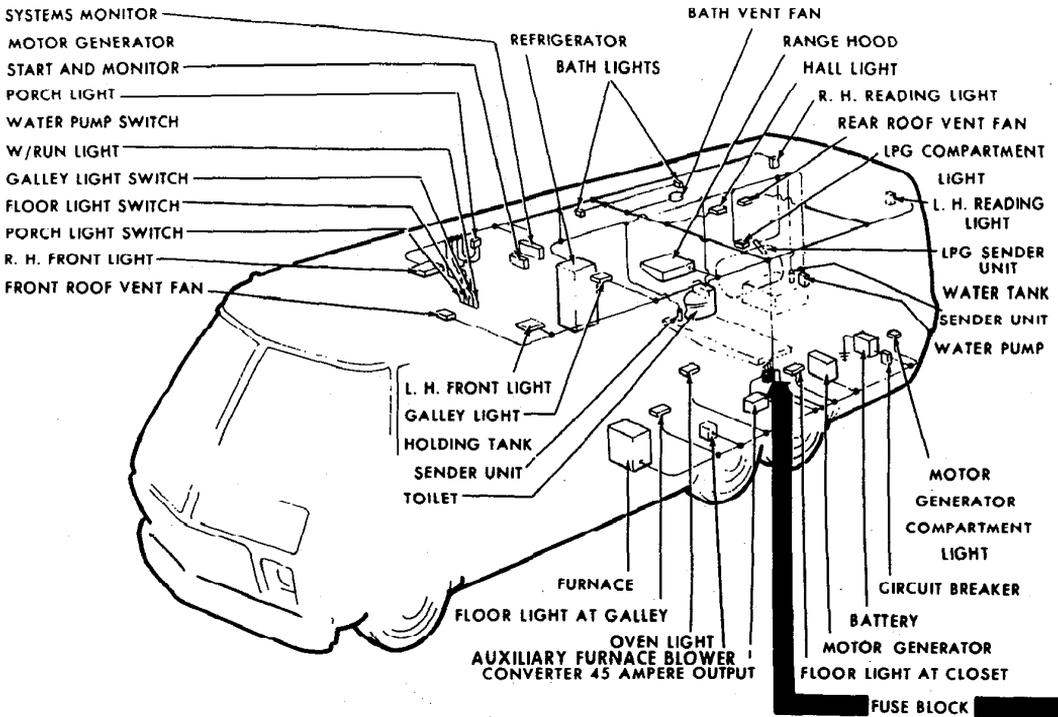

#7 FURNACE 6.80A., FURNACE AUXILIARY BLOWER 3.00A., MOTOR GENERATOR COMPARTMENT LIGHT 1.44A., OVEN LIGHT 1.44A., TOTAL 12.68AMP.

#6 RECIRC. TOILET 7.0A., TOTAL 7.0AMP.

#5 R.H. FRONT LIGHT 2.88A., BATH LIGHT 8.64A., REAR R.H. READING LIGHT 1.50A., TOTAL 13.0AMP.

#4 REFRIGERATOR 6.00A., HALL LIGHT 2.88A., LPG COMPARTMENT LIGHT 1.44A., TOTAL 10.32 AMP.

#3 PORCH LIGHT 1.44A., FLOOR LIGHT 1.18A., GALLEY LIGHT 2.88A., WATER PUMP 3.60A., SYSTEMS MONITOR 2.50A., TOTAL 11.60AMP.

#2 RANGE HOOD FAN AND RANGE HOOD LIGHTS 6.70A., BATH ROOF VENT FAN 3.50A., REAR L.H. READING LIGHT 1.50A., TOTAL 11.70 AMP.

#1 L.H. FRONT LIGHT 2.88A., FRONT ROOF VENT FAN 3.50A., GALLEY LIGHT 2.88A., REAR ROOF VENT FAN 3.50A., TOTAL 12.76 AMP.

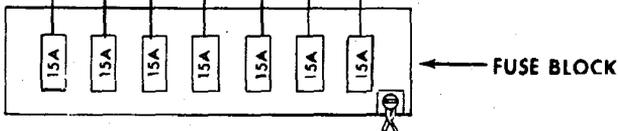

FURNISHINGS

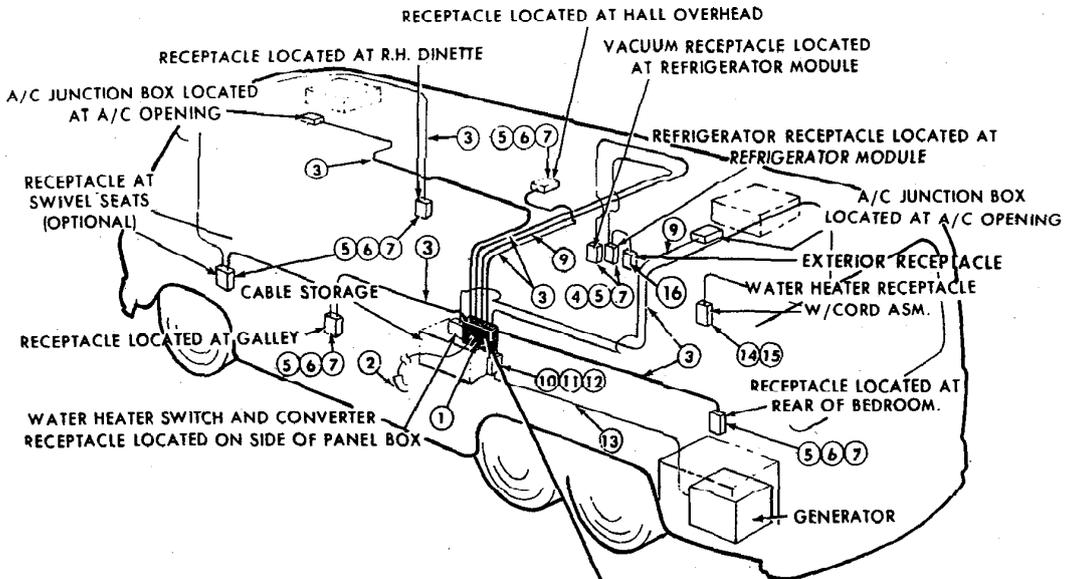

ITEM NO	PART NAME
1	MAIN PANEL BOX
2	#8-4 WIRE CORD TYPE '50' W/PLUG
3	WIRE 12/2 W/GROUND WIRE
4	SINGLE RECEPTACLE
5	OUTLET BOX
6	DUPLEX RECEPTACLE
7	OUTLET PLATE
8	SWITCH & RECEPTACLE
9	14/2 W/GROUND WIRE
10	3 POLE 4 WIRE RECEPTACLE
11	OUTLET BOX
12	OUTLET PLATE
13	#6-2 WIRE CORD IN METAL CONDUIT
14	'J' BOX
15	BLANK COVER PLATE
16	EXTERIOR RECEPTACLE

CIRCUIT BREAKER PANEL				
CIRCUIT #1	CIRCUIT #2	CIRCUIT #3	CIRCUIT #4	CIRCUIT #5
FRONT AIR COND. RECEPT.	WATER HEATER RECEPT.	HALL OVER RECEPT.	VACUUM RECEPT.	REAR AIR COND. RECEPT.
	CONVERTER RECEPT.	BEDROOM RECEPT.		
		GALLEY RECEPT.		
		SWIVEL CHAIR RECEPT.(OPT.)		
		R.H. DINETTE RECEPT.		
		REFRIGERATOR RECEPT.		
		EXTERIOR RECEPT.		

FURNISHINGS

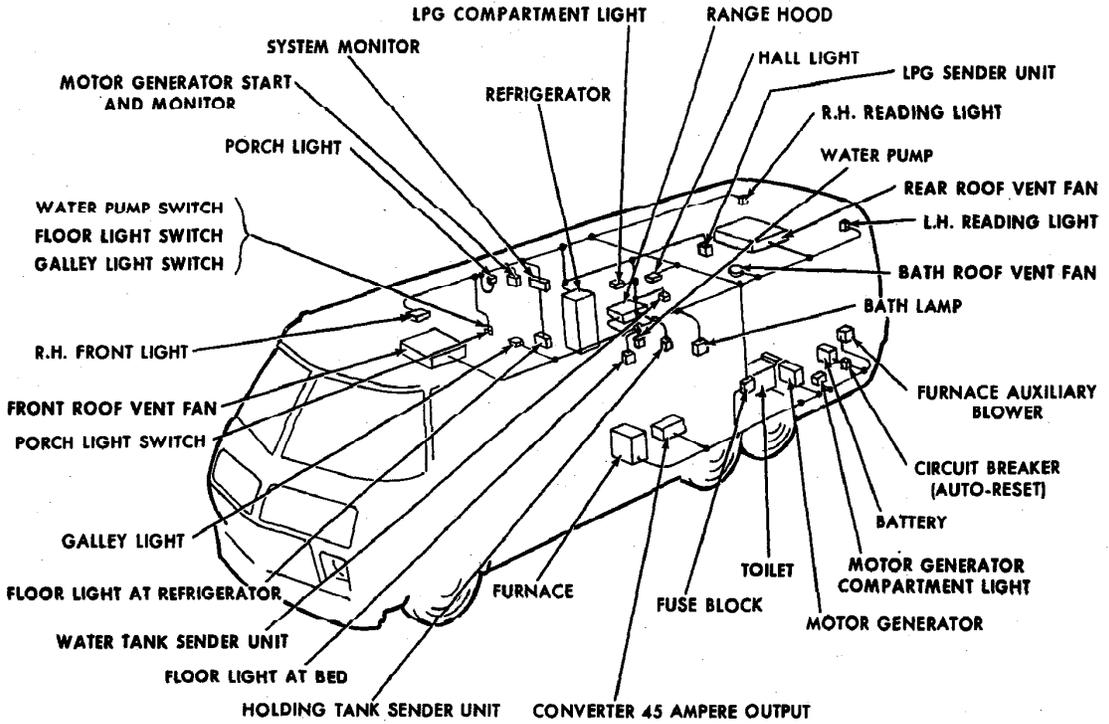

15A	#1	L.H. READING LIGHT 1.50A., REAR ROOF VENT FAN 3.50A., BATH ROOF VENT FAN 3.50A., GALLEY LIGHT 2.88A., TOTAL 11.38 AMP.
15A	#2	FRONT ROOF VENT FAN 3.50A., RANGE HOOD FAN AND LIGHTS 6.70A., HALL LIGHT 2.88A., TOTAL 13.08 AMP.
15A	#3	FURNACE 6.80A., FURNACE AUXILIARY BLOWER 3.00A., MOTOR GENERATOR COMPARTMENT LIGHT 1.44A., TOTAL 11.24 AMP.
15A	#4	REFRIGERATOR 5.00A., LPG COMPARTMENT LIGHT 1.44A., R.H. FRONT LIGHT 2.88A., TOTAL 9.32 AMP.
15A	#5	PORCH LIGHT 1.44A., FLOOR LIGHTS 1.18A., WATER PUMP 5.50A., TOTAL 8.12 AMP.
15A	#6	RECIRC. TOILET 7.00A., TOTAL 7.00 AMP.
15A	#7	R.H. READING LIGHT 1.50A., GALLEY LIGHT SWITCH 2.88A., BATH LIGHT 4.32A., SYSTEMS MONITOR 2.50A., TOTAL 11.20 AMP.

FURNISHINGS

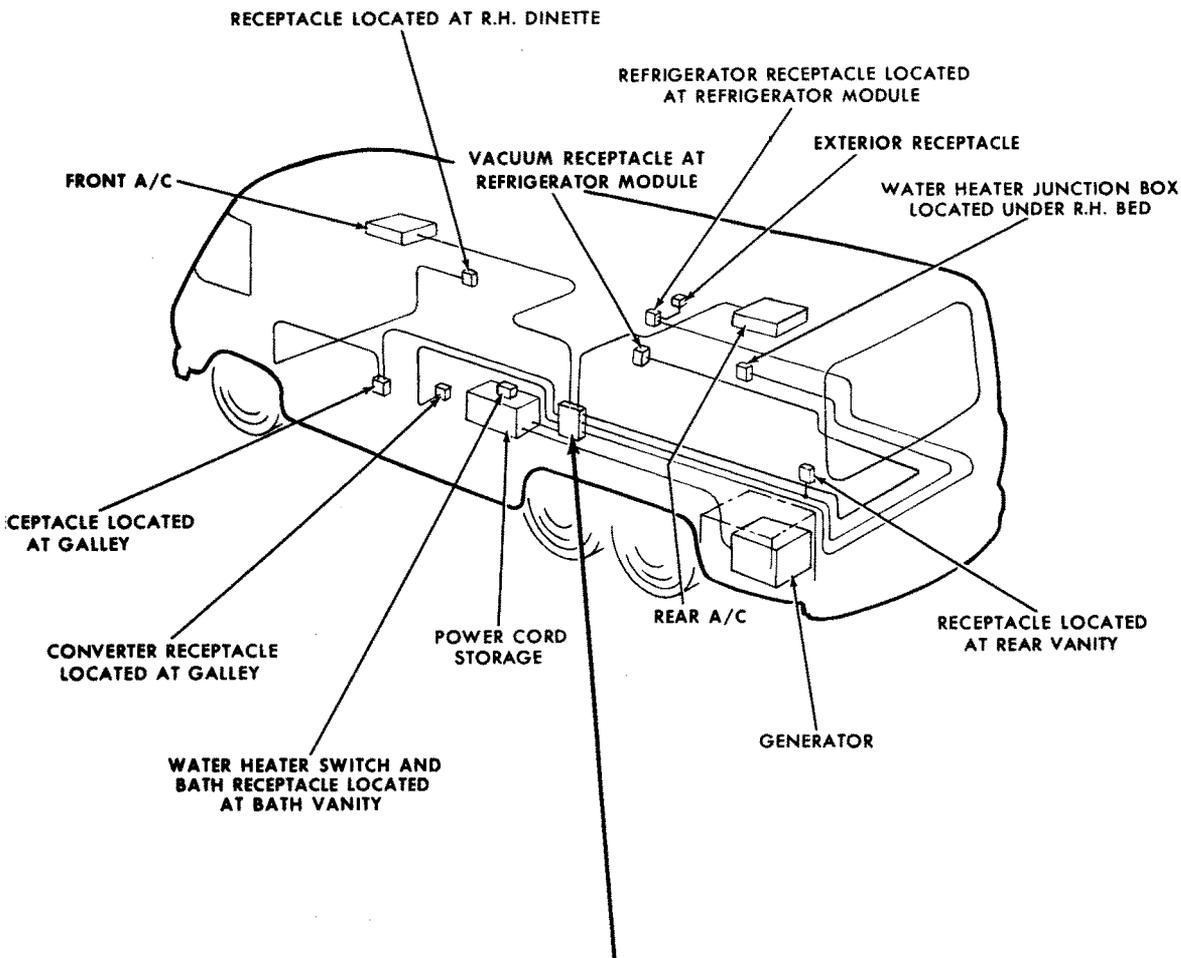

CIRCUIT BREAKER PANEL				
CIRCUIT #1	CIRCUIT #2	CIRCUIT #3	CIRCUIT #4	CIRCUIT #5
FRONT AIR COND. RECEPT.	WATER HEATER RECEPT.	GRD. FAULT PROTECTED BEDROOM RECEPT.	VACUUM RECEPT.	REAR AIR COND.
	CONVERTER RECEPT.	GALLEY RECEPT.		
		R.H. DINETTE RECEPT.		
		REFRIGERATOR RECEPT.		
		BATH RECEPT.		
		EXTERIOR RECEPT.		

FURNISHINGS

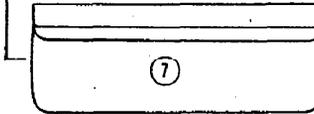
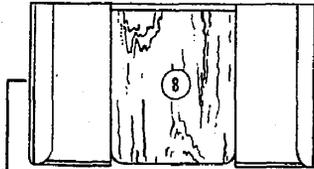
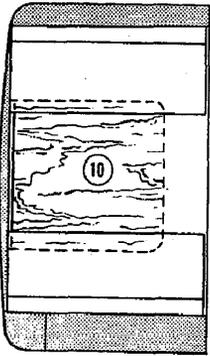
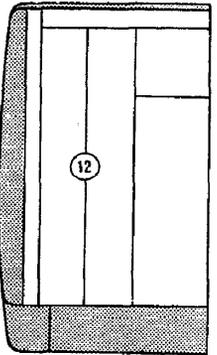
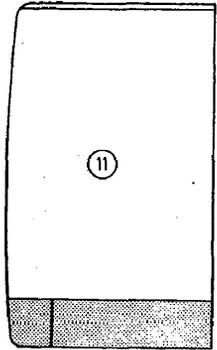
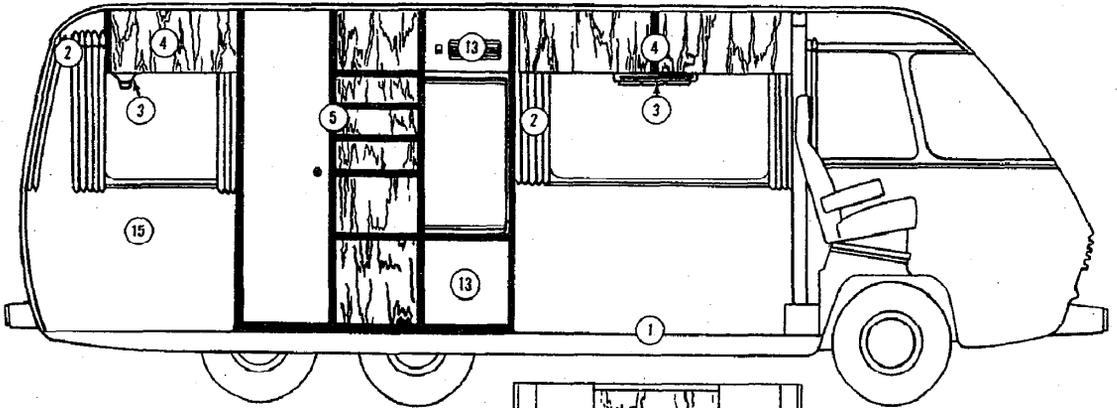

LH

Key	Description	Grp. No.
1	Carpeting	28.106
2	Drapes	28.110
3	Electrical	28.114
4	Overhead Cabinets	28.120
5	Clothes Closet	28.124
6	Galley	28.128
7	Davo/Bunk	28.132
8	Dinette/Double Bed	28.136
9	Drivers Comp. Table	28.148
10	Settee & Table	28.152
11	Permanent Bed	28.156
12	GaUCHO/Double Bed	28.160
13	Refrigerator Cabinet	28.168
14	Bathroom	28.172
15	Panels & Molding	28.176
-	Wood & Cushion Covering	28.180

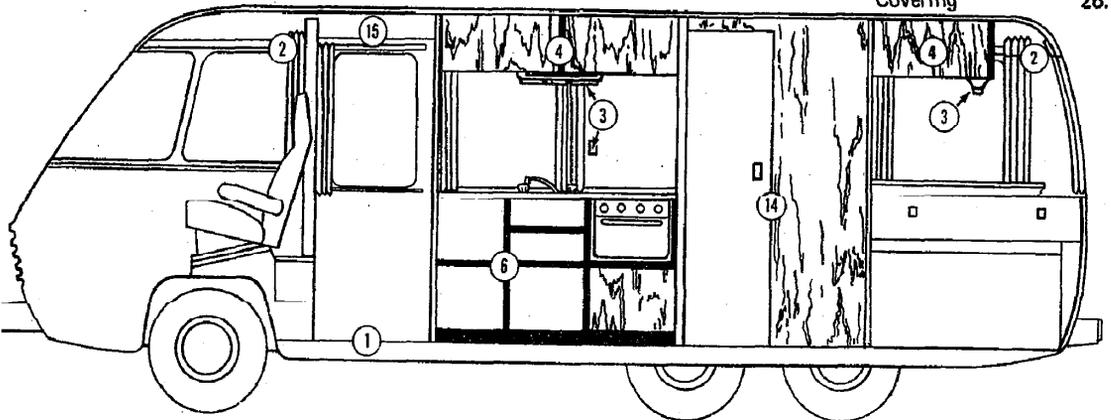

GMC MOTOR HOME 230

FURNISHINGS

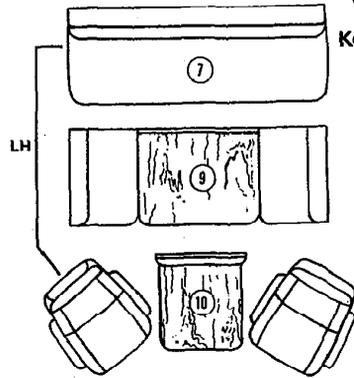
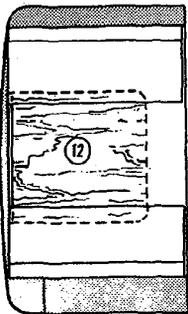
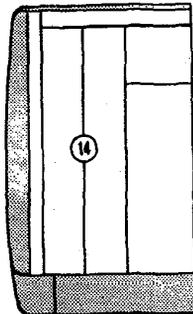
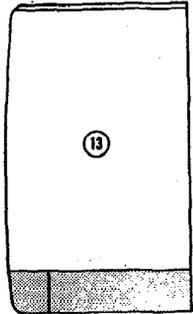
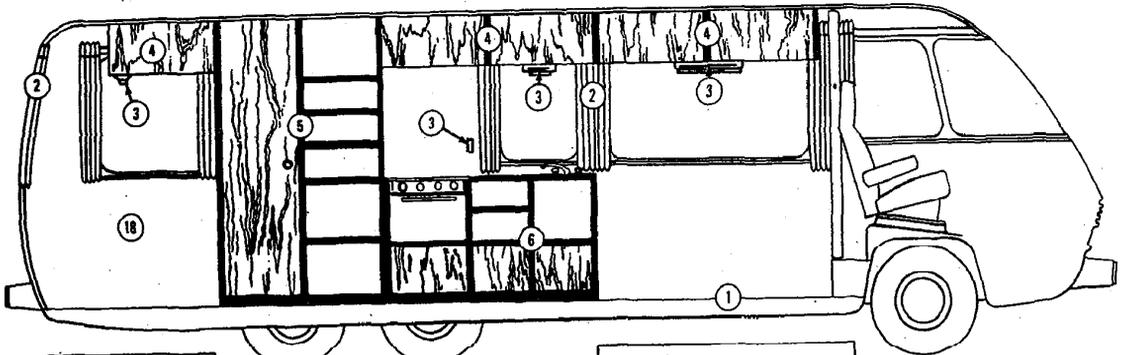

Key	Description	Group No.
1	Carpeting	28.106
2	Drapes	28.110
3	Electrical	28.114
4	Overhead Cabinets	28.120
5	Clothes Closet	28.124
6	Galley	28.128
7	Davo/Bunk	28.132
8	Dinette/Double Bed	28.136
9	Aux. Din./Single Bed	28.140
10	Lounge Seats & Table	28.144
11	Drivers Comp. Table	28.148
12	Sette & Table	28.152
13	Permanent Bed	28.156
14	Gacho/Double Bed	28.160
15	Broom/Vac. Closet	28.164
16	Refrigerator Cabinet	28.168
17	Bathroom	28.172
18	Panels & Molding	28.176

Key	Description	Group No.
-	Wood & Cushion Covering	28.180

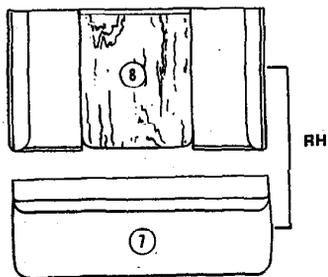
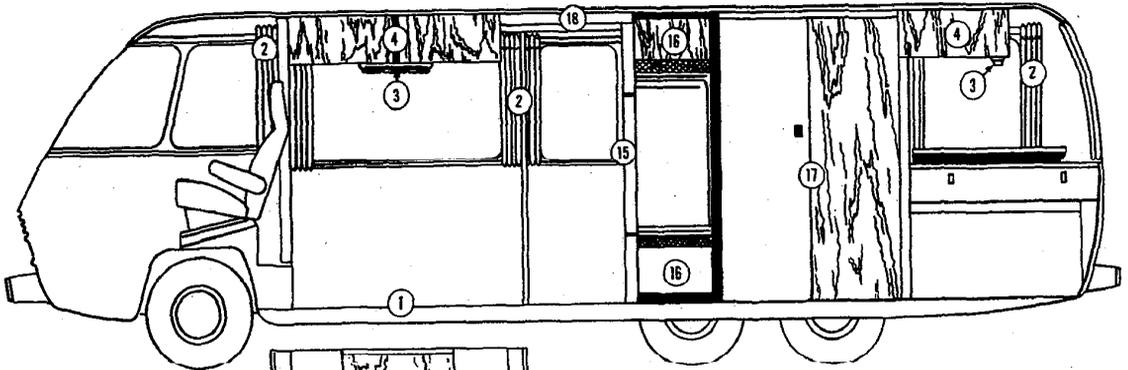

GMC MOTOR HOME 260

FURNISHINGS

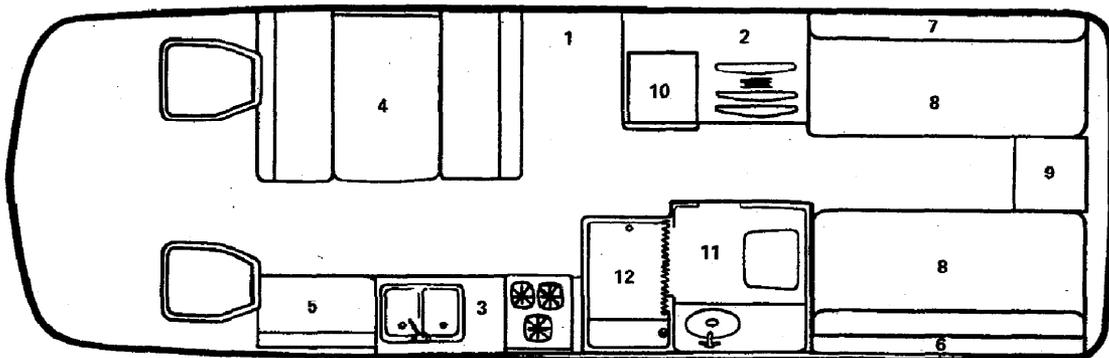

KEY	DESCRIPTION	GROUP NO.	KEY	DESCRIPTION	GROUP NO.
1	Carpeting	28.106	7	Bedding Locker	28.155
-	Overhead Cabinets	28.120	8	Twin-Bed	28.158
2	Closet Module	28.124	9	Rear Dresser	28.162
3	Galley Module	28.128	10	Refrigerator Module	28.168
4	Dinette/Double Bed	28.136	11	Bathroom Module	28.172
5	Love Seat	28.142	12	Shower	28.172
6	Heater Closure	28.154	-	Panels & Molding	28.176

28P-37-975

GMC MOTOR HOME
TWIN BED, DRY BATH
260 MODEL

FURNISHINGS

NOTES

FURNISHINGS

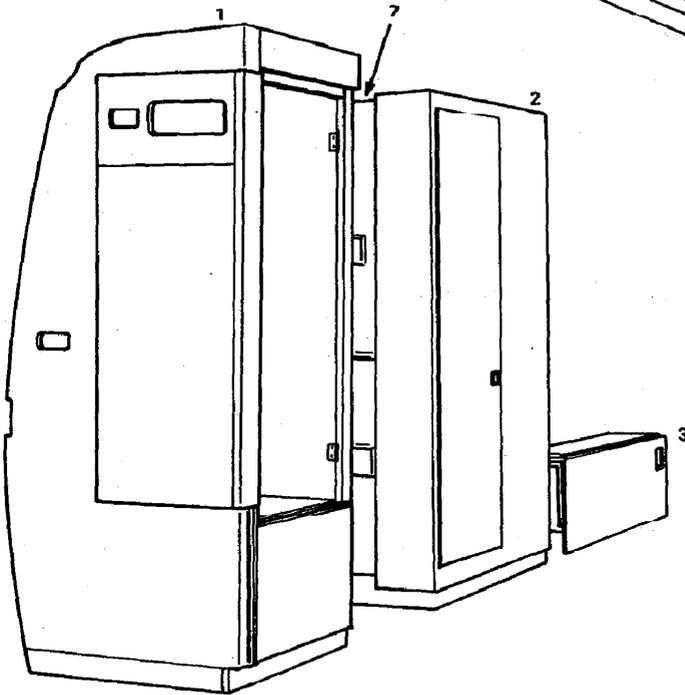
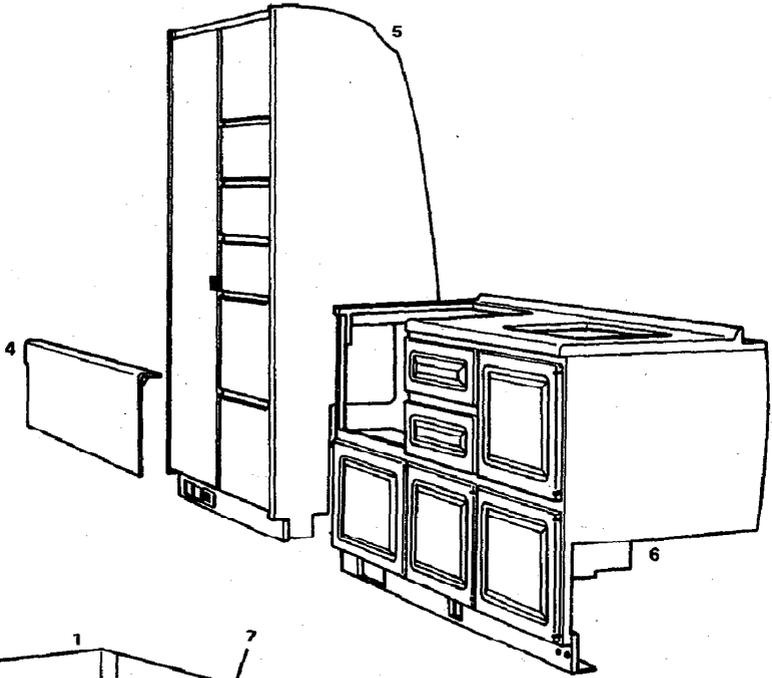

MOTORHOME MAJOR MODULES

FURNISHINGS

KEY 230 260 PART NUMBER

MOTORHOME MAJOR MODULES

KEY	DESCRIPTION	GROUP NO.
1	REFRIGERATOR MODULE	28.168
2	BATHROOM MODULE	28.172
3	BEDDING LOCKER	28.155
4	HEATER CLOSURE (TRIM PANEL)	28.154
5	CLOSET MODULE	28.124
6	GALLEY MODULE	28.128
7	BATHROOM MODULE INSERT	28.172

28.106 CARPETING

—	2	2	NS	CARPET—690 Sequoia (7' x 12') (procure locally) (ref. 717385)
—	2	2	NS	CARPET—692 Painted Desert (7' x 12') (repl. 715580, 716562) (procure locally)
—	2	2	NS	CARPET—693 Glacier (procure locally) (7' x 12') (repl. 715581, 716563) (ref. 717387)
—	2	2	NS	CARPET—695 Canyon Land (7' x 12') (repl. 715582, 716564) (procure locally) (ref 717388)
—	—	2	723366	CARPET—Eleganza 1 (7' x 12')
—	—	AR	NS	CARPET—interior (681 Glenbrook, 697 Eleganza 11) (Mohawk No. (Natural Charmer) NTL—8, Burnished Brown) (procure locally) (w/out ZEO6584)
—	—	1	NS	CARPET—interior (w/RPO 698) Sweet Water No. 326—2072 Green (procure locally)
—	—	AR	NS	CARPET—interior (w/RPO 683) (sweet water No. 2232 spanish ocher) (ref. 8861529) (procure locally)
—	—	AR	NS	CARPET—interior (w/RPO 685) (sweet water No. 2135 lipstick) (procure locally)
—	—	AR	NS	CARPET—interior (sweet water No. 825 saffron) (w/RPO 641 & ZEO6584) (procure locally)
—	—	AR	NS	CARPET—interior (Mohawk—Natural Charmer) (w/RPO 697 & ZEO6584) (procure locally)
—	—	2	2001451	CARPET ASSY.—seat riser, (around driver and passenger seat pedestal) (w/RPO 698) (w/out ZEO6584)
—	—	2	NS	CARPET ASSY.—seat riser, (around driver and passenger seat pedestal) (w/RPO 685) (sweet water No. 2135 Lipstick)

28.110 DRAPES, SLIDES, STOPS, TRACKS

NOTE: When ordering Drapes, the quantity one [1] indicates 1 pair. (Except as noted).

—	—	1	2006770	DRAPE SET—complete (w/RPO 683) (ref. only) (*Note: does not incl. windshield drape)
—	—	1	793374	DRAPE SET—complete (w/RPO 681, 697) (prior to 1977) (ref. only)
—	—	1	2000928	DRAPE SET—complete (w/RPO 698) (prior to 1977) (ref. only)
—	—	1	2022736	DRAPE SET—complete (w/RPO 641, 697) (exc./ZEO6584) (eff. w/interm 1977) (prior to 1978) (ref. only) (pattern: edinberg natural) (fabric: lined - color fern beige)
—	—	1	2025187	DRAPE SET—complete (w/RPO 697) (w/ZEO6581) (1978)
—	—	1	2018589	DRAPE SET—complete (w/RPO 698) (exc./ZEO6584) (1977) (ref. only)
—	—	1	2029067	DRAPE SET—complete (w/RPO 698) (w/ZEO6581) (1978) (ref. only)
—	—	1	2027935	DRAPE SET—complete (w/RPO 685) (eff w/1977) (ref. only)
—	—	1	2022737	DRAPE SET—complete (w/RPO 641, 697 & ZEO6584) (ref. only) (pattern: edinberg natural) (fabric: lined-color fern beige)
—	—	1	2013072	DRAPE SET—complete (w/RPO 698 & ZEO6584) (eff. w/1977) (ref. only)
—	—	1	2018588	DRAPE SET—complete (w/RPO 697) (exc./ZEO6584) (prior to interm 1977) (pattern: grasscloth) (fabric: lined-color gold) (ref. only)
—	—	1	2013063	DRAPE SET—complete (w/RPO 697) (w/ZEO6584) (prior to interm 1977) (pattern: grasscloth) (fabric: lined-color gold) (ref. only)

FURNISHINGS

28.110 DRAPES, SLIDES, STOPS, TRACKS (Cont.)

*NOTE: There are no windshield drapes available for (RPO 683)

—	1	1	715174	DRAPE—windshield (w/RPO 690)
—	1	1	715181	DRAPE—windshield (w/RPO 692)
—	1	1	715188	DRAPE—windshield (w/RPO 693)
—	1	1	NS	DRAPE—windshield (w/RPO 695, 696)
—	—	1	795083	DRAPE—windshield (w/RPO 681, 697) (prior to 1977)
—	—	1	2027439	DRAPE—windshield (w/RPO 685) (Pattern: bonaire) (Fabric: lined - color ivory)
—	—	1	2003479	DRAPE—windshield (incl. drape glides) (w/RPO 698) (prior to 1977)
—	—	1	2029207	DRAPE—windshield (w/RPO 698) (1978)
—	—	1	2018240	DRAPE—windshield (w/RPO 698) (1977)
—	—	1	2018253	DRAPE—windshield (w/RPO 697) (prior to interm 1977) (pattern: grass cloth) (fabric: lined-color gold)
—	—	1	2022805	DRAPE—windshield (w/RPO 641 & 697) (pattern: edinberg natural) (fabric: lined-color fern beige)
—	—	1	2022803	DRAPE—front privacy/divider (incl. 1 pair tie backs) (w/RPO 641 & 697) (pattern: edinberg natural) (fabric: lined-color fern beige)
—	1	1	715175	DRAPE—front privacy/divider (w/RPO 690)
—	1	1	715182	DRAPE—front privacy/divider (w/RPO 692)
—	1	1	715189	DRAPE—front privacy/divider (w/RPO 693)
—	1	1	NS	DRAPE—front privacy/divider (w/RPO 695, 696)
—	1	1	2027438	DRAPE—front privacy/divider (w/RPO 685) (Pattern: bonaire) (Fabric: lined - color ivory) (incl. 1 pair tie backs)
—	—	1	2018239	DRAPE—front privacy/divider (incl. 1 pair tie backs) (w/RPO 698) (1977)
—	—	1	2029206	DRAPE—front privacy/divider (incl. 1 pair tie backs) (w/RPO 698) (1978)
—	—	1	2018252	DRAPE—front privacy/divider (incl. 1 pair tie backs) (w/RPO 697) (prior to interm 1977) (pattern: grass cloth) (fabric: lined-color gold)
—	—	1	795084	DRAPE—front privacy/divider (incl. 1 pair tie backs) (w/RPO 681, 697) (prior to 1977)
—	—	1	2003480	DRAPE—front privacy/divider (incl. 1 pair tie backs & drape glides) (w/RPO 698) (prior to 1977)
—	—	1	2009364	DRAPE—front privacy/divider (incl. 1 pair tie backs) (w/RPO 683)
—	—	2	2009373	DRAPE—front picture (living area) window (2 pair) (w/RPO 683)
—	—	2	2018245	DRAPE—front picture (living area) window (2 pair) (w/RPO 698) (1977)
—	—	1	2029071	DRAPE—front side window RH (living area) (woven wood) (w/RPO 698) (1978)
—	—	1	2029070	DRAPE—front side window LH (living area) (woven wood) (w/RPO 698) (1978)
—	—	2	2018256	DRAPE—front picture (living area) window (2 pair) (w/RPO 697) (prior to interm 1977) (pattern: grass cloth) (fabric: lined-color gold)
—	1	2	715177	DRAPE—front picture (living area) window (w/RPO 690)
—	1	2	715184	DRAPE—front picture (living area) window (w/RPO 692)
—	1	2	715191	DRAPE—front picture (living area) window (w/RPO 693)
—	1	2	NS	DRAPE—front picture (living area) window (w/RPO 695, 696)
—	—	2	795080	DRAPE—front picture (living area) window (w/RPO 681, 697) (prior to 1977)
—	—	2	2003474	DRAPE—front picture (living area) window (w/RPO 698) (prior to 1977)
—	—	1	2029068	DRAPE—front side window RH (living area) (woven wood) (w/RPO 685) (eff w/ 1977)
—	—	1	2027947	DRAPE—front side window LH (living area) (woven wood) (w/RPO 685) (eff w/ 1977)
—	—	1	2022816	DRAPE—front picture (living area) window (2 pair) (w/RPO 641 & 697) (pattern: edinberg natural) (fabric: lined-color fern beige)
—	—	1	2022818	DRAPE—entrance door window (w/RPO 641 & 697) (pattern: edinberg natural) (fabric: lined-color fern beige)
—	—	1	2003472	DRAPE—entrance door window (w/RPO 698) (prior to 1977)
—	—	1	795079	DRAPE—entrance door window (w/RPO 681, 697) (prior to 1977)
—	—	1	2009374	DRAPE—entrance door window (1 pair) (w/RPO 683)
—	—	1	2027440	DRAPE—entrance door window (w/RPO 685) (Pattern: bonaire) (Fabric: lined - color ivory)
—	—	1	2018246	DRAPE—entrance door window (w/RPO 698) (1977)
—	—	1	2029208	DRAPE—entrance door window (w/RPO 698) (1978)
—	—	1	2018257	DRAPE—entrance door window (w/RPO 697) (prior to interm 1977) (Pattern: grass cloth) (Fabric: lined - color gold)

FURNISHINGS

KEY 230 260 PART NUMBER

28.110 DRAPES, SLIDES, STOPS, TRACKS (Cont.)

—	1	1	719392	DRAPE PKG.—entrance door window (w/RPO 690) (incl. 2 curtains, snap fasteners and 2 tie backs) (repl. 715172)
—	1	1	719393	DRAPE PKG.—entrance door window (w/RPO 692) (incl. 2 curtains, snap fasteners and 2 tie backs) (repl. 715179)
—	1	1	719394	DRAPE PKG.—entrance door window (w/RPO 693) (incl. 2 curtains, snap fasteners and 2 tie backs) (ref. 719395) (repl. 715186)
—	1	1	NS	DRAPE PKG.—entrance door window (w/RPO 695) (incl. 2 curtains, snap fasteners and 2 tie backs) (repl. 715193)
—	—	1	2018258	DRAPE—galley window (w/RPO 697) (prior to interm 1977) (pattern: grasscloth) (fabric: lined-color gold)
—	—	1	2018247	DRAPE—galley window (w/RPO 698) (1977)
—	—	1	2029072	DRAPE—galley window (w/RPO 698) (woven wood) (1978)
—	1	1	715173	DRAPE—galley window (w/RPO 690)
—	1	1	715180	DRAPE—galley window (w/RPO 692)
—	1	1	715187	DRAPE—galley window (w/RPO 693)
—	1	1	NS	DRAPE—galley window (w/RPO 695, 696)
—	—	1	795078	DRAPE—galley window (w/RPO 681, 697) (prior to 1977)
—	—	1	2003471	DRAPE—galley window (w/RPO 698) (prior to 1977)
—	—	1	2022819	DRAPE—galley window (w/RPO 641 & 697) (pattern: edinberg natural) (fabric: lined - color fern beige)
—	—	1	2027948	DRAPE—galley window (w/RPO 685) (eff w/1977) (woven wood)
—	—	1	2022814	DRAPE—rear side window (w/RPO 641 & 697) (pattern: edinberg natural) (fabric: lined - color fern beige)
—	—	2	2003475	DRAPE—rear side window (w/RPO 698) (prior to 1977)
—	2	2	715176	DRAPE—rear side window (w/RPO 690)
—	—	1	2029069	DRAPE—rear side window RH (woven wood) (w/RPO 685) (eff. w/1977)
—	—	1	2027949	DRAPE—rear side window LH (woven wood) (w/RPO 685) (eff. w/1977)
—	—	1	2027441	DRAPE—rear side window (w/RPO 685) (Pattern: bonaire) (Fabric: lined - color ivory)
—	2	2	715183	DRAPE—rear side window (w/RPO 692)
—	2	2	715190	DRAPE—rear side window (w/RPO 693)
—	2	2	NS	DRAPE—rear side window (w/RPO 695, 696)
—	—	2	795081	DRAPE—rear side window (w/RPO 681, 697) (prior to 1977)
—	—	2	2009372	DRAPE—rear side window (w/RPO 683)
—	—	2	2018243	DRAPE—rear side window (2 pair) (w/RPO 698) (1977)
—	—	1	2029074	DRAPE—rear side window RH (woven wood) (w/RPO 698) (1978)
—	—	1	2029073	DRAPE—rear side window LH (woven wood) (w/RPO 698) (1978)
—	—	2	2018255	DRAPE—rear side window (2 pair) (w/RPO 697) (prior to interm 1977) (pattern: glass cloth) (fabric: lined-color gold)
—	—	2	2022814	DRAPE—rear side window (2 pair) (w/RPO 641 & 697) (eff. w/interm 1977) (pattern: Edinberg natural) (fabric: lined-color fern beige)
—	—	1	2022811	DRAPE—rear end (w/RPO 641 & 697) (pattern: edinberg natural) (fabric: lined-color fern beige)
—	—	1	2018254	DRAPE—rear end window (w/RPO 697) (prior to interm 1977) (Pattern: grass cloth) (fabric: lined - color gold)
—	—	1	2018241	DRAPE—rear end window (w/RPO 698) (1977)
—	—	1	2029209	DRAPE—rear end window (w/RPO 698) (1978)
—	—	1	2009375	DRAPE—rear end window (w/RPO 683)
—	—	1	795082	DRAPE—rear end window (w/RPO 681, 697) (prior to 1977)
—	—	1	2003476	DRAPE—rear end window (w/RPO 698) (prior to 1977)
—	1	1	715171	DRAPE—rear end window (w/RPO 690)
—	1	1	715178	DRAPE—rear end window (w/RPO 692)
—	1	1	715185	DRAPE—rear end window (w/RPO 693)
—	1	1	NS	DRAPE—rear end window (w/RPO 695, 696)
—	2	2	715571	TIE BACK—front privacy/divider drape (w/RPO 690)
—	2	2	715573	TIE BACK—front privacy/divider drape (w/RPO 693)
—	2	2	715572	TIE BACK—front privacy/divider drape (w/RPO 692)
—	2	2	715574	TIE BACK—front privacy/divider drape (w/RPO 695, 696)
—	2	2	2021887	TIE BACK—front privacy/divider drape (w/RPO 681, 697) (prior to interm 1977)
—	—	2	2027442	TIE BACK—front privacy/divider drape (w/RPO 685)
—	2	2	2021889	TIE BACK—front privacy/divider drape (w/RPO 698) (prior to 1978)
—	—	2	2029210	TIE BACK—front privacy/divider drape (1978)
—	2	2	2021890	TIE BACK—front privacy/divider drape (w/RPO 683)

FURNISHINGS

KEY 230 260 PART NUMBER

28.110 DRAPES, SLIDES, STOPS, TRACKS (Cont.)

—	—	2	2024790	TIE BACK—front privacy/divider drape (w/RPO 641 & 697) (eff. w/interm 1977)
—	—	5	2029322	CLEAT KIT—drape tie (w/RPO 685, 698) (eff. w/1977)
—	AR	AR	715498	SLIDES—drape (chrome metal w/nylon rollers)
—	—	AR	792886	GLIDE—drapes, windshield, privacy/divider (eff. w/1975)
—	4	4	715472	STOPS—drape track (screw, procure locally)
—	21	21	715473	STOPS—drape track (bracket w/screw eye)
—	AR	AR	707983	TRACK—windshield drape, RH
—	AR	AR	707984	TRACK—windshield drape, LH
—	AR	AR	8884081	TRACK—upper, side windows and end cap drape (75", CTL)
—	AR	AR	8884080	TRACK—lower, side windows and end cap drape (75", CTL)
—	1	1	8884085	TRACK—front privacy/divider drape
—	—	10	2027946	TRACK—window drapery (w/RPO 685, 698) (eff. w/1977) (woven wood)
—	—	1	791839	ROD SET ASSY.—drape (complete) (hardware not incl.) (ref. only) (eff. w/1975 & w/out ZEO6582)
—	—	1	2027936	ROD SET ASSY.—drape (w/RPO 685, 698) (eff w/1977) (ref. only) (woven wood)
—	—	1	2006774	ROD SET ASSY.—drape (complete) (hardware not incl.) (ref. only) (w/ZEO6582)
—	—	4	791183	ROD ASSY.—rear quarter, side windows (eff. w/1975) (SOA)
—	—	1	791181	ROD ASSY.—rear cap, rear window, upper (eff. w/1975) (SOA) (exc./ZEO6582)
—	—	1	2009363	ROD ASSY.—rear cap, rear window, upper (w/ZEO6582) (SOA)
—	—	1	791182	ROD ASSY.—rear cap, rear window, bottom (eff. w/1975) (SOA) (exc./ZEO6582)
—	—	2	791184	ROD—curtain, galley window (eff. w/1975)
—	—	2	791185	ROD ASSY.—curtain, entrance door (eff. w/1975) (SOA)
—	—	4	791186	ROD ASSY.—curtain, front side windows (RH & LH) (eff. w/1975) (SOA)
—	—	1	791661	TRACK—privacy curtain, front (eff. w/1975)
—	—	10	2027946	TRACK—woven wood drapery track
—	—	2	791660	STOP ASSY.—rod end, privacy curtain (eff. w/1975)
—	—	6	791803	FASTENER—hook, curtain rod (eff. w/1975)
—	—	2	792165	RETAINER—drape rod (eff. w/1975)
—	—	4	791179	FASTENER—male shell snap rod (eff. w/1975 & PRIOR TO Serial No. 6V100878)
—	—	4	—	FASTENER—rod, (procure locally) (ref. 9436188) (eff. w/Serial No. 6V100878) (& prior to 1977)
—	—	4	105507	FASTNER—curt male shell snap (eff. w/1977)
—	—	4	688290	RIVET—shell snap fastner (eff. w/1977)
—	—	6	799378	SLEEVE—special, privacy curtain rod (eff. w/1975) (repl. 791804)
—	—	2	2007258	BAR—drape rod splice (eff. w/1975)
—	—	4	2007300	COUPLING—drape rod (eff. w/1975)
—	—	AR	791180	BRACKET—drape rod (wall mtg.) (eff. w/1975)
—	—	2	2030532	SPACER—drape rod bracket (1978)
—	—	10	2039692	SPACER—woven wood drapery track
—	—	AR	791176	END CAP—drape rod (eff. w/1975)
—	1	1	791829	MOLDING—drape track front privacy/divider (ref. 715543)
—	2	2	716852	SCREW—w/s drape RH & LH track to roof trim

NOTE: The following parts are necessary to properly fasten entrance door drapes:

—	—	10	105195	SOCKET—(eff. w/1975)
—	—	10	105189	CAP—(eff. w/1975)
—	—	10	797210	STUD—sheet metal screw (eff. w/1975)

28.120 CABINETS—OVERHEAD

NOTE: “+” indicates not serviced, for reference only. See Group 28.180 for raw material coverings.

—	AR	AR	+	NS	CABINET ASSY.—overhead (w/RPO 690, 692, 693, 695)
—	—	2		791824	CABINET ASSY.—overhead (RH/LH) (w/RPO 681, 697) (68" lg.) (rosewood) (w/ZEO6581) (vehicles built prior to June 21, 1976) (ref. only)

FURNISHINGS

KEY	230	260	PART NUMBER	
28.120 CABINETS—OVERHEAD (Cont.)				
—	—	2	2016730	CABINET ASSY.—overhead (RH/LH) front (w/RPO 641, 697, 698) (68" lg.) (walnut) (w/ZEO6581) (vehicles built after June 21, 1976)
—	—	1	2000338	CABINET ASSY.—overhead, (RH/LH) front (w/RPO 685, 698) (68" lg.) (walnut) (w/ZEO6581)
—	—	1	2014868	CABINET ASSY.—RH front overhead (w/RPO 697 & ZEO 6584)
—	—	1	2018304	CABINET ASSY.—RH front overhead (w/RPO 641, 698 & ZEO6584)
—	—	1	791825	CABINET ASSY.—overhead RH rear (w/RPO 681, 697) (34" lg.) (w/ZEO6581) (vehicles built prior to June 21, 1976) (ref. only)
—	—	1	791830	CABINET ASSY.—overhead LH rear (w/RPO 681, 697) (34" lg.) (w/ZEO6581) (vehicles built prior to June 21, 1976)
—	—	1	2016729	CABINET ASSY.—overhead RH rear (w/RPO 681, 697) (34" lg.) (walnut) (w/ZEO6581) (vehicles built after June 21, 1976)
—	—	1	2016728	CABINET ASSY.—overhead LH rear (w/RPO 681, 697) (34" lg.) (walnut) (w/ZEO6581) (vehicles built after June 21, 1976)
—	—	1	2000336	CABINET ASSY.—overhead, RH rear (w/RPO 641, 685, 698) (w/ZEO6581) (prior to 1978)
—	—	1	2000335	CABINET ASSY.—overhead, LH rear (w/RPO 641, 685, 698) (w/ZEO6581) (prior to 1978)
—	—	1	2016729	CABINET ASSY.—overhead RH rear (w/RPO 641, 698) (w/ZEO6581) (1978)
—	—	1	2016728	CABINET ASSY.—overhead LH rear (w/RPO 641, 698) (w/ZEO6581) (1978)
—	—	1	2008143	CABINET ASSY.—overhead, RH rear (w/RPO 683) (w/ZEO6582) (ref. only)
—	—	1	2008047	CABINET ASSY.—overhead, LH rear (w/RPO 683) (w/ZEO6582) (ref. only)
—	—	1	2018303	CABINET ASSY.—overhead, RH rear (w/RPO 641, 698 & ZEO 6584)
—	—	1	2018302	CABINET ASSY.—overhead LH rear (w/RPO 641, 698 & ZEO6584)
—	—	1	2013782	CABINET ASSY.—overhead RH rear (w/RPO 697 & ZEO6584)
—	—	1	2013781	CABINET ASSY.—overhead LH rear (w/RPO 697 & ZEO6584)
—	—	1	2033437	CABINET ASSY.—overhead (fishing equipment) (w/RPO ENN) (1978) (cabinet is mounted above rear window)
—	—	1	2033435	CABINET ASSY.—overhead (gun rack) (w/RPO ENA) (1978) (RH front cabinet)
—	—	3	2030081	CYLINDER ASSY.—cabinet (fishing equipment & gun rack) (see group 23.044 for lock set & key) (Note: use qty. of (2) w/lock set 2030075 & 2030078) (use qty. (1) w/lock set 2030076, 2030077)
—	—	1	2018200	CABINET ASSY.—overhead galley (w/RPO 641, 698 & ZEO6584)
—	—	1	2013783	CABINET ASSY.—overhead galley (w/RPO 697 & ZEO6584)
—	—	1	2008183	CABINET ASSY.—overhead, galley (w/RPO 683) (ref. only) (w/ZEO6582)
—	—	1	791823	CABINET ASSY.—overhead, galley (w/RPO 681, 697) (59" lg.) (w/ZEO6581) (vehicles built prior to June 21, 1976) (ref. only)
—	—	1	2016727	CABINET ASSY.—overhead, galley (w/RPO 681, 697) (59" lg.) (w/ZEO6581) (vehicles built after June 21, 1976)
—	—	1	2000337	CABINET ASSY.—overhead, galley (w/RPO 641, 685, 698) (w/ZEO6581) (prior to 1978) (ref. only)
—	—	1	2016727	CABINET ASSY.—overhead galley (w/RPO 641, 698) (59" lg.) (w/ZEO6581) (1978)
—	—	3	790353	PAD ASSY.—RH overhead cabinet, (and galley)
—	—	2	790354	PAD ASSY.—LH overhead cabinet
—	1	1	795607	DOOR—small, overhead cabinet (carved) (w/RPO 692, 693, 695, 696) (25.03" x 14.25")
—	5	5	795608	DOOR—large, overhead cabinet (carved) (w/RPO 692, 693, 695, 696) (33.56" x 14.25")
—	AR	AR	NS	DOOR—plain, overhead cabinet (w/RPO 690, 692, 693, 695)
—	—	1	790806	DOOR—small, overhead LH (w/RPO 681, 697) (w/ZEO6581)
—	—	5	790807	DOOR—large, overhead RH (w/RPO 681, 697) (w/out ZEO6584)
—	—	1	2033434	DOOR—overhead gun cabinet (w/RPO ENA)
—	—	1	2033433	DOOR—overhead gun cabinet (w/RPO ENA)
—	—	1	2033436	DOOR—overhead fishing equipment cabinet (w/RPO ENN)
—	—	1	2010672	DOOR ASSY.—overhead, galley RH (w/RPO 681, 697) (walnut) (w/ZEO6581)
—	—	2	2010672	DOOR ASSY.—overhead, galley RH (w/RPO 641, 698) (w/ZEO6581) (1978)
—	—	1	2010637	DOOR ASSY.—overhead, galley LH (w/RPO 681, 697) (walnut) (w/ZEO6581)
—	—	1	2011753	DOOR—overhead rear LH (plain) (w/RPO 683) (w/ZEO6582)
—	—	1	2011755	DOOR—overhead rear RH (plain) (w/RPO 683) (w/ZEO6582)

FURNISHINGS

KEY 230 260 PART NUMBER

28.120 CABINETS—OVERHEAD (Cont.)

—	—	1	2015171	DOOR—overhead rear (w/RPO 697 & ZEO6584)
—	—	1	2015174	DOOR—overhead rear (W/RPO 697 & ZEO6584)
—	—	1	2016653	DOOR—overhead front, rear, galley (RH) (w/RPO 641, 685, 698, ZEO6581 & ZEO6584) (repl. 798786)
—	—	1	2016654	DOOR—overhead front, rear, galley (LH) (w/RPO 641, 685, 698, ZEO6581 & ZEO6584) (repl. 798787)
—	—	AR	715760	HINGE ASSY.—overhead cabinet (eff. w/1975 & prior to 1977)
—	—	AR	2025358	HINGE—overhead cabinet (eff. w/1977)
—	AR	AR	716805	MOULDING—overhead cabinet to bulkhead (25' rolls, CTL)
—	6	6	711466	LATCH—overhead cabinet door
—	AR	AR	—	SCREW—overhead cabinet mounting (ref. 717732) (procure locally)
—	—	22	2248137	U—NUT—overhead cabinet mounting (repl. 791472) (eff. w/1975)
—	—	4	791699	CATCH ASSY.—overhead cabinet (prior to 1977)
—	—	4	2026184	CATCH ASSY.—overhead cabinet (eff. w/1977)
—	—	6	—	BUMPER—overhead cabinet (ref. 791657) (proc. loc.)
—	—	9	2009884	RETAINER—bolt, galley overhead cabinet mtg. (w/ZEO6582, ZEO6584)
—	AR	AR	2013358	BOARD—particle service (.50 x 48.0 x 96.0) (rosewood grain)
—	AR	AR	2013359	BOARD—particle, service (.50 x 48.0 x 96.0) (walnut grain)
—	—	1	2014326	STRUT—front overhead cabinet door lid (incl. steel spring & tube)

28.124 MODULE—CLOSET

NOTE: " + " indicates not serviced, for reference only. See Group 28.180 for raw material coverings.

—	—	1	791821	MODULE ASSY.—closet (w/RPO 681, 697) (exc./ZEO6584) (rosewood) (includes all doors and drawers plus respective items marked with asterisk) (vehicles built prior to June 21, 1976) (ref. only)
—	—	1	2000333	MODULE ASSY.—closet (w/RPO 641, 681, 685, 697, 698) (exc./ZEO6584) (walnut) (includes all doors and drawers plus respective items marked with asterisk) (prior to 1978) (ref. only)
—	—	1	2032762	MODULE ASSY.—closet (w/RPO 641, 697, 698) (w/ZEO6581) (walnut) (1978) (details not available at time of publication)
—	—	1	2008038	MODULE ASSY.—closet (w/RPO 683) (exc./ZEO6584) (rosewood) (includes all doors and drawers plus respective items with asterisk)(ref. only)
—	—	1	2014620	MODULE ASSY.—closet (w/RPO 641, 697, 698 & ZEO6584) (includes all door and drawers plus respective items with asterisk) (ref. only)
—	—	1	* 2008969	DOOR ASSY.—closet main (w/RPO 641, 683, 697, 698) (w/ZEO6582, ZEO6584)
—	—	1	* 790349	DOOR ASSY.—closet main (w/RPO 681, 697) (exc./ZEO6584) (rosewood)
—	—	1	* 2000375	DOOR ASSY.—closet main (w/RPO 641, 685, 698) (exc./ZEO6584) (walnut)
—	1	1	+ 716844	DOOR ASSY.—closet (w/RPO 690) (repl. 715489)
—	1	1	+ 716845	DOOR ASSY.—closet (w/RPO 692, 693, 695, 696) (repl. 715490)
—	—	1	* 2023070	DOOR—linen (large upper) (21.44" x 23.12") (w/RPO 641, 681, 685, 698) (exc./ZEO6584)
—	1	1	NS	LATCH—closet door (First Type) (incl. striker) (ref. 711465)
—	1	1	* 2003710	LATCH—closet door (Second Type) (repl. 711465, 716120)
—	1	1	716121	STRIKER—closet door latch (used w/Second Type latch)
—	—	1	* 790593	STRIKER—latch, closet (eff. w/1975)
—	3	3	* 715492	HINGE—closet door
—	3	3	+ 715493	DOOR—cabinet, clothes closet (w/RPO 690)
—	3	3	+ 715494	DOOR—cabinet, clothes closet (w/RPO 692, 693, 695, 696)
—	—	3	* 2018496	DOOR—cabinet, clothes closet (w/RPO 681, 697)
—	—	2	* 2023069	DOOR—storage (small lower) (21.44" x 13.94") (w/RPO 641, 681, 685, 698) (exc./ZEO6584)
—	—	1	* 2023071	FRONT—wardrobe drawer (21.44" x 7.80") (w/RPO 641, 681, 698) (exc./ZEO6584)
—	—	3	* 791699	CATCH ASSY.—closet door (eff. w/1975) (prior to 1977)
—	—	3	* 2026184	CATCH ASSY.—closet door (eff. w/1977) (w/2000333 module)
—	—	3	790063	HINGE—wardrobe closet (eff. w/1975)
—	—	3	* 797218	HINGE ASSY.—wardrobe door (RH) (bronze) (eff. w/1975) (prior to interm 1977)

FURNISHINGS

KEY 230 260 PART NUMBER

28.124 MODULE—CLOSET (Cont.)

—	—	3	*	797219	HINGE ASSY.—wardrobe door (LH) (bronze) (eff. w/1975) (prior to interm 1977)
—	—	1		2024881	HINGE ASSY.—wardrobe door (RH/LH) (eff. w/interm 1977)
—	—	6		715761	HINGE—cabinet door clothes closet
—	—	3	+	715487	DRAWER—cabinet clothes closet (w/RPO 690)
—	—	3	+	715488	DRAWER—cabinet clothes closet (w/RPO 692, 693, 695, 696)
—	—	3	*	2018495	DRAWER—cabinet clothes closet (w/RPO 681, 697)
—	—	10	*	791193	GUIDE—drawer (plastic) (eff. w/1975)
—	—	5	*	791192	SLIDE ASSY.—drawer (steel) (eff. w/1975)
—	—	AR	*	—	BUMPER—door and drawer (plastic) (eff. w/1975) (procure locally)
—	AR	AR		716805	MOULDING—closet bulkhead to wall (25' roll. CTL)
—	—	3		711466	LATCH—cabinet door
—	—	1	*	NS	HOOK—robe (brass) (eff. w/1975) (not serviced)
—	—	1	*	790062	RACK—wardrobe closet (8" long) (eff. w/1975)
—	—	1	*	790060	RACK—wardrobe closet (14-3/4" long) (eff. w/1975)
—	—	1	*	2007917	RACK—wardrobe closet (25.50" long) (eff. w/1976)
—	—	2	*	791819	BRACKET—closet mounting
—	—	1	*	791820	BRACKET—closet mounting
—	—	1	*	799288	BRACKET—closet mounting
—	—	1		793336	COVER—thermostat wiring harness conduit
—	—	1	*	NS	SPACER—striker (eff. w/1975) (procure locally)
—	—	2		2000001	BRACKET—closet module to roof member (ref. 2000001) (make locally)
—	AR	AR		2013358	BOARD—particle. service (.50 x 48.0" x 96.0) (rosewood grain)
—	AR	AR		2013359	BOARD—particle. service (.50 x 48.0 x 96.0") (walnut grain)
—	—	1		—	MIRROR ASSY.—closet module (procure locally) (w/ZEO6584)
—	—	1		—	STOP—closet module door (procure locally) (w/ZEO6584)
—	—	1		2025333	BOLT ASSY.—closet SOA

28.128 MODULE—GALLEY

NOTE: " + " indicates not serviced, for reference only. See Group 28.180 for raw material coverings.

—	—	1		2016725	MODULE ASSY.—galley (walnut) (w/RPO 681, 697) (exc./ ZEO6584) (vehicles built after June 21, 1976) (prior to 1978)
—	—	1		2009960	MODULE ASSY.—galley (w/RPO 641) (exc./ ZEO6584) (includes respective items marked with asterisk) (ref. only)
—	—	1		2029507	MODULE ASSY.—galley (w/RPO 641 & UND) (w/ZEO6581) (1978)
—	—	1		2026580	MODULE ASSY.—galley (w/RPO 641, exc./ RPO UND) (w/ZEO6581) (1978)
—	—	1		2029506	MODULE ASSY.—galley (w/RPO 697, 698 & UND) (w/ZEO6581) (1978)
—	—	1		2026579	MODULE ASSY.—galley (w/RPO 697, 698) (w/out RPO UND) (w/ZEO6581) (1978)
—	—	1		791827	MODULE ASSY.—galley (rosewood) (w/RPO 681, 697) (w/out ZEO6584) (includes respective items marked with asterisk) (vehicles built prior to June 21, 1976) (ref. only)
—	—	1		2000334	MODULE ASSY.—galley (w/RPO 698) (w/out ZEO6584) (includes respective items marked with asterisk) (ref. only)
—	—	1		2008018	MODULE ASSY.—galley (w/RPO 683) (w/ZEO6584) (ref. only)
—	—	1		2027917	MODULE ASSY.—galley (w/RPO 685) (eff w/1977)
—	—	1		2014619	MODULE ASSY.—galley (w/RPO 698 & ZEO6584) (ref. only)
—	—	1		2014311	MODULE ASSY.—galley (w/RPO 641 & ZEO6584) (ref. only)
—	—	1		2016753	MODULE ASSY.—galley (w/RPO 697 & ZEO6584)
—	AR	AR	+	NS	Door galley, upper & LOWER (plain) (w/RPO 690, 692, 693, 695, 696)
—	—	1	*	790810	DOOR—galley, large, lower, LH (under oven) (w/RPO 681, 697) (21.5/16" x 14.1/2") (rosewood) (w/out ZEO6584)
—	—	1		715783	DOOR—lower, large (w/RPO 692, 693, 695, 696) (21 5/16 x 14 1/2) (carved) (exc./hinges)
—	—	1		2010624	DOOR—lower, LH (w/RPO 681, 697) (21 5/16 x 14 1/2) (walnut) (exc./ZEO6584)
—	—	1		2016664	DOOR ASSY.—under stove (SOA) (22 3/8 x 11½) (w/RPO 641, 698 & w/ZEO6584)
—	—	1		2015170	DOOR ASSY.—under stove (SOA) (22 3/8 x 11½) (w/RPO 697 & w/ZEO6584)
—	—	1		2016655	DOOR ASSY.—under sink (large) (SOA) (18 ¾ x 11½) (w/RPO641, 698 & w/ZEO6584)

FURNISHINGS

KEY 230 260 PART NUMBER

28.128 MODULE—GALLEY (Cont.)

--	--	1	2015167	DOOR ASSY.—under sink (large) (SOA) (18¾ x 14½) (w/RPO 697 & ZE06584)
--	--	1	2026249	DOOR ASSY.—galley under oven (w/RPO 685) (eff w/1977);SOA) (25 7/8 x 12½)
--	1	1	795611	DOOR—galley, RH, lower (carved) (w/RPO 692, 693, 695, 696) (21.31" x 14.50") (w/hinges)
--	--	1	2026248	DOOR—galley, RH lower (17¾ x 14½) (w/RPO 685) (eff. w/1977)
--	1	1	795612	DOOR—galley, LH, lower (carved) (w/RPO 692, 693, 695, 696) (21.31" x 14.50") (w/hinges)
--	--	1	* 798788	DOOR—galley, large (under oven) (w/RPO 641, 698) (21 5/16 x 14 1/2) (louvered) (walnut) (exc./ZE06584)
--	--	1	2029558	DOOR—galley, large (under microwave oven) (25 7/8 x 13") (w/RPO 641, 694, 698, UND & w/ZE06581) (1978)
--	--	1	* 790811	DOOR—galley, small, lower, center (w/RPO 681, 697) (17.3/4" x 14.1/2") (rosewood) (exc./ZE06584)
--	--	3	* 798789	DOOR—galley, small (w/RPO 641, 698) (17 3/4 x 14 1/2 louvered) (walnut) (exc./ZE06584)
--	2	2	795609	DOOR—galley, RH, upper and lower (carved) (w/RPO 692, 693, 695, 696) (17.18" x 14.50") (w/hinges)
--	--	1	2026246	DOOR—galley, LH lower under drawers (12½ x 14½) (w/RPO 685) (eff. w/1977)
--	1	1	795610	DOOR—galley, LH, upper and lower (carved) (w/RPO 692, 693, 695, 696) (17.50" x 14.43") (w/hinges)
--	--	2	* 790812	DOOR—galley, upper and lower (w/RPO 681, 697) (17.72" x 14.48") (rosewood) (exc./ZE06584)
--	--	1	2027849	DOOR—galley, upper RH (17¾ x 14") (w/RPO 685) (eff. w/1977)
--	--	2	NPN	DOOR—galley, lower, small (w/RPO 692, 693, 695, 696) (17.82" x 14.43") (carved) (exc./hinges) (ref. 715767) (procure locally)
--	--	1	2010627	DOOR—galley, upper & lower RH (w/RPO 681, 697) (17.75" x 14.50") (walnut) (exc./ZE06584)
--	--	1	* 2016923	DOOR—galley, lower center (17¾ x 14½) (w/RPO 641, 697, 698) (w/out RPO UND) (w/ZE06581)
--	--	1	* 2026246	DOOR—galley, lower center (12½ x 14½) (w/RPO 641, 697, 698, UND & w/ZE06581) (w/microwave oven)
--	--	1	2027849	DOOR—galley, upper RH (17¾ x 14") (w/RPO 641, 697, 698, UND & w/ZE06581) (w/microwave oven)
--	--	1	2026248	DOOR—galley, lower RH (17¼ x 14½) (w/RPO 641, 697, 698, UND & w/ZE06581) (w/microwave oven)
--	--	1	2016924	DOOR—galley, lower center (w/RPO 681, 697) (17 3/4 x 14 1/2) (walnut) (w/out ZE06584)
--	--	1	2016663	DOOR ASSY.—under drawer (SOA) (16½ x 11½) (w/RPO 641, 698, & w/ZE06584)
--	--	1	2015166	DOOR ASSY.—under drawer (SOA) (16½ x 11½) (w/RPO 697 & ZE06584)
--	--	1	2016656	DOOR ASSY.—under sink (small) (SOA) (18¾ x 11½) (w/RPO 641, 698 & w/ZE06584)
--	--	1	2015169	DOOR ASSY.—under sink (small) (SOA) (18¼ x 11½) (w/RPO 697 & ZE06584)
--	--	1	2028356	DOOR—galley, under sink (w/grill for furnace) (17¼ x 14½) (w/all ZE06581 models)
--	--	2	2016652	FRONT—drawer, galley (16½ x 6¾) (w/RPO 641, 698 & w/ZE06584)
--	--	2	2015165	FRONT—drawer, galley (16½ x 6¾) (w/RPO 697, & ZE06584)
--	--	1	2010675	FRONT—drawer, galley (17¾ x 6¾) (w/RPO 681, 697) (exc./ZE06584) (walnut)
--	2	2	NPN	FRONT—drawer, galley (procure locally) (w/RPO 692, 693, 695, 696) (17.81" x 6.73") (carved) (ref. 795613) (procure locally)
--	--	2	* 790809	FRONT—drawer, galley (17.81" x 6.73") (w/RPO 681, 697) (exc. ZE06584)
--	--	2	* 798791	FRONT—drawer, galley (17¼ x 6¼) (exc. ZE06584) (prior to 1976)
--	--	2	2026245	FRONT—drawer, galley (12.62 x 6¼) (w/RPO 641, 697, 698, UND & w/ZE06581) (1978) (1978)
--	--	1	790377	STOP—door, bath (at galley)
--	--	1	* 799287	BRACKET—angle
--	--	1	* 799288	BRACKET—corner
--	--	1	* 797217	SCREW—hinge
--	AR	AR	2014897	DRAWER ASSY.—galley, top (18.80" x 14.50") (w/ZE06584 std.)
--	AR	AR	2014899	DRAWER ASSY.—galley, Bottom (18.80" x 14.50") (w/ZE06584 std.)
--	AR	AR	NS	DRAWER—galley, small & large (w/RPO 690, 692, 693, 695, 696)
--	AR	AR	2006744	DRAWER—galley & dresser (14.12" x 3.50" x 18.50) (w/ZE06582)
--	AR	AR	2006746	DRAWER—galley & dresser (17.12" x 5.25" x 18.50") (w/ZE06582)
--	--	2	2026245	DRAWER—galley (w/RPO 685) (eff w/1977)
--	AR	AR	2006747	KIT—drawer mtg. (w/ZE06582)
--	--	2	715761	HINGE—galley cabinet door (prior to 1975)
--	--	8	* 792815	HINGE SET—galley cabinet door (eff. w/1975) (prior to 1977)
--	--	4	2024881	HINGE SET—galley cabinet door (eff. w/1977)

FURNISHINGS

KEY 230 260 PART NUMBER

28.128 MODULE—GALLEY (Cont.)

—	—	4	*	791699	CATCH ASSY.—galley door (single roller) (eff. w/1975)
—	—	1	—	—	CATCH ASSY.—galley door (double roller) (eff. w/1975) (ref. 2007759) (procure locally)
—	AR	AR		716810	MOULDING—bead, galley to closet module (25' roll, CTL)
—	AR	AR		716805	SEAL—galley bulkhead to wall (25' rolls, CTL)
—	—	1	*	791816	ANGLE—galley support (eff. w/1975)
—	—	2		791819	BRACKET—galley mounting (eff. w/1975) (prior to 1978)
—	—	1	*	2028112	BRACKET—galley mounting (1978)
—	—	2		2393434	SPACER—galley mounting (eff. w/1975) (repl. 661978) (exc./ZEO6582, ZEO6584)
—	—	2		669171	SPACER—galley mounting (w/ZEO6582, ZEO6584)
—	—	1	*	790831	TOP ASSY.—galley counter (w/RPO 641, 681, 697, 698) (color: harvest leather) (exc./ZEO6584) (prior to 1978)
—	—	1	*	2026573	TOP ASSY.—galley counter (w/RPO 641) (w/ZEO6581) (1978) (w/out microwave oven)
—	—	1	*	2026572	TOP ASSY.—galley counter (w/RPO 697, 698) (w/ZEO6581) (1978) (w/out microwave oven)
—	—	1		2026840	TOP—galley counter (w/RPO 641) (w/ZEO6581) (1978) (w/microwave oven)
—	—	1		2026839	TOP—galley counter (w/RPO 697, 698) (w/ZEO6581) (1978) (w/microwave oven)
—	—	1		2014893	TOP—galley counter (w/RPO 641 & w/ZEO6584)
—	—	1		2014894	TOP—galley counter (w/RPO 697, 698 & w/ZEO6584)
—	—	1		2027916	TOP—galley counter (w/RPO 685) (eff w/1977)
—	—	1		2008685	TOP—galley counter (tan linen) (w/ZEO6582)
—	1	1		717739	TOP—galley (blue) (no cut outs) (w/RPO 693)
—	1	1		792831	TOP—galley (green) (no cut outs) (w/RPO 690)
—	1	1		792832	TOP—galley (gold) (no cut outs) (w/RPO 692, 695, 696)
—	—	1		2027812	COMPARTMENT ASSY.—beverage dispenser, (w/RPO 641, 697, 698) (w/ZEO6581) (mounted on galley counter top) (1978)
—	—	1		792052	COVER—sink (or chopping block) (small) (eff. w/1975)
—	—	1		792174	COVER—sink (or chopping block) (large) (eff. w/1975)
—	—	1		2234819	COVER PKG.—sink (or chopping block) (small & large block)
—	—	2		2279500	U—NUT—galley module to body (repl. 1494258)
—	—	2	*	791192	SLIDE SET—drawer (steel) (eff. w/1975)
—	—	4	*	791193	GUIDE—drawer (eff. w/1975)
—	—	AR	*	—	BUMPER—drawer & DOOR (eff. w/1975) (ref. 791657) (procure locally)
—	AR	AR		2013358	BOARD—particle, service (.50 x 48.0 x 96.0") (rosewood grain)
—	AR	AR		2013359	BOARD—particle, service (.50 x 48.0 x 96.0") (walnut grain)
—	1	1		791819	BRACKET—galley module to closet module (eff. w/1976 & ZEO6581)

FURNISHINGS

KEY 230 260 PART NUMBER

28.130 PLUMBING—GALLEY MODULE

1	1	1	790333	INLET ASSY. (VALVE)—city water (located at utilities compartment) (prior to 1978)
2	—	AR	657558	STRAP—(repl. 2435539)
3	—	1	790337	PIPE ASSY.—water (eff. w/1975) (exc./ZEO6582, ZEO6584)
3	—	1	2006650	PIPE ASSY.—water (w/ZEO6582) (ref. only)
3	—	1	2012418	PIPE ASSY.—water (w/ZEO6584)
4	—	3	9414716	SCREW—clamp (exc./ZEO6582)
6	—	3	791156	CLAMP—sanitary plumbing (eff. w/1975)
7	—	1	790388	PLUMBING—sanitary (eff. w/1975) (prior to 1978) (exc./ZEO6582, ZEO6584)
7	—	1	2027435	PIPE ASSY.—sanitary (eff. w/1978) (exc./ZEO6582, ZEO6584)
7	—	1	2027435	PIPE ASSY.—sanitary plumbing (w/RPO 685) (eff w/1977)
7	—	1	2026277	PIPE ASSY.—sanitary plumbing (w/ZEO6582, ZEO6584)
8	—	AR	8884956	TUBE—fresh water (25') (CTL) (eff. w/1975)
9	—	1	711949	TEE—fresh water, drain at bulkhead (eff. w/1975)
10	—	1	2061210	FITTING
11	—	1	219758	NUT—fitting
12	1	1	—	FAUCET—galley (see groups 28.063 and 28.064)
13	1	1	—	SINK—galley (see group 28.063)
14	—	2	791948	FLANGE—gasket, (5" dia.) steel (eff. w/1975)
14	—	1	791950	GASKET—flange
—	—	1	2032349	INLET ASSY. (VALVE)—city water (1978)
—	—	1	796779	ELBOW—fresh water inlet
—	—	1	2034653	TUBE ASSY.—city water fill (5/8 O.D.) (7.25" lg.)
—	—	1	2034655	TUBE ASSY.—city water fill (5/8 O.D.) (23.00" lg.)
—	—	3	2034672	BUSHING—city water fill tube
—	—	1	2034649	TEE—city water fill tube
—	—	2	796778	VALVE ASSY.—city water fill check
—	—	1	2034646	TEE—city water fill to galley
—	—	1	2034662	TUBE ASSY.—galley cold water
—	—	3	2034673	TEE—galley cold & hot water tube
—	—	5	2034669	COUPLING—galley cold water tube
—	—	2	NPN	COCK—drain galley (ref. 110293) (procure locally)
—	—	2	8877861	SLEEVE—galley drain cock
—	—	1	—	NUT—galley drain cock (ref. 114627) (procure locally)
—	—	1	2020891	STRAINER ASSY.—galley sink
—	—	1	2034665	TUBE—cold water cross over
—	—	1	2034645	TUBE—hot water cross over
—	—	2	2020892	DRAIN—galley sink
—	—	2	—	WASHER—galley sink drain nut (ref. 2020886) (procure locally)
—	—	1	2010765	ADAPTER ASSY.—galley drain to holding tank
—	—	1	NPN	SEAL—galley drain to holding tank (ref. 2020895) (procure locally)
—	—	2	2007999	BLOCK—pipe, sanitary plumbing (w/ZEO6582, ZEO6584)
—	—	2	335551	SCREW—clip, sanitary plumbing (w/ZEO6582, ZEO6584)

28.132 DAVO/BUNK FRONT

NOTE: " + " indicates not serviced, for references only. See Group 28.180 for raw material coverings.

—	AR	AR	+	NS	SEAT ASSY.—RH & LH davo/bunk (w/RPO 690, 692, 693, 695)
—	—	1	—	794544	SEAT ASSY.—LH davo/bunk, (complete bunk) (w/RPO 681)
—	—	1	—	790305	SEAT ASSY.—LH davo/bunk, (complete bunk) (w/RPO 697) (prior to 1977) (w/first design strap)
—	—	1	—	2000649	SEAT ASSY.—LH davo/bunk, (complete bunk) (w/RPO 698) (prior to 1977) (w/first design strap)
—	—	1	—	2010331	SEAT ASSY.—LH davo/bunk (complete bunk) (w/RPO 641) (w/second design strap) (1977) (ref. only)
—	—	1	—	2028520	SEAT ASSY.—LH davo/bunk (complete bunk) (w/RPO 641) (1978) (repl. 2010331)
—	—	1	—	2028584	SEAT ASSY.—LH davo/bunk (complete bunk) (w/RPO 697) (1978) (repl. 2016086)
—	—	1	—	2027548	SEAT ASSY.—LH davo/bunk (complete bunk) (w/RPO 685) (eff. w/1977)

FURNISHINGS

KEY 230 260 PART NUMBER

28.132 DAVO/BUNK FRONT (Cont.)

—	—	1	2016086	SEAT ASSY.—LH davo/bunk (complete bunk) (w/RPO 697) (w/second design strap) (1977) (ref. only)	
—	—	1	2016081	SEAT ASSY.—LH davo/bunk (complete bunk) (w/RPO 698) (w/second design strap) (1977) (ref. only)	
—	—	1	2028521	SEAT ASSY.—LH davo/bunk (complete bunk) (w/RPO 698) (1978) (repl. 2016081)	
—	—	1	2027138	BACK ASSY.—LH davo/bunk (SOA) (w/RPO 641) (prior to 1978)	
—	—	1	2040515	BACK ASSY.—LH davo/bunk (SOA) (w/RPO 641) (1978)	
—	—	1	2003772	BACK—LH davo/bunk (SOA) (w/RPO 681)	
—	—	1	799269	BACK—LH davo/bunk (SOA) (w/RPO 697) (prior to 1978)	
—	—	1	2040521	BACK—LH davo/bunk (SOA) (w/RPO 697) (1978)	
—	—	1	2003777	BACK—LH davo/bunk (SOA) (w/RPO 698) (prior to 1978)	
—	—	1	2040518	BACK—LH davo/bunk (SOA) (w/RPO 698) (1978)	
—	—	1	2030941	BACK ASSY.—LH davo/bunk (SOA) (w/RPO 685)	
—	—	1	2027137	SEAT ASSY.—LH davo/bunk (SOA) (w/RPO 641) (prior to 1978)	
—	—	1	2040514	SEAT ASSY.—LH davo/bunk (SOA) (w/RPO 641) (1978)	
—	—	1	2003773	SEAT ASSY.—LH davo/bunk (SOA) (w/RPO 681)	
—	—	1	2030944	SEAT ASSY.—LH davo/bunk (SOA) (w/RPO 685)	
—	—	1	799270	SEAT ASSY.—LH davo/bunk (SOA) (w/RPO 697) (prior to 1978)	
—	—	1	2040520	SEAT ASSY.—LH davo/bunk (SOA) (w/RPO 697) (1978)	
—	—	1	2003781	SEAT ASSY.—LH davo/bunk (SOA) (w/RPO 698) (prior to 1978)	
—	—	1	2040517	SEAT ASSY.—LH davo/bunk (SOA) (w/RPO 698) (1978)	
—	—	1	796763	SEAT ASSY.—RH davo/bunk. (complete bunk) (w/RPO 681)	
—	—	1	799365	SEAT ASSY.—RH davo/bunk. (complete bunk) (w/RPO 697) (prior to 1977) (w/first design strap)	
—	—	1	2000937	SEAT ASSY.—RH davo/bunk. (complete bunk) (w/RPO 698) (prior to 1977) (w/first design strap)	
—	—	1	2010349	SEAT ASSY.—RH davo/bunk (complete bunk) (w/RPO 641) (w/second design strap) (1977) (ref. only)	
—	—	1	2016078	SEAT ASSY.—RH davo bunk (complete bunk) (w/RPO 697) (second design (ref. only)	
—	—	1	2016087	SEAT ASSY.—RH davo bunk (complete bunk) (w/RPO 698) (second design strap) (1977) (ref. only)	
—	—	1	2028518	SEAT ASSY.—RH davo/bunk (w/RPO 641) (1978) (repl. 2010349)	
—	—	1	2028582	SEAT ASSY.—RH davo/bunk (w/RPO 697) (1978) (repl. 2016078)	
—	—	1	2028519	SEAT ASSY.—RH davo/bunk (w/RPO 698) (1978) (repl. 2016087)	
—	AR	AR	+	NS	BACK ASSY.—RH & LH davo/bunk (w/RPO 690, 692, 693, 695)
—	—	1		2026188	BACK ASSY.—RH davo/bunk (SOA) (w/RPO 641)
—	—	1		2026186	BACK ASSY.—RH davo/bunk (SOA) (w/RPO 681)
—	—	1		2026185	BACK ASSY.—RH davo/bunk (SOA) (w/RPO 697)
—	—	1		2026187	BACK ASSY.—RH davo/bunk (SOA) (w/RPO 698)
—	—	1		2026194	SEAT ASSY.—RH davo/bunk (SOA) (w/RPO 641)
—	—	1		2026192	SEAT ASSY.—RH davo/bunk (SOA) (w/RPO 681)
—	—	1		2026191	SEAT ASSY.—RH davo/bunk (SOA) (w/RPO 697)
—	—	1		2026193	SEAT ASSY.—RH davo/bunk (SOA) (w/RPO 698)
—	—	1		794547	REST—davo arm (w/RPO 681) (first design)
—	—	1		792155	REST—davo arm (w/RPO 697) (first design)
—	—	1		2000650	REST—davo arm (w/RPO 698) (first design)
—	—	1		2026200	REST—davo arm (w/RPO 641) (second design)
—	—	1		2026197	REST—davo arm (w/RPO 681) (second design)
—	—	1		2026195	REST—davo arm (w/RPO 697) (second design)
—	—	1		2026198	REST—davo arm (w/RPO 698) (second design)
—	1	1	+	715717	CUSHION—seat, davo/bunk (w/RPO 690)
—	1	1	+	715718	CUSHION—seat, davo/bunk (w/RPO 692)
—	1	1	+	715719	CUSHION—seat, davo/bunk (w/RPO 693)
—	1	1	+	715720	CUSHION—seat, davo/bunk (w/RPO 695)
—	2	2		717371	HINGE—seat back, extension davo/bunk (piano hinge)
—	2	2		715762	HINGE—seat access compartment, davo/bunk
—	2	2		NS	PIN—hinge (5/16" x 1 1/2 steel dowel) (procure locally) (ref. 141227)
—	4	4		798100	CAP—retainer, pin, bracket to wall
—	2	2		2007778	BRACKET—linkage, mount to wall
—	2	2		791170	HOOK—strap (repl. 717373) (prior to 1977)
—	2	2		791171	COVER—davo/bunk hook (repl. 717374) (prior to 1977)
—	—	2		2016387	HOOK—strap (eff. w/1977)
—	2	2		715829	KIT—davo/bunk seat belt (prior to 1975)
—	—	2		2002841	KIT—seat belt, davo/bunk (w/RPO 698)
—	2	2		717380	STRAP—davo/bunk (black) (prior to 1975)
—	1	1		790694	TAG—non—belted seat restriction

FURNISHINGS

KEY 230 260 PART NUMBER

28.132 DAVO/BUNK FRONT (Cont.)

—	—	2	2027149	BELT ASSY.—davo seat (lap belt) (w/RPO 641) (repl. 2010359)
—	—	2	793971	BELT ASSY.—davo seat (lap belt) (w/RPO 681, 697) (repl. 790381)
—	—	1	2029287	KIT—davo seat (lap belt) (w/RPO 685) (repl. 2027544)
—	—	1	799271	LINKAGE ASSY.—back, RH (SOA) (eff. w/1975) (& prior to 1977)
—	—	1	799272	LINKAGE ASSY.—back, LH (SOA) (eff. w/1975) (& prior to 1977)
—	—	1	2026189	LINKAGE ASSY.—back, RH (SOA) (eff. w/1977)
—	—	1	2026190	LINKAGE ASSY.—back, LH (SOA) (eff. w/1977)
—	—	2	796762	BELT—(strap) (attaches to the ceiling) (w/RPO 681, 697) (eff w/1975 & prior to 1977)
—	—	2	2003776	BELT—(strap) (attaches to the ceiling) (w/RPO 698) (eff w/1975 & prior to 1977)
—	—	1	2030945	BELT—(strap) (attaches to the ceiling) (w/RPO 685)
—	—	2	2022837	BELT ASSY.—(strap) (attaches to the ceiling) (SOA) (w/RPO 641) (eff w/1977)
—	—	2	2022838	BELT ASSY.—(strap) (attaches to the ceiling) (SOA) (w/RPO 697) (eff w/1977)
—	—	2	2022839	BELT ASSY.—(strap) (attaches to the ceiling) (SOA) (w/RPO 698) (eff w/1977)
—	—	1	2027104	PANEL—RH floor to seat (w/RPO 641)
—	—	1	2027111	PANEL—LH floor to seat (w/RPO 641)
—	—	1	2030946	PANEL—LH floor to seat (w/RPO 685)
—	—	1	2003775	PANEL—RH/LH floor to seat (w/RPO 681) (first design)
—	—	1	799273	PANEL—floor to seat (w/RPO 697) (first design)
—	—	1	2003780	PANEL—floor to seat (w/RPO 698) (first design)
—	—	1	2027102	PANEL—PH floor to seat (w/RPO 681) (second design)
—	—	1	2027108	PANEL—LH floor to seat (w/RPO 681, 697) (second design)
—	—	1	2027101	PANEL—RH floor to seat (w/RPO 697) (second design)
—	—	1	2027103	PANEL—RH floor to seat (w/RPO 698) (second design)
—	—	1	2027110	PANEL—LH floor to seat (w/RPO 698) (second design)
—	—	2	799274	SPRING—mechanism, back (eff. w/1975)
—	—	2	799275	GRIP—actuator, plastic (eff. w/1975)
—	—	AR	2027141	BUTTON—strap (1 3/4") (w/RPO 641)
—	—	AR	2003774	BUTTON—strap (1 3/4") (w/RPO 681)
—	—	AR	2029996	BUTTON—strap (1 3/4") (w/RPO 685)
—	—	AR	799276	BUTTON—strap (1 3/4") (w/RPO 697)
—	—	AR	2003779	BUTTON—strap (1 3/4") (w/RPO 698)
—	—	2	791969	BRACKET—davo/bunk (anchor—channel) (aluminum) (1.74 x 2.62)

28.134 BUNKS/TWIN REAR UPPER

—	—	1	2022322	BUNK ASSY.—rear upper LH (w/RPO 641 & ZE06584)
—	—	1	2022318	BUNK ASSY.—rear upper LH (w/RPO 697 & ZE06584)
—	—	1	2022320	BUNK ASSY.—rear upper LH (w/RPO 698 & ZE06584)
—	—	1	2022325	BUNK ASSY.—rear upper RH (w/RPO 641 & ZE06584)
—	—	1	2022319	BUNK ASSY.—rear upper RH (w/RPO 697 & ZE06584)
—	—	1	2022321	BUNK ASSY.—rear upper RH (w/RPO 698 & ZE06584)
—	—	1	2013222	BOLSTER—twin rear upper LH (pillow) (w/RPO 641 & ZE06584)
—	—	1	2013228	BOLSTER—twin rear upper LH (pillow) (w/RPO 697 & ZE06584)
—	—	1	2013240	BOLSTER—twin rear upper LH (pillow) (w/RPO 698 & ZE06584)
—	—	1	2013223	BOLSTER—twin rear upper RH (pillow) (w/RPO 641 & ZE06584)
—	—	1	2013229	BOLSTER—twin rear upper RH (pillow) (w/RPO 697 & ZE06584)
—	—	1	2013241	BOLSTER—twin rear upper RH (pillow) (w/RPO 698 & ZE06584)
—	—	12	2027141	BUTTON—strap (1 3/4") (w/RPO 641)
—	—	12	2029996	BUTTON—strap (1 3/4") (w/RPO 685)
—	—	12	799276	BUTTON—strap (1 3/4") (w/RPO 697)
—	—	12	2003779	BUTTON—strap (1 3/4") (w/RPO 698)
—	—	2	799274	SPRING—back (w/RPO 641, 697, & 698)
—	—	1	2028530	LINKAGE—back RH (w/2022318, 2022320, & 2022322 bunk assy.)
—	—	1	2028531	LINKAGE—back LH (w/2022318, 2022320, & 2022322 bunk assy.)
—	—	1	2028535	LINKAGE—back RH (w/2022319, 2022321, & 2022325 bunk assy.)
—	—	1	2028536	LINKAGE—back LH (w/2022319, 2022321, & 2022325 bunk assy.)
—	—	2	2028533	BELT—w/connector (w/RPO 641)
—	—	2	2028532	BELT—w/connector (w/RPO 697)
—	—	2	2028534	BELT—w/connector (w/RPO 698)
—	—	1	2022276	SUPPORT—rear upper LH bunk
—	—	1	691611	SUPPORT—rear upper RH bunk
—	—	2	791969	ANCHOR—rear upper bunk
—	—	4	2007778	BRACKET—rear upper wall mounting

FURNISHINGS

KEY 230 260 PART NUMBER

28.134 BUNKS/TWIN REAR UPPER (Cont.)

—	—	4	2016387	HOOK—rear upper
—	—	4	2016388	COVER—rear upper hook
—	—	8	798100	CAP—rear upper

28.136 DINETTE/DOUBLE BED

NOTE: " + " indicated not serviced, for reference only. See Group 28.180 for raw material coverings.

—	—	1	2010338	SEAT ASSY.—dinette, front facing (incl. cushion) (complete) (w/RPO 641) (prior to 1978) (ref. only)
—	—	1	2028517	SEAT ASSY.—dinette, front facing (incl. cushion) (complete) (w/RPO 641) (1978) (repl. 2010338)
—	—	1	794543	SEAT ASSY.—dinette, front facing (incl. cushion) (complete) (w/RPO 681)
—	—	1	2006625	SEAT ASSY.—dinette, front facing (incl. cushion) (complete) (w/RPO 683)
—	—	1	790304	SEAT ASSY.—dinette, front facing (incl. cushion) (complete) (w/RPO 697) (prior to 1978) (ref. only)
—	—	1	2028580	SEAT ASSY.—dinette, front facing (incl. cushion) (complete) (w/RPO 697) (1978) (repl. 790304)
—	—	1	2000651	SEAT ASSY.—dinette, front facing (incl. cushion) (complete) (w/RPO 698) (prior to 1978) (ref. only)
—	—	1	2028516	SEAT ASSY.—dinette front facing (incl. cushion) (complete) (w/RPO 698) (1978) (repl. 2000651)
—	—	1	2027545	SEAT ASSY.—dinette front facing (incl. cushion) (complete) (w/RPO 685) (eff w/1977)
—	—	1	2010339	SEAT ASSY.—dinette rear facing (incl. cushion) (complete) (w/RPO 641) (prior to 1978) (ref. only)
—	—	1	2028515	SEAT ASSY.—dinette rear facing (incl. cushion) (complete) (w/RPO 641) (1978) (repl. 2010339)
—	—	1	794542	SEAT ASSY.—dinette rear facing (incl. cushion) (complete) (w/RPO 681)
—	—	1	2006626	SEAT ASSY.—dinette rear facing (incl. cushion) (complete) (w/RPO 683)
—	—	1	790303	SEAT ASSY.—dinette rear facing (incl. cushion) (complete) (w/RPO 697) (prior to 1978) (ref. only)
—	—	1	2028581	SEAT ASSY.—dinette rear facing (incl. cushion) (complete) (w/RPO 697) (1978) (repl. 790303)
—	—	1	2000652	SEAT ASSY.—dinette rear facing (incl. cushion) (complete) (w/RPO 698) (prior to 1978) (ref. only)
—	—	1	2028514	SEAT ASSY.—dinette rear facing (incl. cushion) (complete) (w/RPO 698) (1978) (repl. 2000652)
—	—	1	2027546	SEAT ASSY.—dinette rear facing (incl. cushion) (complete) (w/RPO 685) (eff. w/1977)
—	AR	AR	+	NS SEAT ASSY.—front & rear (w/RPO 690, 692, 693, 695, 696)
—	—	1	2024770	BACK ASSY.—upper front facing seat SOA (w/RPO 641)
—	—	1	2024763	BACK ASSY.—upper rear facing seat SOA (w/RPO 641)
—	—	1	2003760	BACK ASSY.—upper front facing seat (SOA) (w/RPO 681)
—	—	1	2030928	BACK ASSY.—front facing seat (w/RPO 685) (eff w/1977)
—	—	1	2030936	BACK ASSY.—rear facing seat (w/RPO 685) (eff w/1977)
—	—	1	799253	BACK ASSY.—upper front facing seat (SOA) (w/RPO 697)
—	—	1	2024099	BACK ASSY.—upper rear facing seat (SOA) (w/RPO 697)
—	—	1	2003766	BACK—upper front facing seat (SOA) (w/RPO 698)
—	—	1	2024762	BACK—upper rear facing (SOA) (w/RPO 698)
—	—	1	2024100	SEAT ASSY.—lower (SOA) (w/RPO 641)
—	—	1	2030931	SEAT ASSY.—front & rear facing (w/RPO 685) (eff w/1977)
—	—	1	2003761	SEAT—lower (SOA) (w/RPO 681)
—	—	1	799254	SEAT—lower (SOA) (w/RPO 697)
—	—	1	2003767	SEAT—lower (SOA) (w/RPO 698)
—	2	2	—	CHANNEL—front and rear dinette seat back to wall (procure locally) (ref. 715499)
—	AR	AR		716809 T—MOULDING—seat back (25' rolls. CTL) (w/RPO 692, 693, 695, 696)
—	AR	AR		716808 T—MOULDING—seat back (w/RPO 690) (25' roll, CTL)

FURNISHINGS

KEY 230 260 PART NUMBER

28.136 DINETTE/DOUBLE BED (Cont.)

-	1	1		715475	TABLE—dinette/double bed (w/RPO 692, 693, 695, 696)
-	1	1	+	715474	TABLE—dinette/double bed (w/RPO 690) (procure locally)
-	-	1		2000916	TABLE ASSY.—dinette (walnut) 2 leaf. (w/RPO 641, 681, 685, 697, 698) (incl. the following items as indicated)
-	-	1		2006658	TABLE ASSY.—dinette (finish similar to rosewood) (w/RPO 683) (incl. the following items as indicated)
-	-	1		791658	TABLE ASSY.—dinette, 2 leaf (incl. the following items as indicated) (w/RPO 681, 697) (exc./ZEO6584) (vehicles built prior to June 21, 1976)
-	-	6		796783	HINGE ASSY.—table (w/791658 & 2000916) (SOA)
-	-	1		796780	BRACKET ASSY.—leg, table (w/791658, 2000916 & 2006658) (SOA)
-	-	1		797300	LEG—table (w/791658, 2000916 & 2006658)
-	-	1		797299	SUPPORT—table, (stained wood) (w/791658 & 2000916)
-	-	1		796782	FERRULE—table leg (w/791658, 2000916 & 2006658)
-	-	4		796781	RING—table brass (w/791658, 2000916 & 2006658)
-	-	1		791914	CHANNEL—table, inner (att. to wall) (w/791658, 2000916 & 2006658)
-	-	1		791915	CHANNEL—table, outer (att. to table) (w/791658, 2000916 & 2006658)
-	-	4		2299512	RIVNUT—channel, table (w/791658)
-	1	1		715476	LEG—table, dinette/double bed (prior to 1975)
-	1	1		715478	BOARD—splash, table to wall (w/RPO 692, 693, 695, 696)
-	1	1	+	715477	BOARD—splash, table to wall (w/RPO 690)
-	AR	AR		716807	T—MOULDING—dinette table and splash board (25' rolls)
-	1	1		707969	HINGE ASSY.—dinette table to splash board
-	2	2	+	715705	CUSHION—dinette seat back (w/RPO 690)
-	2	2	+	715725	CUSHION—dinette seat (w/RPO 690)
-	2	2	+	715706	CUSHION—dinette seat back (w/RPO 692)
-	2	2	+	715726	CUSHION—dinette seat (w/RPO 692)
-	2	2	+	715707	CUSHION—dinette seat back (w/RPO 693)
-	2	2	+	715727	CUSHION—dinette seat (w/RPO 693)
-	2	2	+	715708	CUSHION—dinette seat back (w/RPO 695)
-	2	2	+	715729	CUSHION—dinette seat (w/RPO 695)
-	-	2	+	723354	CUSHION—dinette seat back (w/RPO 696)
-	-	2	+	723356	CUSHION—dinette seat (w/RPO 696)
-	2	2		715762	HINGE—seat access compartment, dinette/double bed
-	1	1		715831	KIT—front seat belt, dinette/double bed (prior to 1975)
-	2	-		715832	KIT—rear seat belt, dinette/double bed (prior to 1975)
-	-	2		715834	KIT—rear seat belt, dinette/double bed (repl. 715830) (prior to 1975)
-	-	2		2029287	KIT—seat belt, rear facing dinette (w/RPO 685)
-	-	2		2002841	KIT—seat belt, rear facing dinette (w/RPO 698)
-	-	1		2029286	KIT—seat belt, (in board) front facing dinette (w/RPO 685)
-	-	1		2029285	KIT—seat belt, (out board) front facing dinette (w/RPO 685)
-	-	1		2002842	KIT—seat belt, (inboard) front facing dinette (w/RPO 698)
-	-	1		2002843	KIT—seat belt, (outboard) front facing dinette (w/RPO 698)
-	-	1		793974	BELT ASSY.—rear facing dinette seat. (w/RPO 681, 697) (repl. 790381)
-	-	1		2027149	BELT ASSY.—rear facing dinette seat (w/RPO 641) (repl. 2010359)
-	-	1		2027150	BELT ASSY.—dinette seat outboard, front facing (w/RPO 641) (repl. 2010358)
-	-	1		793973	BELT ASSY.—dinette seat outboard, front facing (w/RPO 681, 683, 697) (repl. 792183)
-	-	1		793972	BELT ASSY.—dinette seat inboard, front facing (w/RPO 681, 683, 697) (repl. 792184)
-	-	1		2010357	BELT ASSY.—dinette seat inboard, front facing (w/RPO 641)
-	-	1		799256	LOCK ASSY.—seat, RH (SOA) (eff. w/1975)
-	-	1		2024098	LOCK ASSY.—seat, LH SOA (eff. w/1977)
-	-	2		799257	MECHANISM ASSY.—back, (LH) (SOA) (eff. w/1975)
-	-	2		799258	MECHANISM ASSY.—back, (RH) (SOA) (eff. w/1975)
-	-	1		2024759	PANEL ASSY.—front, floor to seat (SOA) (w/RPO 641)
-	-	2		2003765	PANEL—front, floor to seat (w/RPO 681)
-	-	1		2027549	PANEL ASSY.—trim, dinette (w/RPO 685) (eff. w/1977)
-	-	2		799259	PANEL—front, floor to seat (w/RPO 697)
-	-	2		2003771	PANEL—front, floor to seat (w/RPO 698)
-	-	4		799260	SPRING—back mechanism (eff. w/1975)
-	-	4		799261	SPRING—lock mechanism (eff. w/1975)
-	-	4		799262	GRIP—actuator (plastic) (eff. w/1975)

FURNISHINGS

KEY 230 260 PART NUMBER

28.136 DINETTE/DOUBLE BED (Cont.)

—	—	2	2024751	BUTTON—pivot (3/8) (w/RPO 64 1)
—	—	4	2003763	BUTTON—pivot (3/8) (w/RPO 68 1)
—	—	4	2029994	BUTTON—pivot (3/8) (w/RPO 685) (eff. w/1977)
—	—	4	799264	BUTTON—pivot (3/8) (w/RPO 697)
—	—	4	2003769	BUTTON—pivot (3/8) (w/RPO 698)
—	—	4	2024757	BUTTON—pivot (5/8) (w/RPO 64 1)
—	—	16	2003762	BUTTON—pivot (5/8) (w/RPO 68 1)
—	—	8	2029992	BUTTON—pivot (5/8) (w/RPO 685) (eff. w/1977)
—	—	16	799263	BUTTON—pivot (5/8) (w/RPO 697)
—	—	16	2003768	BUTTON—pivot (5/8) (w/RPO 698)
—	—	16	2024758	BUTTON—pivot (2 3/4) (w/RPO 64 1)
—	—	32	2003764	BUTTON—strap (2 3/4) (w/RPO 68 1)
—	—	32	2029993	BUTTON—strap (2-3/4) (w/RPO 685) (eff. w/1977)
—	—	32	799265	BUTTON—strap (2 3/4) (w/RPO 697)
—	—	32	2003770	BUTTON—strap (2 3/4) (w/RPO 698)

28.140 DINETTE/SINGLE BED—AUXILIARY

NOTE: “ + ” indicates not serviced, for reference only. See Group 28. 180 for raw material coverings.

—	—	1	+	715801	SEAT ASSY.—front, exc./cushion (w/RPO 690)
—	—	1	+	715803	SEAT ASSY.—rear, exc./cushion (w/RPO 690)
—	—	1	+	715802	SEAT ASSY.—front, exc./cushion (w/RPO 692, 693, 695)
—	—	1	+	715804	SEAT ASSY.—rear, exc./cushion (w/RPO 692, 693, 695)
—	—	2	—	—	CHANNEL—seat back to wall (procure locally) (ref. 715499)
—	—	AR	—	716808	T—MOULDING—seat back (25' rolls, CTL) (w/RPO 690)
—	—	AR	—	716809	T—MOULDING—seat back (25' rolls, CTL) (w/RPO 692, 693, 695, 696)
—	—	AR	—	716807	T—MOULDING—table and splash board (25' rolls)
—	—	1	+	715805	TABLE—auxiliary dinette (w/RPO 690)
—	—	1	—	715806	TABLE—auxiliary dinette (w/RPO 692, 693, 695)
—	—	1	—	715807	LEG—table, auxiliary dinette
—	—	1	+	715477	BOARD—splash, table to wall (w/RPO 690) (procure locally)
—	—	1	—	715478	BOARD—splash, table to wall (w/RPO 692, 693, 695)
—	—	1	—	707969	HINGE ASSY.—table to splash board
—	—	2	+	715701	CUSHION—dinette seat back (w/RPO 690)
—	—	2	+	715721	CUSHION—dinette seat (w/RPO 690)
—	—	2	+	715702	CUSHION—dinette seat back (w/RPO 692)
—	—	2	+	715722	CUSHION—dinette seat (w/RPO 692)
—	—	2	+	715703	CUSHION—dinette seat back (w/RPO 693)
—	—	2	+	715723	CUSHION—dinette set (w/RPO 693)
—	—	2	+	715704	CUSHION—dinette seat back (w/RPO 695)
—	—	2	+	715724	CUSHION—dinette seat (w/RPO 695)
—	—	1	—	715831	KIT—front seat belt, auxiliary dinette
—	—	1	—	715834	KIT—rear seat belt, auxiliary dinette (repl. 715830)

28.142 SEAT—LOVE

—	—	1	—	2006618	SEAT ASSY.—love (complete) (w/RPO 683)
—	—	1	—	2013207	FRAME ASSY.—love seat
—	—	1	—	2013214	CUSHION ASSY.—bottom (w/RPO 64 1)
—	—	1	—	2024087	CUSHION ASSY.—bottom (w/RPO 683)
—	—	1	—	2013208	CUSHION ASSY.—bottom (w/RPO 697)
—	—	1	—	2013211	CUSHION ASSY.—bottom (w/RPO 698)
—	—	1	—	2013215	CUSHION ASSY.—back (w/RPO 64 1)
—	—	1	—	2024088	CUSHION ASSY.—back (w/RPO 683)
—	—	1	—	2013209	CUSHION ASSY.—back (w/RPO 697)
—	—	1	—	2013212	CUSHION ASSY.—back (w/RPO 698)
—	—	1	—	—	PANEL ASSY.—trim (see grp. 28. 176)

28.144 SWIVEL LOUNGE SEATS AND AIR CRAFT TABLE

NOTE: “ + ” indicates not serviced, for reference only. See Group 28. 180 for raw material covering.

FURNISHINGS

KEY 230 260 PART NUMBER

28.144 SWIVEL LOUNGE SEATS AND AIR CRAFT TABLE (Cont.)

—	—	2	701538	SEAT—swivel lounge (w/RPO 690)
—	—	2	723367	SEAT—swivel lounge (flexsteel) (w/RPO 690)
—	—	2	701537	SEAT—swivel lounge (w/RPO 692)
—	—	2	723368	SEAT—swivel lounge (flexsteel) (w/RPO 692)
—	—	2	704787	SEAT—swivel lounge (w/RPO 693)
—	—	2	723369	SEAT—swivel lounge (flexsteel) (w/RPO 693)
—	—	2	701539	SEAT—swivel lounge (w/RPO 695)
—	—	2	723371	SEAT—swivel lounge (flexsteel) (w/RPO 695)
—	—	2	+	723353 SEAT—swivel (w/RPO 696)
—	—	2	+	723361 SEAT—swivel lounge (flexsteel) (w/RPO 696)
—	—	2	2010351	SEAT ASSY.—swivel chair (w/RPO 641)
—	—	2	796722	SEAT ASSY.—swivel chair (w/RPO 681)
—	—	2	799320	SEAT ASSY.—swivel chair (w/RPO 697)
—	—	2	2000936	SEAT ASSY.—swivel chair (w/RPO 698)
—	—	2	701638	ADJUSTER—seat (incl. next 3 items)
—	—	2	709113	SPRING—handle return, seat adjuster
—	—	1	709114	CLIP—connecting wire, seat adjuster
—	—	2	793692	WIRE—connecting latch, seat adjuster (repl. 709115 & 709116)
—	—	2	717661	PEDESTAL—seat (incl. round pipe) (prior to 1975)
—	—	2	796720	PEDESTAL ASSY.—chair (complete) (w/RPO 's 681, 697) (eff. w/1975)
—	—	2	2000935	PEDESTAL ASSY.—chair (complete) (w/RPO 698) (eff. w/1975)
—	—	2	2010348	PEDESTAL ASSY.—chair (complete) (w/RPO 641)
—	—	8	9426323	BOLT—pedestal to floor (300M) (eff. w/1975)
—	—	8	—	SPACER—pedestal, bolt thru floor (eff. w/1975) (make locally) (ref. 2000567)
—	—	8	701805	PLATE ASSY.—anchor, seat (eff. w/1975)
—	—	2	723350	SHROUD—swivel seat pedestal (w/RPO 696)
—	—	2	717356	SHROUD—inner and outer (prior to 1975)
—	—	2	717357	SPACER—seat (wood) (prior to 1975)
—	—	12	717358	PLATE—seat mounting (prior to 1975)
—	—	1	+	717361 CABINET AND TABLE ASSY.—aircraft, complete (w/RPO 690)
—	—	1	+	717359 CABINET AND TABLE ASSY.—aircraft, complete (w/RPO 692, 693, 695, 696)
—	—	1	+	717362 TABLE—aircraft, w/T—moulding, w/out cabinet (w/RPO 690)
—	—	1	+	717360 TABLE—aircraft, w/T—moulding, w/out cabinet (w/RPO 692, 693, 695, 696)
—	—	1	796718	TABLE ASSY.—captains (rosewood) (vehicles built prior to June 21, 1976) (w/RPO 's 681, 697)
—	—	1	2001376	TABLE—captains (walnut) (w/RPO 697, 698) vehicles built after June 21, 1976) (details not available at time of publication)
—	—	1	2001884	LABEL—forward, seat facing (decal)
—	—	1	2002026	LABEL—rearward, seat facing (decal)
—	—	AR	716808	T—MOULDING—aircraft table, trim (w/RPO 690) (25' rolls, CTL)
—	—	AR	716809	T—MOULDING—aircraft table, trim (w/RPO 692, 693, 695, 696) (25' rolls, CTL)
—	—	1	715833	KIT—belt, swivel lounge seat (front, to step riser) (prior to 1975)
—	—	1	715834	KIT—belt, swivel lounge seat (rear, to floor) (prior to 1975)
—	—	2	793973	BELT KIT—seat, swivel chair (w/RPO 's 681, 697) (eff. w/1975)
—	—	2	2002843	BELT KIT—seat, swivel chair (repl. 2000677) (w/RPO 698) (eff. w/1975)
—	—	2	2027150	BELT ASSY.—seat, swivel chair (w/RPO 641) (repl. 2010358)
—	—	2	720008	BOLT—anchor, belt (step to riser) (eff. w/1975)
—	—	2	9417033	BOLT—anchor, belt (to floor) (300M) (eff. w/1975)
—	—	4	2436165	WASHER—bolt (eff. w/1975)
—	—	1	799816	PANEL—duct, trim (covers transitions) (w/RPO 681, 697)
—	—	1	2001121	PANEL—duct, trim (covers transitions) (w/RPO 698)
—	—	1	2001884	LABEL—seat facing forward (decal)
—	—	1	2002026	LABEL—seat facing rearward (decal)

28.148 TABLE—DRIVER'S COMPARTMENT

—	1	1	796570	TABLE—driver's compartment (complete) (w/RPO 690, 692, 693, 695, 696) (repl. 715563)
—	1	1	715564	SUPPORT—table to instrument panel (w/715563)
—	1	1	723339	TABLE LEG—driver's compartment (w/715563)

FURNISHINGS

KEY 230 260 PART NUMBER

28.148 TABLE—DRIVER'S COMPARTMENT (Cont.)

—	—	1	2030283	TABLE ASSY.—driver's compartment (w/RPO ENF) (w/ZEO6581) (1978) (incl. next (2) items)
—	—	1	715470	CAP—driver's table leg end (mounts to driver's table)
—	—	1	796781	RING—driver's table
—	—	1	2029940	CAP—recessed leg end (mounts to floor under carpet)
—	—	1	2029944	LEG—driver's table (w/RPO ENF)
—	—	1	796570	TABLE ASSY.—driver's (w/RPO 681, 697) (SOA) (vehicles built prior to June 21, 1976)
—	—	1	2004497	TABLE ASSY.—drivers compartment (w/RPO 698) (eff. w/1977)
—	—	1	795262	TABLE ASSY.—drivers (pecan) (w/cut outs for drinking glasses) (w/RPO 641, 697, ENF) (SOA) (eff w/1977)
—	—	1	2001312	TABLE ASSY.—driver's
—	—	4	2004761	SPACER—retainer to table anchor
—	—	1	796569	RETAINER—driver's table to instrument panel (w/796570, 2001312)
—	—	1	796572	BRACKET—mounting, drivers table (w/795262, 2004497 table)
—	—	4	798396	ANCHOR—nylon, retainer to instrument panel (w/796570, 2001312)
—	—	1	796568	STRIP—trim insert (rosewood) (w/RPO 681, 697) (vehicles built prior to June 21, 1976)
—	—	1	2001311	STRIP—insert trim (walnut) (w/RPO 641, 681, 697, 698) (vehicles built after June 21, 1976)

28.152 SIDE FACING SETTEE/DOUBLE BED AND REAR DINING TABLE

NOTE: " + " indicates not serviced, for reference only. See Group 28.180 for raw material coverings.

—	2	2	798366	BACK—seat (w/RPO 690) (repl. 717347)
—	1	1	+ 715738	CUSHION—seat, RH (w/RPO 690)
—	1	—	+ 715750	CUSHION—seat, LH (w/RPO 690)
—	—	1	+ 715734	CUSHION—seat, LH (w/RPO 690)
—	2	2	798362	BACK—seat (w/RPO 692) (repl. 717348)
—	1	1	+ 715739	CUSHION—seat, RH (w/RPO 692)
—	1	—	+ 715794	CUSHION—seat, LH (w/RPO 692)
—	—	1	+ 715735	CUSHION—seat, LH (w/RPO 692)
—	2	2	798367	BACK—seat (w/RPO 693) (repl. 717349)
—	1	1	+ 715740	CUSHION—seat, RH (w/RPO 693)
—	1	—	+ 715795	CUSHION—seat, LH (w/RPO 693)
—	—	1	+ 715736	CUSHION—seat, LH (w/RPO 693)
—	2	2	798368	BACK—seat (w/RPO 695) (repl. 717350)
—	1	1	+ 715741	CUSHION—seat, RH (w/RPO 695)
—	1	—	+ 715796	CUSHION—seat, LH (w/RPO 695)
—	—	1	+ 715737	CUSHION—seat, LH (w/RPO 695)
—	—	1	2010336	CUSHION—rear trim, at rear window (w/RPO 641)
—	—	1	794549	CUSHION—rear trim, at rear window (w/RPO 681)
—	—	1	2027554	CUSHION—rear trim, at rear window (w/RPO 685)
—	—	1	792151	CUSHION—rear trim, at rear window (w/RPO 697)
—	—	1	2000659	CUSHION—rear trim, at rear window (w/RPO 698)
—	—	2	2010341	SEAT ASSY.—side facing settee, (complete seat) (w/RPO 641) (prior to 1978) (ref. only)
—	—	2	2028523	SEAT ASSY.—side facing settee, (complete seat) (w/RPO 641) (1978) (repl. 2010341)
—	—	2	794545	SEAT ASSY.—side facing settee, (complete seat) (w/RPO 681)
—	—	2	2027547	SEAT ASSY.—side facing settee, (complete seat) (w/RPO 685)
—	—	2	790306	SEAT ASSY.—side facing settee, (complete seat) (w/RPO 697) (prior to 1978) (ref. only)
—	—	2	2028583	SEAT ASSY.—side facing settee, (complete seat) (w/RPO 697) (1978) (repl. 790306) (details not available at time of publication)
—	—	2	2000654	SEAT ASSY.—side facing settee, (complete seat) (w/RPO 698) (prior to 1978) (ref. only)
—	—	2	2028522	SEAT ASSY.—side facing settee, (complete seat) (w/RPO 698) (1978) (repl. 2000654)
—	—	1	2024764	BACK—settee upper (complete) (SOA) (w/RPO 641)
—	—	2	2003782	BACK—settee upper (complete) (SOA) (w/RPO 681)
—	—	1	2030937	BACK ASSY.—settee upper (complete) (SOA) (w/RPO 685)
—	—	2	799266	BACK—settee upper (complete) (SOA) (w/RPO 697)
—	—	2	2003786	BACK—settee upper (complete) (SOA) (w/RPO 698)

FURNISHINGS

KEY 230 260 PART NUMBER

**28.152 SIDE FACING SETTEE/DOUBLE BED AND REAR DINING TABLE
(Cont.)**

-	-	1	2024767	SEAT—settee (complete) (SOA) (w/RPO 641)
-	-	2	2003783	SEAT—settee (complete) (SOA) (w/RPO 681)
-	-	1	2030939	SEAT ASSY.—settee (complete) (SOA) (w/RPO 685)
-	-	2	799267	SEAT—settee (complete) (SOA) (w/RPO 697)
-	-	2	2003787	SEAT—settee (complete) (SOA) (w/RPO 698)
-	2	4	796796	REST—arm, (w/RPO 690)
-	2	4	796797	REST—arm, (w/RPO 692)
-	2	4	796798	REST—arm, (w/RPO 693)
-	2	4	796799	REST—arm, (w/RPO 695)
-	2	-	796800	REST—arm, LH (w/RPO 690)
-	2	-	797152	REST—arm, LH (w/RPO 692)
-	2	-	797153	REST—arm, LH (w/RPO 693)
-	2	-	797154	REST—arm, LH (w/RPO 695)
-	-	1	-	PANEL—settee lower RH/LH (see group 28.176)
-	-	2	791984	ANCHOR—settee seat, rear (aluminum angle) (w/790306)
-	-	1	791985	ANCHOR—settee seat, front (aluminum angle) (w/790306)
-	-	4	700368	RIVET—settee front anchor (LH) (grip range .437)
-	2	2	796318	LINKAGE ASSY.—settee, rear RH side front & LH side rear (prior to 1975)
-	2	2	796323	LINKAGE ASSY.—settee, rear LH side rear & RH side front (prior to 1975)
-	1	1	715468	TABLE—rear dining (w/RPO 690)
-	1	1	+ 715469	TABLE—rear dining (w/RPO 692, 693, 695)
-	-	1	796717	TABLE ASSY.—rear dining (incl. table & upper support cap only) (vehicles built prior to June 21, 1976) (w/RPO 681, 697)
-	-	1	2001350	TABLE ASSY.—rear dining (incl. table & upper support cap only) (w/RPO 641, 698) (walnut)
-	-	1	2001350	TABLE ASSY.—rear dining (incl. table & upper support cap only) (w/RPO 697) (vehicles built after June 21, 1976)
-	AR	AR	716807	T—MOULDING—rear dining table (prior to 1975)
-	-	1	796795	LEG—rear table (eff. w/1975)
-	1	1	715575	SUPPORT—rear dining table (leg) (prior to 1975)
-	1	1	715470	CAP—lower table support (leg)
-	-	1	799257	MECHANISM ASSY.—settee, LH (linkage) (SOA) (eff. w/1975)
-	-	1	799258	MECHANISM ASSY.—settee, RH (linkage) (SOA) (eff. w/1975)
-	-	4	799268	SPRING—linkage (eff. w/1975)
-	-	4	799262	GRIPS—release, plastic (eff. w/1975)
-	-	4	2003762	BUTTON—pivot (5/8") (w/RPO 681)
-	-	8	799263	BUTTON—pivot (5/8") (w/RPO 685)
-	-	4	799263	BUTTON—pivot (5/8") (w/RPO 697)
-	-	4	2003768	BUTTON—pivot (5/8") (w/RPO 698)
-	-	16	2024758	BUTTON (2 3/4") (w/RPO 641)
-	-	32	2003764	BUTTON—strap (2 3/4") (w/RPO 681)
-	-	8	799265	BUTTON—pivot (2 3/4") (w/RPO 685)
-	-	32	799265	BUTTON—strap (2 3/4") (w/RPO 697)
-	-	32	2003770	BUTTON—strap (2 3/4") (w/RPO 698)

28.154 CLOSURE—HEATER

-	-	1	791848	CLOSURE—rear heater (LH) (52 3/4" x 18" x 5") (rosewood) (trim panel) (w/RPO 681, 697) (vehicles built prior to June 21, 1976)
-	-	1	2008299	CLOSURE—rear heater (LH) (rosewood) (trim panel) (w/RPO 683)
-	-	1	2000329	CLOSURE ASSY.—rear heater (52 3/4" x 18" x 5") (walnut) (trim panel) (w/RPO 641, 681, 685, 697 & 698) (exc. /ZE06584) (LH) (vehicles built after June 21, 1976)
-	-	1	2014618	CLOSURE ASSY.—rear heater (trim panel) (w/RPO 641 & w/ZEO6584) 697, 698) (ref. only)
-	-	2	NPN	BRACKET—heater closure to car line (eff. w/1975) (ref. 792171) (make locally)
-	-	1	2240368	BRACKET—heater closure to MG box (eff. w/1975) (repl. 792169, 2000762)
-	AR	AR	2013358	BOARD—particle, service (.50 x 48.0 x 96.0") (rosewood grain)
-	AR	AR	2013359	BOARD—particle, service (.50 x 48.0 x 96.0") (walnut grain)

FURNISHINGS

KEY 230 260 PART NUMBER

28.155 LOCKER—BEDDING

—	—	1	791849	LOCKER ASSY.—bedding (w/RPO 681, 697) (53.75 lg. x 17.75) (rosewood) (vehicles built prior to June 21, 1976)
—	—	1	2000330	LOCKER ASSY.—bedding (w/RPO 641, 681, 685, 697, 698) (53.75 lg. x 17.75) (walnut) (vehicles built after June 21, 1967)
—	2	2	715762	HINGE—bed locker (prior to 1975)
—	—	2	715760	HINGE ASSY.—bed locker (eff. w/1975)
—	—	1	791850	HANDLE—flush, pull ring (brass) (eff. w/1975)
—	AR	AR	2013358	BOARD—particle service (.50 x 48.0 x 96.0'') (rosewood grain)
—	AR	AR	2013359	BOARD—particle, service (.50 x 48.0 x 96.0'') walnut grain)

28.156 BED—PERMANENT

NOTE: " + " indicates not serviced, for reference only. See Group 28.180 for raw material coverings.

—	1	—	+	715746	ATTRESS—permanent bed (w/RPO 690)
—	1	—	+	715747	MATTRESS—permanent bed (w/RPO 692)
—	1	—	+	715748	MATTRESS—permanent bed (w/RPO 693)
—	1	—	+	715749	MATTRESS—permanent bed (w/RPO 695)
—	—	1	+	715713	MATTRESS—permanent bed (w/RPO 690)
—	—	1	+	715714	MATTRESS—permanent bed (w/RPO 692)
—	—	1	+	715715	MATTRESS—permanent bed (w/RPO 693)
—	—	1	+	715716	MATTRESS—permanent bed (w/RPO 695)

28.158 BED—TWIN

—	—	1		2013223	BOLSTER—(pillow) back, rear RH (w/RPO BRV & 641)
—	—	1		2007791	BOLSTER—(pillow) back, rear RH (w/RPO BRV & 683)
—	—	1		2013229	BOLSTER—(pillow) back, rear RH (w/RPO BRV & 697)
—	—	1		2013241	BOOSTER—(pillow) back, rear RH (w/RPO BRV & 698)
—	—	1		2013222	BOLSTER—(pillow) back, rear LH (w/RPO BRV & 641)
—	—	1		2007792	BOLSTER (pillow) back, rear LH (w/RPO BRV & 683)
—	—	1		2013228	BOLSTER—(pillow) back, rear LH (w/RPO BRV & 697)
—	—	1		2013240	BOLSTER—(pillow) back, rear LH (w/RPO BRV & 698)
—	—	4		2013220	BOLSTER—(pillow) back, side (w/RPO BRV & 641)
—	—	4		2007793	BOLSTER (pillow) back, side (w/RPO BRV & 683)
—	—	4		2013226	BOLSTER—(pillow) back, side (w/RPO BRV & 697)
—	—	4		2013234	BOLSTER—(pillow) back, side (w/RPO BRV & 698)
—	—	1		2013219	CUSHION ASSY.—LH, seat (w/RPO 641)
—	—	1		2006628	CUSHION ASSY.—LH, seat (w/RPO 683)
—	—	1		2013225	CUSHION ASSY.—LH, seat (w/RPO 697)
—	—	1		2013231	CUSHION ASSY.—LH, seat (w/RPO 698)
—	—	1		2013217	CUSHION ASSY./—RH, seat (w/RPO 641)
—	—	1		2006632	CUSHION ASSY.—RH, seat (w/RPO 683)
—	—	1		2013224	CUSHION ASSY.—RH, seat (w/RPO 697)
—	—	1		2013230	CUSHION ASSY.—RH, seat (w/RPO, 698)
—	—	1		2008059	SUPPORT ASSY.—LH, twin bed (frame) (w/ZEO6582)
—	—	1		2008144	SUPPORT ASSY.—RH, twin bed (frame) (w/ZEO6582)
—	—	1		2014903	SUPPORT ASSY.—LH twin bed (frame) (w/ZEO 6584)
—	—	1		2014905	SUPPORT ASSY.—RH twin bed (frame) (w/ZEO 6584)
—	—	1		2009457	BRACKET—support, twin bed

28.160 BED—GAUCHO/DOUBLE

NOTE: " + " indicates not serviced, for reference only. See Group 28.180 for raw material coverings.

—	1	1	+	715709	CUSHION—back (w/RPO 690)
—	1	1	+	715730	CUSHION—seat (w/RPO 690)
—	1	—	+	715742	CUSHION—utility seat (w/RPO 690)
—	—	1	+	715797	CUSHION—utility seat (w/RPO 690)
—	1	1	+	715710	CUSHION—back (w/RPO 692)
—	1	1	+	715731	CUSHION—seat (w/RPO 692)
—	1	—	+	715798	CUSHION—utility seat (w/RPO 692)
—	—	1	+	715743	CUSHION—utility seat (w/RPO 692)

FURNISHINGS

KEY 230 260 PART NUMBER

28.160 BED—GAUCHO/DOUBLE (Cont.)

-	1	1	+	715711	CUSHION—back (w/RPO 693)
-	1	1	+	715732	CUSHION—seat (w/RPO 693)
-	1	-	+	715799	CUSHION—utility seat (w/RPO 693)
-	-	1	+	715744	CUSHION—utility seat (w/RPO 693)
-	1	1	+	715712	CUSHION—back (w/RPO 695)
-	1	1	+	715733	CUSHION—seat (w/RPO 695)
-	1	-	+	715800	CUSHION—utility seat (w/RPO 695)
-	-	1	+	715745	CUSHION—utility seat (w/RPO 695)
-	-	1	+	723355	CUSHION—back (w/RPO 696)
-	-	1	+	723357	CUSHION—seat (w/RPO 696)
-	-	1	+	723358	CUSHION—utility seat (w/RPO 696)
-	-	1	+	723359	CUSHION—bed locker side (w/RPO 696)
-	-	1	+	723360	CUSHION—utility side (w/RPO 696)
-	3	3		NS	HINGE—gaucho seat (piano hinge) (ref. 715471)
-	1	1		715762	HINGE—reinforcement, gaucho seat
-	2	2		NS	BRACKET—roller mounting, gaucho seat (ref. 717363)
-	2	2		717364	ROLLER—gaucho seat

28.162 DRESSER—REAR

-	-	1		2008045	DRESSER ASSY.—rear (w/RPO 683) (w/ZE06582)
-	-	1		2014891	DRESSER ASSY.—rear (w/RPO 641, 697, 698) (w/ZE06584)
-	-	1		2018493	DRAWER ASSY.—rear upper SOA (w/RPO 641, 697, 698) (w/ZE06584)
-	-	1		2018492	DRAWER ASSY.—rear lower SOA (w/RPO 641, 697, 698) (w/ZE06584)
-	-	1		791192	SLIDE ASSY.—drawer (w/RPO 641, 697, 698) (w/ZE06584)
-	-	4		791193	GUIDE—drawer (w/RPO 641, 697, 698) (w/ZE06584)
-	-	6		-	BUMPER—drawer (w/RPO 641, 697, 698) (w/ZE06584) (ref. 791657) (proc. loc.)
-	-	1		2018494	DOOR—rear dresser (w/RPO 641, 697, 698) (w/ZE06584)
-	-	2		799288	BRACKET—dresser support
-	-	AR		2006744	DRAWER—(14.12" x 3.50" x 18.50) (w/RPO 683) (w/ZE6582)
-	-	AR		2006746	DRAWER—(17.12" x 5.25" x 18.50) (w/RPO 683) (w/ZE06582)
-	-	AR		2006747	KIT—drawer mtg. (RPO 683) (w/ZE06582)

28.164 CLOSET—BROOM/VACUUM SWEEPER

NOTE: " + " indicates not serviced, for reference only. See Group 28.180 for raw material coverings. (items marked w/asterisk are part of refrigerator modul

-	-	1		2028110	RACK ASSY.—glass & spice (w/RPO ENT) (eff. w/1978)
-	-	4		-	SCREW—glass & spice rack mounting (ref. 145135) (proc. loc.) (8-18 x 5/8) (round head slotted tapping)
-	-	1	+	715755	DOOR—broom and vacuum closet (green) (w/RPO 690)
-	-	1	+	715756	DOOR—broom and vacuum closet (gold) (w/RPO 692, 695)
-	-	1		NPN	DOOR—broom and vacuum closet (blue) (w/RPO 693) (procure locally)
-	-	1	*	2018498	DOOR—broom and vacuum closet (w/RPO 681, 697) (w/ZE06581) (rosewood)
-	-	1	*	2018491	DOOR—broom and vacuum closet (w/RPO 641, 697, 698) (std.) (w/ZE06584) (walnut) (16.41" x 36.90")
-	-	1		2026146	DOOR—broom and vacuum closet (w/RPO 641, 681, 697, 698) (w/ZE06581) (walnut)
-	-	1		715758	HINGE—door, broom and vacuum closet (piano hinge)
-	-	3	*	797220	HINGE—broom closet door (eff. w/1975) (repl. 791678)
-	-	1		790358	LATCH ASSY.—broom closet door (eff. w/1975) (First Design)
-	-	1	*	2000392	LATCH ASSY.—broom closet door (push type) (eff. w/1975) (Second Design)
-	-			790096	LATCH—broom closet retainer (eff. w/1975)
-	-			715759	LATCH—door, broom and vacuum closet (prior to 1975)
-	-			715763	STRIKER—latch, broom and vacuum closet door (prior to 1975)
-	-	1		790097	STRIKER—broom closet door (eff. w/1975)
-	-	1		2234775	EXTINGUISHER ASSY.—(incl. Strap & Bracket) (repl. 791178)
-	-	12	*	797216	SCREW—hinge, broom closet door
-	-	10	*	797217	SCREW—hinge, access door



FURNISHINGS

KEY 230 260 PART NUMBER

28.168 MODULE—REFRIGERATOR

NOTE: " + " indicates not serviced, for reference only. See Group 28.180 for raw material coverings.

—	—	1		2000332	MODULE ASSY.—refrigerator (walnut) (w/RPO 641, 681, 685, 697, 698) (w/ZEO6581) (vehicles built after June 21, 1976) (prior to 1978) (incl. respective item marked with asterisk)
—	—	1		2029349	MODULE ASSY.—refrigerator (walnut) (w/RPO 641, 685, 697, 698) (w/ZEO6581) (eff. w/1978)
—	—	1		2013568	MODULE ASSY./—refrigerator (walnut) (w/RPO 641, 697, 698) (w/ZEO6584) (std.) (ref. only) (includes respective items marked with asterisk)
—	—	1		791826	MODULE ASSY.—refrigerator (Rosewood) (w/RPO 681, 697) (w/ZEO6581) (ref. only) (vehicles built prior to June 21, 1976) (includes respective items marked with asterisk)
—	—	1		2008039	MODULE ASSY.—refrigerator (rosewood) (w/RPO 683) (w/ZEO6582) (includes respective items marked with asterisk) (ref. only)
—	AR	AR	+	NS	DOOR—top and bottom access (w/RPO 690, 692, 693, 695, 696)
—	—	2	*	2018489	DOOR—cabinet, refrigerator, top access (11.68" x 14.12") (plain) (rosewood) (w/RPO 683) (w/ZEO6582)
—	—	2	*	2018490	DOOR—cabinet, refrigerator, top access (11.68" x 14.12") (plain) (walnut) (w/RPO 641, 697, 698) (std.) (w/ZEO6584)
—	—	2	*	2018488	DOOR—cabinet, refrigerator bottom access (11.68" x 13.50") (plain) (rosewood) (w/RPO 683) (w/ZEO6582)
—	—	2	*	2018487	DOOR—cabinet, refrigerator bottom access (11.68" x 13.50") (plain) (walnut) (w/RPO 641, 697, 698) (std.) (w/ZEO6584)
—	—	2	*	2025496	DOOR—cabinet, refrigerator, bottom access (w/RPO 641, 681, 697, 698) walnut (w/ZEO6581)
—	1	1		795614	DOOR—cabinet, refrigerator, bottom access (24.58" x 15.42") (carved) (w/RPO 692, 693, 695, 696)
—	1	1		795618	DOOR—cabinet, refrigerator, bottom access (22.74" x 15.44") (carved) (w/RPO 692, 693, 695, 696)
—	—	1	*	2018497	DOOR—Cabinet, refrig. bottom access (rosewood) (w/RPO 681, 697) (w/ZEO6581) (RH & LH)
—	1	—		795615	DOOR—cabinet, refrigerator, top (22.69" x 12.80") (carved) (w/RPO 692, 693, 695)
—	—	1		795616	DOOR—cabinet, refrigerator, top (22.69" x 12.80") (carved) (w/RPO 692, 693, 695, 696)
—	1	—		795617	DOOR—cabinet, refrigerator, top (16.56" x 15.44") (carved) (w/RPO 692, 693, 695)
—	—	1		795619	DOOR—cabinet, refrigerator, top (22.74" x 15.44") (carved) (w/RPO 692, 693, 695, 696)
—	AR	AR	+	NS	PANEL—insert, refrigerator trim (w/RPO 690, 692, 693, 695)
—	—	1		790093	PANEL—insert, refrigerator trim (top) (w/RPO 681, 697, 698) (exc./ZEO6584)
—	—	1		—	PANEL—insert, refrigerator trim (top) (w/RPO 641) (exc./ZEO6584) (make locally) (ref 2009883)
—	—	1		—	PANEL—insert, refrigerator trim (bottom) (w/RPO 641) (exc./ZEO6584) (make locally) (ref 2009882)
—	—	1		2014307	PANEL—trim refrigerator (w/RPO 641, & ZEO6584)
—	—	1		2014308	PANEL—trim refrigerator (w/RPO 697, 698 & ZEO6584)
—	—	1		790094	PANEL—insert, refrigerator trim (bottom) (w/RPO 681, 697, 698) (exc./ZEO6584)
—	—	1		2007918	PANEL—insert, refrigerator trim (w/RPO 683)
—	—	1	*	790898	PANEL—refrigerator accent (w/RPO 681, 697, 698) (exc./ZEO6584)
—	AR	AR		716805	MOULDING—bulkhead to wall (25' roll, CTL)
—	—	2		715760	HINGE—refrigerator, upper access door w/6 cu. ft. all electric (prior to 1975)
—	2	2		715761	HINGE—refrigerator, bottom access door (prior to 1975)
—	—	1	*	797218	HINGE—lower door (RH) (bronze) (eff. w/1975) (prior to interm 1977)
—	—	1	*	797219	HINGE—lower door (LH) (bronze) (eff. w/1975) (prior to interm 1977)
—	—	1		2024881	HINGE—lower door (RH/LH) (eff. w/interm 1977)
—	—	4	*	2006749	HINGE—door LH refrigerator (eff. w/1977) (antique copper)
—	—	4	*	2006748	HINGE—door RH refrigerator (eff. w/1977) (antique copper)
—	—	1	*	791699	CATCH ASSY.—refrigerator module lower door (eff. w/1975) (prior to 1977)
—	—	4		2026184	CATCH ASSY.—door (eff. w/1977)

FURNISHINGS

KEY 230 260 PART NUMBER

28.168 MODULE—REFRIGERATOR (Cont.)

—	AR	AR	711466	LATCH—refrigerator cabinet access door
—	—	2	2029465	SEAL—refrigerator module lower vent
—	—	1	2029464	SEAL—refrigerator module upper vent
—	—	1	791965	INSULATION—refrigerator module
—	—	4	* 790098	BRACKET—retainer, refrigerator
—	—	1	790096	RETAINER—latch, door (eff. w/1975)
—	—	3	* —	HINGE—broom closet door (see group 28.164)
—	—	1	—	LATCH—door (see group 28.164)
—	—	1	—	STRIKER—door (see group 28.164)
—	—	4	* NS	BUMPER—door (procure locally)
—	—	1	791818	BRACKET—mounting, module (eff. w/1975)
—	—	2	* 799288	BRACKET—mounting, module (eff. w/1975) (repl. 791817)
—	—	2	—	SCREW—refrigerator to retainer (ref. 9414717)
—	—	4	* 2436162	WASHER—mounting bracket
—	—	12	* —	SCREW—hinge, broom closet door (see group 28.164)
—	—	10	* —	SCREW—hinge, access door (see group 28.164)
—	—	4	—	BRACKET—mtg., refrigerator (make locally) (ref. 2008936) (w/ZE06582)
—	—	8	2000322	SCREW—bracket—, refrigerator mtg. (w/ZE06582, ZE06584)
—	AR	AR	* 2013358	BOARD—particle, service (.50 x 48.0 x 96.0) (rosewood grain)
—	AR	AR	2013359	BOARD—particle, service (.50 x 48.0 x 96.0) (walnut grain)
—	—	1	2010595	SEAL—refrigerator module (w/ZE06584)
—	—	1	9686320	STRAP—entrance door assist handle
—	—	2	9685807	COVER—entrance door assist handle

NOTE: Asterisk (*) indicates part of above Module

28.172 MODULE—BATHROOM

NOTE: " + " indicates not serviced, for reference only. See Group 28.180 for raw material coverings.

—	—	1	791822	MODULE ASSY.—bath (w/RPO 681, 697) (ref. only) (includes items marked with asterisk) (vehicles built prior to June 21, 1976)
—	—	1	2000331	MODULE ASSY.—bath (w/RPO 681, 685, 697) (ref. only) (exc./ZE06584) (vehicles built after June 21, 1976) (prior to 1978) (includes respective items marked with asterisk)
—	—	1	2000331	MODULE ASSY.—bath (w/RPO 641, 698) (ref. only) (exc./ZE06584) (prior to 1978) (includes respective items marked with asterisk)
—	—	1	2030660	MODULE ASSY.—bath (w/RPO 641, 685, 697, 698) (w/ZE06581) (1978) (includes respective items marked with asterisk)
—	—	1	2008037	MODULE ASSY.—bath & shower (w/RPO 683) (ref. only)
—	—	1	2014621	MODULE ASSY.—bath & shower (w/ZE06584 & w/RPO 641, 697, 698) (ref. only)

NOTE: Bath module assemblies 2008037 & 2014621 include the following item only.

—	—	1	2041238	SINK—bath vanity top
—	1	1	716842	DOOR ASSY.—bath (w/RPO 690) (repl. 715495)
—	1	1	+ 716843	DOOR ASSY.—bath (w/RPO 692, 693, 695, 696) (repl. 715496)
—	—	1	* 790350	DOOR ASSY.—bath (w/RPO 681, 697) (exc./ZE06584) (vehicles built prior to June 21, 1976)
—	—	1	* 2000374	DOOR ASSY.—bath (w/681, 697) (exc./ZE06584) (vehicles built after June 21, 1976)
—	—	1	* 2000374	DOOR ASSY.—bath (w/RPO 641, 698) (exc./ZE06584)
—	—	1	2008968	DOOR ASSY.—bath (w/ZE06582)
—	—	1	* 2025491	PANEL—front (w/ZE06581) (1978)
—	—	1	* 2025492	PANEL—LH (w/ZE06581) (1978)
—	—	1	790377	STOP—door, bath (at galley)
—	1	1	* 2003710	LATCH—bath door (repl. 711465, 716120)
—	1	1	716121	STRIKER—bath door latch (w/2003710 latch)
—	3	3	* 715492	HINGE—bath door
—	1	1	* 794994	TRACK—shower curtain (above sink) (repl. 717351)
—	2	2	—	DOOR—vanity cabinet (w/RPO 690) (procure locally)
—	2	2	—	DOOR—vanity cabinet (w/RPO 693) (procure locally)

FURNISHINGS

KEY 230 260 PART NUMBER

28.172 MODULE—BATHROOM (Cont.)

—	—	1	791174	DOOR—vanity cabinet (gold) (16.50" x 12.31") (w/RPO 681, 692, 695, 697) (exc./ZEO6584)
—	—	2	2000328	DOOR—vanity cabinet (apple green) (16.50" x 12.31") (w/RPO 698) (exc./ZEO6584)
—	—	2	2007607	DOOR—vanity cabinet (burnt orange) (16.88" x 11.12") (w/RPO 641, 683 & ZEO6582, ZEO6584)
—	—	2	2018410	DOOR—vanity cabinet (burnt orange) (16.50" x 12.31") (w/RPO 641 & ZEO6581) (eff. w/1977)
—	—	2	2014309	DOOR—vanity cabinet (gold) (16.88" x 11.12") (w/RPO 697 & ZEO6584)
—	—	2	2014306	DOOR—vanity cabinet (apple green) (16.88" x 11.12") (w/RPO 698 & ZEO6584)
—	—	2	2027937	DOOR—vanity cabinet (w/RPO 685)
—	—	1	791844	LINER—vanity cabinet (plastic) (below sink) (tissue holder attaches to part)
—	—	2	* 791173	FRAME ASSY.—medicine and vanity cabinet
—	—	4	791194	SLIDE—insert/medicine and vanity cabinet (plastic)
—	—	24	—	RIVET—vanity (ref. 791191)
—	1	1	NS	STOP—sink (procure locally)
—	1	1	717355	STRAINER—shower (incl. grid)
—	1	1	* 715497	HANDLE—pull, bath door
—	AR	AR	716805	MOULDING—bulkhead to wall (25' roll, CTL)
—	AR	AR	715544	SEAL ASSY.—bath door (25' roll, CTL) (ref. only) (incl. next (2) items)
—	—	2	* 791916	SEAL—door (extruded vinyl) (eff. w/1975) (69.12")
—	—	2	* 790869	RETAINER—door (aluminum) (eff. w/1975)
—	—	1	* 791242	MOULDING—drip bath door
—	1	1	* 715539	MOULDING—bath door, frame upper
—	1	1	* 715540	MOULDING—bath door, frame lower
—	2	2	—	MIRROR—medicine cabinet (procure locally)
—	1	1	—	STOP—bath module door (procure locally)
—	—	1	* 791683	CABINET—medicine (eff. w/1975)
—	1	1	718816	CURTAIN—shower (white) above bath door
—	—	2	791756	CURTAIN—shower (gold) (w/RPO 681, 697)
—	—	2	NPN	CURTAIN—shower (w/RPO 641) (ref. 2010793) (procure locally)
—	—	2	2000327	CURTAIN—shower (w/RPO 698)
—	—	2	2027434	CURTAIN—shower (w/RPO 685)
—	—	1	NPN	CURTAIN—shower (w/RPO 683) (ref. 2006775) (procure locally)
—	—	1	* 794995	TRACK—shower curtain, (above bath door) (repl. 717858)
—	AR	AR	* 715498	SLIDE—shower curtain
—	2	2	* 715473	END—shower curtain, above bath door
—	8	8	* 717857	RIVET—shower curtain, above bath door
—	—	1	* 790357	INSERT ASSY.—incomplete bath module (fiberglass construction) (w/ZEO6081 & ZEO6581 only)
—	—	1	* 2030659	INSERT ASSY.—incomplete bath module (fiberglass construction) (w/2030660 bath module only)
—	—	2	792166	BRACKET—bath module to roof support
—	—	3	—	BUMPER—door and drawer (procure locally)
—	—	1	* 790342	RING ASSY.—towel holder
—	—	1	* 790340	BAR ASSY.—towel
—	—	1	790341	HOLDER ASSY.—tissue
—	—	1	—	INSULATION—shower drain trap (procure locally) (ref. 2003560)
—	—	5	—	SCREW—drip moulding to door (8—18 x 1/2") (procure locally) (ref. 9425795)
—	—	2	NPN	BRACKET—bath module to roof support (ref. 2000552) (make locally)
—	—	2	2000001	BRACKET—bath/shower module to roof (w/ZEO6582, ZEO6584)
—	—	1	2007608	CABINET—vanity, bath module (w/ZEO6582, ZEO6584)
—	—	1	2006750	BRACKET—base, corner bath (w/ZEO6582)
—	AR	AR	2013358	BOARD—particle, service (.50 x 48.0 x 96.0") (rosewood grain)
—	AR	AR	2013359	BOARD—particle, service (.50 x 48.0 x 96.0") (walnut grain)

NOTES

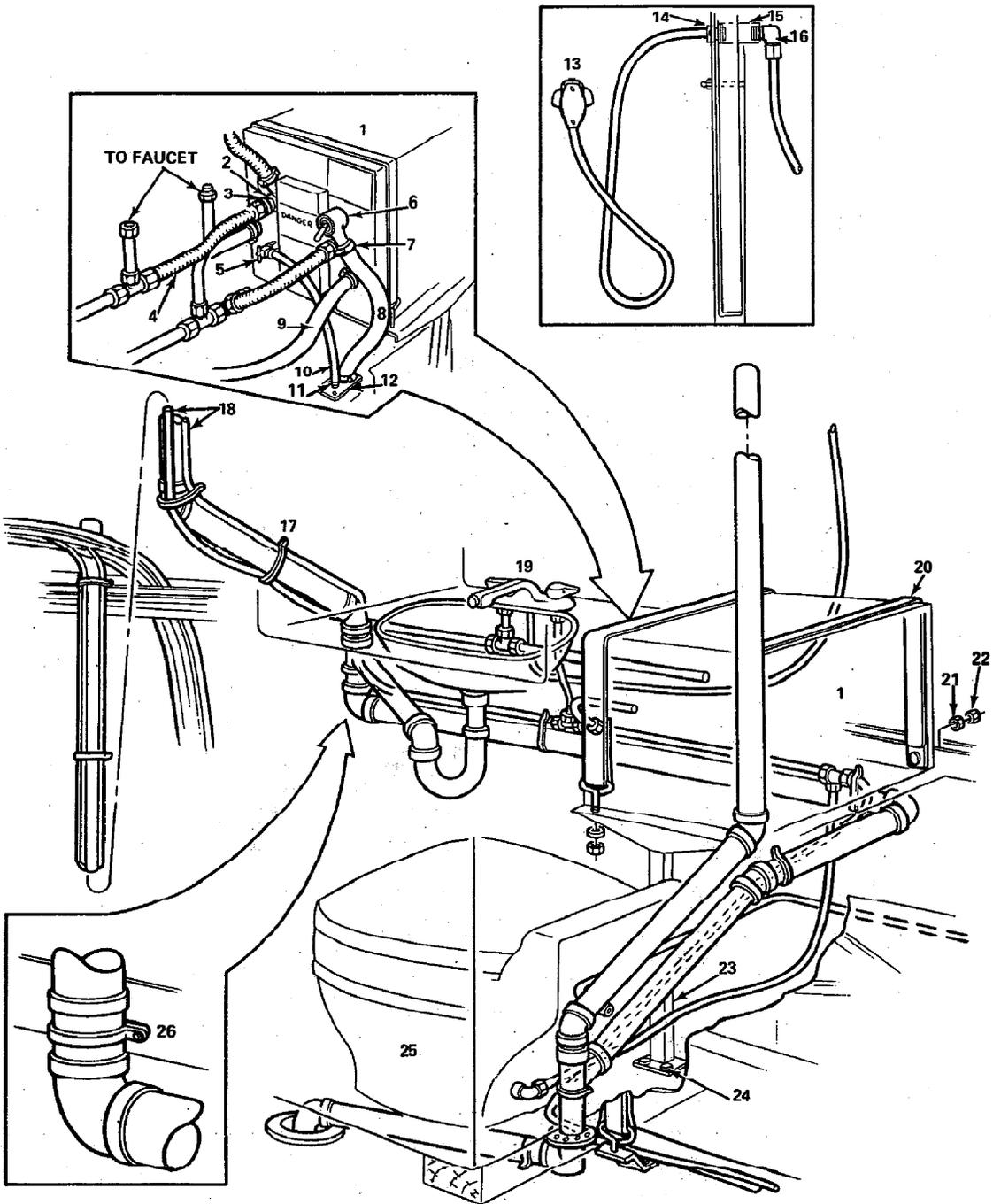

28P-5002

28.172D PLUMBING — BATHROOM MODULE

FURNISHINGS

KEY 230 260 PART NUMBER

28.172D PLUMBING—BATHROOM MODULE

1	1	1	—	HEATER ASSY.—water (see group 28.034)
2	2	2	191032	NIPPLE—tank
3	2	2	455946	REDUCER
4	2	2	791190	PIPE ASSY.—outlet, hot water (copper) (prior to 1977)
5	1	1	—	VALVE—drain (.34 full thread) (procure locally) (ref. 148344)
6	1	1	2489388	NIPPLE
7	1	1	2468869	CLAMP—hot water tank
8	AR	AR	9433154	HOSE—overflow .500 special bulk (25' roll) (CTL)
9	AR	AR	8885560	HOSE—preheat. (50' roll) (CTL) (repl. 482434)
10	AR	AR	2224567	HOSE—drain (39" length) (CTL)
11	2	2	2468869	CLAMP—water drain (repl. 2494772)
12	1	1	790058	BULKHEAD ASSY.—water drain (prior to 1978)
12	1	1	2036598	BULKHEAD ASSY.—water drain (1978)
12	1	1	791238	GASKET—water drain
13	1	1	—	SHOWER ASSY.—(complete) (see group 28.060)
14	—	1	9427747	NIPPLE—check valve to shower hose (eff. w/ 1975)
14	—	1	2002696	SEAL—nipple to module
15	—	2	796778	VALVE ASSY.—shower supply tube (check) (eff. w/ 1975)
16	—	1	796779	ELBOW—check valve (1/2" NPT male 90") (eff. w/ 1975)
17	—	AR	1324714	CLIP—band (25' roll, CTL) (repl. 8877970)
18	—	1	790337	PIPE ASSY.—water (eff. w/ 1975) (w/out ZE06582)
18	—	1	2006650	PIPE ASSY.—water (w/ZE06582)
19	1	1	—	FAUCET ASSY.—bath sink (see group 28.062)
20	2	2	791080	STRAP ASSY.—tank (w/707465 tank)
21	2	2	9418304	WASHER—strap
22	2	2	9417954	NUT—strap
23	1	1	791082	SUPPORT ASSY.—(w/707465 tank)
23	1	1	2005633	SUPPORT ASSY.—(w/2005305 tank) (exc./ZE06582, ZE06584)
23	—	2	2009813	SUPPORT—hot water tank (V-shaped) (w/ZE06582, ZE06584)
24	1	1	3718496	WASHER—support screw
24	2	2	—	SCREW—support (Proc. Loc.) (ref. 9422176)
25	1	1	—	TOILET ASSY.—aqua magic (see gr. 28.068)
26	AR	AR	791156	CLIP—pipe
—	—	1	—	BRACKET—hoses to floor (make locally) (ref. 2005069)
—	1	1	8885553	SERVICE KIT—preheat hose (prior to 1975) (incl. next [7] items)
—	4	4	1470030	CLAMP—hose
—	2	2	2003222	HOSE
—	2	2	705144	GROMMET
—	2	2	9414723	SCREW
—	2	2	2317218	GROMMET
—	1	1	2003216	BRACKET
—	4	4	2003223	NIPPLE
—	—	1	8885554	SERVICE KIT—preheat hose (eff. w/ 1975) (includes next [7] items)
—	—	4	1470030	CLAMP—hose
—	—	2	2003222	HOSE
—	—	2	2003217	GROMMET
—	—	2	700368	RIVET—blind
—	—	4	2317218	GROMMET
—	—	1	2003216	BRACKET
—	—	4	2003223	NIPPLE
—	—	1	2020896	DRAIN ASSY.—shower (1978)
—	—	1	—	WASHER—shower drain (procure locally) (1978)
—	—	1	2020888	NUT—shower & sink drain flange (1978)
—	—	1	—	PIPE ASSY.—sanitary RH & LH (procure locally) (1978)
—	—	1	2020881	DRAIN ASSY.—bath sink (1978)
—	—	1	—	NUT—bath sink flange (procure locally) (ref. 2020890) (1978)
—	—	1	—	WASHER—bath sink nut (procure locally) (ref. 2020883) (1978)
—	—	1	—	PLUG ASSY.—bath sink drain (procure locally) (ref. 2020884) (1978)
—	—	1	2034457	SEAL—bath sink drain (1978)
—	—	1	790052	ADAPTER—bath sink drain to holding tank (1978)
—	—	1	3876138	O—RING—bath sink drain adapter seal (1978)
—	—	1	798356	TUBE ASSY.—bath sink faucet (1978)
—	—	1	2034647	TEE—bath sink faucet tube (1978)
—	—	1	2034656	TUBE ASSY.—bath sink to water pump (50.12" lg.) (1978)

FURNISHINGS

KEY 230 260 PART NUMBER

28.172D PLUMBING—BATHROOM MODULE (Cont.)

—	—	1	2034657	TUBE ASSY.—bath sink to water pump (52.50" lg.) (1978)
—	—	1	2034648	ADAPTER—bath faucet to water pump tube (1978)
—	—	1	2034674	ADAPTER—bath faucet to water pump tube (1978)
—	—	1	2034645	TEE—bath sink to water pump (1978)
—	—	1	—	COCK—drain bath faucet to water pump (procure locally) (1978)
—	—	1	8877861	SLEEVE—drain cock-ball (1978)
—	—	1	2034666	TUBE ASSY.—hot water cross over (1978)
—	—	1	2034651	TUBE ASSY.—hot water to bath sink faucet (1978)
—	—	1	2034663	TUBE ASSY.—bath sink to shower head (1978)
—	—	1	2034654	TUBE ASSY.—hot water tank (1978)
—	—	1	455946	REDUCER—hot water tank tube (1978)
—	—	1	2034670	ADAPTER—hot water tank cold water inlet (1978)
—	—	1	2034652	TUBE ASSY.—hot water tank fill (1978)
—	—	1	719639	NIPPLE—toilet drain (1978)
—	—	1	2020888	NIPPLE—toilet drain (1978)
—	—	1	2020899	FLANGE—toilet to bath module (1978)
—	—	1	2008139	COVER—shower drain trap (w/ZEO6582, ZEO6584)
—	—	1	2008138	COVER—shower drain trap (exc./ZEO6582, ZEO6584)
—	—	2	2008147	GROMMET — engine to hot water supply and return hose thru floor

FURNISHINGS

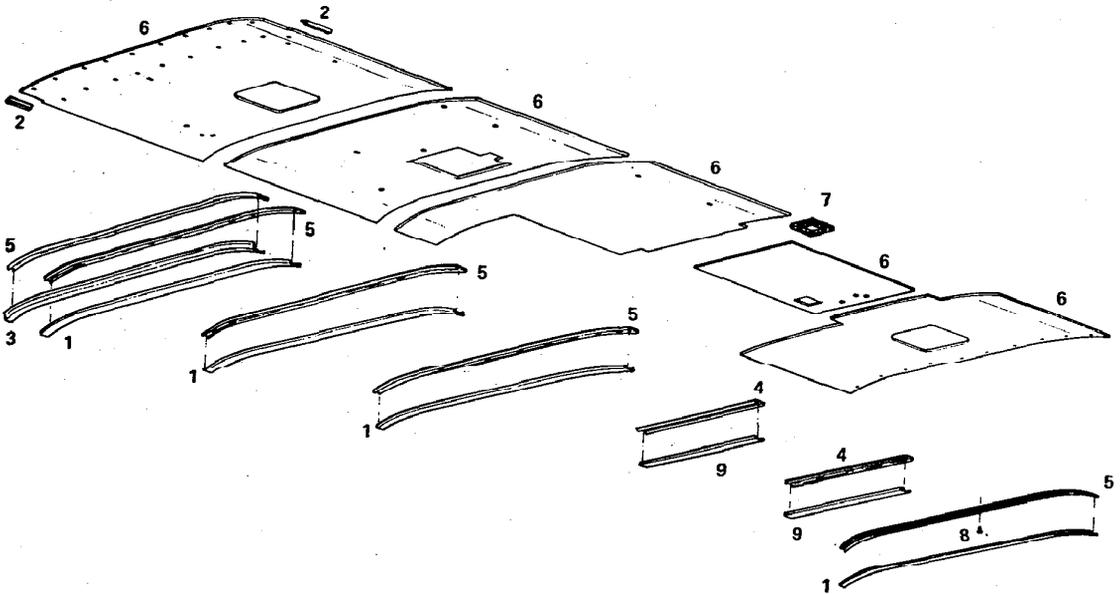

28P-34

KEY	230	260	PART NUMBER
-----	-----	-----	-------------

28.174 CEILING PANELS AND MOULDING (exc. /ZE06582, ZEO6584)

—	1	1	791829	MOULDING—front privacy/divider drape track (ref. 715543)
1	AR	AR	715542	MOULDING—ceiling, white (1" wide x 71.46" long)
2	—	2	791195	MOULDING—edge, front (eff. w/1975)
3	—	1	791829	MOULDING—ceiling, privacy curtain (plastic) (eff. w/1975)
4	—	AR	792173	RETAINER—ceiling and wall moulding, 5 slots, 34" long (eff. w/1975)
5	—	5	792172	RETAINER—ceiling panel moulding, 10 slots, 70" long (eff. w/1975)
—	AR	AR	—	PANEL—ceiling, white upson board (.165 thick) (173" x 137") (prior to 1975) (ref 718008) (procure locally)
—	AR	AR	—	PANEL—rear side, white upson board (.165 thick) (173" x 137") (prior to 1975) (ref. 718008) (procure locally)
—	1	1	718007	PANEL—ceiling, moulded fiberglass, hallway between bath and closet (prior to 1975)
—	—	1	2027968	PANEL—ceiling (72.75" x 50.90") (CTL) (1978)
6	—	1	8885551	PANEL—ceiling (72.75" x 50.90") (CTL) (eff. w/1975) (prior to 1978)
6	—	1	2027968	PANEL—ceiling, No. 1 (w/RPO 685) (eff. w/1977)
6	—	1	2027967	PANEL—ceiling, No. 2 (w/RPO 685) (eff. w/1977)
7	—	AR	—	ADHESIVE—foam insulation (procure locally) (ref. 8860955)
8	—	1	—	SCREW—retainer (8—18 x 3/8) (procure locally)
9	—	AR	693837	MOULDING—ceiling (68.80") (CTL)
—	—	10	716846	RIVET—retainer (eff. w/1975)

FURNISHINGS

KEY 230 260 PART NUMBER

28.174E CEILING PANELS AND MOULDING (w/ZEO6582, ZEO6584)

—	—	AR	8885578	PANEL—interior trim (service blank) (48" x 74" CTL)
—	—	1	2008351	MOULDING—edge, front panel
—	—	AR	8885564	MOULDING—headliner retainer (6" CTL) (between No. 1 panel and driver compartment panel, between No. 3 & 4 panels, and to the rear of panel No. 5) (w/out ZEO6584)
—	—	AR	NS	MOULDING—head liner retainer (12" CTL) (between No. 1 & 2 panel, between No. 2 & 3 panel, and between No. 4 & 5 panels) (exc./ZEO6584) (ref. 8885576)
—	—	AR	715542	MOULDING—headliner retainer (71.46" lg.) (w/ZEO6584)
—	—	AR	792172	RETAINER—roof trim moulding (70.00" lg.) (w/10-.188 x .562 oval slots) (w/ZEO6584)
—	—	4	2008215	INSERT—moulding, headliner (exc./ZEO6584)

28.176 PANELS—SIDE AND MOULDING

NOTE: " + " indicates not serviced, for reference only. See Group 28.180 for raw material coverings.

—	AR	AR	2004742	MOULDING—front to end cap (white) (roof rail trim) (3.66" x 10'8" CTL) (repl. 716806, 790872) (exc./ZEO6582)
—	—	AR	8885563	MOULDING—front to end cap (white) (roof rail trim) (3.66" x 12' CTL) (w/ZEO6582, ZEO6584)
—	—	60	3722217	CLIP—moulding, front to end cup (eff. w/Serial No. 6V100878)
—	AR	AR	715541	MOULDING—side upson board to end cap
—	—	2	792290	RETAINER—moulding, ceiling and wall, 3 slots, 9—5" long (eff. w/1975)
—	AR	AR	791837	MOULDING—entrance door (goes around door jam) (white) (86" CTL) (repl. 717026)
—	—	1	790059	MOULDING—entrance door carpet (eff. w/1975) (extruded aluminum) ("H")
—	—	2	2004720	MOULDING—upper to lower wall panel (1/4" division) (44.50") (extruded aluminum) ("H") (eff. w/1975) (repl. 792179)
—	—	1	2004721	MOULDING—upper to lower wall panel (1/4" division) (3.75") (eff. w/1975) (repl. 792178)
—	—	AR	792182	MOULDING—"H" lower wall (rosewood vinyl wrap) (w/RPO 683) (vehicles built prior to June 21, 1976)
—	—	AR	2001116	MOULDING—"H" lower wall (walnut) (w/RPO 697) (vehicles built after June 21, 1976)
—	AR	AR	723654	MOULDING—"H", paneling (teak) (w/RPO 692, 693, 695, 696)
—	AR	AR	723655	MOULDING—"H", paneling (birch) (w/RPO 690)
—	—	AR	2001116	MOULDING—"H", lower wall (walnut) (w/RPO 641, 698)
—	—	1	2007415	MOULDING—"H", upper to lower wall panel (103.38" CTL) (chrome like finish) (w/ZEO6582, ZEO6584)
—	—	1	2004719	MOULDING—"H", upper to lower wall panel (horizontal) (w/ZEO6582, ZEO6584)
—	—	1	2007973	MOULDING—"H", upper to lower wall panel (w/ZEO6584) (92.18" CTL)
—	—	1	2007416	MOULDING—"H", upper to lower wall (w/ZEO6584) (64.46" CTL)
—	—	1	2010334	PANEL—settee, lower LH trim (w/RPO 641)
—	—	1	794548	PANEL—settee, lower LH trim (w/RPO 681)
—	—	1	2027550	PANEL—settee, lower LH trim (w/RPO 685)
—	—	1	792154	PANEL—settee, lower LH trim (w/RPO 697)
—	—	1	2000657	PANEL—settee, lower LH trim (w/RPO 698)
—	—	1	2010335	PANEL—settee, lower RH trim (w/RPO 641)
—	—	1	2000658	PANEL—settee, lower RH trim (w/RPO 698)
—	—	1	792153	PANEL—settee, lower RH trim (w/RPO 697)
—	—	1	794551	PANEL—settee, lower RH trim (w/RPO 681)
—	—	1	2027551	PANEL—settee lower RH trim (w/RPO 685)
—	—	1	2010343	PANEL ASSY.—dinetto side trim (fabric covered) (w/RPO 641)
—	—	1	790322	PANEL ASSY.—dinetto side trim (fabric covered) (w/RPO 697)
—	—	1	794541	PANEL ASSY.—dinetto side trim (fabric covered) (w/RPO 681)
—	—	1	2000653	PANEL ASSY.—dinetto side trim (fabric covered) (w/RPO 698)
—	—	1	2010343	PANEL ASSY.—dinetto side trim (fabric covered) (w/RPO 641)
—	—	1	2010332	PANEL ASSY.—rear trim (below center window) (w/RPO 641)
—	—	1	790307	PANEL ASSY.—rear trim (below center window) (w/RPO 697)
—	—	1	794546	PANEL ASSY.—rear trim (below center window) (w/RPO 681)

28.176 PANELS—SIDE AND MOULDING (Cont.)

—	—	1	2027553	PANEL ASSY.—rear trim (below center window) (w/RPO 685)	
—	—	1	2000655	PANEL ASSY.—rear trim (below center window) (w/RPO 698)	
—	—	1	2010333	PANEL — rear trim lower center (floor to trim cushion) (w/RPO 641)	
—	—	1	2013216	PANEL ASSY. — trim, love seat (w/RPO 641)	
—	—	1	2024086	PANEL ASSY.—trim, love seat (w/RPO 683)	
—	—	1	2013210	PANEL ASSY. — trim, love seat (w/RPO 697)	
—	—	1	2013213	PANEL ASSY. — trim, love seat (w/RPO 698)	
—	—	1	794550	PANEL—rear trim, lower center (floor to trim cushion) (w/RPO 681)	
—	—	1	2027552	PANEL—rear trim, lower center (floor to trim cushion) (w/RPO 685)	
—	—	1	2000656	PANEL—rear trim, lower center (floor to trim cushion) (w/RPO 698)	
—	—	1	792152	PANEL—rear trim, lower center (floor to trim cushion) (w/RPO 697)	
—	1	1	715583	PANEL—accent, rear interior trim (w/RPO 690)	
—	1	1	715584	PANEL—accent, rear interior trim (w/RPO 692)	
—	1	1	715586	PANEL—accent, rear interior trim (w/RPO 693)	
—	1	1	715588	PANEL—accent, rear interior trim (w/RPO 695)	
—	—	1	2004718	MOULDING—LH, upper to lower wall panel (141.50" x 1.25") (extruded aluminum) (repl. 792180)	
—	—	1	2004719	MOULDING—upper to lower wall panel (74.25" long) (extruded aluminum section) (repl. 792181)	
—	AR	AR	8885551	PANEL — interior upper trim (bottom of window line up) (72.75" x 50.90", CTL) (Service blank) (exc./ZE06582,ZE06584)	
—	AR	AR	8885578	PANEL — interior upper trim (bottom of window line up) (48" x 74", CTL) (Service blank) (w/ZE06582,ZE06584)	
—	AR	AR	8885580	PANEL — interior lower trim (bottom of window line down) (also used on entrance door) 48" x 48", CTL) (service blank) (rosewood) (w/RPO 681, 683, 697) (vehicles built prior to June 21, 1976)	
—	—	AR	8885579	PANEL—interior lower trim (bottom of window line down) (also used on entrance door) (48" x 48", CTL) (service blank) (walnut) (w/RPO 641, 697, 698) (vehicles built after June 21, 1976)	
—	—	1	2007946	PANEL—side, upper (galley) (42.90 x 38.32) (repl. 791760)	
—	—	1	2007940	PANEL—side, upper (galley) (12.06 x 3.42) (exc./ZE06582,ZE06584) (repl. 791811)	
—	AR	AR	2007941	PANEL—side upper (galley window) (12.06" x 2.00") (repl. 791812)	
—	1	1	+	717680	PANEL—front entrance door (w/RPO 690) (Procure locally)
—	1	1	+	717681	PANEL—front entrance door (w/RPO 692, 693, 695, 696)(Procure locally)
—	AR	AR	+	723652	PANEL—side, teak (4' x 8') (w/RPO 692, 693, 695, 696)
—	AR	AR	+	723653	PANEL—side, birch (4' x 8') (w/RPO 690)

28.180 WOOD AND CUSHION COVERING

—	1	1	8885498	TEXTOLITE—wood covering (gold) (30" x 60" x .051" thick)
—	1	1	8885499	TEXTOLITE—wood covering (green) (30" x 60" x .051" thick)
—	1	1	8885501	TEXTOLITE—wood covering (teak) (3' x 10' x .062" thick) (repl. 8885500)
—	1	1	8885503	TEXTOLITE—wood covering (white) (4' x 8' x .062" thick) (repl. 8885502)
—	1	1	8885505	TEXTOLITE—wood covering (light blue) (30" x 60" x .051" thick)
—	1	1	8885513	VINYL—wood covering (teak) (3 yd. x 48")
—	1	1	8885515	VINYL—wood covering (black) (3 yd. x 55")
—	1	1	—	VINYL—wood covering (white) (3 yd. x 56") (procure locally) (ref. 8885516) (used for overhead cabinet end pads)
—	1	1	8885517	VINYL—wood covering (gold) (3 yd. x 55")
—	1	1	8885519	VINYL—wood covering (light blue) (3 yd. x 55")
—	1	1	NS	FABRIC—cushion cover (yellow/solid) (54" x 3 yd.) (ref. 8885487)
—	1	1	8885488	FABRIC—cushion cover (orange/solid) (54" x 3 yd.)
—	1	1	8885489	FABRIC—cushion cover (green/floral) (54" x 3 yd.)
—	1	1	8885490	FABRIC—cushion cover (gold/floral) (54" x 3 yd.)
—	1	1	8885491	FABRIC—cushion cover (blue/solid) (54" x 3 yd.)
—	1	1	8885492	FABRIC—cushion cover (blue/floral) (54" x 3 yd.)
—	1	1	8885493	FABRIC—cushion cover (gold/solid) (54" x 3 yd.)
—	1	1	NS	FABRIC—cushion cover (yellow/solid vinyl) (54" x 3 yd.) (ref. 8885494)
—	AR	AR	2037497	FABRIC—cushion (saffron) (54" x 3 yd.) (w/RPO 641)
—	—	AR	8885557	FABRIC—cushion (dundee gold, plaid) (54" x 3 yd.) (w/RPO 681)
—	—	AR	8885596	FABRIC—cushion (dundee gold, solid) (54" x 3 yd.) (w/RPO 681)
—	1	1	8885497	FABRIC—cushion cover (crushed velvet) (54" x 3 yd.) (w/RPO 696)
—	—	AR	8885545	FABRIC—cushion (sandstone brahmin) (54" x 3 yd.) (w/RPO 697)

FURNISHINGS

KEY 230 260 PART NUMBER

28.180 WOOD AND CUSHION COVERING (Cont.)

—	—	AR	8885558	FABRIC—cushion (green plaid) (54" x 3 yd.) (w/RPO 698)
—	—	AR	8885559	FABRIC—cushion (lime green plain) (54" x 3 yd.) (w/RPO 698)
—	AR	AR	2032695	FABRIC—cushion (stripe) (54" x 3 yd.) (transmode)
—	AR	AR	2032696	FABRIC—cushion (orange) (54" x 3 yd.) (transmode)
—	AR	AR	2032697	FABRIC—cushion (buckskin) (54" x 3 yd.) (transmode)