

**X-7425**

# **1973 GMC Motorhome Maintenance Manual**

## **Table of Contents**

Section	Description
0	Information, Periodic Maintenance and Lubrication
1	Body, Heating and Air Conditioning
2	Frame
3A	Front Suspension
3B	Drive Axles
3C	Final Drive
4	Rear Suspension
5	Brakes
6A	Engine
6K	Engine Cooling
6M	Engine Fuel System
6T	Emission Control Systems
6Y	Engine Electrical
7	Transmission
8	Fuel Tank and Exhaust
9	Steering System
10	Wheels and Tires
12	Chassis Electrical
13	Radiator and Coolant Recovery System
14	Bumpers
24	Miscellaneous Living Area Facilities
24A	Periodic Maintenance and Lubrication
24B	Living Area Electrical System
24C	Motor Generator
24D	Refrigerator
24E	Roof Mounted Air Conditioner (Information not available at time of publication)
24F	LP Gas System
24G	Furnace
24H	Range/Oven
24J	Living Area Water System
24K	Toilet
24L	Holding Tank and Drainage System
24M	Thermasan System
24N	Cabinets and Furniture
24P	Exhaust Vents
24Q	Other Equipment (Vacuum Cleaner)
	Wiring Diagrams



# SECTION 0 GENERAL INFORMATION, PERIODIC MAINTENANCE, AND LUBRICATION

Contents Of This Section Are Listed Below:

SUBJECT	PAGE NO.
Vehicle Identification .....	0-1
Component Identification .....	0-2
Hoisting Instructions.....	0-2
Jack Usage Instructions .....	0-3
Towing Motor Home .....	0-4
Engine, Chassis, and Body Maintenance Schedule .....	0-6
Explanation of Maintenance Schedule .....	0-7
Recommended Fluids and Lubricants .....	0-10
Lubrication Details.....	0-11
Winterization and Vehicle Storage .....	0-15

## VEHICLE IDENTIFICATION

The Vehicle Identification and Weight Rating Plate (figure 1) located behind the right front access door shows the "Vehicle Identification Number", and the "As Manufactured" Gross Vehicle Weight Rating for the Motor Home to which it is attached.

In order that the vehicle may be specifically identified as to manufacturer, engine type, year of manufacture, etc., refer to Figure 2.

**GENERAL MOTORS CORPORATION**

WARRANTY MAY BE VOIDED IF WEIGHT EXCEEDS ANY OF THE RATINGS SHOWN.

GROSS VEHICLE WEIGHT INCLUDES WEIGHT OF BASE VEHICLE, ALL ADDED EQUIPMENT, DRIVER AND PASSENGERS, AND ALL PROPERTY LOADED INTO OR ONTO VEHICLE.

RATINGS IN POUNDS	
AS MANUFACTURED	
GROSS VEHICLE WEIGHT FOR THIS VEHICLE	<input style="width: 50px;" type="text"/>
MAXIMUM FRONT END WEIGHT AT GROUND	<input style="width: 50px;" type="text"/>
MAXIMUM REAR END WEIGHT AT GROUND	<input style="width: 50px;" type="text"/>
VEHICLE IDENT. NO.	<input style="width: 150px;" type="text"/>

A-2329

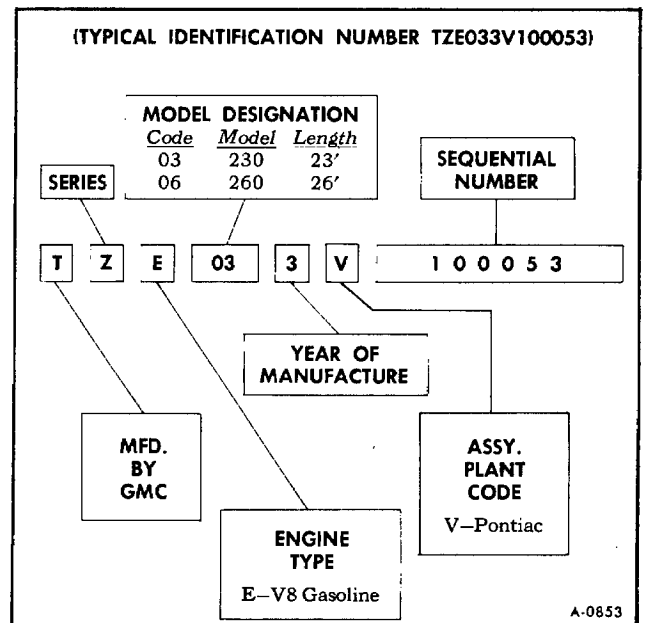

Figure 1-Vehicle Identification Plate

Figure 2-Vehicle Identification Number

## COMPONENT IDENTIFICATION

### ENGINE

Motor Home engines are identified by a code tape installed directly above the engine serial number which is stamped on the engine oil fill tube (figure 3).

### TRANSMISSION

The transmission model and code numbers are stamped on the converter housing as shown in Figure 4.

### FINAL DRIVE

The ratio and date codes are stamped on the flange near the right hand spreader hole as shown in Figure 5.

**Date Code:** The code letter is for the month and the number(s) are for actual date.

**Ratio Code:** "T" = 3.07:1    **EXAMPLE:** T A12 = 3.07:1, built January 12 (J = 9th month, I is not used).

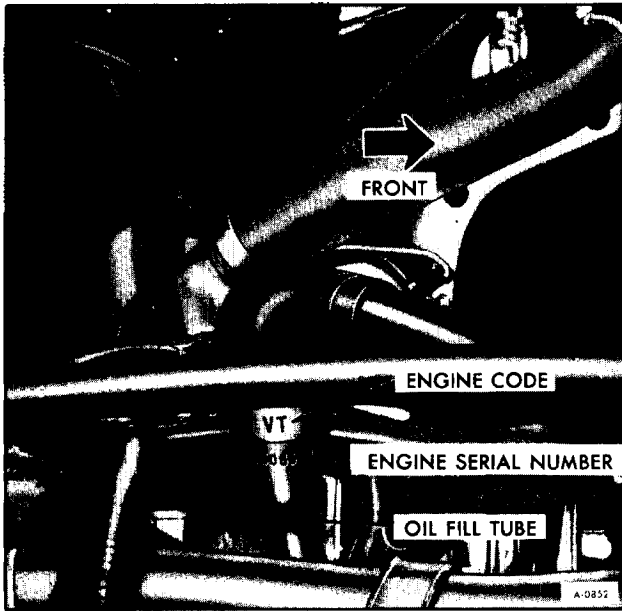

Figure 3-Engine Identification

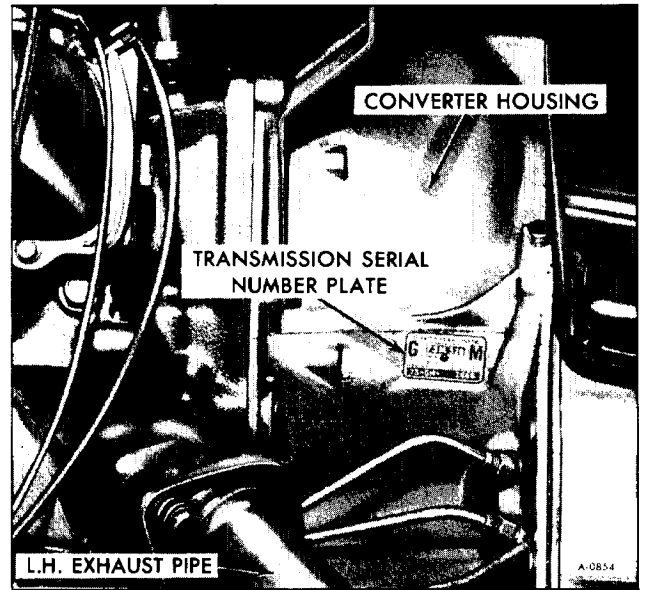

Figure 4-Transmission Serial Number Plate

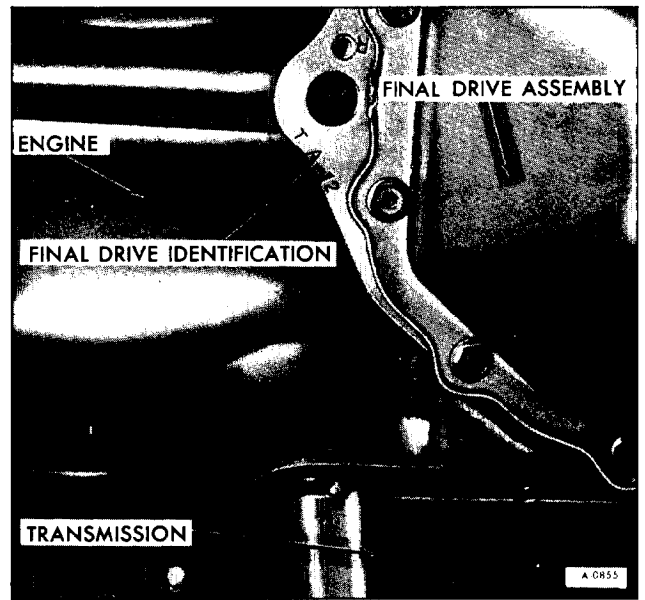

Figure 5-Final Drive Identification

## HOISTING INSTRUCTIONS

A twin post hoist of sufficient capacity and with proper adapters and/or fittings must be used.

Front hoisting position is the front engine cross-member.

Rear hoisting must be done at the rear suspension brackets. If an "I" beam type adapter is used it should be approximately 82 inches in length to gain adequate support at suspension brackets. (figure 6)

If vehicle is to be placed on jack stands for maintenance or repairs, the hoisting points should be used.

**CAUTION:** To help avoid serious damage to your Motor Home, the vehicle should be raised only on twin post hoists of 15,000 pounds or more total rated capacity, at the suspension points noted (see diagram). Before raising, check overhead clearance to see that it is sufficient for the Motor Home. Do NOT use the vehicle jack for hoisting or maintenance. It is designed for use only when changing tires.

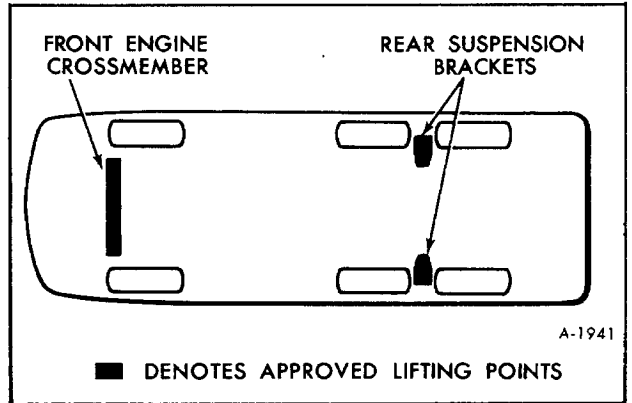

Figure 6—Motor Home Hoisting Points

## JACK USAGE INSTRUCTIONS

### CAUTIONS

1. Follow jacking instructions in order to reduce the possibility of serious personal injury.
2. The jack is designed for use only when changing wheels.
3. Never get beneath the vehicle when using jack.
4. Do not start or run engine while vehicle is on jack.

### INSTRUCTIONS

- Park on level surface and set parking brake firmly.
- Set transmission in "PARK".
- Activate Hazard Warning Flasher.
- Jack, jack chain, handle, "jacking pad" (wooden block), and lug wrench are located under dinette seat.
- Block both front and rear of the wheel diagonally opposite the jack position.
- Loosen but do not remove wheel nuts.
- **JACKING AT FRONT**—Place hydraulic jack on wood block near energy absorbing front bumper bracket. Place hook at flange of front cross-member. Pass chain under bumper and adjust chain length to snug fit on fork on top of jack (See figure 7).

- **JACKING AT REAR**—Place hydraulic jack on wood block close to rear suspension bracket (See figure 8). The hook is placed in the drainage slot under bracket. Adjust chain length so link will fit in fork at top of jack.
- Close valve at base of jack and insert jack handle.

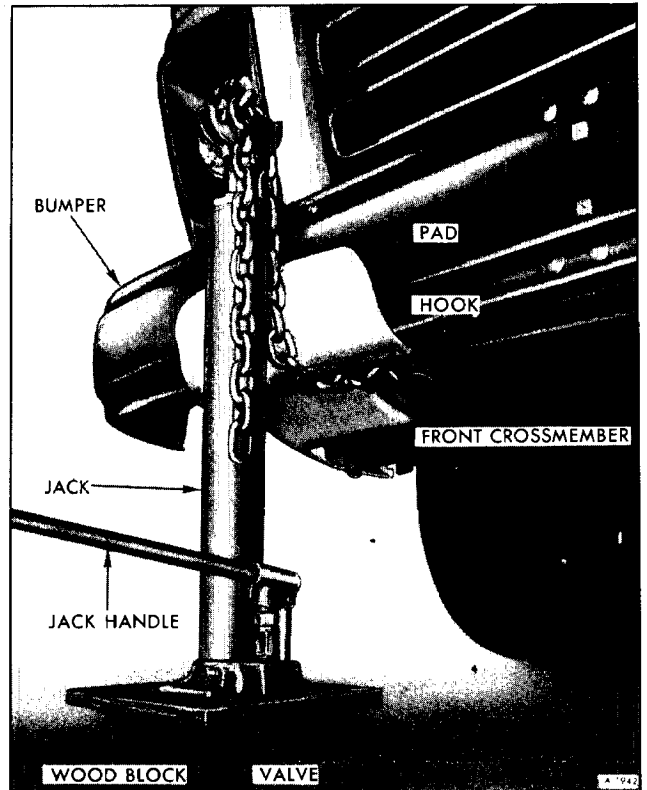

Figure 7—Jacking at Front of Motor Home

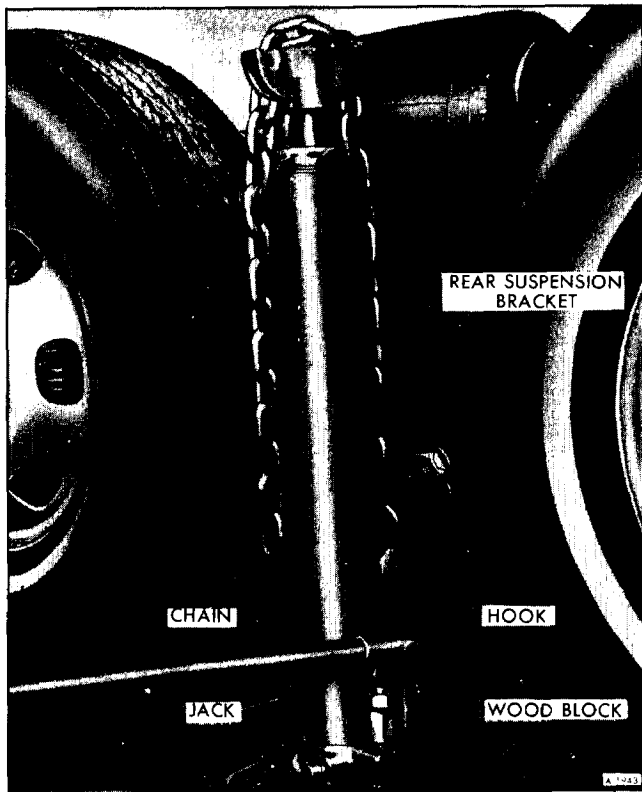

Figure 8—Jacking at Rear of Motor Home

- Always operate jack with slow, smooth motion.
- Raise vehicle so tire just clears surface, replace wheel and slightly tighten wheel nuts.
- Open valve at base of jack to lower, then fully tighten wheel nuts. Proper torque is 250 foot pounds.

**CAUTION:** Use lug wrench provided to tighten wheel nuts securely if torque wrench is not available. (Follow the nut tightening sequence shown in *WHEELS AND TIRES*, Section 10 of this manual. At the earliest opportunity have wheel nut torque checked. This is necessary to help prevent loosening or stripping of the wheel nuts.

## TOWING MOTOR HOME

Proper lifting or towing equipment is necessary to prevent damage to the GMC Motor Home during any towing operation. State (Provincial in Canada) and local laws applicable to vehicles in tow must also be followed. The Motor Home may be towed on all six wheels at speeds of less than 35 MPH, for distances up to 50 miles, provided final drive, axle, and transmission are otherwise normally operable. For such towing, parking brake must be released, transmission must be in neutral, and the ignition key turned to OFF position.

## TOWING AT FRONT (FIGURE 9)

**NOTE:** Attachments must be to frame front crossmember of the Motor Home, not to bumpers or bracketing. Separate safety chains or cables should be used. Care must be taken in installation of chains to ensure that they do not cause damage. Remember that power brake and steering assists will not be available when engine is inoperative.

Certain other precautions are required when it is necessary to tow with the front drive wheels lifted off the road. On Motor Homes equipped with the Power Level System, turn the valve dials, below the instrument panel, to "HOLD" position, thereby making the automatic height valves inoperative on the rear suspension. On Motor Homes not equipped with the optional Power Level System it will be necessary to disconnect the height control valve link arm at the rear suspension control arm (adjacent to the shock absorber stud) on each side of the vehicle (figure 10). Raising front of vehicle so front wheels are four inches off the ground will provide about five-inch ground clearance at the rear when towing.

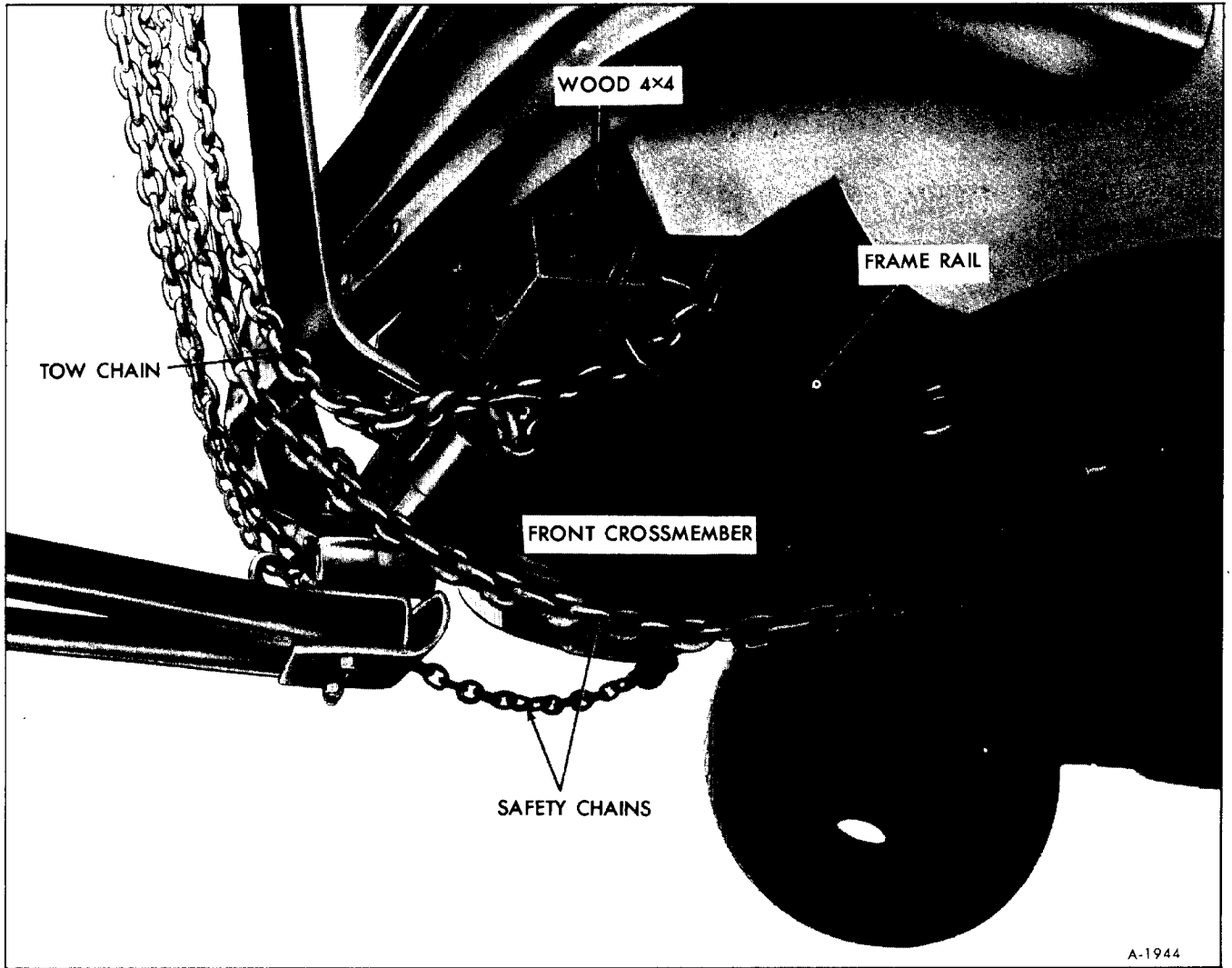

A-1944

Figure 9—Typical Towing Hook-up

## TOWING AT REAR

It is not recommended that vehicle be towed with the rear raised as this could result in suspension or crossmember damage.

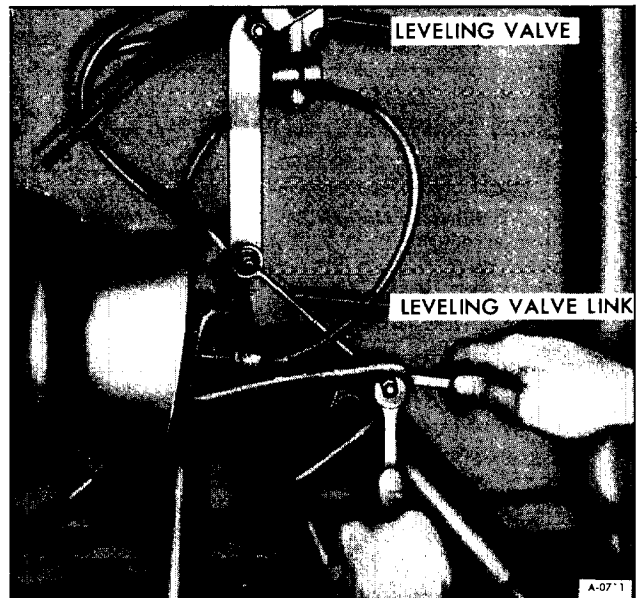

A-071

Figure 10—Disconnecting Leveling Valve Link Arm

# ENGINE, CHASSIS, AND BODY MAINTENANCE SCHEDULE

## LUBE AND GENERAL MAINTENANCE

WHEN TO PERFORM SERVICES (Months or Miles, Whichever Occurs First)	Item No.	SERVICES (For Details, See Numbered Paragraphs)
Every 3 months or 3,000 miles	1	Chassis Lubrication
	2	Engine Oil
Every 6 months or 6,000 miles	3	Fluid Levels
	4	Air Conditioning System
	5	Air Compressor Air Filter
Every 6,000 miles (Check wheel nut torque after 1st 500 miles)	6	Wheel and Tires
At 1st oil change and then every 2nd	7	Engine Oil Filter
Every 12 months or 12,000 miles	8	Automatic Transmission and Final Drive
	9	Cooling System
Every 24,000 miles	10	Rear Wheel Bearings
	11	Final Drive Boots & Output Shaft Seals

## SAFETY MAINTENANCE

Every 6 months or 6,000 miles	12	Brakes and Power Steering
	13	Exhaust System
	14	Drive Belts
	15	Suspension and Steering
	16	Owner Safety Checks
Every 6,000 miles	17	Disc Brakes
Every 12 months or 12,000 miles <sup>1</sup>	18	Drum Brakes and Parking Brake
	19	Throttle Linkage
	20	Headlights
	21	Underbody
	22	Bumpers

## EMISSION CONTROL MAINTENANCE

At 1st 6 months or 6,000 miles – then at 12 months/12,000 mile intervals	23	Thermostatically Controlled Air Cleaner
	24	Carburetor Choke
	25	Timing, Dwell, Carb. Idle, Distributor & Coil
At 1st 6 months or 6,000 miles	26	Carburetor & Intake Manifold Mounting
Every 6,000 miles	27	Spark Plugs (When using leaded fuels)
Every 12 months or 12,000 miles	28	Thermal Vacuum Switch and Hoses
	29	Carburetor Fuel Filter
	30	PCV System
	31	Air Cleaner Element
	32	Spark Plugs and Ignition Coil Wires
Every 24 months or 24,000 miles	33	Engine Compression
	34	ECS System
	35	Fuel Cap. Tanks and Lines

# EXPLANATION OF MAINTENANCE SCHEDULE

Presented below is a brief explanation of each of the services listed in the preceding Maintenance Schedule.

Vehicle operation under conditions such as heavy dust, continuous short trips, use of other than unleaded or low lead fuels or pulling trailers, is not considered normal use and therefore more frequent maintenance will be required. Such additional maintenance requirements are included where applicable.

## LUBE AND GENERAL MAINTENANCE

### ITEM

### NO. SERVICES

**1 CHASSIS**—Lubricate all grease fittings in front and rear suspension and steering linkage. Also lubricate transmission shift linkage, brake pedal spring, parking brake cable guides and linkage.

**2 ENGINE OIL**—Change each 3 months or 3,000 miles, whichever occurs first.

**3 FLUID LEVELS**—Check level of fluid in brake master cylinder, power steering pump, all batteries, engine, final drive, transmission, and windshield washer. The engine coolant should be checked for proper level and freeze protection to at least -35°F., or to the lowest temperature expected during the period of vehicle operation. Proper engine coolant also provides corrosion protection.

Any significant fluid loss in any of these systems or units could mean that a malfunction is developing and corrective action should be taken immediately. A low fluid level in the brake master cylinder front reservoir could also be an indicator that the disc brake pads need replacing.

**4 AIR CONDITIONING**—Check condition of air conditioning system hoses and refrigerant charge at sight glass. Replace hoses and/or refrigerant if need is indicated.

**5 AIR COMPRESSOR**—Filter should be washed with soap and water solution or replaced.

**6 WHEELS AND TIRES**—Have wheel-nut torque checked after 1st 500 miles and 500 miles after every wheel replacement thereafter. Check tires for excessive wear, nails, glass, cuts or other damage. Make certain wheels are not bent or cracked. Uneven or abnormal tire wear may indicate the need for alignment service. Tire inflation should be checked

monthly or more often if visual inspection indicates a need and after each tire rotation. Adjust pressure if required, as shown on tire placard on glove box door.

**7 ENGINE OIL FILTER**—Replace at the first oil change and every 2nd oil change thereafter.

**8 AUTOMATIC TRANSMISSION FLUID AND FINAL DRIVE LUBRICANT**—Change the transmission fluid and filter; change final drive lubricant.

**9 COOLING SYSTEM**—At 12-month or 12,000-mile intervals, wash radiator cap and filler neck with clean water, pressure test system and radiator cap for proper pressure holding capacity. (Tighten hose clamps and inspect condition of all cooling and heater hoses.) Replace hoses every 24 months or 24,000 miles or earlier if checked, swollen or otherwise deteriorated.

Also each 12 months or 12,000 miles, clean exterior of radiator core and air conditioning condenser. Every 24 months or 24,000 miles, drain, flush, and refill the cooling system with a new coolant solution.

**10 WHEEL BEARINGS**—Clean and repack rear wheel bearings with a lubricant as specified in the "Recommended Fluids and Lubricants" chart.

**11 FINAL DRIVE AXLE BOOTS AND OUTPUT SHAFT SEALS**—Check for damaged, torn or leaking boots on drive axles and for leaking output shaft seal. Replace defective parts as necessary.

## SAFETY MAINTENANCE

**12 BRAKES AND POWER STEERING**—Check lines and hoses for proper attachment, leaks, cracks, chafing, deterioration, etc. Any questionable parts noted should be replaced or repaired immediately. When abrasion or wear is evident on lines or hoses, the cause must be corrected.

**13 EXHAUST SYSTEM**—Check complete exhaust system and nearby body areas of vehicle engine and motor-generator system for broken, damaged, missing or mispositioned parts, open seams, holes, loose connections or other deterioration which could permit exhaust fumes to seep into the passenger compartment. Dust or water in the passenger compartment may be an indication of a problem in one of these areas. Any defects should be corrected immediately. To help ensure continued integrity, exhaust system pipes rearward of the muffler must be replaced whenever a new muffler is installed.



**14 ENGINE DRIVE BELTS**—Check belts driving fan, Delcotron, power steering pump and air conditioning compressor for cracks, fraying, wear and tension. Adjust or replace as necessary.

It is recommended that belts be replaced every 24 months or 24,000 miles, whichever occurs first.

**15 SUSPENSION AND STEERING**—Check for damaged, loose or missing parts, or parts showing visible signs of excessive wear or lack of lubrication in front and rear suspension and steering system.

**16 SAFETY CHECKS TO BE PERFORMED BY OWNER**—The maintenance schedule in the Operating Manual lists several items the owner should check and have repaired if not functioning properly.

**17 DISC BRAKES**—Check brake pads and condition of rotors while wheels are removed during tire rotation.

**18 DRUM BRAKES AND PARKING BRAKE**—Check drum brake linings and other internal brake components at rear wheels (drums, wheel cylinders, etc.). Parking brake adjustment also should be checked for drag and lubricated at every chassis lube period.

**NOTE:** More frequent checks should be made if driving conditions and habits result in frequent brake application.

**19 THROTTLE LINKAGE**—Check for damaged or missing parts, interference or binding.

**20 HEADLIGHTS**—Check for proper aim. Correct as necessary.

**21 UNDERBODY**—In geographic areas using a heavy concentration of road salt or other corrosive materials for snow removal or road dust control, flush and inspect the complete underside of the vehicle at least once each year, preferably after a winter's exposure. Particular attention should be given to cleaning out underbody members where dirt and other foreign materials may have collected.

**22 BUMPERS**—Check the front and rear bumper systems at 12-month/12,000-mile intervals to be sure the impact protection and clearance originally designed into the system remains in a state of full readiness. It also should be checked whenever there is obvious bumper misalignment, or whenever the vehicle has been involved in a significant collision in which the bumper was struck, even when no damage to the bumper system can be seen.

## EMISSION CONTROL MAINTENANCE

**23 THERMOSTATICALLY CONTROLLED AIR CLEANER**—Inspect installation to make certain that all hoses and ducts are connected and correctly installed. Also check valve for proper operation.

**24 CARBURETOR CHOKE**—Check choke mechanism for free operation. Any binding condition which may have developed due to petroleum gum formation on the choke shaft or from damage should be corrected.

**25 TIMING, DWELL, CARBURETOR IDLE, DISTRIBUTOR AND COIL**—Adjust ignition timing, dwell and carburetor idle speed accurately (following the specifications shown on the label attached to engine rocker cover) at the first 6 months or 6,000 miles of operation then at 12 month or 12,000 miles. Then at 12 month or 12,000 mile intervals. Adjustment must be made with test equipment known to be accurate.

Replace distributor points every 12 months or 12,000 miles and replace cam lubricator every 24 months or 24,000 miles. In addition, carefully inspect the interior and exterior of the distributor cap, distributor rotor and coil for cracks, carbon tracking, and terminal corrosion. Clean or replace as necessary at 24-month/24,000 mile intervals to prevent misfiring and/or deterioration.

Proper functioning of the carburetor is particularly essential to control of emissions. Correct mixtures for emission compliance and idle quality have been preset by GMC Truck. Plastic idle mixture limiters have been installed on the idle mixture screws to discourage unauthorized adjustment. These idle limiters are not to be removed unless some major carburetor repair or replacement which affects the idle screw adjustment has been necessary.

At 12 months or 12,000 mile intervals or in case of major carburetor overhaul, or when poor idle quality exists, the idle mixture should be adjusted by use of a CO meter when an accurate meter is available, or the alternate mechanical method should be used to adjust idle mixture (See SECTION 6M).

**26 CARBURETOR AND INTAKE MANIFOLD MOUNTING**—Torque carburetor and intake manifold attaching bolts and/or nuts at first 6 months or 6,000 miles of vehicle operation.

**27 SPARK PLUGS**—Replace at 6,000 mile intervals when operating with leaded fuels, or at 12,000-mile intervals when using unleaded fuels. Use of leaded fuels results in lead deposits on spark plugs and can cause misfiring at mileages less than 12,000 miles. Where misfiring occurs prior to 6,000 miles, spark plugs in good condition can often be cleaned, tested, and reinstalled in an engine with acceptable results.

**28 THERMAL VACUUM SWITCH AND HOSES**—Check for proper operation. A malfunctioning switch must be replaced. Check hoses for proper connection, cracking, abrasion or deterioration and replace as necessary.

**29 CARBURETOR FUEL FILTER**—Replace filter at 12-month/12,000-mile intervals or more frequently if clogged.

**30 POSITIVE CRANKCASE VENTILATION SYSTEM (PCV)**—Check system for satisfactory operation at 12-month or 12,000-mile intervals using a tester, and clean filter. Replace the PCV valve at 24-month or 24,000-mile intervals and blow out PCV valve hose with compressed air. The PCV valve should be replaced at 12-month or 12,000-mile intervals when the vehicle is used in operations involving heavy dust, extensive idling, trailer pulling, and short trip use at freezing temperatures where engine does not become thoroughly warmed-up.

**31 AIR CLEANER ELEMENT**—Replace the engine air cleaner element under normal operating conditions every 12,000 miles. Operation of vehicle in dusty areas will necessitate more frequent element replacement.

**CAUTION:** *Do not operate the engine without the air cleaner unless temporary removal is necessary during repair or maintenance of the vehicle. When the air cleaner is removed backfiring can cause fire in the engine compartment.*

**32 SPARK PLUG IGNITION COIL WIRES**—Inspect spark plug and ignition coil wires for evidence of chipping or cracking of exterior insulation and tight fit in the distributor cap and at the spark plugs. Exterior of wires should be cleaned, any evidence of corrosion on ends removed and wire replaced if deteriorated.

**33 ENGINE COMPRESSION**—Test engine cranking compression. If a problem exists, have correction made. Minimum compression recorded in any one cylinder should not be less than 70% of the highest cylinder. For example, if the highest pressure in any one cylinder is 150 lbs., the lowest allowable pressure for any other cylinder would be 105 lbs. ( $150 \times 70\% = 105$ ).

**34 EVAPORATION CONTROL SYSTEM (ECS)**—Check all fuel and vapor lines and hoses for proper connections and correct routing as well as condition. Remove canister(s) and check for cracks or damage. Replace damaged or deteriorated parts as necessary. Replace filter in lower section of canister.

If vehicle is equipped with two canisters, filter is located in the lower canister only.

**35 FUEL CAP, FUEL LINES AND FUEL TANKS**—Inspect the fuel tank cap and lines for damage which could cause leakage. Inspect fuel cap for correct sealing ability and indications of physical damage. Replace any damaged or malfunctioning parts.

## RECOMMENDED FLUIDS AND LUBRICANTS

USAGE	FLUID/LUBRICANT	CAPACITIES
Engine oil	High quality SE oil	5 qts. (6 w/filter)
Power steering system and pump reservoir. Includes windshield wiper motor	GM power steering fluid Part No. 1050017 – if not available use DEXRON DEXRON II automatic transmission fluid	1 1/2 Qts.
Final drive	SAE-80 or SAE-90 GL-5 gear lubricant (SAE-80 in Canada)	4 Pts.
Brake system and master cylinder	Delco Supreme 11 or, DOT-3 fluid or equivalent	
Transmission shift linkage	Engine oil	
Chassis lubrication	Chassis grease meeting requirements of GM 6031-M	
Transmission	DEXRON or DEXRON II automatic transmission fluid	
Parking brake cables	Chassis grease	
Rear wheel bearings	Chassis grease meeting requirements of GM 6031-M	
Body door hinge pins, hinges and latches at the front access doors, external utilities, generator/storage and LP gas doors. Gas fill door hinge	Engine oil	
Windshield washer solvent	GM Optikleen washer solvent Part No. 1050001 or equivalent	
Energizers (Batteries)	Colorless, odorless, drinking water	
Engine coolant	Mixture of water and a high quality Ethylene Glycol base type anti-freeze conforming to GM Spec. 1899-M	21 Qts.

**NOTE:** Fluids and lubricants identified with GM part numbers or GM specification numbers may be obtained from your GMC Motor Home Service Outlet.

\* 12 qts. after complete overhaul.

# LUBRICATION DETAILS

## ENGINE

### ENGINE OIL AND FILTER RECOMMENDATIONS

- Use only SE engine oil.
- Refer to "Engine, Chassis and Body Maintenance Schedule" for oil change and filter replacement intervals.

The recommendations in the "Engine, Chassis and Body Maintenance Schedule" apply to the first change as well as subsequent oil changes. The oil change interval for the Motor Home engine is based on the use of SE oils and quality oil filters. Oil change intervals longer than those listed above will seriously reduce engine life and may affect GMC Truck Coach's obligation under the provisions of the New Vehicle Warranty.

A high quality SE oil was installed in the engine at the factory. It is not necessary to change this factory-installed oil prior to the recommended normal change period. However, check the oil level more frequently during the break-in period since higher oil consumption is normal until the piston rings become seated.

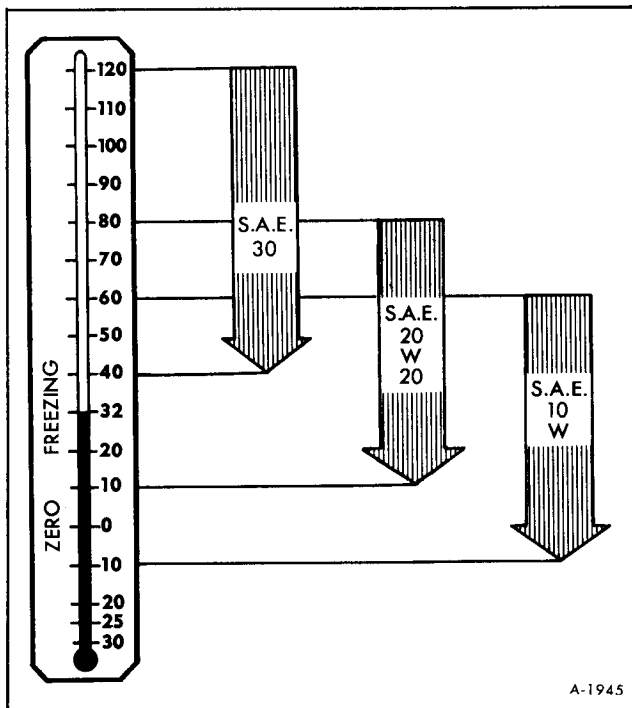

Figure 11-Engine Oil Viscosity Chart

**NOTE:** Non-detergent and other low quality oils are specifically not recommended. Only the use of SE engine oils and proper oil and filter change intervals assure of continued proper lubrication of the Motor Home's engine.

### RECOMMENDED SAE VISCOSITY (FIGURE 11)

- Single grade oils are preferred, however, multi-grades such as SAE 10W-30 or 10W-40 are also acceptable.
- SAE 5W-20 oils are not recommended for sustained high speed driving.
- SAE 5W-30 oils (if available) may be used if extreme low temperatures are anticipated.

### SUPPLEMENTAL ENGINE OIL ADDITIVES

The regular use of supplemental additives is specifically not recommended and will increase operating costs. However, supplemental additives are available that can effectively and economically solve certain specific problems without causing other difficulties. For example, if higher detergency is required to reduce varnish and sludge deposits resulting from some unusual operational difficulty, a thoroughly tested and approved additive—"Super Engine Oil Supplement"—is available at your GMC Motor Home service outlet.

### CHECKING OIL LEVEL

The engine oil should be maintained at the proper level. The best time to check it is before operating the engine or as the last step in a fuel stop. This will allow the normal oil accumulation in the engine to drain back into the crankcase. To check the level, remove the oil level dipstick located inside the left front access door (See figure 12) wipe it clean and reinsert it fully for accurate reading. The oil level dipstick is marked "FULL" and "ADD." (figure 13) The oil level should be maintained within the margin, neither going above the "FULL" line nor below the "ADD" line. Reseat the dipstick firmly after taking the reading. One (1) quart will raise the oil level from "ADD" to "FULL."

**NOTE:** The oil dipstick is also marked "USE SE ENGINE OIL," as a reminder to use only SE oils.

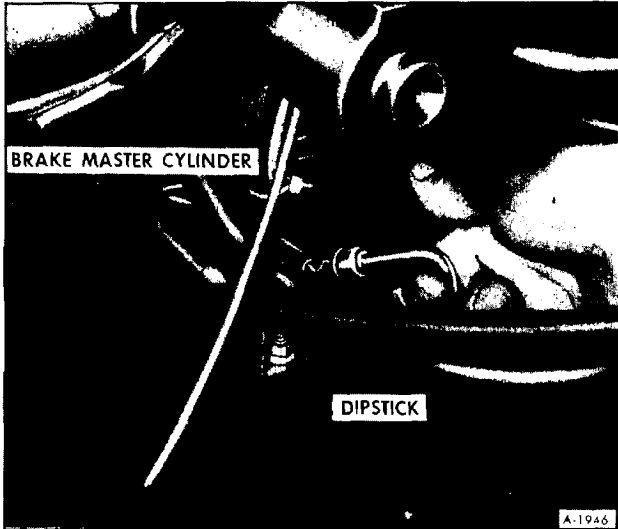

Figure 12—Removing Engine Oil Dipstick

## TRANSMISSION

The transmission dipstick and fill tube is located under the engine access cover on the left side of the engine. (figure 14)

Use only automatic transmission fluids identified with the mark **DEXRON®** or **DEXRON®II**. These fluids have been specially formulated and tested for use in the automatic transmission, and are available from the GMC Motor Home service outlet or local service station.

Check the fluid level at each engine oil change period. To make an accurate fluid level check:

1. Drive Motor Home several miles, making frequent starts and stops, to bring transmission up to normal operating temperature (approx. 180-190° F.).

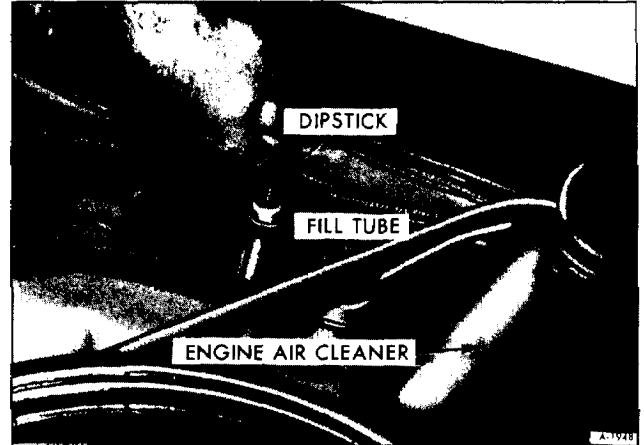

Figure 14—Removing Transmission Dipstick

2. Park Motor Home on a level surface.
3. Apply parking brake.
4. Place selector lever in "PARK" and leave engine running.
5. Open all but the two rear windows, then remove engine cover.
6. Remove dipstick and wipe clean.
7. Reinsert dipstick until cap seats.
8. Remove dipstick and note reading. (figure 15)

If fluid level is at or below the "ADD" mark, add sufficient fluid to raise the level to the "FULL" mark. One pint raises the level from "ADD" to "FULL." Do not overfill. Refer to the Maintenance Chart for servicing schedule.

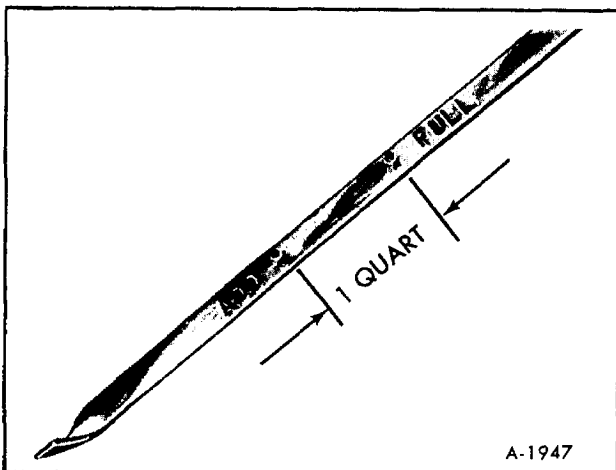

Figure 13—Engine Oil Dipstick

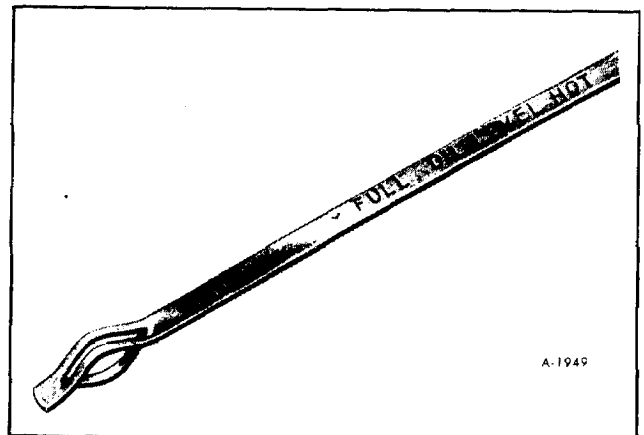

Figure 15—Transmission Dipstick

## TRANSMISSION OIL FILTER REPLACEMENT (FIGURE 16)

**NOTE:** Have a drain pan ready as lubricant will begin to drain as bolts are loosened.

1. Remove (13) bottom pan attaching screws.
2. Remove bottom pan and discard gasket.
3. Remove and discard oil filter assembly.
4. Install new O-ring seal on new filter and intake pipe and filter assembly and install.
5. Using a new pan gasket, install pan. Torque attaching screws to 12 foot-pounds.
6. Add four (4) quarts of DEXRON® or DEXRON® II automatic transmission fluid and check fluid as noted above.

## FINAL DRIVE (FIGURE 17)

### FINAL DRIVE LUBRICANT REPLACEMENT

1. Remove (10) cover attaching bolts. Have a drain pan ready as lubricant will begin to drain as bolts are loosened.
2. Remove cover and allow lubricant to drain. Discard old gasket.
3. Using a new cover gasket, install cover. Torque attaching bolts to 24 foot-pounds. Shield to be bent over breather hole.
4. Add four pints of recommended lubricant

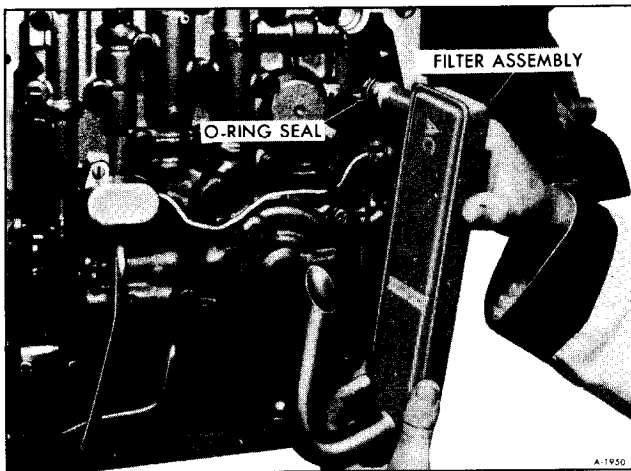

Figure 16—Replacing Transmission Oil Filter

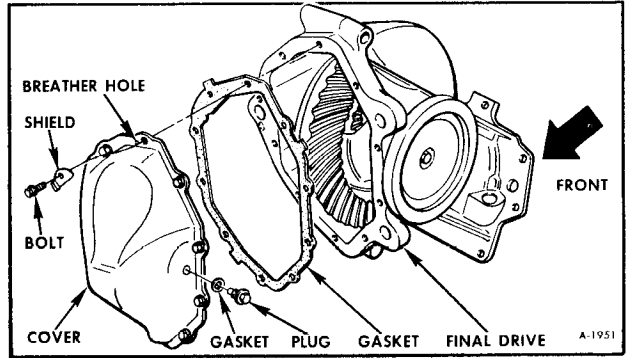

Figure 17—Final Drive Cover Removed

through fill plug hole or fill until lubricant level is at the plug hole.

## STEERING SYSTEM

### POWER STEERING SYSTEM (FIGURE 18)

Check the fluid level in the power steering pump reservoir at each oil change period. This requires the removal of the engine access cover. The reservoir is located near the Delcotron. Add GM Power Steering Fluid (if GM Power Steering Fluid is not available, DEXRON® or DEXRON®II Automatic Transmission Fluid may be used) as necessary to bring level into proper range on the filler cap indicator depending on fluid temperature.

If at operating temperature (approx. 150° F. -hot to the touch) fluid should be between "HOT" and "COLD" marks. If at room temperature (approx. 70° F.) fluid should be between "ADD" and "COLD" marks. The fluid does not require periodic changing.

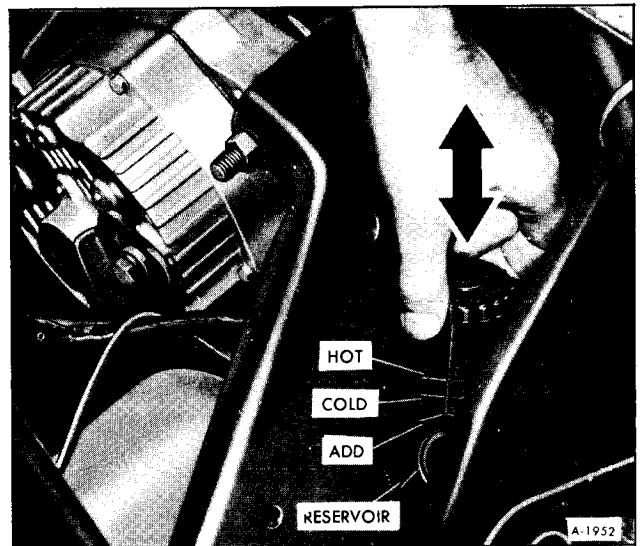

Figure 18—Checking Power Steering Fluid Level

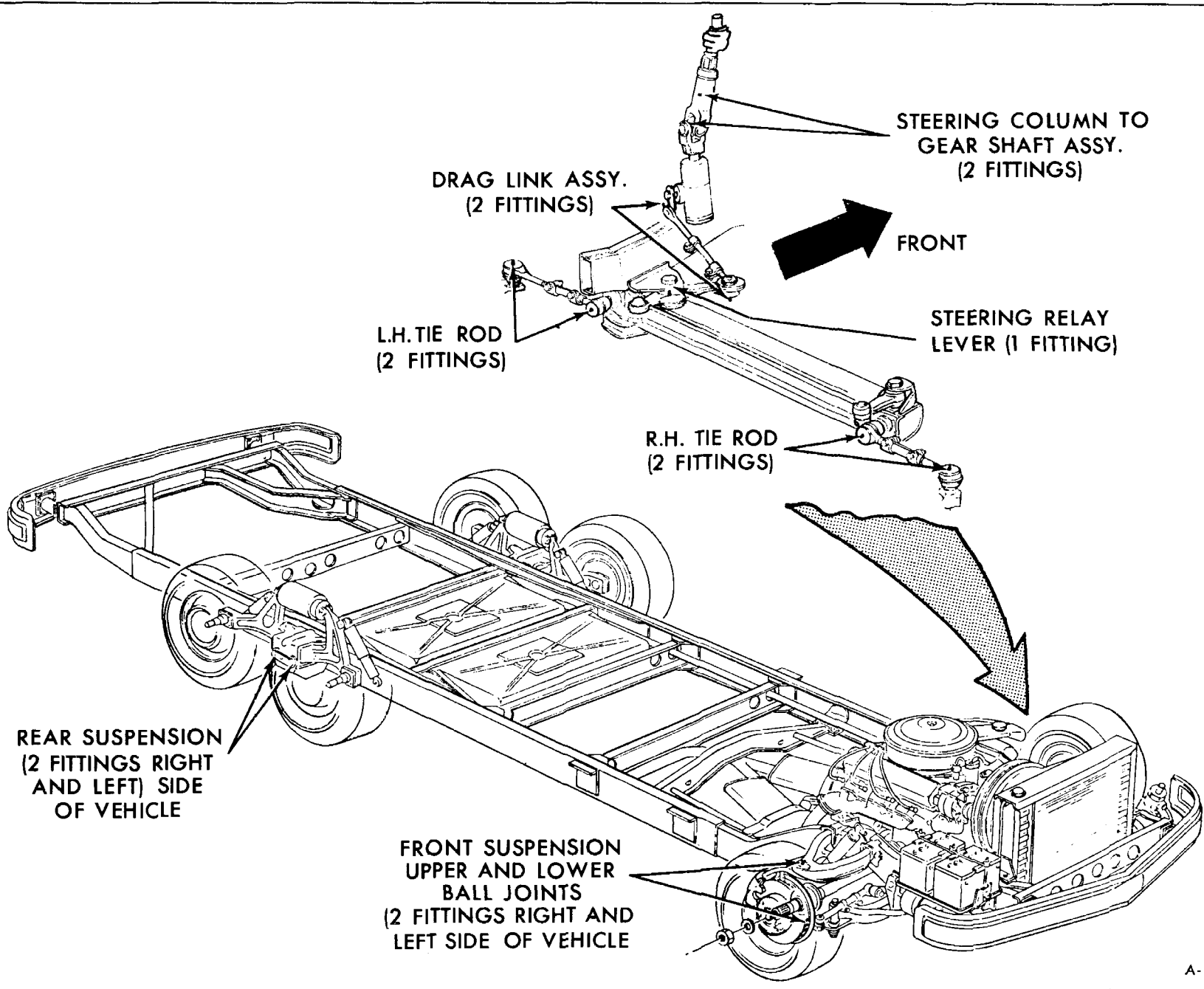

Figure 19-Location of Chassis Lubrication Fittings

## STEERING LINKAGE (FIGURE 19)

The steering linkage (tie rods) and suspension should be lubricated, using a water resistant E.P. Chassis Lubricant that meets GM Specification 6031-M, at every oil change. Seals should be checked for damage.

## BRAKE SYSTEM

### BRAKE MASTER CYLINDER (FIGURE 20)

The master cylinder is located behind the left-side access door on the front of the vehicle. The fluid level in the master cylinder should be checked at each oil change. Wipe off the brake cylinder filler cap and unsnap the retainer. A low fluid level in the front brake master cylinder reservoir could be an indicator that the disc brake pads need replacing. The fluid level must be maintained at 1/4-inch below the top of each reservoir with Delco Supreme No. 11 or DOT-3 Brake Fluid or equivalent. When replacing the cap be sure to fasten the retainer securely, taking care not to let dirt enter the reservoirs.



Figure 20—Checking Brake Master Cylinder

### BLEEDING BRAKES

The need for bleeding brakes is generally indicated by springy, spongy pedal action. Pressure bleeding equipment must be used and a definite bleeding sequence and procedure must be followed. For proper bleeding sequence see BRAKES (SECTION 5) of this manual.

## WINTERIZATION AND VEHICLE STORAGE

Winterization and vehicle storage are essential service functions which must be performed on GMC Motor Homes. Details on these items are covered in SECTION 24A "Periodic Maintenance and Lubrication"





# SECTION 1

## BODY, HEATING AND AIR CONDITIONING

This section includes the following:

SUBJECT	PAGE NO.
Body .....	1-1
Air Conditioning System (Includes Heating).....	1-23
Heating System (Without Air Conditioning).....	1-86

### BODY

Contents of this section are listed below:

SUBJECT	PAGE NO.
General Information .....	1-1
Key Information .....	1-1
Exterior Maintenance .....	1-2
Interior Maintenance .....	1-2
Dust and Water Leaks .....	1-3
Painting .....	1-4
Glass.....	1-5
Windshield Wiper System .....	1-9
Entrance Door .....	1-12
Access Doors .....	1-15
Lap Belt Maintenance .....	1-16
Floor.....	1-16
Fiberglass Repair .....	1-18
Sheet Metal Repair .....	1-19
Seats .....	1-19
Mirrors and Sun Visor .....	1-20
Radiator Grille.....	1-21
End Cap .....	1-21
Special Tools .....	1-22

### GENERAL INFORMATION

The body of the vehicle is constructed of aluminum and fiberglass with a wood floor. Extruded aluminum ribs and struts are welded together to form a cage-like framework. The exterior skin is then bonded directly to the framework.

Both front and rear end caps are fiberglass; and the lower side panels, below the belt line, are fiber-

glass. The side panels, above the belt line, are sheet aluminum. The main roof panel is also sheet aluminum.

The roof and side panels are bonded directly to the aluminum framing. Pop rivets are then used to secure the panels where the roof and side panels are joined and rivets are also used at the belt line.

### KEY INFORMATION

All models have ignition and glove compartment lock cylinders incorporating coded keyways and

keys. The code letter is located on the key shank and the code number is stamped on the knock-out por-

tion of the key head. These numbers identify the locks in which the keys are used and are required when ordering or making new keys.

The other keys used on the vehicle have a metal disc secured to the keys. This number should be recorded and the disc destroyed as this number will be needed when ordering or making new keys.

## EXTERIOR MAINTENANCE

Entire vehicle should be regularly inspected for condition of paint and for corrosion damage, with particular attention given to chrome. Inspection should be made more frequently in freezing weather due to the corrosive effect of road deicing materials (salt, calcium chloride, etc.) on metal. If inspection discloses any evidences of corrosion, paint failure, or bare metal, corrective measures as outlined under "Painting" (later in this section) should be immediately employed.

Body painted surfaces and chrome plating should be protected by a coating of wax, applied at regular intervals. Periods between applications should be sufficiently short to assure continuous protection of the finish; 30 days after delivery, and at least once a

Notch dept information will be provided, on current production keys, upon request through the manufacturer of your key cutting equipment or his locksmith association. Also he will be able to furnish a conversion package for your cutter, if required, for grinding new keys.

year thereafter. Any good body wax can be used for both painted and chrome surfaces. Wax should be applied immediately after vehicle has been cleaned.

**NOTE:** Calcium chloride and other salts, road tar, excretion from insects, ("treesap"), chemicals from factory chimneys and other foreign matter may permanently damage paint and chrome. Frequent, regular washing and a thorough cleaning after exposure is recommended to prevent damage by these substances. Use either cold or lukewarm water. Never wash vehicle in direct rays of the sun and always wait until painted surfaces have cooled.

## INTERIOR MAINTENANCE

Dust and loose dirt that accumulate on interior fabric trim should be removed frequently with a vacuum cleaner, whisk broom or soft brush. Vinyl or leather trim should be wiped clean with a damp cloth. Normal cleanable trim soilage, spots or stains can be cleaned with the proper use of trim cleaners available through General Motors Dealers or other reputable supply outlets.

**IMPORTANT:** Do not use commercial paint, chrome or glass cleaners on interior bright trim or painted surfaces. If cleaning is required, lukewarm water and a neutral soap may be used.

Before attempting to remove spots or stains from upholstery, determine as accurately as possible the nature and age of the spot or stain. Some spots or stains can be removed satisfactorily with water or mild soap solution (refer to "Removal of Specific Stains" later in this section). For best results, spots or stains should be removed as soon as possible.

Some types of stains or soilage such as lipsticks, some inks, certain types of grease, mustard, etc., are extremely difficult and, in some cases, impossible to completely remove. When cleaning this type of stain

or soilage, care must be taken not to enlarge the soiled area. It is sometimes more desirable to have a small stain than an enlarged stain as a result of attempted cleaning.

**CAUTION:** *When cleaning interior do not use volatile cleaning solvents such as: acetone, lacquer thinners, enamel reducers, nail polish removers; or such cleaning materials as laundry soaps, bleaches or reducing agents (except as noted in the instructions on "Cleaning Fabrics" and "Removal of Specific Stains.") Never use carbon tetrachloride, gasoline, or naphtha for any cleaning purpose. The above materials may be toxic or flammable, or may cause damage to interior.*

## INTERIOR GLASS

The interior glass surface should be cleaned on a periodic basis for continued good visibility. A commercial household glass cleaning agent containing ammonia will remove normal tobacco smoke and

dust films sometimes caused by ingredients used in vinyls, plastics, or other interior trim materials.

## CLEANING FABRICS

**IMPORTANT:** Be sure vehicle is well ventilated while using the following cleaning agents. Follow manufacturer's recommendations in using such products.

### CLEANING FABRICS WITH CLEANING FLUID

This type of cleaner should be used for cleaning stains containing grease, oil, or fats. Excess stain should be gently scraped off trim with a clean dull knife or scraper. Use very little cleaner, light pressure, and clean cloths (preferably cheesecloth). Cleaning action with cloth should be from outside of stain towards center and constantly changing to a clean section of cloth. When stain is cleaned from fabric, immediately wipe area briskly with a clean absorbent towel or cheesecloth to help dry area and prevent a cleaning ring. If ring forms, immediately clean entire area or panel section of the trim assembly.

**NOTE:** Sometimes a difficult spot may require a second application of cleaning fluid followed immediately by a soft brush to completely remove the spot.

### CLEANING FABRICS WITH DETERGENT FOAM CLEANERS

This type of cleaner is excellent for cleaning general soilage from fabrics and for cleaning a panel section where a minor cleaning ring may be left from spot cleaning. Vacuum area to remove excess loose dirt. Always clean at least a full trim panel or section of trim. Mask adjacent trim along stitch or weld lines. Mix detergent type foam cleaners in strict accordance with directions on label of container. Use foam only on a clean sponge or soft bristle brush—Do not wet fabric excessively or rub harshly with brush. Wipe clean with a slightly damp absorbent towel or cloth. Immediately after cleaning fabric, dry fabric

with a dry towel or hair dryer. Rewipe fabric with dry absorbent towel or cloth to restore the luster of the trim and to eliminate any dried residue.

## REMOVAL OF SPECIFIC STAINS

**CANDY—Chocolate,** use cloth soaked in lukewarm water; other than chocolate, use very hot water. Dry if necessary, clean lightly with fabric cleaning fluid.

**CHEWING GUM—Harden** gum with ice cube and scrape off with dull knife. Moisten with fabric cleaning fluid and scrape again.

**FRUIT STAINS, COFFEE, LIQUOR, WINE, SOFT DRINKS, ICE CREAM AND MILK—Wipe** with cloth soaked in cold water. If necessary, clean lightly with fabric cleaning fluid. Soap and water is not recommended as it might set the stain.

**CATSUP—Wipe** with cloth soaked in cool water. If further cleaning is necessary, use a detergent foam cleaner.

**GREASE, OIL, BUTTER, MARGARINE AND CRAYON—Scrap** off excess with dull knife. Use fabric cleaning fluid.

**PASTE OR WAX TYPE SHOE POLISH—Light** application of fabric cleaning fluid.

**TAR—Remove** excess with dull knife, moisten with fabric cleaning fluid, scrape again, rub lightly with additional cleaner.

**BLOOD—Wipe** with clean cloth moistened with cold water. Use no soap.

**URINE—Sponge** stain with lukewarm soap suds from mild neutral soap on clean cloth, rinse with cloth soaked in cold water; saturate cloth with one part household ammonia and five parts water, apply for one minute, rinse with clean, wet cloth.

**VOMITUS—Sponge** with clean cloth dipped in clean, cold water. Wash lightly with lukewarm water and mild neutral soap. If odor persists, treat area with a water-baking soda solution (one teaspoon baking soda to one cup of tepid water). Rub again with cloth and cold water. Finally, if necessary, clean lightly with fabric cleaning fluid.

## DUST AND WATER LEAKS

Test windshield, windows and vehicle under flooring for leaks by spraying water under pressure

against vehicle while assistant inside marks points of leakage, if any exist.

If location of leak has been determined to be around windshield or rear glass, dry surface and apply rubber cement. Apply cement to outside, both between glass and weatherstrip and between weatherstrip and body.

If the leak is around any side window it will be necessary to remove the window and install a new seal.

A quick method for locating many air and water leaks at windshield, backglass, bolt holes, weatherstripping and joints is as follows:

Close all windows and vents, turn air conditioning or heater blower motor to high position and outside air and close doors. Run water over suspected leak area in a small controllable stream and observe area for pressure bubbles.

Water which shows up at a certain place inside vehicle may actually be entering at a point other than where water is found. Back-track path of water to point of entry. Apply body sealing compound over all leak points. If leakage occurs at door opening, check weatherstrip. Seal with rubber cement or replace if necessary. If door does not firmly contact weatherstrip, align door. Refer to "Door Adjustment" later in this section.

## PAINING

Aluminum corrodes just as iron and steel rusts. Under certain conditions aluminum will corrode more rapidly than steel. Inspect body surfaces regularly for corrosion and paint condition.

Only sound parts can be refinished. If corrosion is excessive, replace with new parts. Remove old parts. Refinish all exposed adjacent parts which remain on vehicle. When installing new parts use only zinc or cadmium coated bolts, washers, and nuts.

The instructions which follow cover both aluminum and fiberglass, and both new and old parts.

1. Through cleaning is essential; all corrosion, grease, and other foreign matter must be removed. Solvent cleaning, pressure steam cleaning, wire brushing, and hand sanding methods are recommended.

2. Completely remove old paint by use of organic solvents. Do not use alkaline paint remover on aluminum. If old primer is very difficult to remove and there is no evidence of metal corrosion, old primer may be left on, but all loose paint must be removed.

3. Wipe the entire area to be refinished with cloths saturated with DuPont No. T-3812 reducer (or equivalent). Wipe dry.

4. Treat any scratched or abraded areas with DuPont No. VM-5717 metal conditioner (or equivalent) reduced one (1) part by volume with four (4) parts of water.

a. Apply the above mixture with a sponge or brush and allow to stand approximately three (3) minutes.

b. Wipe area with a damp cloth. Dry thoroughly.

5. Apply a coat of pre-primer (sometimes called wash-primer), preferably by spraying to a uniform and complete coverage coat on all surfaces. This type primer uses a special accelerating agent containing phosphoric acid which produces an excellent bond to metal. AP-10 or A-158 made by M & T Chemical Co., XE-5220 made by Bakelite Corporation, and 818-012 (2 parts), plus T8539 (1 part) made by DuPont, or any equivalent material made by a reputable paint manufacturer should be acceptable. These materials must be used within a few hours after addition of accelerator, therefore, directions of manufacturer should be observed carefully. Apply by spraying. Allow parts to dry.

6. Use a zinc chromate primer such as DuPont No. 63-150 or Pontiac Varnish Company's GMT-434, or any equivalent material made by a reputable manufacturer. Apply primer, preferably by spraying, to a minimum thickness of 0.5 mils. Allow parts to dry.

7. Apply finish coats:

a. For understructure and other parts not requiring color, apply a second coat of DuPont No. 63-150 or Pontiac Varnish Company's GMT-434, or equivalent.

b. To exposed body parts, apply desired color coats in accordance with standard practice.

# GLASS

## WINDSHIELD REPLACEMENT

Windshield glass is retained in the opening by a molded rubber weatherstrip with an insert-type rubber seal as shown in Figure 1. Two glass sections are used in this vehicle.

When replacing a cracked windshield glass, it is very important that the cause of the glass breakage be determined and the condition corrected before a new glass is installed. Otherwise, it is highly possible that a small obstruction or high spot somewhere around the windshield opening will continue to crack or break the newly installed windshield; especially when the strain on the glass caused by the obstruction is increased by such conditions as wind pressures, extremes of temperature, motion of the vehicle, etc.

## REMOVAL

If cracks in glass extend to outer edge of glass, mark body with chalk at these points so that weatherstrip flange opening can be examined later for possible distortion.

Protect the interior finish by placing a protective covering over steering wheel and dash panel. Mask around the windshield opening and lay a suitable cover to protect body.

**WARNING: ALWAYS WEAR HEAVY GLOVES TO PREVENT POSSIBLE INJURY WHEN HANDLING GLASS.**

1. Pry end of insert out of rubber seal with a pointed tool; pull insert completely out of seal.
2. With aid of an assistant to hold glass outside vehicle, push glass forward from inside vehicle.

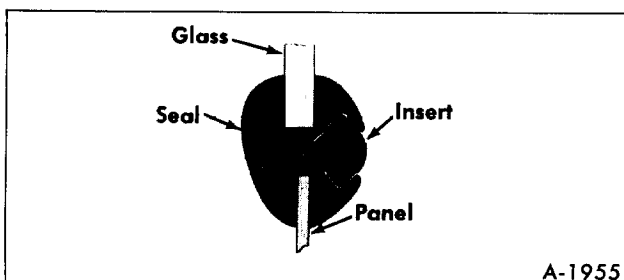

Figure 1-Windshield Weatherstrip

## INSPECTION

Due to the expanse and contour of the windshield, it is imperative in the event of a strain break that the windshield opening be thoroughly checked before installing a replacement windshield.

1. Check for the following conditions at the previous marked point of fracture:
  - a. Chipped edges on glass.
  - b. Irregularities in body opening.
  - c. Irregularities in rubber channel weatherstrip.
2. Remove all sealer from flange and body around windshield opening.
3. Check flange area for high spots. Remove all high spots.

## GLASS-TO-OPENING CLEARANCE CHECK

Before installing new glass, check glass opening for proper clearance, using five special spacer blocks (J-9316) as shown in Figure 2. With the aid of an assistant, place blocks around perimeter of new glass, two at bottom and top and one at outer side opening. A 5/16 to 3/8 inch clearance should exist between glass and opening flange. Insert the blocks into gap, then rotate blocks perpendicular to flange surfaces. If all blocks cannot be installed, rework metal flange or grind off edge of glass at the side where block or blocks could not be installed.

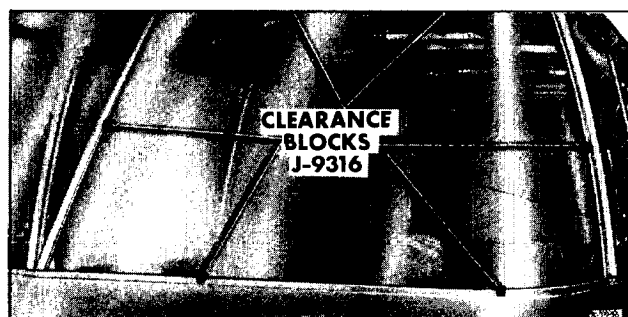

Figure 2-Checking Glass Clearance

**CAUTION:** *DO NOT strike glass against body metal. Chipped edges on the glass can lead to future breaks.*

If glass clearance is too small and glass is to be ground off, place a strip of tape on a line where glass is to be removed. Grind up to edge of tape.

**NOTE:** Add build-up to flange where necessary. Usually the building up to only one side and one-half way around one corner will provide proper glass and seal fit. Taper off ends of build-up to conform to edge of glass, otherwise glass breakage may occur, originating at a point adjacent to the end of flange build-up.

### INSTALLATION (fig. 3)

**NOTE:** If desired, sealing cement can be applied between lip of seal and glass and seal lip at opening flange.

1. Reposition rubber seal on opening flange. Raise new glass to outside of seal; then with hook end of installer tool (J-2189) in glass groove of seal as shown in figure 3, move tool around glass to force outer lip of seal over edge of glass.

2. Thread end of rubber insert through handle and loop of installer tool (fig. 3). Push tool loop and end of insert into groove of seal. Feed in rubber insert, while proceeding around window. Use a hitching movement of tool to avoid elongating insert. If new insert is being used, cut off insert allowing sufficient overlap for a tight joint; then butt into groove.

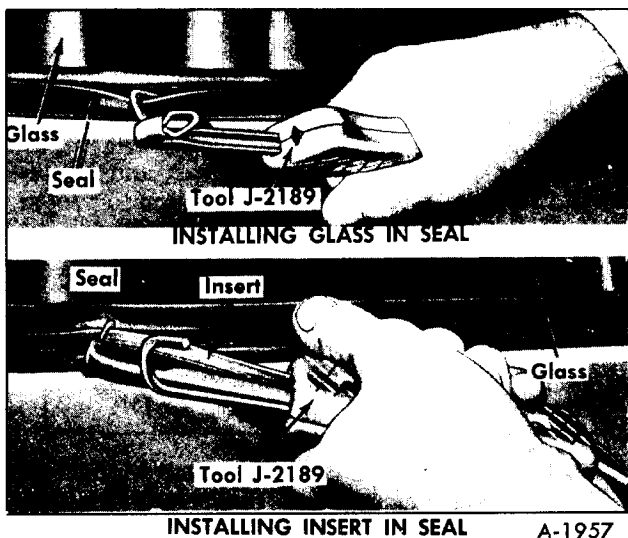

Figure 3—Positioning Seal and Insert

3. Install insert in center vertical seal (2-piece windshield) in same manner previously described in Step 2.

## SIDE WINDOWS

There are two types of windows or sash installed in the vehicle. Either a fixed or sliding window is mounted in an extruded aluminum channel. All side sash uses solid tempered glass. Both the glass and the channel is replaceable.

### SASH ASSEMBLY

#### Removal

1. Remove trim mouldings as shown in Figure 4. "A" sash assemblies (sash assemblies in the drivers/-passenger area) will require interior trim panel removal.

2. All sash assemblies are mounted as typically shown in Figure 5. Remove retainers.

3. Tap on the inside channel using a wooden block and rubber mallet.

**NOTE:** The sash assemblies are heavy. Have someone assist by supporting the assembly from the outside.

4. Remove sash assembly.

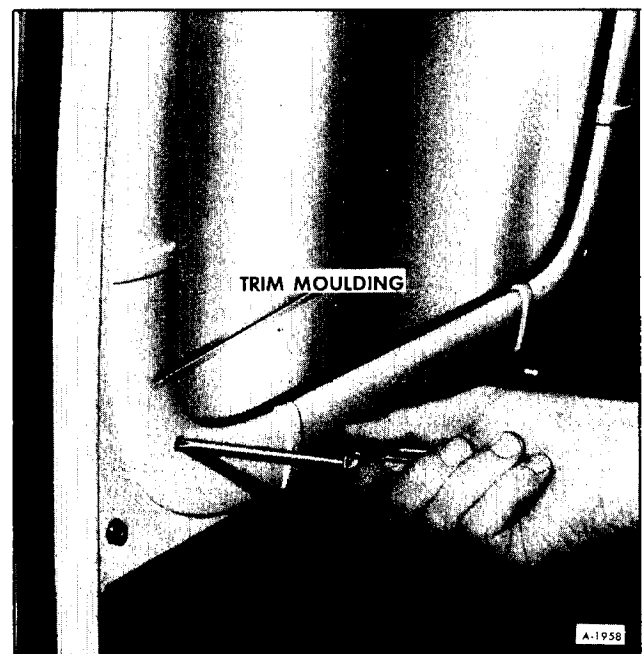

Figure 4—Removing Window Trim Moulding Screws

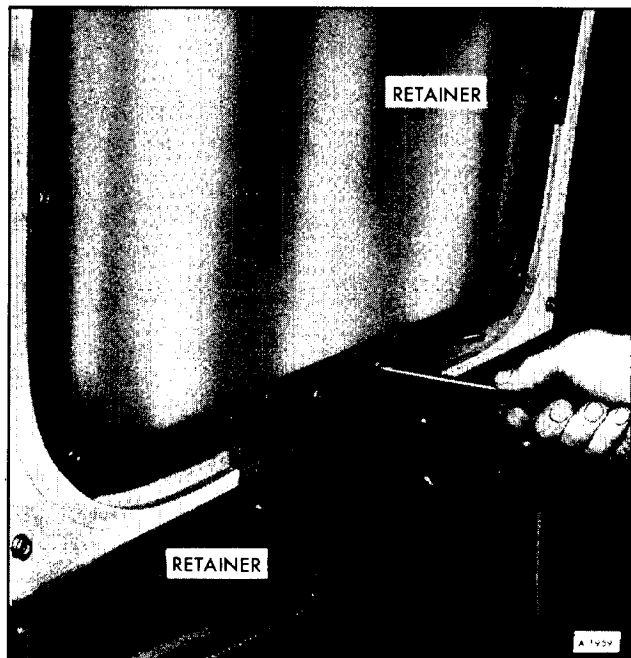

Figure 5—Removing Sash Retainers

5. Remove filler seal from sash assembly.

**Installation**

1. Apply a new filler seal to the sash assembly.

2. Install sash assembly. Position spacers as shown in Figure 6.

**NOTE:** Late model vehicles are not equipped with spacers (figure 6). A 3/16 inch gap should be maintained between sill and sash.

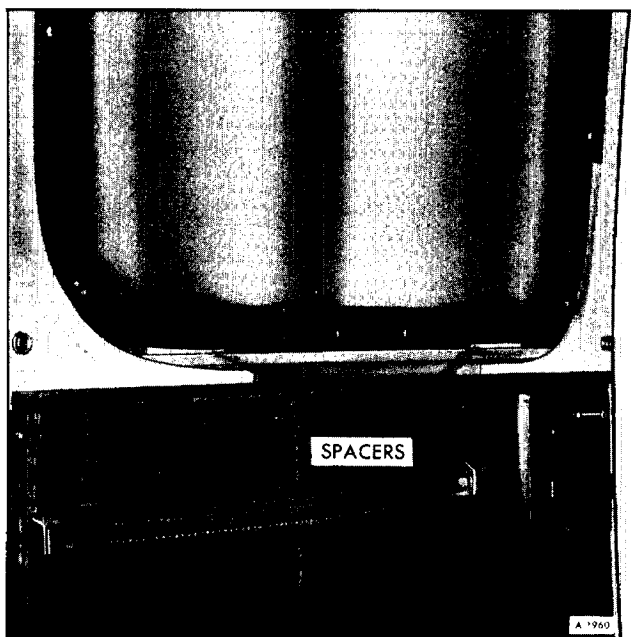

Figure 6—Sash Spacers

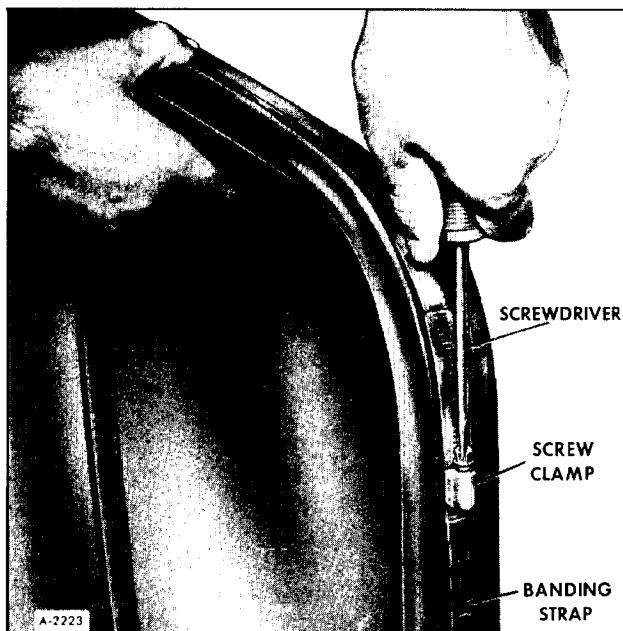

Figure 7—Removing Sash Banding Strap

3. Install retainers.

4. Install panels if removed and install trim mouldings.

**GLASS**

**Removal**

1. Remove sash assembly. Refer to "Sash Assembly - Removal" earlier in this section.

2. Remove the banding strap, if equipped, as shown in figure 7, then disassemble sash assembly as shown in Figure 8.

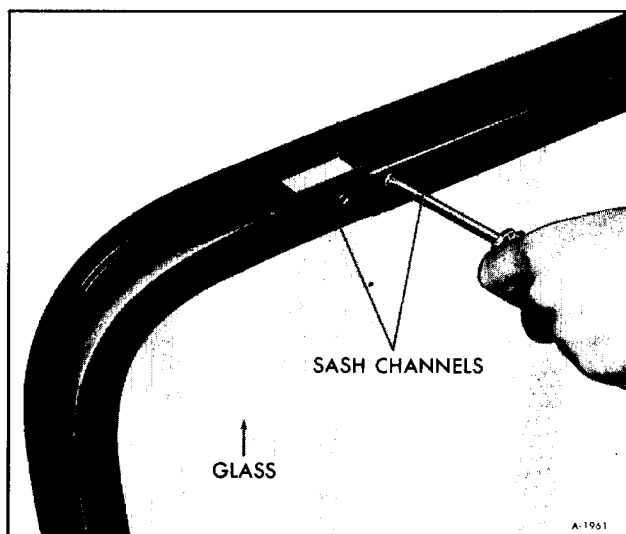

Figure 8—Disassembling Sash

3. Remove glass.
4. Clean glass sash channels thoroughly.

### Installation

1. Install glass into sash.
2. Referring to Figure 7 and 8, assemble sash.
3. Install sash assembly. Refer to "Sash Assembly-Installation" earlier in this section.

## SIDE WINDOW LATCH

### Removal

1. Remove two (2) screws attaching latch to glass.
2. Remove two (2) threaded plastic buttons.
3. Remove latch.

### Installation

1. Install a new seal to latch.
2. Install latch to glass.
3. Replace threaded plastic buttons.

## REAR WINDOW REPLACEMENT

The rear window is retained in the opening by a molded rubber weatherstrip with an insert-type rubber seal.

When replacing a cracked window, it is very important that the cause of the glass breakage be determined and the condition corrected before a new glass is installed. Otherwise it is highly possible that a small obstruction or high spot somewhere around the opening will continue to crack or break the newly installed window; especially when the strain on the glass caused by the obstruction is increased by such conditions as wind pressures, extremes of temperature, motion of vehicle, etc.

## REMOVAL

If crack extends to outer edge of glass, mark body with chalk at this point so that weatherstrip flange

opening can be examined later for possible distortion.

Protect interior finish by using a protective covering mask around window opening and lay a suitable cover to protect body.

**WARNING: ALWAYS WEAR HEAVY GLOVES TO PREVENT POSSIBLE INJURY WHEN HANDLING GLASS.**

1. From inside of vehicle pull insert out of rubber seal by pulling on ring located at top center of window; pull insert out completely.

2. With aid of an assistant to hold glass outside vehicle, push glass out from inside vehicle.

## INSPECTION

Due to the expanse of rear window, it is imperative in the event of a strain break that the window opening be thoroughly checked before installing a replacement window.

1. Check for the following conditions at the previously marked point of fracture.

A. Chipped edges on glass.

B. Irregularities in body opening.

C. Irregularities in rubber channel weatherstrip.

2. Remove all sealer from flange and body around window opening.

3. Check flange area for high spots. All high spots should be removed.

## GLASS-TO-BODY OPENING CLEARANCE

Before installing new glass, check glass opening for proper clearance, using five special spacer blocks (J-9316). With the aid of an assistant, place blocks around perimeter of new glass, two at bottom and top and one at side of opening. A 5/16 to 3/8 inch clearance should exist between glass and opening. Insert the blocks into gap, then rotate blocks perpendicular to flange surfaces. If all blocks cannot be installed, rework flange or grind off edge of glass at the side where block or blocks could not be installed.



**CAUTION:** *Do not strike glass against body. Chipped edges on the glass can lead to future breaks.*

If glass clearance is too small and glass is to be ground off, place a strip of tape on a line where glass is to be removed. Grind up to edge of tape.

**NOTE:** Add build-up to flange where necessary. Usually the building up to only one side and one-half way around one corner will provide proper glass and seal fit. Taper off ends of build-up to conform to edge of glass, otherwise glass breakage may occur, originating at a point adjacent to end of flange build-up.

## INSTALLATION

**NOTE:** If desired, sealing cement can be applied between lip of seal and glass and seal and opening flange.

1. Reposition rubber seal on opening flange. Raise new glass to outside of seal: then with hook end of installer tool (J-2189) in glass groove of seal as shown in Figure 3, move tool around glass to force outer lip of seal over edge of glass.

2. Thread end of rubber insert through handle and loop of installer tool (figure 3). Move installer to middle of insert. Starting at top-center of rubber seal push tool loop and insert into seal groove. Feed in rubber insert, while proceeding around one side of window. Use a hitching movement of tool to avoid elongating insert, position emergency exit pull ring on rubber insert at top center of window. Thread other end of rubber insert through handle and loop of installer tool. Push tool loop and insert into seal groove and position pull ring in place. Feed in rubber insert, while proceeding around other side of window. If new insert is being used, cut off insert allowing sufficient overlap for a tight joint; then butt into groove at bottom of window.

# WINDSHIELD WIPER SYSTEM

## GENERAL INFORMATION

The vehicle is equipped with variable speed hydraulic wipers with washers as standard equipment. A single motor powers both blades.

The wiper motor is mounted to a bracket on the left side of the vehicle in front of the driver's toe board. A lever control on the left side of the instrument panel varies the speed of the wiper blades. The hydraulic motor is powered by power steering fluid from the discharge side of the power steering pump.

## WINDSHIELD WASHER ASSEMBLY REPLACEMENT

The windshield washer reservoir and pump are one unit. The 12 volt pump in the windshield washer reservoir must be replaced with the entire washer assembly.

## REMOVAL

1. Disconnect battery ground cables and then disconnect wire leads (2) to washer motor.

2. Disconnect hose at the rear of the washer reservoir.

3. Lift reservoir out of its bracket and remove it from the vehicle.

## INSTALLATION

1. Position reservoir in its bracket.

2. Install two wires to terminals on motor.

3. Connect hose to back of reservoir.

4. Connect battery ground cables and check for proper operation.

## WASHER NOZZLE ADJUSTMENT

The windshield washer nozzle is located on the end of the wiper arm. The nozzle is retained by the same nut and bolt which attaches the blade to the wiper arm. The nozzle should be parallel with the windshield as shown in Figure 9.

Nozzles are adjustable by loosening the attaching bolt, position nozzle as described above and tighten bolt.

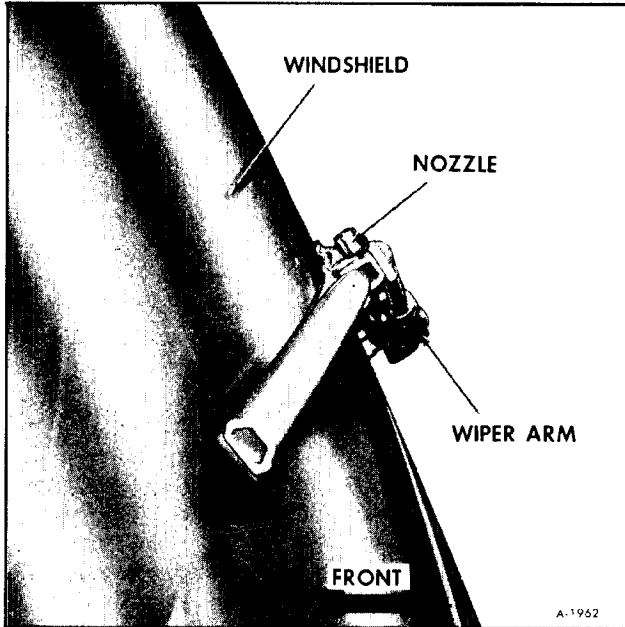

Figure 9-Windshield Washer Nozzle Alignment

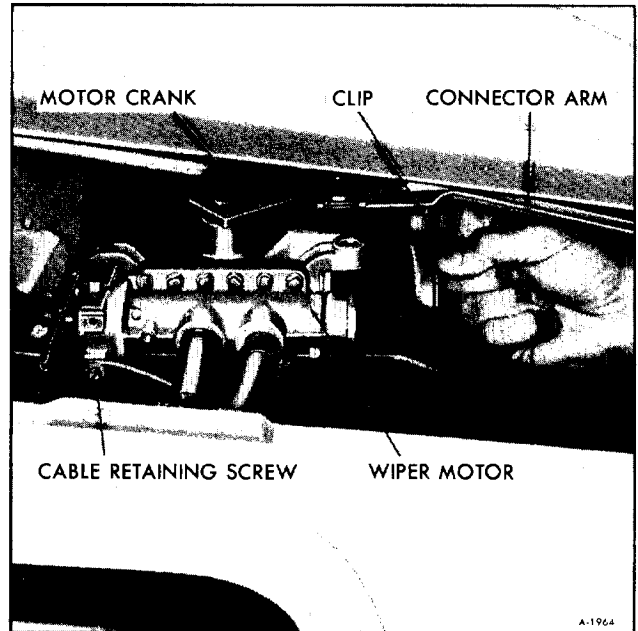

Figure 11-Removing Linkage

## TRANSMISSION PIVOT SHAFT AND LINK REPLACEMENT

### REMOVAL

1. Remove wiper arms from pivot shafts, by removing plastic caps from wiper arm retaining nuts. Remove retaining nuts. Remove wiper arms (See figure 10).

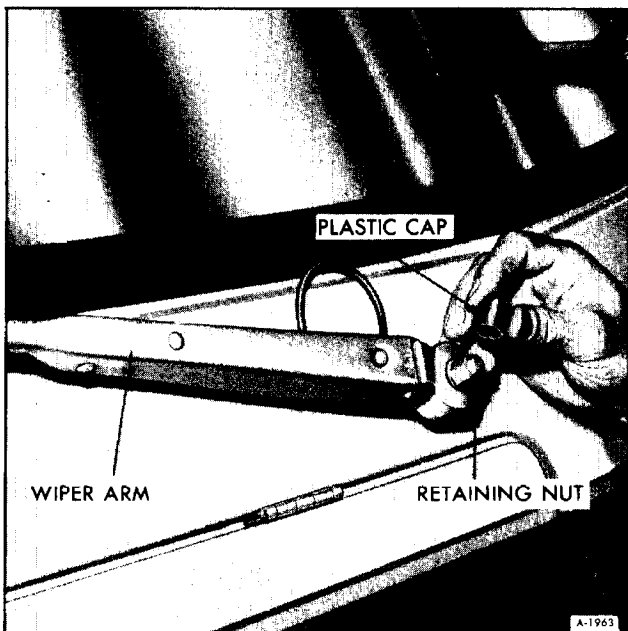

Figure 10-Wiper Arm Removal

2. Remove linkage from wiper motor crank arm by sliding back clip(s) away from motor (figure 11).

3. Remove three bolts from transmission pivot shaft mounting bracket as shown in Figure 12. Remove assembly.

### INSTALLATION

1. Position transmission pivot shaft and secure with three bolts at its mounting bracket.

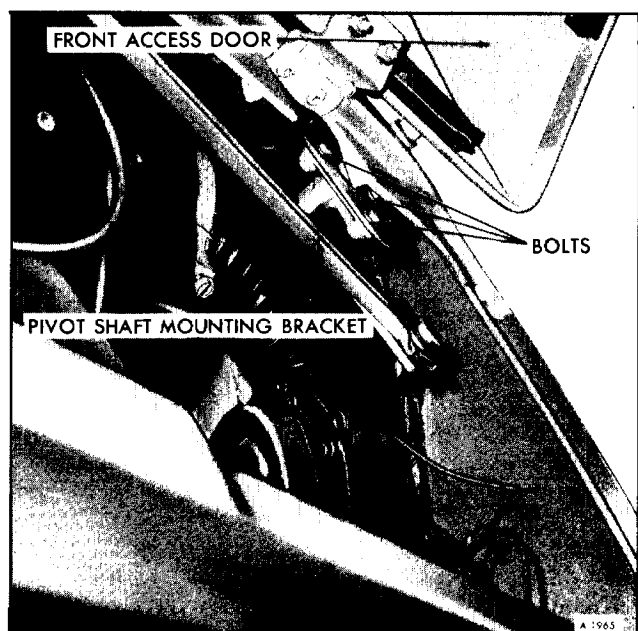

Figure 12-Pivot Shaft Mounting Bracket

2. Install linkage to crank arm on wiper motor.
3. Install wiper arms on pivot shafts.

## WIPER BLADE REPLACEMENT

The wiper blade is retained by the use of a spring type retainer clip in the end of the blade element. When the retainer clip is squeezed together, the blade can be removed by sliding out of the blade assembly.

The blade assembly is retained to the wiper arm by a nut and bolt at the end of the arm. The removal of this nut and bolt will allow removal of the blade assembly and the windshield washer nozzle.

## WIPER ARM ADJUSTMENT

To adjust sweep of blades to provide maximum visibility, turn on wipers, then note sweep of arms.

**CAUTION:** *Do not attempt to manually force wiper arms into position as damage to linkage or motor may occur.*

If necessary, remove arms as follows;

1. Remove plastic protective cap from nut on end of wiper arm.
2. Remove nut from end of wiper arm and remove arm.
3. Arm can be reinstalled in any one of several positions due to serrations on pivot shaft driver head and in wiper arm head.

**NOTE:** Checking blade sweep should be done with the windshield wet.

## WINDSHIELD WIPER MOTOR REPLACEMENT

**NOTE:** The windshield wiper motor is serviced as an assembly. Do not attempt to repair the motor.

## REMOVAL

1. Disconnect hoses (2) at motor and tape end to prevent loss of fluid and entrance of dirt or water into system.
2. Loosen cable retaining screw at bottom of motor and remove pin from arm on motor assembly. See Figure 10.
3. Remove connector arms by sliding back clips and disconnecting arms from the motor assembly.
4. Remove three bolts retaining motor assembly to its bracket.

## INSTALLATION

1. Position wiper motor on bracket and install three retaining bolts.
2. Position connector arms on motor crank arm and secure with slide clips.
3. Insert pin at end of cable assembly and secure with retaining screw on motor assembly.
4. Connect hoses to motor assembly as shown in Figure 13.
5. Check power steering fluid level. Operate wipers on a wet windshield for several minutes. Then recheck power steering fluid level. Also check for fluid leaks. Correct as necessary.

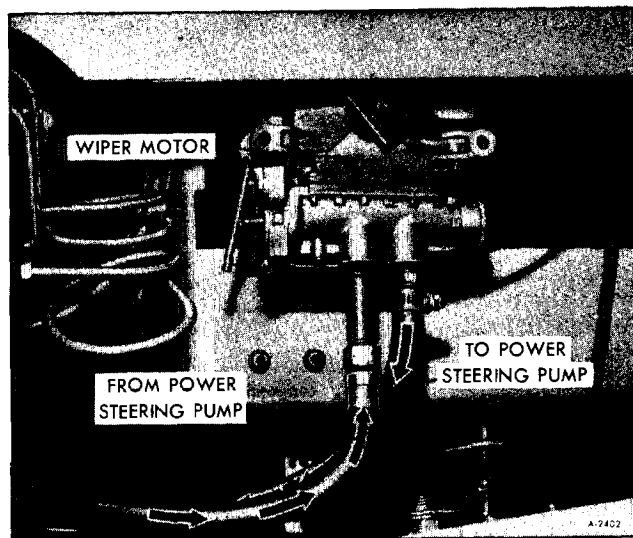

Figure 13—Windshield Wiper Motor

## ENTRANCE DOOR

### ADJUSTMENT

The door may be adjusted vertically by loosening the bolts at both hinges as shown in Figure. 14.

Horizontal adjustment may be made by shimming or removing metal at the shaded area of the hinges as shown in Figure 15.

### DOOR SEAL

The entrance door seal is replaceable. Clean old seal from door frame, apply adhesive to frame then install new seal.

### DOOR REMOVAL

1. Remove four (4) hinge to door frame attaching bolts.
2. Remove door.

### DOOR INSTALLATION

1. Install door.

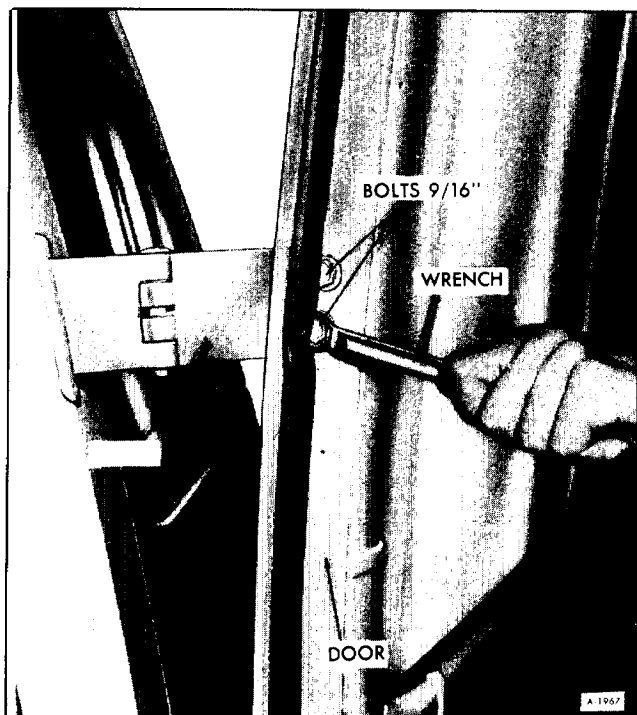

Figure 14—Entrance Door Adjustment-Vertical

2. Install four (4) bolts, torque to 25-30 ft. lbs.
3. Check for leaks and correct as necessary.

### ENTRANCE DOOR LOCK

#### REMOVAL - TYPE I LOCK

1. Remove screws as shown in Figure 16. Remove inner plate and handle assembly.
2. Push lock assembly out from the inside and remove (See figure 17).

#### INSTALLATION - TYPE I LOCK

1. Apply new sealer if required and install lock assembly as shown in Figure 17.
2. Install inner plate and handle assembly.
3. Install screws and tighten securely.

#### REMOVAL - TYPE II LOCK

1. Remove door lock trim panel screws as shown in Figure 18.

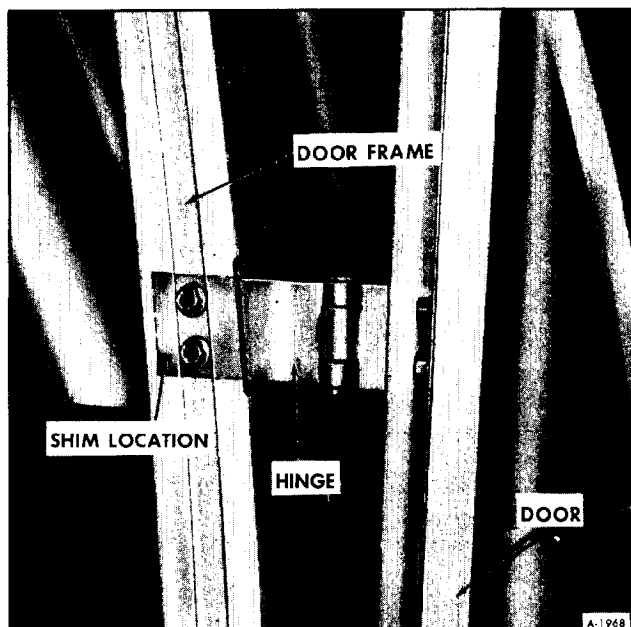

Figure 15—Entrance Door Adjustment-Horizontal

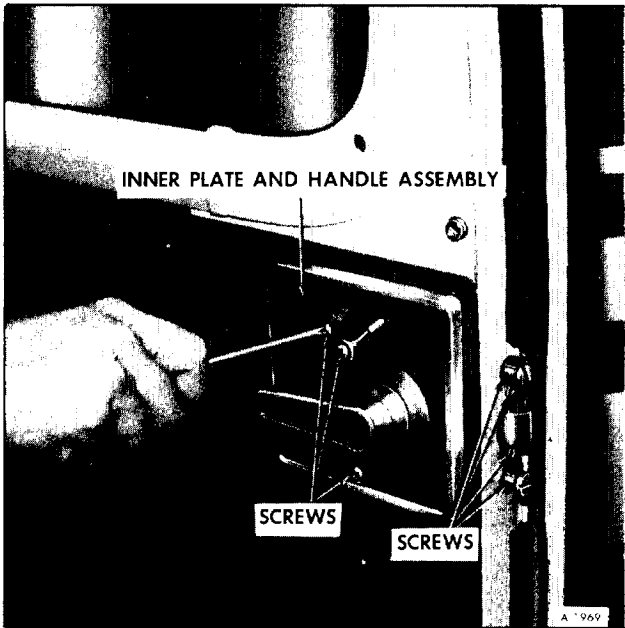

Figure 16-Removing Screws on Type I Lock

2. Remove lock retaining screws.

3. Remove inner plate and handle assembly. Remove door trim panel.

4. Remove screw as shown in Figure 19. Push lock out from the inside.

**INSTALLATION - TYPE II LOCK**

1. Install lock assembly.

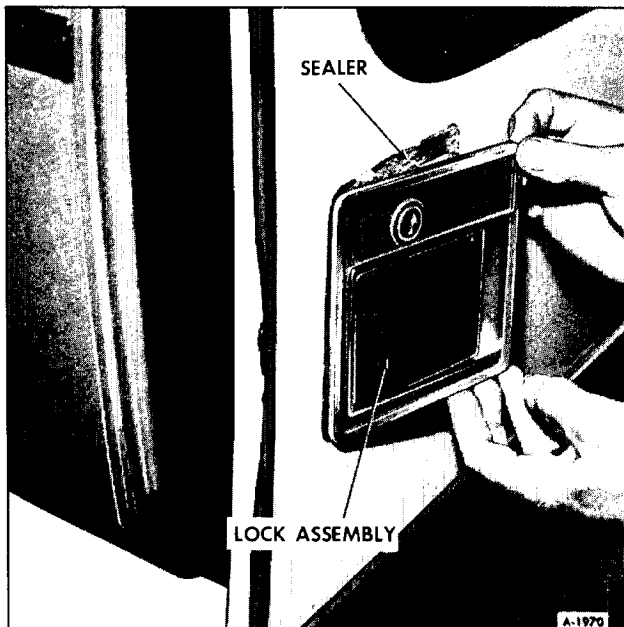

Figure 17-Removing Lock Assembly

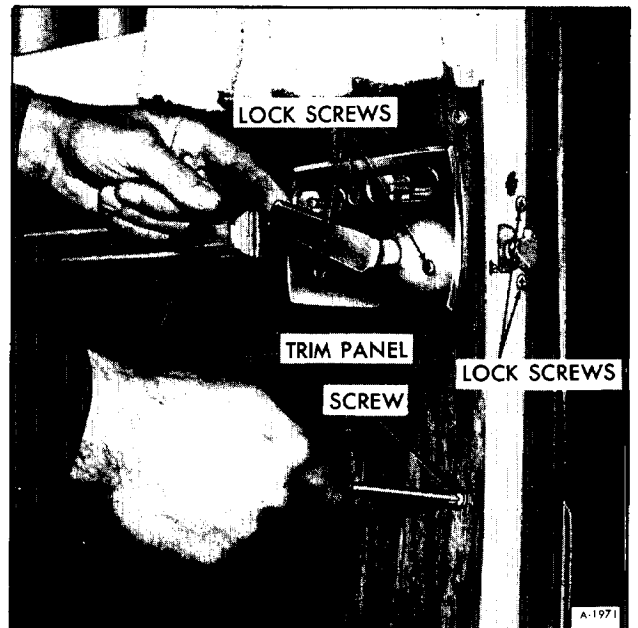

Figure 18-Removing Trim Panel

2. Install door trim panel.

3. Install inner plate and handle assembly.

**REMOVAL - TYPE III LOCK (FIGURE 20)**

1. Remove lower door trim panel.

2. Remove lock button.

3. Remove lower window moulding (figure 4).

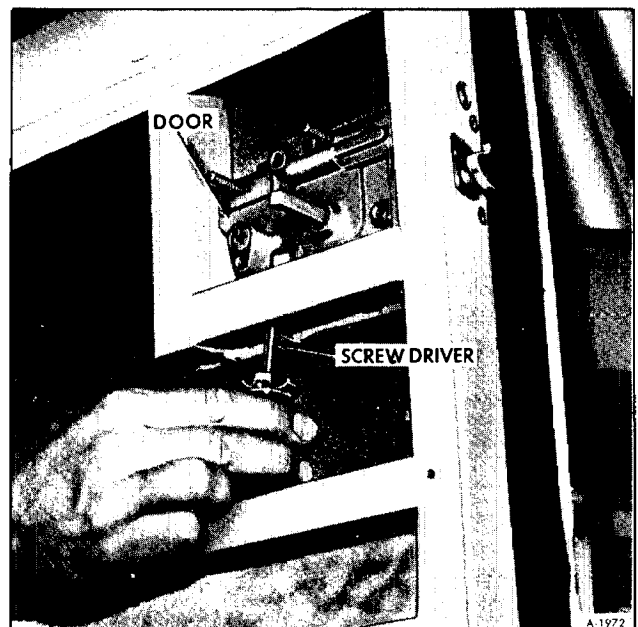

Figure 19-Removing Screw on Type II Lock

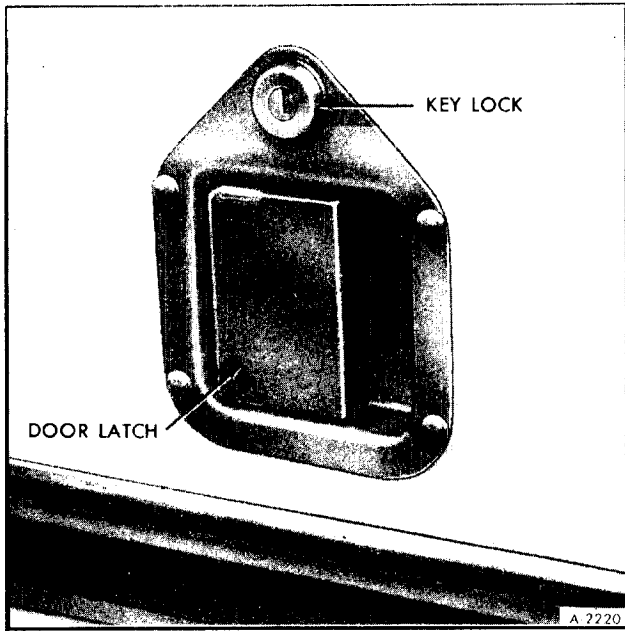

Figure 20--Type III Door Lock

4. Remove upper trim panel and inner handle assembly by loosening screws shown in Figure 21 and removing all other screws. Use care when removing panel to avoid damaging door handle mechanism.

5. Remove cotter pin from handle control rod. Slide rod out of lever at lock mechanism.

6. Remove actuator lever pin and lock button rod clip. See Figure 22.

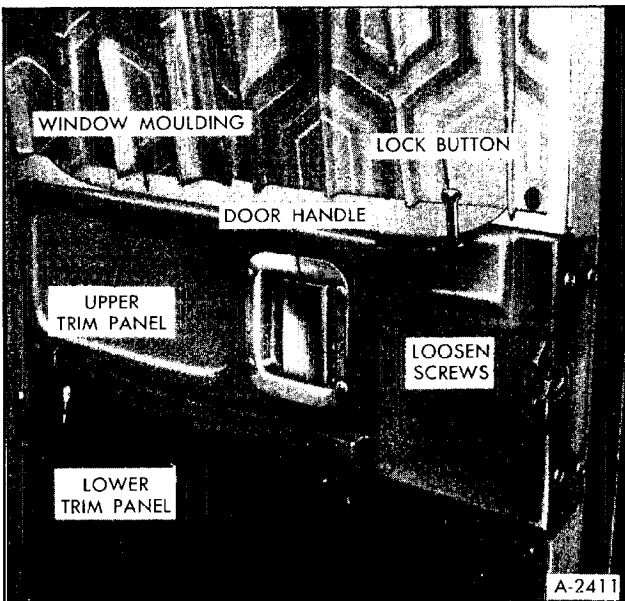

Figure 21--Removing Trim Panels

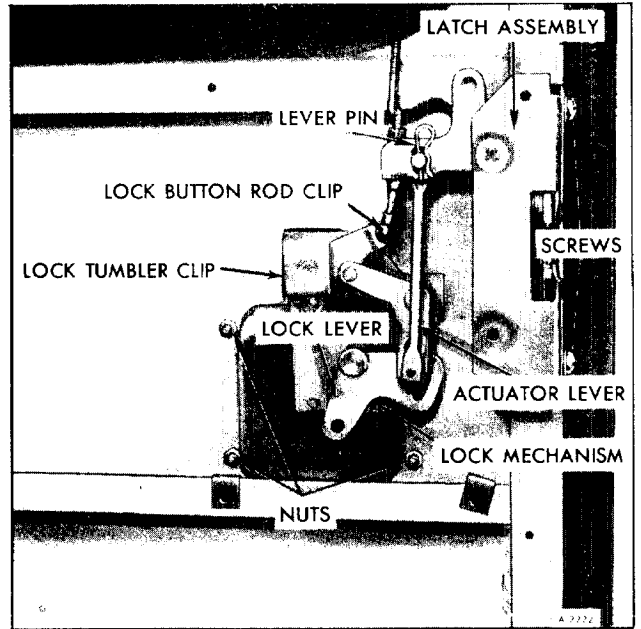

Figure 22--Lock Assembly

7. Remove (2) screws from latch assembly at door frame. Remove this portion from the door.

8. Remove four (4) nuts and lock tumbler clip. Remove lock mechanism. See Figure 22.

### INSTALLATION - TYPE III

1. Check sealer around lock opening in door, replace or fill in as required to insure proper seal between lock assembly and door.

2. Apply a liberal amount of lubriplate to all contacting surfaces. Secure assembly with four (4) nuts.

3. Install lock tumbler and secure with clip.

4. Install latch assembly on door frame and loosely secure with two (2) screws on door frame.

5. Install lock button rod clip and actuator lever pin as shown in Figure 22.

6. Install inner panel and handle assembly. At the same time guide handle rod into lever at lock mechanism.

7. Install cotter pin to secure rod to lever.

8. Secure upper trim panel with screws.

9. Install lower door trim panel and window moulding.

## DOOR HINGES

### REMOVAL

1. Remove entrance door. Refer to "Door-Removal" earlier in this section.

2. Remove two (2) bolts per hinge.

3. Remove hinge.

### INSTALLATION

1. Install hinge on door frame and two (2) bolts. Torque to 25-30 ft. lbs.

2. Install entrance door. Refer to "Door-Installation" earlier in this section.

## ACCESS DOORS

### FRONT ACCESS DOOR LATCH REPLACEMENT

#### REMOVAL

1. Drill out rivets (2) on each side of handle. See Figure 23.

2. Remove "T" pin. See Figure 23.

3. Slide latch mechanism out of door.

#### INSTALLATION

1. Position latch mechanism in access door.

2. Install pop rivets.

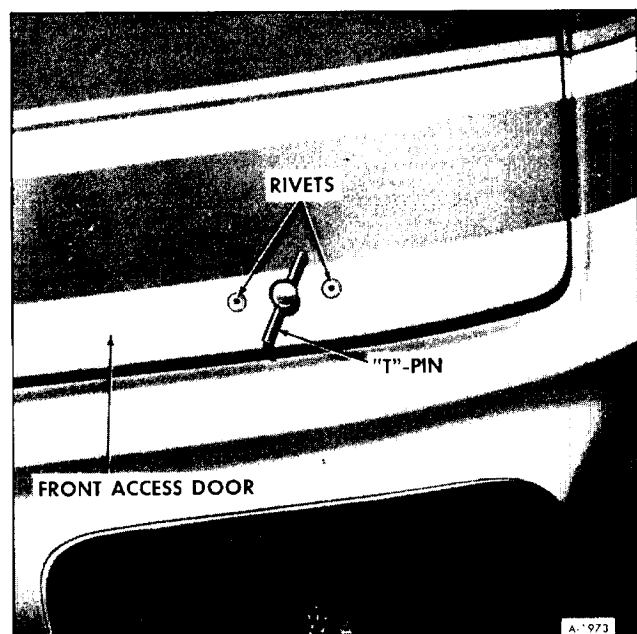

Figure 23-Front Access Door Latch

3. Install "T" pin.

### FRONT ACCESS DOOR REPLACEMENT

#### REMOVAL

1. On outboard side of door remove two nuts and bolts retaining support to door.

2. Remove nuts and bolts retaining hinge to body.

3. Remove access door.

#### INSTALLATION

1. Position access door in body opening and install hinge retaining nuts and bolts to body.

2. Position access door support to access door and secure with nut and bolt.

### EXTERNAL UTILITIES COMPARTMENT DOOR REPLACEMENT

#### REMOVAL

1. Drill out four pop-rivets holding piano hinge to body (See figure 24).

2. Remove door. Door may be removed from hinge by drilling out four pop-rivets retaining door to hinge.

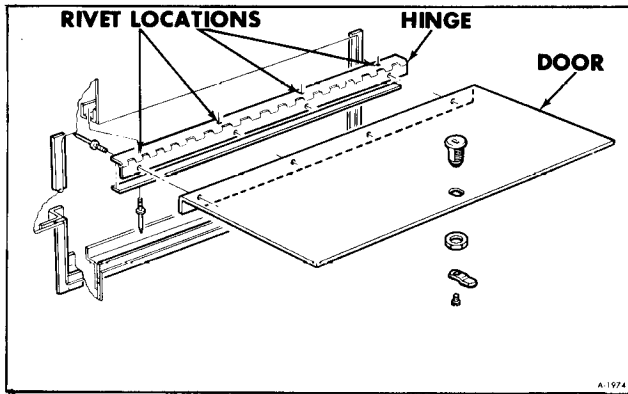

Figure 24-External Utilities Compartment Door

## INSTALLATION

Position door and hinge assembly in its opening and pop-rivet door in place.

## LP GAS, OR STORAGE DOOR REPLACEMENT

Both LP gas door and the storage (or motor generator) door are removed and installed in the same manner.

## REMOVAL

1. With the access door closed drill out pop rivets that retain the hinge to the body.
2. Unfasten latches and remove door.

## INSTALLATION

1. Position door in its opening.
2. Pop rivet hinge to body.

## LAP BELT MAINTENANCE

Keep belts clean and dry. Clean periodically with a mild soap solution and lukewarm water. Keep sharp edges and damaging objects away from belts. Periodically inspect belts, buckles, retractors, and anchors for damage that could materially lessen the effectiveness of the belt installation and repair or

replace the questionable parts. Do not bleach or dye belts as this may cause severe loss of strength.

If necessary, to replace belts or related attaching parts be sure to tighten lap belt anchor bolts to 35-45 foot-pounds torque.

## FLOOR

### GENERAL INFORMATION

The floor of the vehicle is made of 1 inch plywood sections. The plywood is treated with a wood preservative. The plywood sections are pop-riveted to the extruded aluminum supports as shown in Figure 25. The floor sections can be replaced but repair is more practical and is covered later in this section.

The engine cover, the only section designed to be removed, is located between the driver and passenger seat and is secured by a lip in the front and two screw attachments at each rear corner.

The wheel houses are made of plastic polyethylene. The front housings are repairable or replaceable if damaged. The rear housing are repairable if damaged. The entire underfloor area has been sprayed with a rust preventative and sealer coating.

### FRONT WHEEL HOUSINGS

#### REMOVAL

1. Remove six (6) screws securing housing to fiberglass wheel opening.
2. Remove one (1) bolt securing housing to floor support.
3. Remove wheel housing.

#### INSTALLATION

1. Install and position wheel housing.
2. Install one (1) bolt securing housing to floor support.



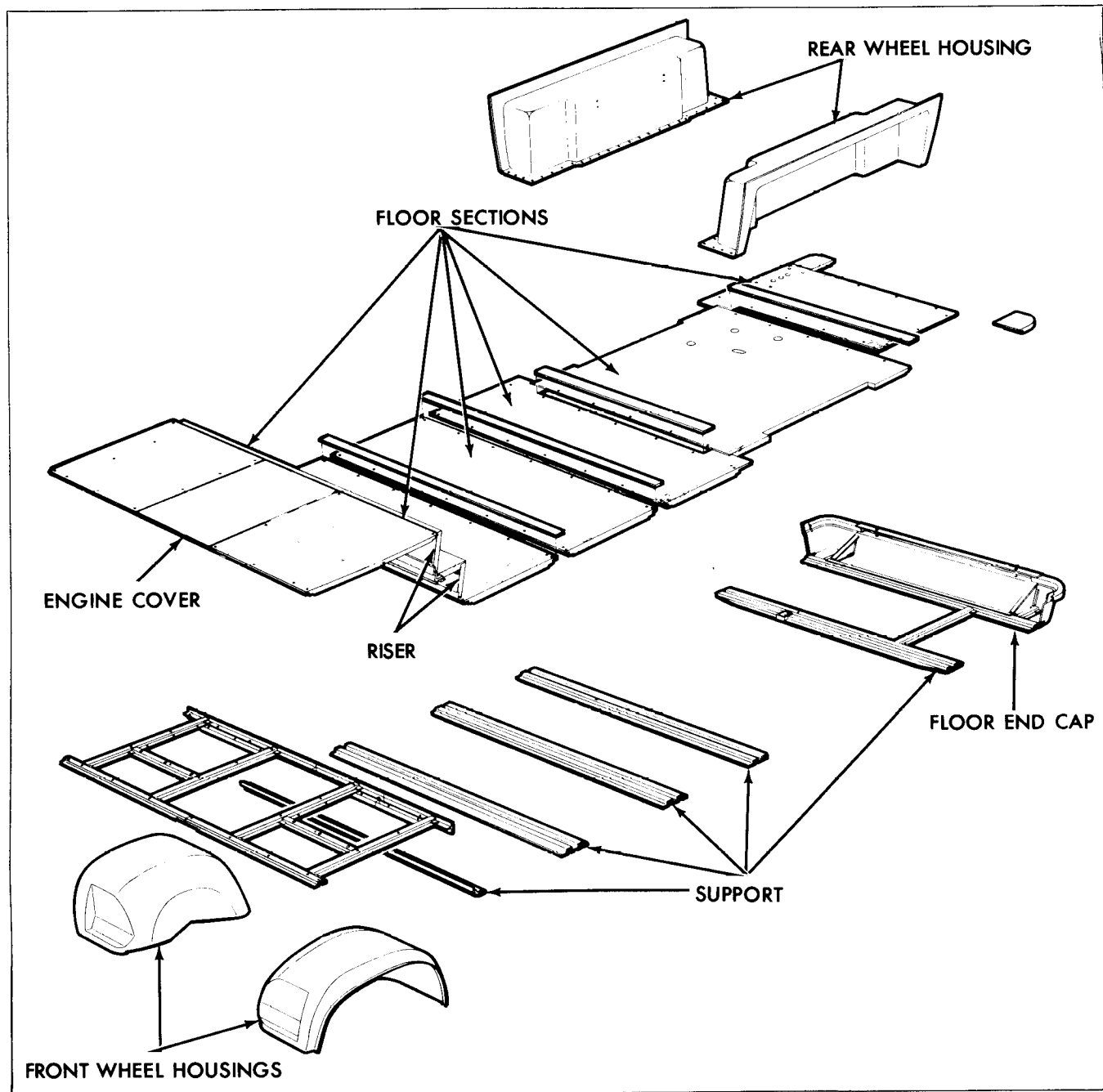

Figure 25—Wheel Housings and Floor (Model 260 Shown)

3. Install six (6) screws to secure housing to fiberglass wheel opening.

## PLYWOOD FLOOR

**CAUTION:** *Before drilling, sawing, chiseling etc. the plywood be sure damage will not occur to components directly under the floor.*

A thorough inspection of the damaged floor area should be made before attempting any repair. The damaged area should be replaced with one inch exterior grade plywood. One inch plywood will not only provide proper strength but it also, has an insulation rating equal to the insulation applied to the sides and roof of the vehicle. It is not necessary to replace an entire section but this will depend on the location and the extent of the damage.

All sections are secured to the supports with pop-rivets. Any pop-rivet may be removed by drilling

into the center of the rivet with a 3/16" drill bit. Drill approximately 1/8" deep and with a punch tap into this hole to drive the rivet shaft out.

**CAUTION:** *Care must be taken to properly seal any seams or joints resulting from floor section replacement or repair. Exhaust gases, dust, water etc. will leak past any seam or joint not caulked.*

The underside surfaces of new plywood must be coated with a wood preservative.

## ENGINE COVER

This removable floor section is made of one inch plywood. A seal is secured to the underside of the cover with an adhesive and staples. A damaged gasket should be replaced using a suitable adhesive and staples.

The rear corners of the cover are secured by screwing the bolt into a clip nut mounted to the cover frame. Proper operation of this fastener is important to allow the cover seal to make good contact with the frame.

Fasteners are replaceable and are held in place with two wood screws. Peel back the carpeting from the corner as required to gain access to wood screws. The clip nut is a standard hardware item and is replaceable.

If the fastener is replaced apply some adhesive to the cover to hold the carpet in place at the corners.

## REAR WHEEL HOUSINGS

All wheel houses as previously mentioned are constructed of plastic (polyethylene). Also, mentioned in "Front Wheel Housing-Removal" was the fact only the front wheel houses are replaceable besides being repairable. The rear wheel houses are repairable.

Any repair to the wheel houses will have to be with cover patches secured by fasteners. The chemical composition of polyethylene resists standard plastic adhesives. The suggested repair is to cut out a patch to cover the damaged area. Black polyethylene will make the best patch but sheet metal or sheet aluminum may be used. Hold the patch in place and mark the patch in places (1 1/2" to 2" apart) to be drilled. Remove the patch and select the proper drill bit. Drill holes in the patch. Place patch back on wheel house and mark wheel house in places to be drilled. Drill holes in wheel house being very careful not to drill any deeper than required to penetrate the 1/5" thick wheel house.

Apply a liberal amount of caulking on the patch. Position patch on wheel house and use pop-rivets to secure the patch to wheel house.

If sheet metal or sheet aluminum were used the patch area may be painted black.

## REPAIR OF FIBERGLASS COMPONENTS

Before starting repair operations, look for hidden damage by applying force around the damaged area, looking for hairline cracks and other breakage. Early repair of minor damage may prevent major repair later.

### PRECAUTIONS

Creams are available to protect the skin from a condition known as occupational, or contact dermatitis. Improved resin formulas have almost eliminated skin irritation. Cream is available for persons who may have a tendency toward skin irritation from the resins or dust.

The application of these creams is recommended whenever the resin materials are used. Generally the cream is not required when the plastic (epoxy) solder kit is being used.

1. Remove resin mixture from hands as soon as possible and always before mixture starts to gel. This can be observed by the action of the material being used. Resin may be removed with lacquer thinner by washing in soap and water.

2. Respirators are recommended when grinding. Also, some minor skin irritation from glass and powdered cured resin may be evident. Washing in cold water will help to minimize.

3. Use a sander with a vacuum attachment for dust control whenever possible.

4. Resin mixtures may produce toxic fumes and should be used in well ventilated areas.

5. Be careful not to get any resin material on clothing.

6. Use the proper materials for the job.

7. Keep materials, utensils and work area clean and dry. These repairs involve chemical reactions, and dirt or moisture may upset the chemical balances and produce unsatisfactory results.

## REPAIR PROCEDURES

For repair procedures refer to General Motors Service Information Bulletin (B-4). Copies of the

fiberglass repair bulletin (B-4) may be ordered from the following address:

General Motors Service Information

P.O. Box 7124

Detroit, Michigan, 48202

Materials, for repairing damaged fiberglass panels, are available in kit form through GM Dealerships, or equivalent kits can be purchased locally.

## SHEET METAL REPAIR

The aluminum panels on the body may be repaired if damaged. Filler putty can be used for minor dents, scratches, scraps etc. However, major damage to a panel will require removal of at least part of the panel. Because the panels are secured to the ribs with a polyurethane adhesive, separating and removing panels is difficult. Any rivets used on the panels are easily removed by drilling off the rivet head and, using a punch, drive out the rivet shaft.

All windows, access doors, vents, belt and roof line trim mouldings in the damaged area should be removed before removing the panel.

An air chisel will be helpful to remove the panel. Operate the air chisel along the rib to break the adhesive bond between the panel and the rib.

**CAUTION:** *Be careful during chiseling, sawing, drilling etc. on the aluminum panels not to damage wiring, piping, insulation, components etc. which are located immediately behind the panels.*

Any damaged rib will have to be straightened, replaced or have shim material fastened to the rib so

proper support will be provided for the aluminum panel.

A replacement panel should be fitted after the ribs have been thoroughly cleaned of adhesive. A suggested method would be to grind off the adhesive with an extra coarse disc on an air driven grinding wheel.

With the ribs cleaned a new panel may be fitted into the opening. Next, with the panel in place drill holes, or use existing holes, (at each corner and along the belt line and roof line) through the panel and rib for using pop-rivets.

Remove panel and apply adhesive such as manufactured by Minnesota Mining and Manufacturing XB3529 or equivalent to the rib. Follow the manufacturers mixing and curing instructions. Position panel in place and pop-rivet using pre-drilled holes.

The adhesive will cure at room temperature in 24 hours. The rivet holes may be ground off and the holes filled with a body putty.

## SEATS

### DRIVER AND SINGLE PASSENGER SEAT

The seat assembly can be removed by itself or as a unit with pedestal assembly.

#### SEAT REMOVAL

1. Swivel chair to a 45° position.

2. This will allow access to the four retaining bolts. Remove four bolts (See figure 26).

3. Remove seat.

#### SEAT INSTALLATION

1. Swivel top of pedestal to allow access to seat mounting holes.

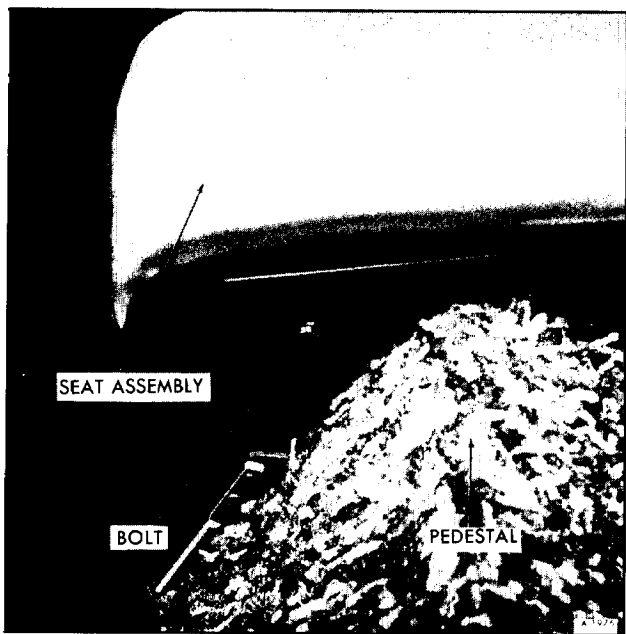

Figure 26—Seat Attaching Bolts

2. Position spacers and install retaining bolts to weld nuts in base of seat. Tighten securely.

## PEDESTAL REPLACEMENT

### REMOVAL

1. Remove seat as described above.

2. Remove nine nuts and bolts from base of pedestal. (Access to nuts can be made through the engine access cover)

3. Remove pedestal.

### INSTALLATION

1. Position pedestal over mounting holes.

2. Install nuts and bolts to retain pedestal.

3. Install seat as described previously in this section.

## DUAL PASSENGER SEAT REPLACEMENT

The dual passenger seat is removed in the same manner as the driver and single passenger seat, refer to the preceding procedures for removal and installation.

The pedestal for the dual passenger seat is also removed by the same method as the driver and single passenger seat pedestal.

## MIRRORS AND SUN VISOR

### INSIDE REAR VIEW MIRROR

#### REMOVAL

1. Loosen set screw at base of mirror.

2. Slide mirror to the rear and remove.

#### INSTALLATION

1. Position mirror on sun visor and mirror mounting bracket.

2. Tighten set screw.

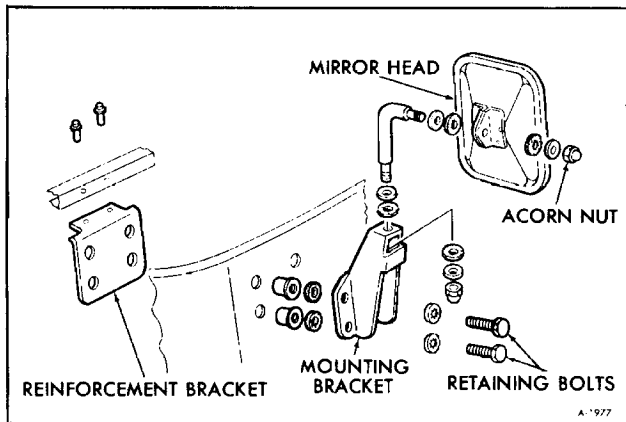

Figure 27—Exterior Mirror

### OUTSIDE REARVIEW MIRROR (FIGURE 27)

The entire mirror assembly can be removed by removing four retaining bolts from the mirror bracket. Install by replacing these four bolts.

Either the mirror head or support arm can be removed by removing the acorn nut as shown in Figure 27.

A reinforcement bracket is used to back the riv-nuts which retains the mirror assembly to the body. This bracket is held in place by two rivets to the sill.

## SUN VISOR

### REMOVAL

Remove visor from center support bracket, and

swing visor to side. Visor can now be removed by loosening hex head bolt at end of visor shaft.

### INSTALLATION

Position visor and install threaded end of visor arm into its mounting bracket. Tighten hex head bolt and position visor in support clip.

## RADIATOR GRILLE (FIGURE 28)

### REMOVAL

1. Open front access doors.
2. Remove six nuts from inside of grille.
3. Remove grille.

### INSTALLATION

1. Position grille with studs through body.
2. Install six nuts and washers to retain grille in proper position.

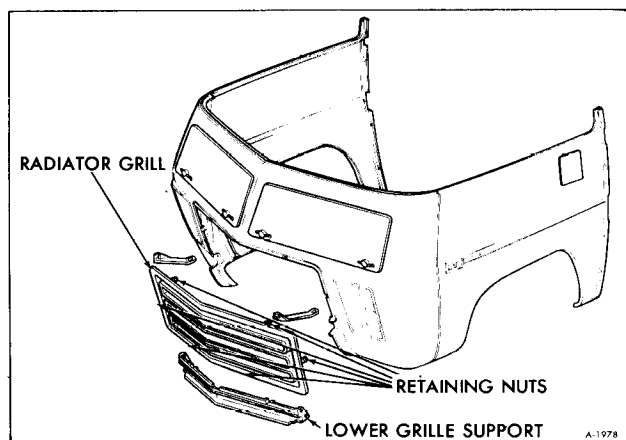

Figure 28—Radiator Grille

## END CAP

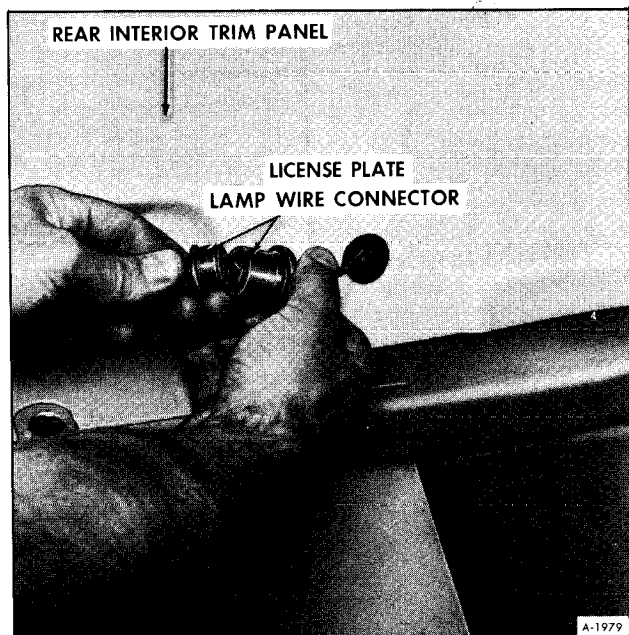

Figure 29—Disconnecting Wire to License Plate Lamp

### REMOVAL

1. Disconnect wires for license plate light at lower left-hand inside corner as shown in Figure 29.

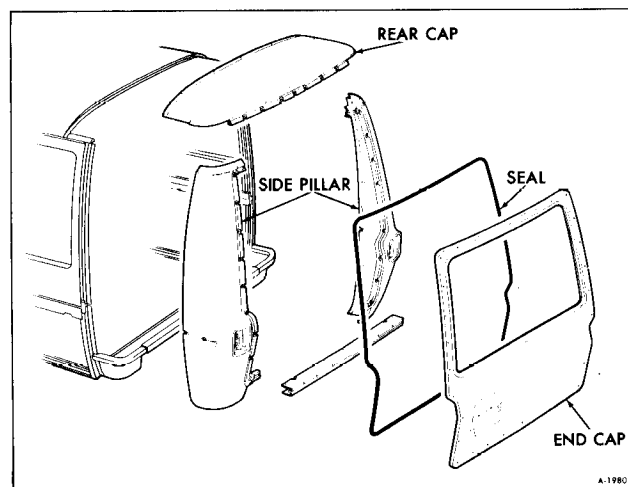

Figure 30—End Cap Components

**NOTE:** It may be necessary to remove interior trim at rear of Motor Home to gain access to license plate wiring connector.

2. Remove screws from interior trim to end cap.
3. Remove end cap to body retaining screws (32) from end cap (See figure 30).
4. Remove end cap from body.

## INSTALLATION

1. Check seal to make sure it is still intact. Replace seal, if necessary.
2. Position end cap in place and install 32 retaining screws.
3. Install screws retaining interior trim to end cap.
4. Reconnect license plate wiring.

## SPECIAL TOOLS

J-2189  
J-9316

Glass Seal and Insert Installer  
Windshield Alignment Blocks

# AIR CONDITIONING SYSTEM (INCLUDES HEATING)

Contents of this section are listed below:

SUBJECT	PAGE NO.
General Description.....	1-23
System Components and Their Function.....	1-31
General Information .....	1-44
Inspection and Periodic Service .....	1-49
Evacuating and Charging Procedures .....	1-49
Refrigerant Quick Check Procedure.....	1-54
Maintenance and Adjustments .....	1-54
General Repair Procedures and Component Replacement.....	1-56
Compressor Minor Overhaul Procedures.....	1-64
Compressor Major Overhaul Procedures .....	1-68
Leak Testing the Compressor .....	1-78
Air Conditioning Diagnosis .....	1-78
Vacuum Control Charts .....	1-85
Special Tools .....	1-85

## GENERAL DESCRIPTION

Both the heating and cooling functions are performed by this system. Air entering the vehicle must pass through the cooling unit (evaporator) and through (or around) the heating unit, in that order, and the system is thus referred to as a "reheat" system.

The evaporator provides maximum cooling of the air passing through the core when the air conditioning system is calling for cooling. A thermostatic switch, located in the blower-evaporator case, acts to control compressor operation by sensing the fin temperature of the evaporator core.

System operation is as follows: Air, either outside air or recirculated air, enters the system and is forced through the system by the blower. As the air passes through the evaporator core, it receives maximum cooling if the air conditioning controls are calling for cooling. After leaving the evaporator, the air enters the Heater and Air Conditioner Selector Duct Assembly where, by means of diverter doors, it is caused to pass through or to bypass the heater core in the proportions necessary to provide the desired outlet temperature. Conditioned air then enters the vehicle through the dash outlets. When, during cooling operations, the air is cooled by the evaporator to below comfort level, it is then warmed by the heater to the desired temperature. During "heating only" operations, the compressor will not be in operation and ambient air will be warmed to the desired level in the same manner.

The dash outlets are rectangular in design and have two-way action. The whole outlet can be swiveled and the inside louvers can be turned to direct air as desired. Also there are two floor outlets.

## THEORY OF OPERATION

### HEAT

We all know what air conditioning does for use but very few understand how or why it works. An air conditioner is functionally very similar to a refrigerator. A refrigerator is a simple mechanism which, surprisingly enough, works quite a bit like a teakettle boiling on a stove. That may sound far-fetched, but there is more similarity between the two than most of us would suspect. A modern refrigerator can make ice cubes and keep food cool and fresh only because a liquid called the refrigerant boils inside the freezer.

Everyone knows a boiling teakettle is "hot" and a refrigerator is "cold". We usually think of "cold" as a definite, positive condition. The only way we can define it is in a rather negative sort of way by saying "cold" is simply the lack of heat, just as darkness is the lack of light. We can't make things cold directly. All we can do is remove some of the heat they contain and they will become cold as a result. And that is the main job of any refrigerator. Both are simply devices for removing heat.

### Transfer of Heat

The only thing that will attract heat is a colder object. Like water, which always flows downhill, heat always flows down a temperature scale - from a warm level down to a colder one. When we hold our hands out toward the fireplace, heat flows from the hot fire out to our cold hands (figure 1). When

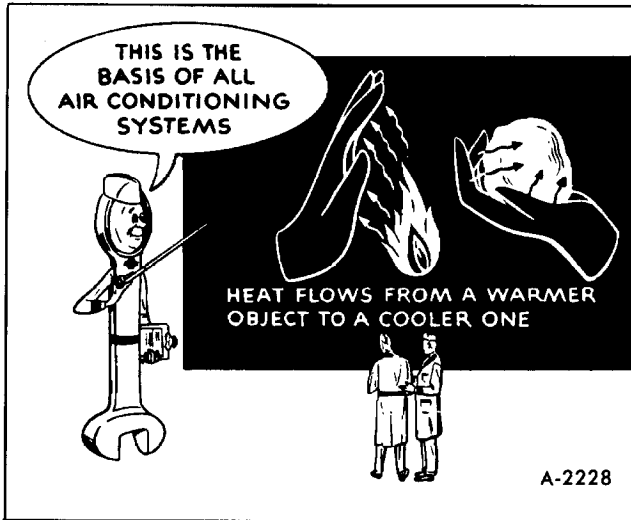

Figure 1-Heat Transfer

we make a snowball, heat always flows from our warm hands to the colder snow.

**Measurement of Heat**

Everyone thinks he knows how heat is measured. Thermometers are used in every home. (Whenever we speak of temperature from now on, we will mean Fahrenheit). They can tell how hot a substance is, but they can't tell us everything about heat.

When we put a teakettle on a stove, we expect it to get hotter and hotter until it finally boils. All during the process, we can tell exactly how hot the water is by means of a thermometer (figure 2). Our thermometer will show us that the flame is just as hot when we first put the teakettle on the stove as it is when the water finally boils. Why doesn't the water boil immediately? Why does it take longer to boil a

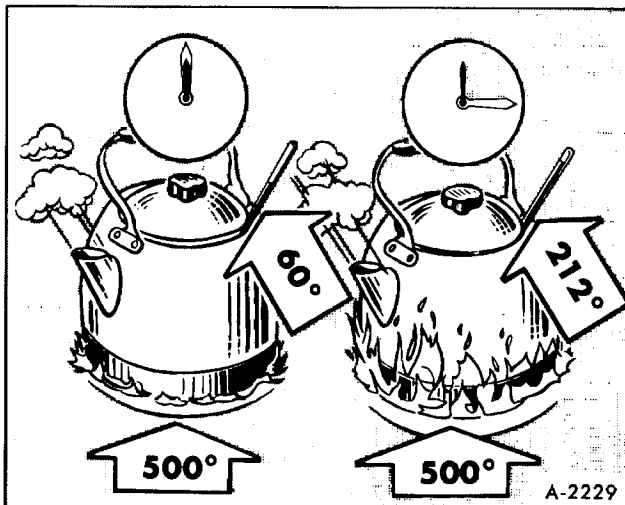

Figure 2-Measurement of Heat

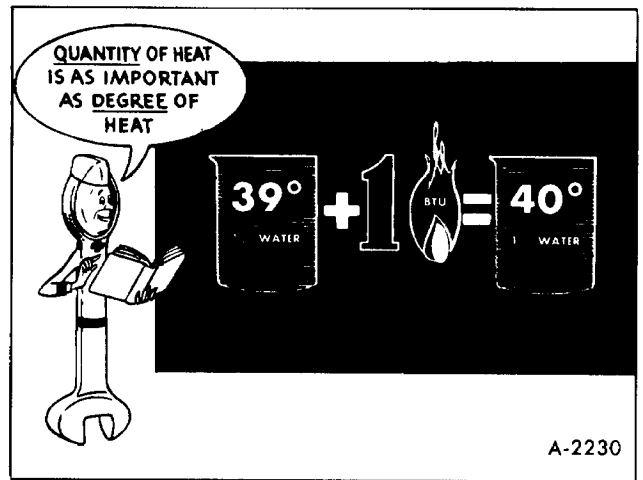

Figure 3-Quantity of Heat

quart of water than a cupful? Obviously temperature isn't the only measurement of heat.

Even though heat is intangible, it can be measured by quantity as well as intensity. Thermometers indicate only the intensity of heat. The unit for measuring quantity of heat is specified as that amount necessary to make 1 pound of water 1 degree warmer (figure 3). We call this quantity of heat a British Thermal Unit. Oftentimes, it is abbreviated to B.T.U.

Perhaps we can get a better idea of these two characteristics of heat if we think of heat if we think of heat as a sort of coloring dye. If we add one drop of red dye to a glass of water, it will turn slightly pink. Another drop will make the water more reddish in color. The more drops of dye we add, the redder the water will get. Each drop of dye corresponds to 1 B.T.U. and the succeeding deeper shades of red are like increases in temperature.

It may seem a little puzzling to talk about heat in a manual on air conditioning...but, when you stop to think about it, we are handling heat exclusively. Although we ordinarily think of an air conditioner as a device for making air cold, it does that indirectly. What it does is to take heat away from the air and transfer that heat outside the vehicle.

We know now that cold is nothing more than the absence of heat, and that heat always flows from a warm object to a colder one. We also have a clearer idea of how heat is measured.

From everything we've learned about heat so far, it seems to behave in a perfectly normal manner. Yet sometimes heat will disappear without leaving a single clue.



## Ice vs Water For Cooling

Every once in a while in the old days, the iceman would forget to stop by to refill the icebox. Occasionally, as the last sliver of ice melted away, somebody would come up with a bright idea. He would remember that the water in the drainpan always felt iccold when he emptied it other times. So, he would get the thermometer out and check its temperature. Sure enough, it usually was about as cold as the ice. Why not put the drainpan back in the ice compartment to keep things cold until the iceman returned the next day?

For some strange reason, the icebox never stayed cold. The drain water soon got quite warm and in a couple of hours, the butter in the icebox would begin to melt, the milk would start to sour, and the vegetables would wilt.

The drain water was only a few degrees warmer than the ice yet it didn't draw nearly as much heat out of the stored foods. The difference between the behavior of cold drain water and ice is the real secret as to how any refrigerator works, and we can easily see this by using an ordinary thermometer.

When we put a drainpan full of cold water into the ice compartment, we expect the heat to flow from the warm foods to the colder water. Remember, that heat always flows from a warm object to a colder object and when we add heat to water, it gets warmer. Each B.T.U. of heat added to a pound of water makes it one degree warmer.

If we were to put a thermometer in the cold drain water, we would see the temperature gradually creep upwards. That is to be expected because heat is flowing into the cold water making it warmer. Before long the water would be as warm as the stored foods. Then the water could no longer attract heat because heat will not flow from one warm object to another equally warm object. Since we no longer can draw heat out of the foods we no longer are cooling them.

Now, let's see what happens when we put ice instead of cold water into the icebox. This time, we'll set the thermometer on top of the ice (figure 4). When we first look at the thermometer, it reads 32°. A couple of hours later, the ice chunk is smaller because some of the ice has already melted away – but the thermometer still reads 32°.

All this time, the ice has been soaking up heat, yet it never gets any warmer no matter how much heat it draws from the stored food. On the other hand, the cold drain water got progressively warmer as it soaked up heat. The addition of heat will make water warmer yet won't raise the temperature of ice above the 32° mark.

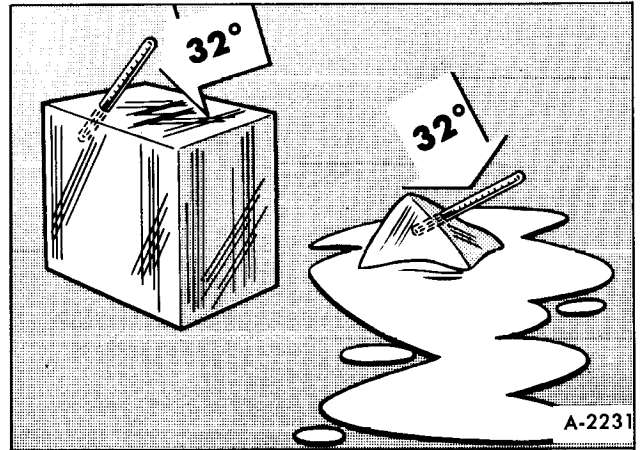

Figure 4—Melting Ice Remains at 32°

If we fill one drinking glass with ice and another with cold water, and put both glasses in the same room where they could absorb equal amounts of heat from the room air, we will find it takes much, much longer for the ice to melt and reach room temperature than it did for the water in the other glass to reach the same temperature. Obviously, most of the heat was being used to melt the ice. But it was the heat that apparently disappeared or was transformed because it couldn't be located with a thermometer. To describe this disappearing heat scientists chose the word "latent" which means hidden.

### Latent Heat

So latent heat is nothing more or less than hidden heat which can't be found with a thermometer.

At first it was thought that latent heat was in the water that melted from the ice. But that wasn't exactly the right answer because, upon checking water temperature as it melts from ice, it will be found that it is only a shade warmer than the ice itself. It is not nearly warm enough to account for all the heat the ice had absorbed. The only possible answer is that the latent heat had been used up to change the ice from a solid into a liquid.

Many substances can be either a solid, or a liquid, or a gas. It just depends on the temperature whether water for example was a liquid, or a solid (ice), or gas (steam) (figure 5).

All solids soak up huge amounts of heat without getting any warmer when they change into liquids, and the same thing will happen when a substance changes from a liquid into a gas.

Put some water in a teakettle, set it over a fire and watch the thermometer as the water gets hotter and hotter, the mercury will keep rising until the water

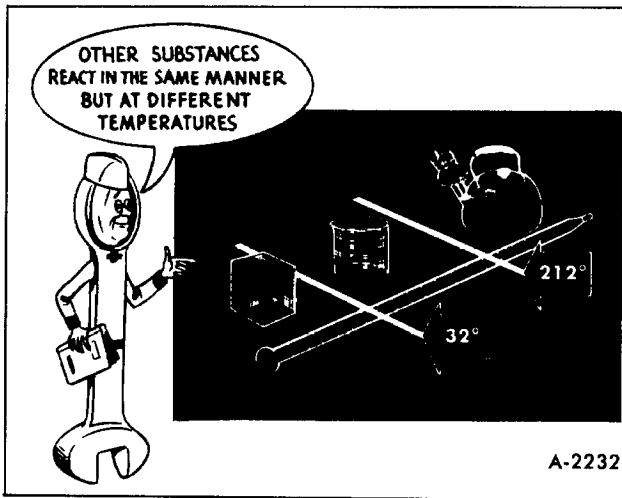

Figure 5—Temperature Determines the State of Water

starts to boil. Then the mercury seems to stick at the 212° mark. Put more wood on the fire, despite all the increased heat, the mercury will not budge above the 212° mark (figure 6).

No matter how large or hot you make the flame, you can't make water any hotter than 212° at sea level. As a liquid changes into a gas, it absorbs abnormally great amounts of heat without getting any hotter.

Now we have two different kinds of latent heat, which are quite a bit alike. To keep their identities separate, the first one is called **latent heat of fusion**, which means the same as melting. The other kind is called **latent heat of vaporization** because that means the same as evaporation.

### Refrigeration

It may seem as though we have discussed heat instead of refrigeration. But in doing so, we have

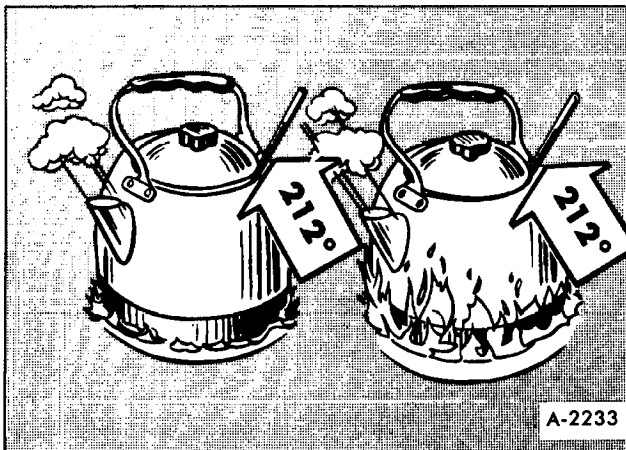

Figure 6—Boiling Water Never Exceeds 212° at Sea Level

learned how a simple icebox works. It's because the latent heat of fusion gives ice the ability to soak up quantities of heat without getting any warmer. Since it stays cold, it can continue to draw heat away from stored foods and make them cooler.

The latent heat of vaporization can be even better because it will soak up even more heat.

Whenever we think of anything boiling, we think of it being pretty hot, but that's not true in every case. Just because water boils at 212° doesn't mean that all other substances will boil at the same temperature. Some would have to be put into a blast furnace to make them bubble and give off vapor. On the other hand, others will boil violently while sitting on a cake of ice.

And so each substance has its own particular boiling point temperature. But regardless of whether it is high or low, they all absorb unusually large quantities of heat without getting any warmer when change from a liquid into a vapor.

Consequently, any liquid that will boil at a temperature below the freezing point of water, will make ice cubes and keep vegetables cool in a mechanical refrigerator.

## REFRIGERANTS

The substance that carries heat out of a refrigerator cabinet is the refrigerant.

There are many refrigerants known to man. In fact, any liquid that can boil at temperatures somewhere near the freezing point of water can be used.

But a boiling point below the temperature at which ice forms is not the only thing that makes a good refrigerant. A refrigerant should also be non-poisonous and non-explosive to be safe. Besides that, we want a refrigerant that is non-corrosive and one that will mix with oil.

Chemists tried to improve existing natural refrigerants. But after exploring along that line, they still hadn't succeeded. They started from scratch and juggled molecules around to make an entirely new refrigerant. Eventually they succeeded by remodeling the molecules in carbon tetrachloride. This is the same fluid that was used in fire extinguishers and dry-cleaners' solvents.

From this fluid, the chemists removed two chlorine atoms and replaced them with two fluorine atoms. This newly formed fluid carried the technical chemical name of dichlorodifluoromethane. Today,

it is sold commercially by manufacturers as Refrigerant-12 or R-12. Non-tox, non-inflammable, non-explosive, and non-poisonous, however, breathing large quantities of R-12 should be avoided.

**Refrigerant-12**

Refrigerant-12, which we use in Air Conditioning Systems, boils at 21.7° below zero. Picture a flask of R-12 sitting on the North Pole boiling away just like a teakettle on a stove. No one would dare pick up the flask with his bare hands because, even though boiling, it would be so cold and it would be drawing heat away from nearby objects so fast that human flesh would freeze in a very short time.

If we were to put a flask of R-12 inside a refrigerator cabinet, it would boil and draw heat away from everything surrounding it (figure 7). So long as any refrigerant remained in the flask, it would keep on soaking up heat until the temperature got clear down to 21.7° below zero.

Now we can begin to see the similarity between a boiling teakettle and a refrigerator. Ordinarily we think of the flame pushing heat into the teakettle. Yet, it is just as logical to turn our thinking around and picture the teakettle pulling heat out of the flame. Both the teakettle and the flask of refrigerant do the same thing – they both draw in heat to boil although they do so at different temperature levels.

There also is another similarity between the icebox and the mechanical refrigerator. In the icebox, water from melting ice literally carried heat out of the cabinet. In our simple refrigerator, rising vapors do the same job.

**Reusing R-12**

R-12, or any other refrigerant, is too expensive

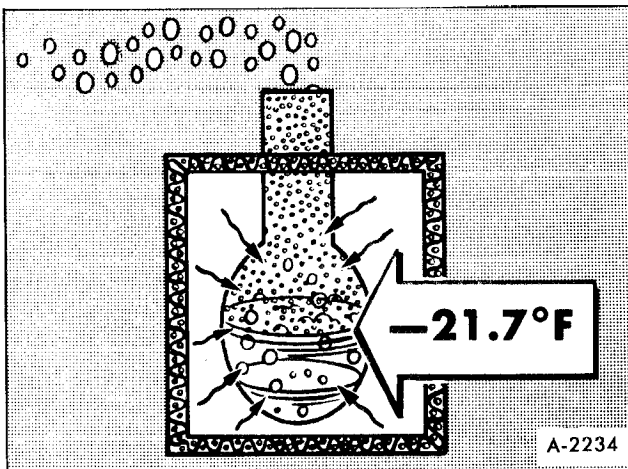

Figure 7-A Simple R-12 Refrigerator

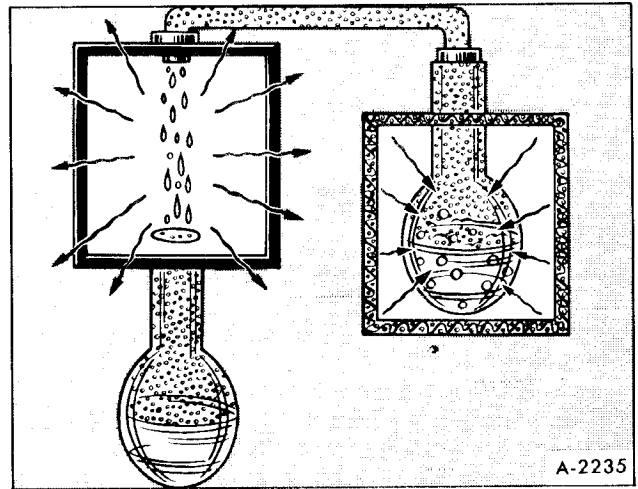

Figure 8- Reusing Refrigerant

just to let float away into the Atmosphere. If there was some way to remove the heat from the vapor and change it back into a liquid, it could be returned to the flask and used over again (figure 8).

That is where we find the biggest difference between the old icebox and the modern refrigerator. We used to put in new ice to replace that lost by melting. Now we use the same refrigerant over and over again.

We can change a vapor back into a liquid by chilling it, or do the same thing with pressure. When we condense a vapor we will find that the heat removed just exactly equals the amount of heat that was necessary to make the substance vaporize in the first place.

This is called the latent heat of vaporization - the heat that apparently disappeared when a liquid boiled into a vapor – again reappears - when that same vapor reverts back into a liquid. It is just like putting air into a balloon to expand it and then letting the same amount of air out again to return the balloon to its original condition.

We know that any substance will condense at the same temperature at which it boiled. This temperature point is a clear-cut division like a fence. On one side, a substance is a liquid. Immediately on the other side it is a vapor. Whichever way a substance would go, from hot to cold or cold to hot, it will change its character the moment it crosses over the fence.

Water will boil at 212° under normal conditions. Naturally, we expect steam to condense at the same temperature. But whenever we put pressure on steam, it doesn't. It will condense at some temperature higher than 212°. The greater the pressure, the higher the boiling point and the temperature at

which a vapor will condense. This is the reason why pressure cookers cook food faster, since the pressure on the water permits it to boil out at a higher temperature.

We know that R-12 boils at 21.7° below zero. A thermometer will show us that the rising vapors, even though they have soaked up lots of heat, are only slightly warmer. But the vapors must be made warmer than the room air if we expect heat to flow out of them. The condensing point temperature must be above that of room air or else the vapors won't condense.

This is where pressure helps, with pressure, we can compress the vapor, thereby concentrating the heat it contains. When we concentrate heat in a vapor that way, we increase the intensity of the heat or, we increase the temperature, because temperature is merely a measurement of heat intensity (figure 9).

**Pressure in Refrigeration**

Because we must use pressures and gauges in air conditioning service, the following points are mentioned so that we will all be talking about the same thing when we speak of pressures.

All pressure, regardless of how it is produced, is measured in pounds per square inch (psi).

Atmospheric Pressure is pressure exerted in every direction by the weight of the atmosphere. At sea level atmospheric pressure is 14.7 psi. At higher altitudes air has less weight (lower psi).

Any pressure less than atmospheric (14.7) is known as a partial vacuum or commonly called a vacuum. A perfect vacuum or region of no pressure has never been mechanically produced.

Gauge pressure is used in refrigeration work. Gauges are calibrated in pounds (psi) of pressure and inches of Mercury for vacuum. At sea level, "0" lbs. gauge pressure is equivalent to 14.7 lbs. atmospheric pressure. Pressure greater than atmospheric is measured in pounds (psi) and pressure below atmospheric is measured in inches of vacuum. The "0" on the gauge will always correspond to the surrounding atmospheric pressure, regardless of the elevation where the gauge is being used.

**Pressure-Temperature Relationships of R-12**

A definite pressure and temperature relationship exists in the case of liquid refrigerants and their saturated vapors. Increasing the temperature of a substance causes it to expand. When the substance is confined in a closed container, the increase in temperature will be accompanied by an increase in pressure, even though no mechanical device was used. For every temperature, there will be a corresponding pressure within the container of refrigerant. A table of the temperature-pressure relationship of R-12 is presented below. Pressures are indicated in gauge pressure, either positive pressure (above atmospheric) in pounds or negative pressure (below atmospheric) in inches of vacuum.

Thus if a gauge is attached to a container of R-12 and the room temperature is 70°, the gauge will register approximately 70 psi pressure; in a 100° room, the pressure would be 117 psi.

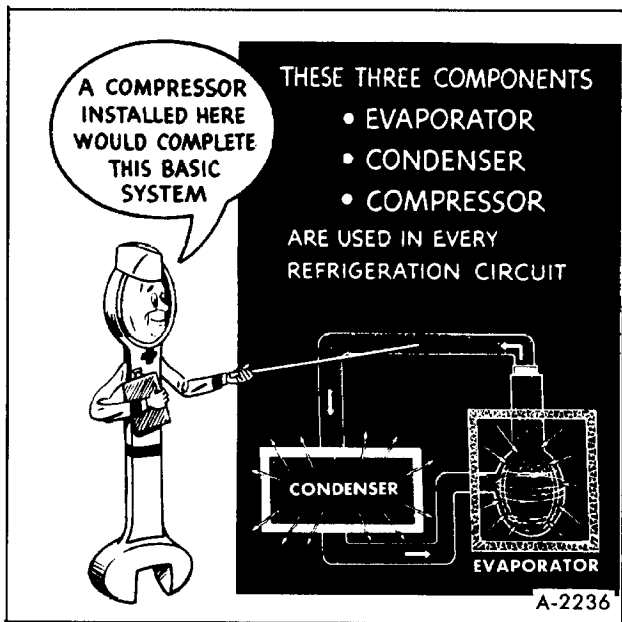

Figure 9—Basic Refrigerant Circuit

°F	Pressure (psi)	°F	Pressure (psi)
-40	11.0*	+50	46.7
-35	8.3*	+55	52.0
-30	5.5*	+60	57.7
-25	2.3*	+65	63.7
-20	0.6	+70	70.1
-15	2.4	+75	76.9
-10	4.5	+80	84.1
-5	6.8	+85	91.7
0	9.2	+90	99.6
+5	11.8	+95	108.1
+10	14.7	+100	116.9
+15	17.7	+105	126.2
+20	21.1	+110	136.0
+25	24.6	+115	146.5
+30	28.5	+120	157.1
+32	30.1	+125	167.5
+35	32.6	+130	179.0
+40	37.0	+140	204.5
+45	41.7	+150	232.0

\* Inches of Vacuum

## Pressure and Flow

When we use a tire pump to inflate an automobile tire, we are creating pressure only because we are “pushing” against the air already entrapped inside the tire. If a tire has a puncture in it, you could pump all day, and still not be able to build up any pressure. As fast as you would pump the air in, it would leak out through the puncture. Unless you have something to push against – to block the flow of air – you can’t create more than a mere semblance of pressure.

The same situation holds true in an air conditioning system. The compressor can pump refrigerant vapor through the system, but unless it has something to push against, it cannot build up pressure. All the compressor would be doing would be to circulate the vapor without increasing its pressure.

We can’t just block the flow through the system entirely. All we want to do is put pressure on the refrigerant vapor so it will condense at normal temperatures. This must be done sometime after the vapor leaves the evaporator and before it returns again as a liquid. High pressure in the evaporator would slow down the boiling of the refrigerant and penalize the refrigerating effect.

## Controlling Pressure and Flow

Pressure and flow can be controlled with a float valve, or with a pressure-regulating valve.

The float valve type will give us a better idea of pressure and flow control, let’s look at it first.

It consists simply of a float that rides on the surface of the liquid refrigerant. As the refrigerant liquid boils and passes off as a vapor, naturally the liquid level drops lower and lower. Correspondingly, the float, because it rides on the surface of the refrigerant, also drops lower and lower as the liquid goes down.

By means of a simple system of mechanical linkage, the downward movement of the float opens a valve to let refrigerant in. The incoming liquid raises the fluid level and, of course, the float rides up along with it. When the surface level of the refrigerant liquid reaches a desired height, the float will have risen far enough to close the valve and stop the flow of refrigerant liquid.

We have described the float and valve action as being in a sort of definite wide open or tight shut condition. Actually, the liquid level falls rather slowly as the refrigerant boils away. The float goes down gradually and gradually opens the valve just a crack. At such a slow rate of flow, it raises the liquid level in the evaporator very slowly.

It is easy to see how it would be possible for a stabilized condition to exist. By that, we mean a condition wherein the valve would be opened enough to allow just exactly the right amount of refrigerant liquid to enter the system to take the place of that leaving as a vapor.

## Refrigerator Operation

We’ve now covered all the scientific ground-rules that apply to refrigeration. Try to remember these main points. All liquids soak up lots of heat without getting any warmer when they boil into a vapor, and, we can use pressure to make the vapor condense back into a liquid so it can be used over again. With just that amount of scientific knowledge, here is how we can build a refrigerator.

We can place a flask of refrigerant in an icebox. We know it will boil at a very cold temperature and will draw heat away from everything inside the cabinet (figure 9).

We can pipe the rising vapors outside the cabinet and thus provide a way for carrying the heat out. Once we get the heat-laden vapor outside, we can compress it with a pump. With enough pressure, we can squeeze the heat out of “cold” vapor even in a warm room. An ordinary radiator will help us get rid of heat.

By removing the heat, and making the refrigerant into a liquid, it becomes the same as it was before. So, we can run another pipe back into the cabinet and return the refrigerant to the flask to be used over again.

That is the way most mechanical refrigerators work today. Now, let’s look at air conditioning to see the benefits of air conditioning and how an air conditioner works.

## AIR CONDITIONING

Because air-conditioning has always been very closely allied with mechanical refrigeration, most of us are apt to think of it only as a process for cooling room air.

Air Conditioning goes beyond the mere cooling of the air. It controls the humidity, cleanliness and circulation of the air.

Whenever it gets warm and muggy in the summertime, someone is almost sure to say, “It’s not the heat...it’s the humidity.” But that is only partly right. Actually it is a combination of the two that makes us

feel so warm...temperature alone is not the only thing that makes us uncomfortable.

Humidity is the moisture content of the air. To a certain extent, it is tied in with the temperature of the air. Warm air will hold more moisture than will cold air. When air contains all the moisture it can hold, it is saturated, and the relative humidity is 100%. If the air contains only half as much water as it could hold at any given temperature, we say that the relative humidity is 50%. If it contains only a fifth of its maximum capacity, we say that the relative humidity is 20%. This amount of water vapor, or relative humidity, affects the way we perspire on hot days.

Nature has equipped our bodies with a network of sweat glands that carry perspiration to the skin surfaces. Normally, this perspiration evaporates and absorbs heat just like a refrigerant absorbs heat when it is vaporized in a freezer. Most of the heat is drawn from our bodies, giving us a sensation of coolness. A drop of alcohol on the back of your hand will demonstrate this principle convincingly. Alcohol is highly volatile, and will evaporate very rapidly and absorb quite a bit of heat in doing so, making the spot on your hand feel cool.

The ease and rapidity with which evaporation takes place, whether it be alcohol or perspiration, governs our sensation of coolness and to a certain extent, independently of the temperature. The ease and rapidity of the evaporation are directly affected by the relative humidity or comparative dampness of the air. When the air is dry, perspiration will evaporate quite readily. But when the air contains a lot of moisture, perspiration will evaporate more slowly; consequently less heat is carried away from our body.

From the standpoint of comfort, air-conditioning should control the relative humidity of the air as well as its temperature.

By reducing the humidity, we oftentimes can be just as "cool" in a higher room temperature than otherwise would be comfortable. Laboratory tests have shown that the average person will feel just as cool in a temperature of 79° when the relative humidity is down around 30% as he will in a cooler temperature of 72° with a high relative humidity of 90%.

There are practical limits though within which we must stay when it comes to juggling humidity. For comfort, we can't go much below a relative humidity of 30% because anything lower than that would cause an unpleasant and unhealthy dryness in the throat and nasal passages.

Summertime temperatures of 85° sometimes bring with them relative humidities around 75% to

80%. To gain maximum human comfort, an air conditioning system should cool the air down and reduce the humidity to comfortable limits.

Along with the cooling job it does, the evaporator unit also removes much of the moisture from the air. Everyone is familiar with the sight of thick frost on the freezer of a refrigerator. That frost is simply frozen moisture that has come out of the air.

The evaporator unit as an air conditioning system does the same thing with this one exception. Because its temperature is above the freezing point, the moisture remains fluid and drips off the chilling unit. A further advantage of air conditioning is that dust and pollen particles are trapped by the wet surfaces of the evaporator core and then drained off along with the condensed moisture. This provides very clean, pure air for breathing.

### BASIC AIR CONDITIONER

When we look at an air conditioning unit, we will always find a set of coils or a finned radiator core through which the air to be cooled passes. This is known as the "evaporator". It does the same job as the flask of refrigerant we spoke about previously. The refrigerant boils in the evaporator. In boiling, of course, the refrigerant absorbs heat and changes into a vapor. By piping this vapor outside the vehicle we can bodily carry out the heat that caused its creation.

Once we get vapor out of the evaporator, all we have to do is remove the heat it contains. Since heat is the only thing that expanded the refrigerant from a liquid to a vapor in the first place, removal of that same heat will let the vapor condense into a liquid again. Then we can return the liquid refrigerant to the evaporator to be used over again.

Actually, the vapor coming out of the evaporator is very cold. We know the liquid refrigerant boils at temperatures considerably below freezing and that the vapors arising from it are only a shade warmer even though they do contain quantities of heat. Consequently, we can't expect to remove heat from sub-freezing vapors by "cooling" them in air temperatures that usually range between 60° and 100°...heat refuses to flow from a cold object toward a warmer object.

But with a pump, we can squeeze the heat-laden vapor into a smaller space. And, when we compress the vapor, we also concentrate the heat it contains. In this way, we can make the vapor hotter without adding any heat. Then we can cool it in comparatively warm air.

That is the only responsibility of a compressor in an air conditioning system. It is not intended to be a pump just for circulating the refrigerant. Rather, its job is to exert pressure for two reasons. Pressure makes the vapor hot enough to cool off in warm air. At the same time, the compressor raises the refrigerant's pressure above the condensing point at the temperature of the surrounding air so it will condense.

As the refrigerant leaves the compressor, it is still a vapor although it is now quite hot and ready to give up the heat that it absorbed in the evaporator. One of the easiest ways to help refrigerant vapor discharge its heat is to send it through a radiator-like component known as a condenser.

The condenser really is a very simple device having no moving parts. It does exactly the same job as the familiar radiator in a typical home steam-heating

system. There, the steam is nothing more than water vapor. In passing through the radiator, the steam gives up its heat and condenses back into water.

The purpose of the condenser, as the name implies, is to condense the high pressure, high temperature refrigerant vapor discharged by the compressor into a high pressure liquid refrigerant. This occurs when the high pressure, high temperature refrigerant is subjected to the considerably cooler metal surfaces of the condenser. This is due to the fundamental laws, covered earlier, which state that "heat travels from the warmer to the cooler surface," and that "when heat is removed from vapor, liquid is produced."

When the refrigerant condenses into a liquid, it again is ready for boiling in the evaporator. So, we run a pipe from the condenser back to the evaporator.

## SYSTEM COMPONENTS AND THEIR FUNCTIONS

The air conditioning system used on the GMC Motor Home utilizes components in the following categories:

1. The Refrigeration Components
2. The Electrical Components
3. The Vacuum Components

It is important that the operation of these components be fully understood in order to properly diagnose and repair air conditioning problems.

### REFRIGERATION COMPONENTS

The refrigeration components are those which come in contact with and effect or are effected by the Refrigerant-12. They move it, cool it, warm it and regulate it.

### COMPRESSOR

The prime purpose of the compressor (figure 10) is to take the low pressure refrigerant vapor produced by the evaporator and compress it into a high pressure, high temperature vapor which will be sent on to the condenser.

It utilizes the principle that "when a vapor is compressed, both its pressure and temperature are raised" which we have already discussed. The com-

pressor is mounted above the engine in a special mounted bracket and is belt driven from the engine through an electro-magnetic clutch pulley on the compressor.

The compressor has three double-acting pistons, making it a six cylinder compressor. The compressor has a 1.5 inch bore and 1.1875 inch stroke, giving it a total displacement of 12.6 cu. in. Identification of the compressor is by model and serial number stamped on a plate on top of the compressor.

#### Clutch-Pulley

The movable part of the clutch drive plate is in front of the pulley and bearing assembly. The armature plate, the movable member, is attached to the drive hub through driver springs and is riveted to both members. The hub of the drive plate is pressed over a square drive key located in the compressor shaft. A spacer and retainer ring are assembled to the shaft and the assembly is held in place with a self-locking nut. The pulley rim, power element ring and pulley hub are formed into a final assembly by molding a frictional material between the rim and the hub with the power element ring imbedded in the forward face of the assembly.

A two-row ball bearing is pressed into the pulley hub and held in place by a retainer ring. The entire pulley and bearing assembly is then pressed over the front head of the compressor and secured by a retainer ring.

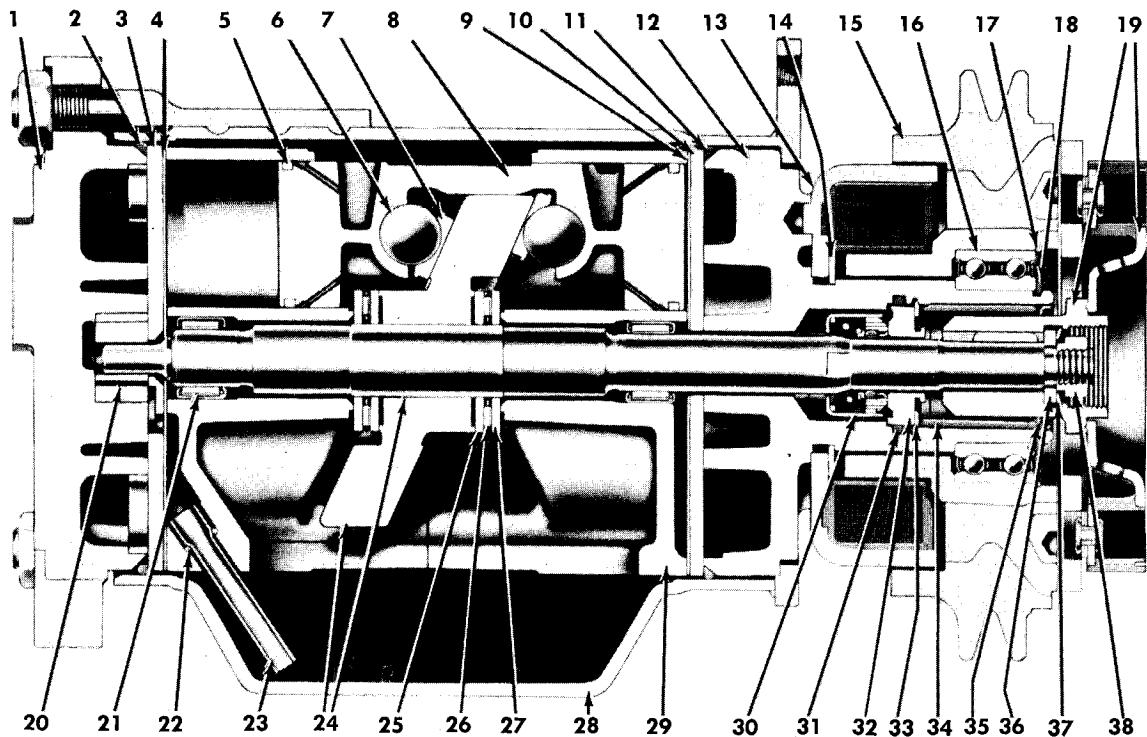

- |  |  |
|--|--|
| 1 Rear Head                            | 20 Oil Pump Gears                      |
| 2 Rear Head to Shell O-ring            | 21 Mainshaft Bearing (Rear)            |
| 3 Rear Discharge Valve Plate           | 22 Oil Inlet Tube O-ring               |
| 4 Rear Suction Reed Plate              | 23 Oil Inlet Tube                      |
| 5 Piston Ring                          | 24 Wobble Plate and Mainshaft Assembly |
| 6 Piston Drive Ball                    | 25 Thrust Race                         |
| 7 Ball Seat                            | 26 Thrust Bearing                      |
| 8 Piston                               | 27 Thrust Race                         |
| 9 Front Suction Reed Plate             | 28 Compressor Shell                    |
| 10 Front Discharge Valve Plate         | 29 Cylinder Assembly                   |
| 11 Front Head to Shell O-ring          | 30 Shaft Seal                          |
| 12 Front Head                          | 31 Shaft Seal Seat O-ring              |
| 13 Coil and Housing Assembly           | 32 Shaft Seal Seat                     |
| 14 Coil Housing Retainer Ring          | 33 Shaft Seal Seat Retainer Ring       |
| 15 Pulley and Bearing Assembly         | 34 Felt Sleeve                         |
| 16 Pulley Bearing                      | 35 Felt Sleeve Retainer                |
| 17 Pulley Bearing Retainer Ring        | 36 Spacer                              |
| 18 Pulley and Bearing Retainer Ring    | 37 Clutch Hub Retainer Ring            |
| 19 Clutch Hub and Drive Plate Assembly | 38 Shaft Nut                           |

T-4175

Figure 10-Compressor Cross Sectional View

### Clutch Coil

The coil is molded into the coil housing with a filled epoxy resin and must be replaced as a complete assembly. Three protrusions on the rear of the housing fit into alignment holes in the compressor front head. A retainer ring secures the coil and housing in place. The coil has 3.85 ohms resistance at 80°F. ambient temperature and will require no more than

3.2 amperes at 12 volts D.C. Since the clutch coil is not grounded internally, a ground lead is required as well as a "hot" lead. This will be discussed in greater detail in the Electrical Component discussion in this section.

### Shaft Seal

The main shaft seal, located in the neck of the



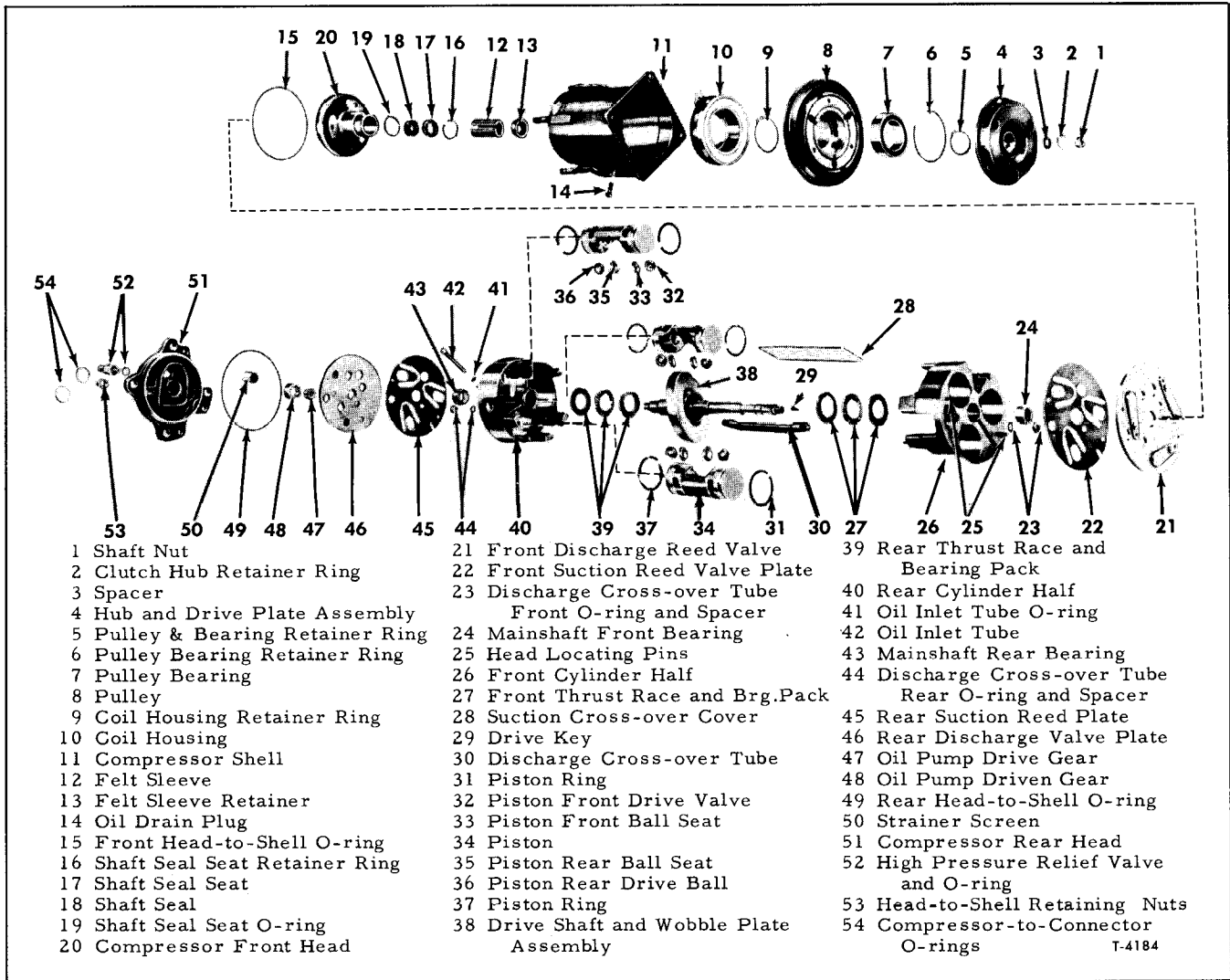

Figure 11-Compressor Exploded View

compressor front head, consists of the seal assembly with its ceramic seal face in a spring loaded cage. An "O" ring seal, located within the ceramic seal, provides a seal to the shaft surface. The contact surface of the shaft seal seat is finished to a high polish and must be protected against nicks, scratches and even fingerprints. Any surface damage will cause a poor seal. An "O" ring, located in an internal groove in the neck of the front head provides a seal with the outer diameter of the seal seat. A retainer ring, tapered side away from the seat, secures the seat in place. The hub and armature plate must be removed to gain access to the seal. A shaft seal kit contains all necessary replacement parts for field service.

After removing the clutch drive, pulley-bearing and coil housing assemblies, the rear head and internal mechanism (figure 10) may be removed from the compressor shell. Four threaded studs, welded to the compressor shell, locate the rear head and four lock nuts secure it in place.

### Rear Head

The rear head (figure 11) has a machined cavity in the center for the oil pump gears. This cavity, in all compressors, is machined so that the eccentricity of the bore is approximately .042 inch to the LEFT of the centerline of the cavity. The counterclockwise rotation compressor used in some other systems has the eccentricity machined approximately .042 inch to the RIGHT of the cavity centerline. A small diameter hole is drilled in the head between the two. The unit number is stamped on a plate attached to the counterclockwise rotation head and a decal arrow indicates the direction of rotation.

### Mainshaft

The central mainshaft, driven by the clutch-pulley when the coil is energized, extends through the front head to the rear head and oil pump cavity of

the compressor. The shaft revolves in needle roller bearings located in the front and rear halves of the cylinder assembly. 3/16" internally drilled passage extends through the shaft from the rear oil pump cavity to the shaft seal cavity in the front compressor head. Four .078 inch holes, drilled at 90° to the main passage, direct oil under pump pressure to the shaft seal surfaces, thrust bearings and shaft-cylinder bearings.

### Wobble Plate

The wobble plate is an angular shaped member pressed onto the mainshaft forming the mainshaft and wobble plate assembly (figure 11). A woodruff key prevents movement of the plate around the shaft. Location of the plate on the shaft is factory set and must not be changed. The very smooth angular faces of the plate are ground to be parallel within .0003 inches of each other. The plate changes the rotating action of the shaft into the reciprocating driving force for three pistons. The driving force is applied, through the drive balls and ball seats (shoe discs) to the midpoint of each of the double end pistons.

### Cylinder Block

The cylinder block consists of a front and a rear half. Three piston bores are line bored in each half during production to assure proper alignment and parallelism. The two halves must be serviced as an assembly to assure correct relationship of parts.

### Pistons

The cast aluminum double end pistons (figure 11), have grooves to receive piston rings. Each ring has an oil scraper groove which should face away from the piston face. Two oil return passages are drilled from each ring groove. A notch in the casting web of each piston identifies the end of the piston which should be positioned toward the front end of the compressor. A spherical cavity is located on both inner faces of each piston to receive the piston drive balls.

### Drive Balls

The hardened steel drive balls have a micro-finish. They are manufactured to a .0001 inch spherical tolerance and a .6248 - .6250 inch diameter tolerance.

### Ball Seats

The bronze ball seats have one flat side, which contacts the wobble plate, and one concave surface into which the drive ball fits. Ten seats are provided

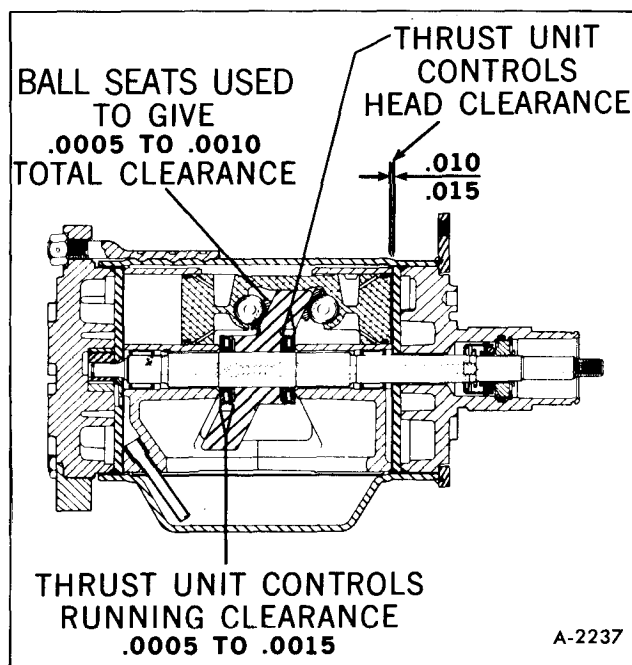

Figure 12—General Running Clearances

in .0005 inch thickness variations including a basic ZERO seat for simple field gauging operations. Seats are marked with their size which corresponds to the last three digits of the piece part number.

Selection from this group must be made to provide .0005 inch to .0010 inch total clearance between the ball seats and the wobble plate at the tightest place throughout its 360° rotation (figure 12).

### Thrust Bearings

The thrust bearings, sandwiched between two thrust races (see below) are located between the shoulders of the wobble plate and the shoulders of both the front and rear cylinder hubs.

### Thrust Races

The steel thrust races are ground to fixed thicknesses. A total of 14 races in increments of .0005 inch thickness are available for field service. As in the case of the ball seats the thrust races will be identified on the part by their thickness, the number on the race corresponding to the last three digits of the piece part number. The FRONT combination of a race, bearing and race is selected to provide the proper head clearance between the top of the cylinder and the underside of the suction and discharge valve plates. The REAR end combination of bearing and races is selected to obtain .0005 inch low limit to .0015 inch high limit running clearance between the hub surfaces of the wobble plate and the front and rear hubs

of the cylinder (figure 12). This allows .001 inch tolerance between the high and low limits.

### Oil Pump Gears

The oil pump gears are made of sintered iron. The inner, or driver gear has a "D" shaped hole in the center which fits over a similar area on the rear of the mainshaft.

### Shell

The compressor shell has a mounting flange on the front end and four threaded studs welded to the outside of the rear end. The oil sump is formed into the shell and a baffle plate is welded over the sump on the inside of the shell.

### Heads

Both front and rear heads have an irregular shaped casting web. These webs provide the necessary seals to the surfaces of the discharge plates and prevent high pressure vapor from flowing into the low pressure cavity.

### Suction Screen

A fine mesh inlet (or suction) screen is located in the low pressure cavity of the rear head. Its purpose is to stop any material which could damage the compressor mechanism.

### Suction Cross-Over Cover

The suction cross-over cover, with its neoprene seal is pressed into the dove-tail cavity in the front and rear cylinder castings to form a passage for the low pressure vapor to flow the rear head of the compressor to the front head.

### Discharge Cross-Over Tube

Since the double acting pistons supply high pressure vapor at both ends of the compressor the discharge tube is needed to supply a path for the high pressure vapor to pass from the front to the rear head. Should the cylinder halves be separated during service operations a service type discharge tube must be substituted.

### Suction Reed Valves

A separate three-reed suction valve disc is assembled to both front and rear heads. These reeds open when the piston is on the intake portion of the stroke to allow the low pressure vapor to flow into the

cylinder. When the piston reverses and begins the compression portion of its stroke the reed valves close against their seats, thus preventing the high pressure vapor from being forced back into the low side of the system.

### Discharge Valves

The two discharge valve plate assemblies act to direct high pressure vapor into the head castings. When the piston reverses into its suction stroke the high pressure on the opposite side of the plate causes the reeds to close thus maintaining the differential of pressure between high and low pressure areas. The discharge plates include the valves and the retainers which prevent the high pressure from distorting the valves during the pressure stroke of the piston.

### Head to Shell Seals

Two large diameter "O" rings internally seal the front and rear heads to the shell. A chamfered edge on the head castings creates a squeezing action between the discharge valve plates, the compressor, and the inside surface of the shell.

### Compressor Connector

Compressor connectors, are attached to the compressor rear head by means of a single bolt and lock washer. All have inlet and outlet connections connected by a strap to form an integral unit.

### Pressure Relief Valve

The pressure relief valve, located on the compressor rear head, is simply a safety valve designed to open automatically if the system pressure should reach a predetermined level high enough to cause system damage. After the pressure drops to a safe level the valve will close. After such an occurrence, the system should be thoroughly checked to discover and correct the cause of the abnormal pressure increase, and then should be purged, evacuated and charged.

## REFRIGERANT LINES

Special refrigerant hose lines are required to carry the refrigerant liquid and vapor between the various system components. The hose line with the smallest diameter is called the high pressure liquid line. It is routed from the condenser or receiver-dehydrator to the evaporator or thermostatic expansion valve. The large diameter hose line connecting

the compressor and evaporator is the low pressure vapor line. The large diameter hose between the compressor and condenser is the high pressure vapor discharge line.

These hoses are constructed with a synthetic material core covered with a woven metal mesh which is, in turn, covered by a woven fabric and coated for extra protection. This hose is so constructed to withstand the extreme pressures and temperatures found in the modern refrigeration system. **None but special refrigerant type hoses should be used.**

All systems make use of swaged type connections (hose to metal fittings) with metal to metal fittings being made using "O" rings. Care must be taken when making these connections that they not be turned down too tightly or damage to the "O" rings may result.

Flexible refrigerant hoses should not be permitted to contact the hot engine manifold nor should they be bent into a radius of less than 10 times their diameter.

## FAN SLIP CLUTCH

A special engine fan is used. It is a seven bladed fan, limited by means of a viscous clutch to a maximum speed of 3200 rpm, regardless of the speed of the engine. The silicone fluid in the clutch transmits only enough torque to drive the fan at this limited speed, thus avoiding excessive noise and power consumption by the fan at higher engine speeds. A temperature modulating device further limits fan speed to 1000 rpm until ambient temperature at the modulating device reaches 140°F. at which time fan speed will be allowed to increase to 3200 rpm. Some adjustment of the modulating device is possible.

## CONDENSER

The condenser receives the high pressure, high temperature gas which is pumped from the compressor and condenses it into a high pressure high temperature liquid. The heated gas which enters near the top of the condenser is cooled by giving off heat to the metal surfaces of the condenser. The heat is then extracted from these metal surfaces by the ram air passing over the condenser.

The condenser is located in front of the engine cooling system radiator so that it receives a high volume of air from the movement of the vehicle and from the engine fan.

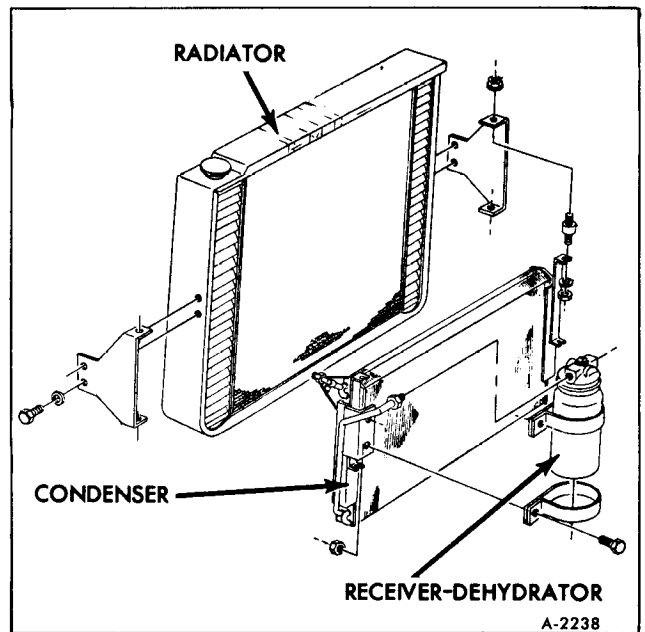

Figure 13—Condenser and Receiver-Dehydrator

The condenser is similar in design to the ordinary radiator but is designed to withstand much higher pressures (figure 13).

## RECEIVER-DEHYDRATOR

The receiver-dehydrator (figure 13), sometimes called the receiver-drier or just drier, is so called because of its function of receiving liquid refrigerant from the condenser and, by means of a dehydrating agent, removes any water present from it. This chemical compound is called a desiccant. The desiccant is held in place in a felt bag in the drier. Average receiver-drier desiccants collect and hold about 50 drops of water. This may not seem like much until you realize that one drop of water can block the whole air conditioning system.

The drier also filter-traps any foreign matter which may have entered the system during assembly or during any service work. This is accomplished by means of a fine wire screen.

Still another function of the receiver dehydrator is to act as a reservoir to furnish a constant column of liquid refrigerant to the expansion valve at all times. Since the entering liquid refrigerant may have some gas in it, the tank acts as a separator. The gas will tend to rise and the liquid will drop to the bottom. This is why the pick-up tube extends to the bottom of the tank insuring gas free liquid R-12 to the expansion valve. The storage of the refrigerant is temporary, and is dependent on the demand placed on it by the expansion valve.

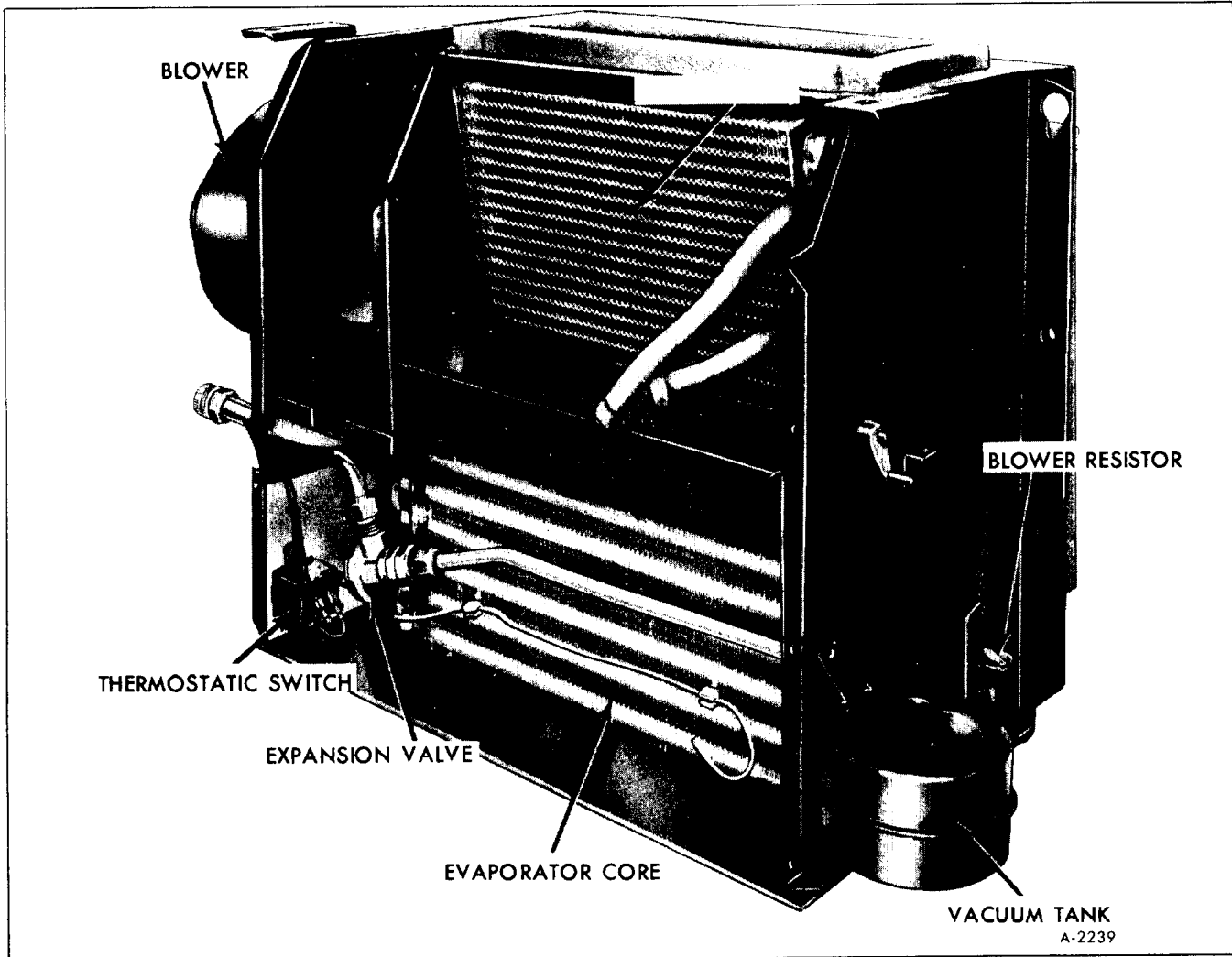

Figure 14—Evaporator Housing Components

While having no real function to perform in the system, the sight glass is a valuable aid in determining whether or not the refrigerant charge is sufficient and for eliminating some guess work in diagnosing difficulties. The sight glass, is built into the receiver-dehydrator outlet connection and is designed and located so that a shortage of refrigerant at this point will be indicated by the appearance of bubbles beneath the glass. The dust cap provided should be kept in place when the sight glass is not in use.

## THERMOSTATIC EXPANSION VALVE

The valve consists primarily of the power element, body, actuating pins, seat and orifice. At the high pressure liquid inlet, is a fine mesh screen which prevents dirt, filings or other foreign matter from entering the valve orifice.

The valve is located inside the evaporator housing (See figure 14).

When the valve is connected in the system, high pressure liquid refrigerant enters the valve through the screen from the receiver-dehydrator or condenser and passes on to the seat and orifice. Upon passing through the orifice the high pressure liquid becomes low pressure liquid. The low pressure liquid leaves the valve and flows into the evaporator core where it absorbs heat from the evaporator core and changes to a low pressure vapor, and leaves the evaporator core as such. The power element bulb is clamped to the low pressure vapor line just beyond the outlet of the evaporator (figure 15).

The operation of the valve is quite simple. It is a matter of controlling opposing forces produced by a spring and the refrigerant pressures. For example: The pressure in the power element is trying to push the seat away from the orifice, while the adjusting

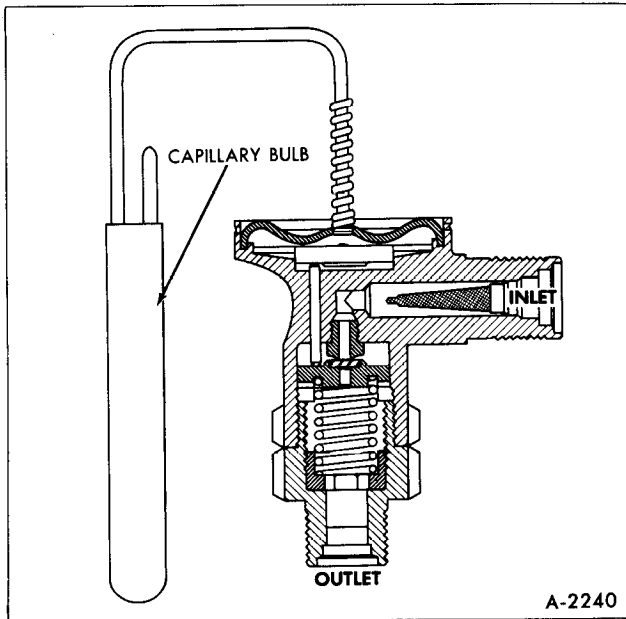

Figure 15—Expansion Valve Cross-Section

spring is trying to force the seat toward the orifice. These opposing pressures are established in the design of the valve so that during idle periods the adjusting spring tension and the refrigerant pressure in the cooling coil are always greater than the opposing pressure in the power element. Therefore, the valve remains closed. When the compressor is started, it will reduce the pressure and temperature of the refrigerant in the cooling coil to a point where the vapor pressure in the power element becomes the stronger. The seat then moves off the orifice and liquid starts to flow through the valve orifice into the cooling coil.

The purpose of the power element is to help determine the quantity of liquid that is being metered into the cooling coil. As the temperature of the low pressure line changes at the bulb, the pressure of the vapor in the power element changes, resulting in a change of the position of the seat. For example, if the cooling coil gets more liquid than is required, the temperature of the low pressure line is reduced and the resultant lowering of the bulb temperature reduces the pressure of the vapor in the power element, allowing the seat to move closer to the orifice. This immediately reduces the amount of liquid leaving the valve. Under normal operation, the power element provides accurate control of the quantity of refrigerant to the cooling coil.

To employ our tire pump analogy once more for clarity, it is the same situation that would exist if you were inflating a tire with a very slow leak. Providing you pumped the air into the tire as fast as it leaked out, you would be able to maintain pressure even

though the air would merely be circulating through the tire and leaking out through the puncture.

## EVAPORATOR

The function of the evaporator (figure 14) is to cool and dehumidify the air flow before it enters the passenger compartment. The evaporator assembly consists of an aluminum core enclosed in a sheet metal housing located in the front of the Motor Home chassis. Two water drain holes are located in the bottom of the housing. Two refrigerant lines are connected to the sides of the evaporator core: the small inlet line on the right, and the larger outlet line on the left.

The temperature sensing bulb of the expansion valve is clamped to the outlet pipe of the evaporator core. The high pressure liquid refrigerant, after it is metered through the expansion valve, passes into the evaporator core where it is allowed to expand under reduced pressure. As a result of the reduced pressure the refrigerant begins to expand and return to the original gaseous state. To accomplish this transformation it begins to boil.

The boiling action of the refrigerant demands heat. To satisfy the demand for heat, the air passing over the core gives up heat to the evaporator and is subsequently cooled.

## LOW REFRIGERANT CHARGE PROTECTION SYSTEM

The compressor discharge pressure switch (figure 16) performs the function of shutting off the compressor when it senses low refrigerant pressure. The switch is located in the evaporator inlet line (high pressure). The switch electrically is wired in series between the compressor clutch and the master switch on the control. When the switch senses low pressure it breaks contact and opens the circuit to the compressor clutch, thus shutting off the A/C system and preventing compressor failure or seizure.

The compressor discharge pressure switch also performs the function of the ambient switch as the pressure at the switch varies directly with ambient temperatures. The compressor should not run below 25°F. ambient or 37 psi at the switch. The compressor should run in A/C modes above 45°F. ambient or 42 psi at the switch.

The switch interacts with other switches so that in an A/C system where the compressor will not op-

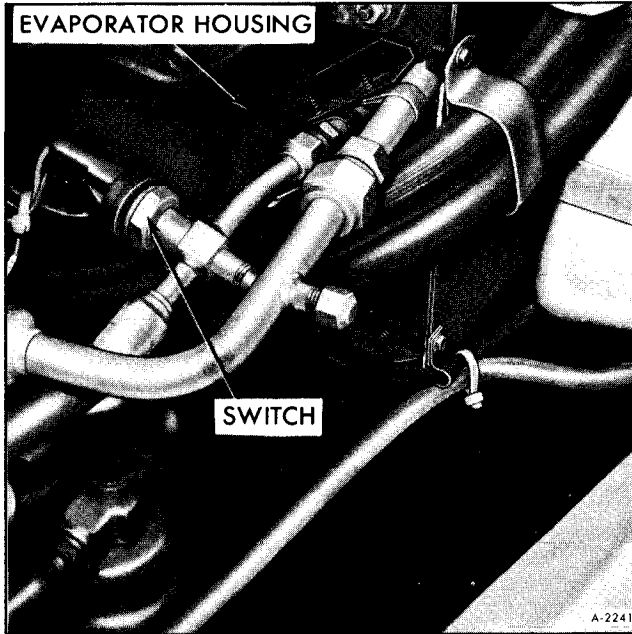

Figure 16-Compressor Discharge Pressure Switch

erate above 45° ambient the following components should be checked for continuity:

1. Compressor discharge pressure switch.
2. Master switch (on control head).

If both switches show proper continuity, check the harness for shorts or improper ground conditions. The switch also contains the high pressure line service ports.

## ELECTRICAL COMPONENTS

### COMPRESSOR CLUTCH ASSEMBLY

The clutch assembly (figure 10) consists of the coil, pulley and armature. The coil is basically an electro-magnetic device charged by the battery. When energized, it sends a magnetic force through the soft iron in the pulley, which is constantly turning as a result of being belt driven by the engine, to the armature. The armature is keyed to the compressor shaft. When magnetically energized the armature is pulled into the pulley causing the compressor to be activated.

### BLOWER

The blower (figure 17) is simply a device for moving air. The blower used in the GMC Motor Home

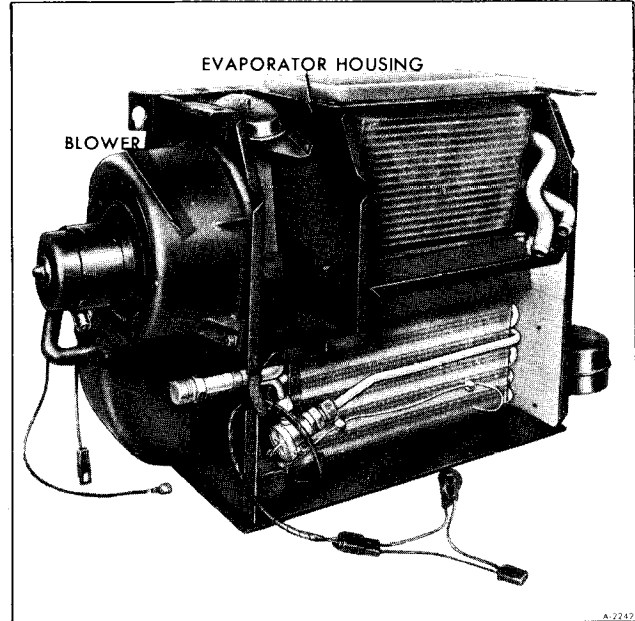

Figure 17-Blower Location

is a centrifugal type fan which forces air across the evaporator and/or heat cores to the vehicle interior.

### THERMOSTATIC SWITCH

The thermostatic switch (figure 14) is basically a bimetal switch which is controlled by a sensing tube across the outlet of the evaporator core. As the evaporator cools the sensing tube the bimetal switch turns off the clutch and disengages the compressor until the tube becomes warm enough to turn the compressor back on.

### BLOWER SWITCH, RELAY & RESISTOR

The blower switch, blower relay and the blower

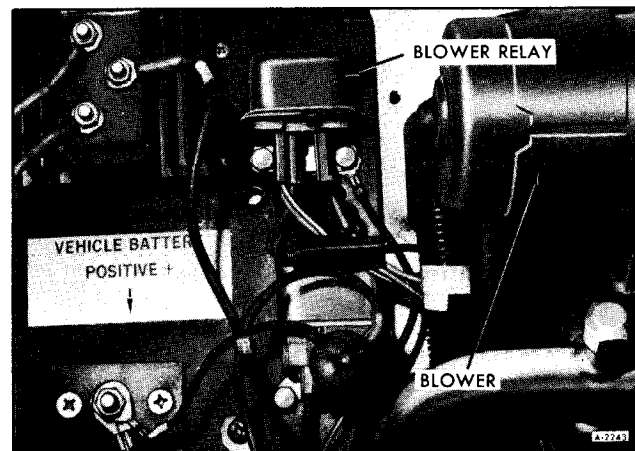
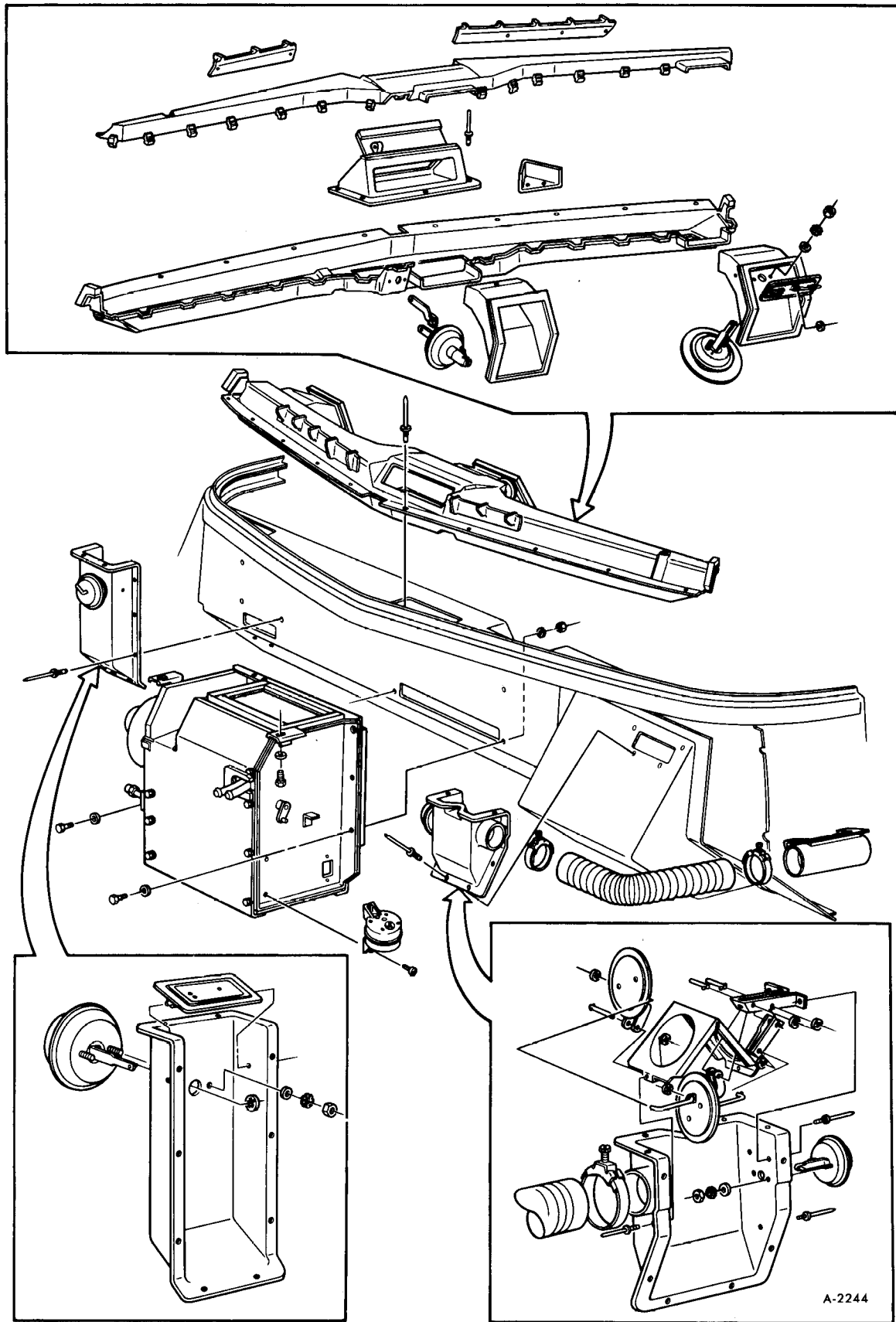

Figure 18-Blower Relay



A-2244

Figure 19-Vacuum Ducts and Controls



resistor must be discussed together because of their interrelations with each other. The blower switch located on the instrument panel regulates low, medium and high blower speeds through a blower resistor system. This resistor (figure 14) regulates the amount of current fed to the blower thereby regulating the blower speed. The blower relay (figure 18) provides the proper connections for the low and medium speeds through the resistor assembly and direct battery current to the blower for high speed.

## VACUUM COMPONENTS

The vacuum system (figure 19) consists of three basic components:

1. Vacuum tank.
2. Modes or vacuum switches.
3. Control Panel.

The vacuum tank is simply a reservoir of vacuum to be utilized when engine vacuum drops too low to effectively actuate the vacuum components.

The modes are diaphragm switches which open and close the various doors in the air movement system allowing "Heat" "Air Conditioning", "Defrost" and "Vent" as shown on the control panel (figure 21).

The control panel consists of a temperature valve and a select valve (See figure 20). This is the control center for directing vacuum through vacuum lines to

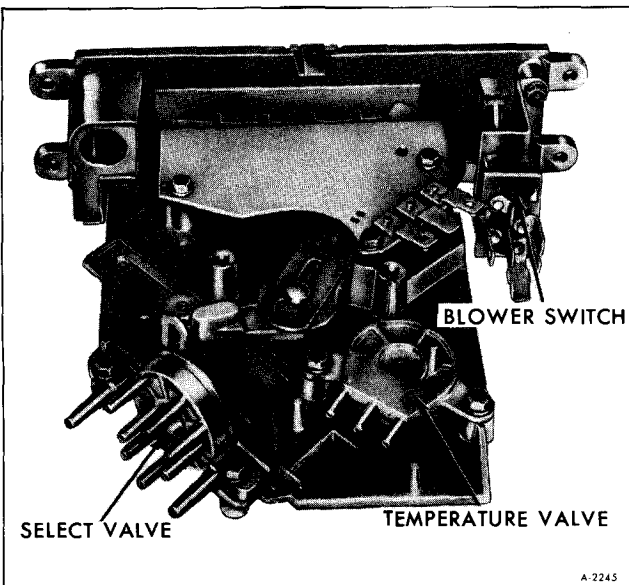

Figure 20—Control Panel Components

the different modes to achieve the temperatures desired for passenger and driver comfort. More information concerning the vacuum system and the routing of the lines and operation of the modes will be covered later in this section.

## PRIMARY CAUSES OF SYSTEM FAILURE

### Leaks

A shortage of refrigerant causes oil to be trapped in the evaporator. Oil may be lost with the refrigerant at point of leakage. Both of these can cause compressor seizure.

Oil circulates in the globules with the vapor. It leaves the compressor by the action of the pistons and mixes with the refrigerant liquid in the condenser. The oil then enters the evaporator with the liquid and, with the evaporator properly flooded, is returned to the compressor through the low pressure line. Some of the oil returns as globules in the vapor but more importantly, it is swept as a liquid along the walls of the tubing by the velocity of the vapor. If the evaporator is starved, the oil cannot return in sufficient quantities to keep the compressor properly lubricated.

### High Temperature and Pressure

An increase in temperature causes an increase in pressure. This accelerates chemical instability in clean systems. Other results are brittle hoses, "O" ring gaskets, and by-pass valve diaphragms with possible decomposition, broken compressor discharge reeds, and seized compressor bearings.

A fundamental law of nature accounts for the fact that when a substance, such as a refrigerant, is increased in temperature, its pressure is also increased.

Any chemical reactions caused by contaminants already in the system are greatly accelerated as the temperature increases. A 15° rise in temperature doubles the chemical action.

While temperature alone can cause the synthetic rubber parts to become brittle and possibly to decompose, the increased pressure can cause them to rupture or blow.

As the temperature and pressure increases, the stress and strain on the discharge reeds also increases. This can result in broken reeds. Due to the effect of the contaminants caused by high tempera-

ture and pressure, compressor bearings can be caused to seize.

High temperature and pressure is also caused by air in the system.

### **Air in the System**

Air results from a discharged system or careless servicing procedures. This reduces system capacity and efficiency and causes oxidation of oil into gum and varnish.

When a leak causes the system to become discharged, the resulting vacuum within the system will cause air to be drawn in. Air in a system is a non-condensable gas and will build up in the condenser as it would in an air compressor tank. The resultant heat produced will contribute to the conditions discussed previously.

Many systems are contaminated and also reduced in capacity and efficiency by careless servicing procedures.

Too frequently, systems which have been open to the atmosphere during service operations have not been properly purged or evacuated. Air is also introduced into the system by unpurged gauge and charging lines. Remember that any air in the system is too much air.

### **Poor Connections**

Hose clamp type fittings must be properly made. Hose should be installed over the sealing flanges and with the end of the hose at the stop flange. The hose should never extend beyond the stop flange. Locate the clamp properly and torque as recommended. Be especially careful that the sealing flanges are not nicked or scored or a future leak will result.

When compression fittings are used, over-tightening can cause physical damage to the "O" ring gasket and will result in leaks. The use of torque and backing wrenches is highly recommended. When making a connection with compression fittings, the gaskets should always be first placed over the tube before inserting it in the connection.

Another precaution - inspect the fitting for burrs which can cut the "O" ring.

### **Restrictions**

Restrictions may be due to powdered desiccant or dirt and foreign matter. This may result in starved evaporator and loss of cooling, high temperature at the bypass hose, or a seized compressor.

When the amount of moisture in a system sufficiently exceeds the capacity of the desiccant, it can break down the desiccant and cause it to powder. The powder passes through the dehydrator screen with the refrigerant liquid and is carried to the expansion valve screen. While some of it may pass through the valve screen into the evaporator, it may quickly build up to cause a restriction.

Due to the fact that sufficient oil then cannot be returned to the compressor, it may seize.

### **Dirt**

Dirt, which is any foreign material, may come from cleaner residues, cutting, machining, or preserving oils, metal dust or chips, lint or dust, loose rust, soldering or brazing fluxes, paint or loose oxide scale. These can also cause seized bearings by abrasion or wedging, discharge and expansion valve failure, decomposition of refrigerant and oil, or corrosion of metal parts.

### **Corrosion**

Corrosion and its by-products can restrict valve and drier screens, roughen bearing surfaces or hasten fatiguing of discharge reeds. This can result in high temperature and pressure, decomposition or leaks. In any event, this means a damaged compressor.

From this, we can see the vicious circle that can be produced in a refrigerating system to cause its failure. Corrosion can be the indirect cause of leaks and leaks can be the direct cause of corrosion. We can also see the important role servicemen play in maintaining chemical stability.

The major cause of corrosion is moisture.

### **Moisture**

Moisture is the greatest enemy of refrigerating systems. Combined with metal, it produces oxide, Iron Hydroxide, and Aluminum Hydroxide. Combined with R-12, it produces Carbonic acid, Hydrochloric acid, and Hydro-fluoric acid. Moisture can also cause freeze-up of an expansion valve and powdered desiccant.

Although high temperature and dirt are responsible for many difficulties in refrigerating systems, in most instances it is the presence of moisture in the system that accelerates these conditions. It can be said, therefore, that moisture is the greatest problem of all. The acids that it produces, in combination with both the metals and the refrigerant, causes damaging corrosion. While the corrosion may not form

as rapidly with R-12 as with some other refrigerants, the eventual formation is as damaging.

If the operating pressure and temperature in the evaporator is reduced to the freezing point, moisture in the refrigerant can collect at the orifice of the expansion valve and freeze. This temporarily restricts the flow of liquid causing erratic cooling.

As previously mentioned, moisture in excess of the desiccant's capacity can cause it to powder.

### Points to Remember

That the inside of the refrigerant system is completely sealed from the outside world. If that seal remains broken at any point – the system will soon be damaged.

That complete and positive sealing of the entire system is vitally important and that this sealed condition is absolutely necessary to retain the chemicals and keep them in a pure and proper condition.

That all parts of the refrigerant system are under pressure at all times, whether operating or idle, and that any leakage points are continuously losing refrigerant and oil.

That the leakage of refrigerant can be so silent that the complete charge may be lost without warning.

That refrigerant gas is heavier than air and will rapidly drop to the floor as it flows from a point of leakage.

That the pressure in the system may momentarily become as high as 480 lbs. per square inch.

That the total refrigerant charge circulates through the entire system at least once each minute.

That the compressor is continually giving up some lubricating oil to the circulating refrigerant and depends upon oil in the returning refrigerant for continuous replenishment. Any stoppage or major loss of refrigerant will therefore damage the compressor.

That the extreme internal dryness of a properly processed system is a truly desert condition, with the drying material in the receiver or accumulator holding tightly onto the tiny droplets of residual moisture.

That the attraction of the drying material for moisture is so powerful that if the receiver or accumulator is left open, moisture will be drawn in from the outside air.

That water added to the refrigerant will start chemical changes that can result in corrosion and eventual breakdown of the chemicals in the system. Hydrochloric acid is one result of an R-12 mixture with water.

That air in the refrigerant system may start reactions that can cause malfunctions.

That the drying agent in the receiver-dehydrator is Activated Silica Alumina.

That the inert gas in the expansion valve-capillary line is carbon dioxide.

## CONTROLS (FIGURE 21)

Combined air conditioning and heating system controls are located on the instrument panel in the upper right-hand corner. There are three separate controls; "FAN" lever, to control speed of blower; "OFF," "A/C," "VENT," "HEATER," "DEF" lever to control direction of air flow and which system is to be operated; "RECIRC," "COLD," "HOT" lever to control the temperature of the air. The three levers may be placed in many combined positions to deliver the climate conditions most desirable at any given time.

## OPERATION

"FAN" – the fan switch has four positions; "OFF" and three blower speeds ranging from "LO" to "HI." The fan will not operate unless the top lever has been moved from the "OFF" position, and in order to operate the fan in the "HI" position the engine must be running.

"OFF," "A/C," "VENT," "HEATER," "DEF" – With the lever in the "OFF" position the system is off. With the lever in the "A/C" position (and the "RECIRC," "COLD," "HOT" lever at "RECIRC," position) the air conditioning system is activated. This position uses 80% recirculated air.

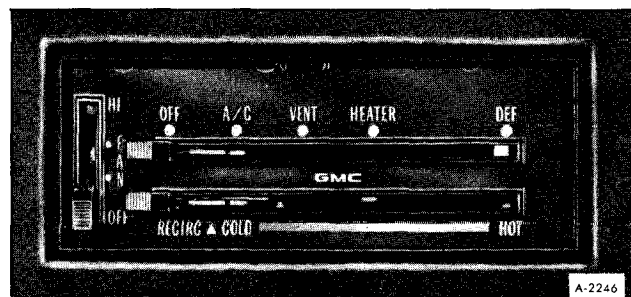

Figure 21—Air Conditioning Controls

This setting will provide maximum cooling. In combination with "A/C" setting moving the temperature lever to the "COLD" position provides 100% outside air. Further movement of the temperature lever to the right (toward "HOT" position) will heat the dehumidified air to the desired temperature. The "FAN" switch can be set to meet air flow requirements.

With the lever in the "VENT" position, 100% outside air enters the driver's compartment. This setting is for use during periods of less severe heat and humidity, air flow is identical to air flow in "A/C" position, however, the air conditioning compressor is not operating. Temperature of incoming air may be controlled by moving the temperature lever to the desired position. Any one of the three blower speeds may be selected.

With the lever in the "HEATER" position, air will flow through the heater floor distributor outlet (with a slight flow of air to the defroster outlet). For maximum heat, move the temperature lever to "HOT" position and "FAN" switch lever to "HI" position. Heating system output can be varied by moving temperature lever and "FAN" lever to different positions.

With the lever in "DEF" position, system operates the same as in the "HEATER" position except most of the air flow will be through the defroster outlets at the windshield.

"RECIRC," "COLD," "HOT" - This lever, used in conjunction with the system selector lever ("OFF," "A/C," "VENT," "HEATER," "DEF") and the "FAN" switch lever, will control the temperature of the output air being distributed.

**CAUTION:** Operate in "DEF" position for 30 seconds before switching to "A/C." This will remove humid air from the system and minimize rapid fogging of the glass which can occur if humid air is blown onto a cool windshield.

Clear windshield, rear window, outside mirrors, and all side windows of ice and snow before driving vehicle.

Operate blower on "HI" for a few seconds before moving the vehicle, to clear the air intakes of snow.

## GENERAL INFORMATION

In any vocation or trade, there are established procedures and practices that have been developed after many years of experience. In addition, occupational hazards may be present that require the observation of certain precautions or use of special tools and equipment. Observing the procedures, practices and precautions of servicing refrigeration equipment will greatly reduce the possibilities of damage to the customers' equipment as well as virtually eliminate the element of hazard to the serviceman.

### PRECAUTIONS IN HANDLING REFRIGERANT-12

Refrigerant-12 is transparent and colorless in both the gaseous and liquid state. It has a boiling point of 21.7°F below zero and, therefore, at all normal temperatures and pressures it will be a vapor. The vapor is heavier than air, and is noninflammable, nonexplosive, nonpoisonous (except when in contact with an open flame) and noncorrosive (except when in contact with water).

**WARNING: THE FOLLOWING PRECAUTIONS IN HANDLING R-12 SHOULD BE OBSERVED AT ALL TIMES.**

1. Refrigerant should not be exposed to the radiant heat from the sun since the resulting increase in pressure may cause the safety valve to release or the cylinder or can to burst.

2. Cylinders or disposable cans should never be subjected to high temperature when adding refrigerant to the system. In most instances, heating the cylinder or can is required to raise the pressure in the container higher than the pressure in the system during the operation. It would be unwise to place the cylinder on a gas stove, radiator or use a blow torch while preparing for the charging operation, for a serious accident can result. Remember, high pressure means that great forces are being exerted against the walls of the container. A bucket of warm water, not over 125°F, or warm wet rags round the container is all the heat that is required.

3. Do not weld or steam clean on or near the system. Welding or steam cleaning can result in a dangerous pressure buildup in the system.

4. Discharging large quantities of R-12 into a room can usually be done safely as the vapor would produce no ill effects; however, in the event of an accidental rapid discharge of the system, it is recommended that inhalation of large quantities of R-12 be

avoided. This caution is especially important if the area contains a flame producing device such as a gas heater. While R-12 normally is nonpoisonous, heavy concentrations of it in contact with a live flame will produce a toxic gas. The same gas will also attack all bright metal surfaces.

5. Protection of the eyes is of vital importance! When working around a refrigerating system, an accident may cause liquid refrigerant to hit the face. If the eyes are protected with goggles or glasses, no serious damage can result. Just remember, any R-12 liquid that touches you is at least 21.7°F below zero. If R-12 liquid should strike the eyes, here is what to do:

A. Keep calm.

B. Do not rub the eyes. Splash the affected area with quantities of cold water to gradually get the temperature above the freezing point. The use of mineral, cod liver or an antiseptic oil is important in providing a protective film to reduce the possibility of infection.

C. As soon as possible, call or consult an eye specialist for immediate and future treatment.

## PRECAUTIONS IN HANDLING REFRIGERANT LINES

**CAUTION:** *The following precautions should be observed when handling refrigerant lines:*

1. All metal tubing lines should be free of kinks, because of the restriction that kinks will offer to the flow of refrigerant. The refrigeration capacity of the entire system can be greatly reduced by a single kink.
2. The flexible hose lines should never be bent to a radius of less than 10 times the diameter of the hose.
3. The flexible hose lines should never be allowed to come within a distance of 2-1/2" of the exhaust manifold.
4. Flexible hose lines should be inspected at least once a year for leaks or brittleness. If found brittle or leaking they should be replaced with new lines.
5. Use only new lines that have been sealed during storage.
6. When disconnecting any fitting in the refrigeration system, the system must first be discharged of all refrigerant. However, proceed very cautiously re-

gardless of gauge readings. Open very slowly, keeping face and hands away so that no injury can occur if there happens to be liquid refrigerant in the line. If pressure is noticed when fitting is loosened, allow it to bleed off as described under "Purging the System" in this section.

**WARNING: ALWAYS WEAR SAFETY GOGGLES WHEN OPENING REFRIGERANT LINES.**

7. In the event any line is opened to atmosphere, it should be immediately capped to prevent entrance of moisture and dirt.

8. The use of the proper wrenches when making connections on "O" ring fittings is important. The use of improper wrenches may damage the connection. The opposing fitting should always be backed up with a wrench to prevent distortion of connecting lines or components. When connecting the flexible hose connections it is important that the swaged fitting and the flare nut, as well as the coupling to which it is attached, be held at the same time using three different wrenches to prevent turning the fitting and damaging the ground seat.

9. "O" rings and seats must be in perfect condition. A burr or piece of dirt may cause a leak.

10. Sealing beads on hose clamp connections must be free of nicks and scratches to assure a perfect seal.

## MAINTAINING CHEMICAL STABILITY IN THE REFRIGERATION SYSTEM

The metal internal parts of the refrigeration system and the refrigerant and oil contained in the system are designed to remain in a state of chemical stability as long as pure R-12 and uncontaminated refrigeration oil is used in the system.

However, when abnormal amounts of foreign materials, such as dirt, air or moisture are allowed to enter the system, the chemical stability may be upset. When accelerated by heat, these contaminants may form acids and sludge and eventually cause the breakdown of components within the system. In addition, contaminants may affect the temperature-pressure relationship of R-12, resulting in improper operating temperature and pressures and decreased efficiency of the system.

*The following general practices should be observed to ensure chemical stability in the system:*

1. Whenever it becomes necessary to disconnect a refrigerant or gauge line, it should be immediately capped. Capping the tubing will also prevent dirt and foreign matter from entering.

2. Tools should be kept clean and dry. This also includes the gauge set and replacement parts.

3. When adding oil, the container should be exceptionally clean and dry due to the fact that the refrigeration oil in the container is as moisture-free as it is possible to make it; therefore, it will quickly absorb any moisture with which it comes in contact. For this same reason the oil container should not be opened until ready for use and then it should be capped immediately after use.

4. When it is necessary to open a system, have everything you will need ready and handy so that as little time as possible will be required to perform the operation. Don't leave the system open any longer than is necessary.

5. Finally, after the operation has been completed and the system sealed again, air and moisture should be evacuated from the system before recharging.

## CHARGING STATION J-24410

This portable air conditioner service station (figure 22) features the new J-24364 High Capacity Vacuum Pump. Utilization of J-24364 enables the J-24410 service station to out-perform all competitive stations in the automotive field today.

The capacity of the J-24364 is three cubic feet per minute; four times that of the J-5428-03 which pumps at a rate of .8 cubic feet per minute. A vented exhaust aids in the removal of moisture at a much faster rate.

With the added increases in capacity the new J-24410 will enable a serviceman to perform the evacuation procedure in an automotive air conditioning system in one third less time. This of course is a money saving feature.

The J-24410 incorporates two compound gauges. The second compound gauge is used to permit checking of other Motor Home manufacturer's systems at the evaporator pressure release valve. The CMN fast flow manifold incorporates a new O ring stem which permits the manifold to be opened or closed in two and a half turns.

This station is equipped with a controlled heated cylinder which assures a complete charge into the high pressure side of the compressor. This feature reduces the charging time considerably and enables

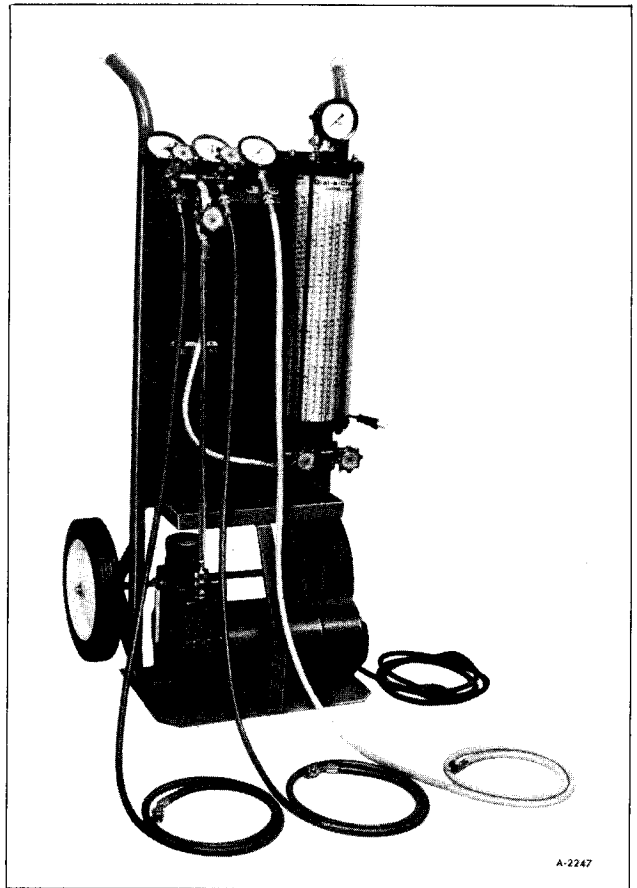

Figure 22—Charging Station J-24410

a complete and accurately measured charge without running the engine!

The line from the manifold to the pump is 3/8" I.D. copper tube which is a larger I.D. for less restriction on pull down. The cylinder is graduated for Refrigerant-12 and Refrigerant-22. Refrigerant-22 is used in some of the refrigerant systems on recreational vehicles. Also the cylinder has a heating element to provide a positive pressure advantage to overcome system pressure equalization.

## GAUGE SET

The gauge set is an integral part of the Charging Station. It is used when purging, evacuating, charging or diagnosing trouble in the system. The gauge at the left is known as the low pressure gauge. The face is graduated into pounds of pressure and, in the opposite direction, in inches of vacuum. This is the gauge that should always be used in checking pressures on the low pressure side of the system. When all parts of the system are functioning properly the refrigerant pressure on the low pressure side never

falls below 0 pounds pressure. However, several abnormal conditions can occur that will cause the low pressure to fall into a partial vacuum. Therefore, a low pressure gauge is required.

The high pressure gauge is used for checking pressures on the high pressure side of the system.

The hand shutoff valves on the gauge manifold do not control the opening or closing off of pressure to the gauges. They merely close each opening to the center connector and to each other. During most diagnosing and service operation, the valves must be closed. Both valves will be open at the same time during purging, evacuating and charging operations.

The charging station provides two flexible lines for connecting the gauge set to the system components.

## VACUUM PUMP

A vacuum pump should be used for evacuating air and moisture from the air conditioning system.

The vacuum pump (figure 22), is a component part of Charging Station described previously.

**CAUTION:** *The following precautions should be observed relative to the operation and maintenance of this pump:*

1. Make sure dust cap on discharge outlet of vacuum pump is removed before operating.
2. Keep all openings capped when not in use to avoid moisture being drawn into the system.
3. Oil should be changed after every 250 hours of normal operation.

To change oil, simply unscrew hex nut located on back side of pump, tilt backward and drain out oil. Recharge with 8 ounces of vacuum pump oil Frigidaire 150 or equivalent. If you desire to flush out the pump, use this same type clean oil. Do not use solvent. Improper Lubrication will shorten pump life.

4. If this pump is subjected to extreme or prolonged cold, allow it to remain indoors until oil has reached approximate room temperature. Failure to warm oil will result in a blown fuse.

5. A five ampere time delay cartridge fuse has been installed in the common line to protect the windings of the compressor. The fuse will blow if an excessive load is placed on the pump. In the event the

fuse is blown, replace with a five ampere time delay fuse. **Do not use a substitute fuse** as it will result in damage to the starting windings.

6. If the pump is being utilized to evacuate a burnt-out system, a filter must be connected to the intake fitting to prevent any sludge from contaminating the working parts, which will result in malfunction of the pump.

7. Do not use the vacuum pump as an air compressor.

## LEAK TESTING THE SYSTEM

Whenever a refrigerant leak is suspected in the system or a service operation performed which results in disturbing lines or connections, it is advisable to test for leaks. Common sense should be the governing factor in performing any leak test, since the necessity and extent of any such test will, in general, depend upon the nature of the complaint and the type of service performed on the system.

## LEAK DETECTOR

Tool J-6084 (figure 23) is a propane gas-burning torch which is used to locate a leak in any part of the system. Refrigerant gas drawn into the sampling tube attached to the torch will cause the torch flame

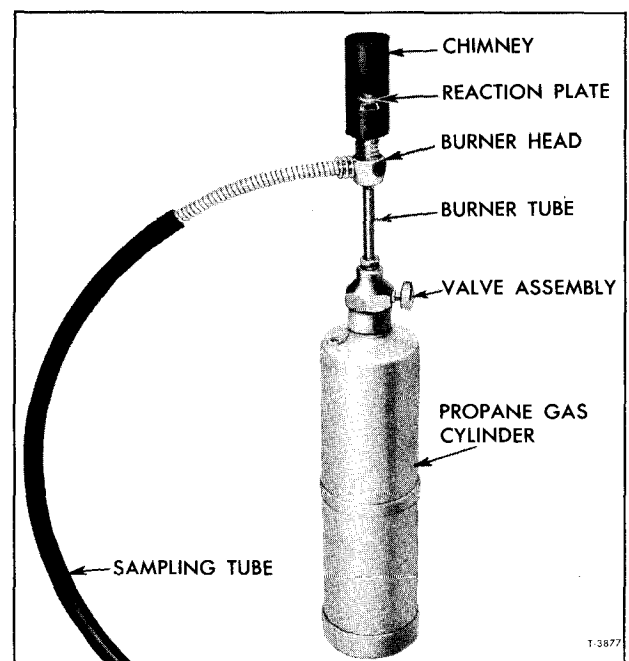

Figure 23—Leak Detector J-6084

to change color in proportion to the size of the leak. Propane gas fuel cylinders used with the torch are readily available commercially throughout the country.

**WARNING: DO NOT USE LIGHTED DETECTOR IN ANY PLACE WHERE COMBUSTIBLE OR EXPLOSIVE GASES, DUSTS OR VAPORS MAY BE PRESENT.**

## OPERATING DETECTOR

1. Determine if there is sufficient refrigerant in the system for leak testing.
2. Open control valve only until a low hiss of gas is heard, then light gas at opening in chimney.
3. Adjust flame until desired volume is obtained. This is most satisfactory when blue flame is approximately 3/8" above reactor plate. The reaction plate will quickly heat to a cherry red.
4. Explore for leaks by moving the end of the sampling hose around possible leak points in the system. Do not pinch or kink hose.

**NOTE:** Since R-12 is heavier than air, it is good practice to place open end of sampling tube immediately below point being tested, particularly in cases of small leaks.

**WARNING: DO NOT BREATHE THE FUMES THAT ARE PRODUCED BY THE BURNING OF R-12 GAS IN THE DETECTOR FLAME, SINCE SUCH FUMES CAN BE TOXIC IN LARGE CONCENTRATIONS.**

5. Watch for color changes. The color of the flame which passes through the reaction plate will change to green or yellow-green when sampling hose draws in very small leaks of R-12. Large leaks will be indicated by a change in color to a brilliant blue or purple; when the sampling hose passes the leaks, the flame will clear to an almost colorless pale-blue again. Observations are best made in a semidarkened area. If the flame remains yellow when unit is removed from leak, insufficient air is being drawn in or the reaction plate is dirty.

**NOTE:** A refrigerant leak in the high pressure side of the system may be more easily detected if the system is operated for a few minutes, then shut off and checked immediately (before system pressures equalize). A leak on the low pressure side may be more easily detected after the engine has been shut off for several minutes (system

pressures equalized); this applies particularly to the front seal.

## AVAILABILITY OF REFRIGERANT-12

Refrigerant-12 is available in 30 lb. and in 15 oz. disposable containers.

Normally, air conditioning systems are charged making use of the Charging Station which uses the 30 lb. container. Evacuating and charging procedures are noted later in this section.

The 15 oz. disposable cans are generally used for miscellaneous operations such as flushing.

**WARNING: THE FOLLOWING PRECAUTIONS SHOULD BE OBSERVED WHEN ADDING REFRIGERANT TO A SYSTEM USING 15 OZ. DISPOSABLE CANS:**

1. Do not charge while compressor system is hot.
2. Empty container completely before disposing.
3. Use opening valves designed for use with container - follow valve manufacturer's directions carefully.
4. Always use pressure gauges before and during charging.
5. NEVER connect on high pressure side of system or to any system having a pressure higher than indicated on refrigerant containers.
6. If inexperienced, seek professional assistance.

## COMPRESSOR OIL

Special refrigeration lubricant should be used in the system. This oil is as free from moisture and contaminants as it is possible to attain by human processes. This condition should be preserved by immediately capping the bottle when not in use.

See "Air Conditioning System Capacities" for the total system oil capacity.

Due to the porosity of the refrigerant hoses and connections, the system refrigerant level will show a definite drop after a period of time. Since the compressor oil is carried throughout the entire system mixed with the refrigerant, a low refrigerant level will cause a dangerous lack of lubrication. Therefore



the refrigerant charge in the system has a definite tie-in with the amount of oil found in the compressor and an insufficient charge may eventually lead to an oil build-up in the evaporator.

serial number plate on top of the compressor. The serial number consists of a series of numbers and letters. This serial number should be referenced on all forms and correspondence related to the servicing of this assembly.

## COMPRESSOR SERIAL NUMBER

The compressor serial number is located on the

## INSPECTION AND PERIODIC SERVICE

### PRE-DELIVERY INSPECTION

1. Check that engine exhaust is suitably ventilated.
2. Check the belt for proper tension.
3. With controls positioned for operation of the system, operate the unit for five minutes at approximately 2000 rpm. Observe the clutch pulley bolt to see that the compressor is operating at the same speed as the clutch pulley. Any speed variation indicates clutch slippage.
4. Before turning off the engine, check refrigerant charge (see "Refrigerant Quick Check Procedure").
5. Check refrigerant hose connections:

**"O" Ring Connections** - Check torque of fittings as charted later in this section under "Refrigerant Line Connections;" retorque if required. Leak test the complete system.

6. If there is evidence of an oil leak, check the compressor to see that the oil charge is satisfactory.

**NOTE:** A slight amount of oil leakage at the compressor front seal is considered normal.

7. Check the system controls for proper operation.

### 6000 MILE INSPECTION

1. Check unit for any indication of a refrigerant leak.

## EVACUATING AND CHARGING PROCEDURES

### AIR CONDITIONING SYSTEM CAPACITY

The Motor Home automotive air conditioning system has a refrigerant capacity of 3.5 lbs.

2. If there is an indication of an oil leak, check the compressor for proper oil charge.

**NOTE:** A slight amount of oil leakage at the compressor front seal is considered normal.

3. Check refrigerant charge (see "Refrigerant Quick Check Procedure").
4. Tighten the compressor brace and support bolts and check the belt tension.
5. Check refrigerant hose connections as in Step 5 of "Pre-Delivery Inspection."

### PERIODIC SERVICE

1. Inspect condenser regularly to be sure that the fins are not plugged with leaves or other foreign material.

Also check to be sure fins are not folded over blocking air flow. Fins may be straightened.

2. Check evaporator drain tubes regularly for dirt or restrictions.

3. At least once a year, check the system for proper refrigerant charge and the flexible hoses for brittleness, wear or leaks.

4. Every 6000 miles check for low refrigerant level.

5. Check belt tension regularly.

### INSTALLING CHARGING STATION

1. High and low pressure gauge line fittings are provided in the air conditioning system for attaching the Charging Station. The compressor inlet line and

the high pressure fitting is on the compressor outlet line.

2. With the engine stopped, remove the caps from the cored valve gauge fittings.

3. Install Gauge Adapters J-5420 and J-9459 onto the high and low pressure lines of the Charging Station.

4. Be certain all the valves on the Charging Station are closed.

5. Connect the high pressure gauge line to the high pressure fitting on the system.

6. Referring to Figure 24, turn the high pressure control one turn counterclockwise (open). Crack open the low pressure control and allow refrigerant gas to hiss from the low pressure gauge line for three seconds, and then connect the low pressure line to the low pressure fitting on the system.

**WARNING: WHEN REMOVING THE GAUGE LINES FROM THE FITTINGS, BE SURE TO REMOVE THE ADAPTERS FROM THE SYSTEM FITTINGS RATHER THAN THE GAUGE LINES FROM THE ADAPTER.**

7. The system is now ready for purging or performance testing.

## PURGING THE SYSTEM

In replacing any of the air conditioning components, the system must be completely purged or

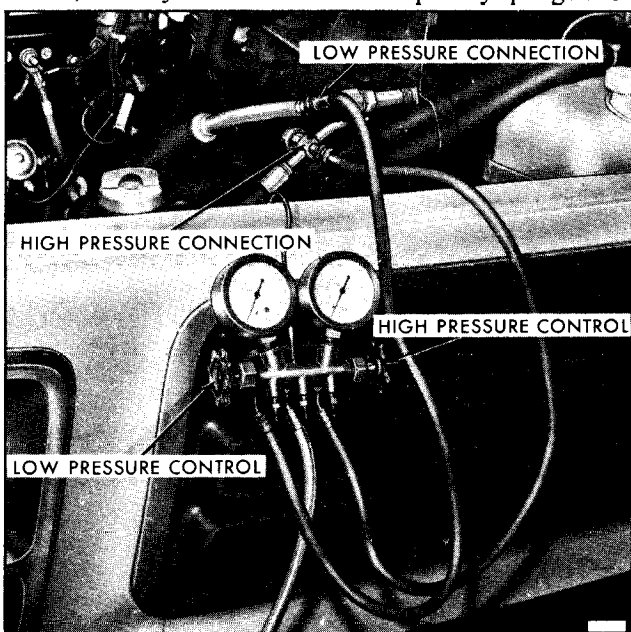

Figure 24—Charging Station Installed

drained of refrigerant. The purpose is to lower the pressure inside the system so that a component part can be safely removed.

1. With the engine stopped, install high and low pressure lines of Charging Station gauge set to the proper high and low pressure gauge fittings (See “Installing The Charging Station”).

**CAUTION:** *Before installing lines, be sure that all four controls on the gauge set are closed.*

2. Disconnect vacuum line at Charging Station vacuum pump and put the line in a covered can.

**NOTE:** An empty 3 lb. coffee can with a plastic cover which has been cross-slit (X’ed), to allow home entry, works well for this purpose.

3. Fully open high (2) and low (1) pressure control valves, and allow refrigerant to purge from system at a rapid rate into the covered can.

4. Oil loss will be minimal. It may be added to the system during evacuation as described later.

5. Toward the end of the purge stage, Tool J-24095 should be flushed with refrigerant to eliminate possible contamination.

a. Disconnect refrigerant line at supply tank.

b. Flush Tool J-24095 by cracking open valve on refrigerant tank. After flushing for approximately three seconds, close valve.

c. Temporarily refasten the tool.

d. Reconnect refrigerant line to supply tank.

## EVACUATING AND CHARGING THE SYSTEM

**NOTE:** In all evacuating procedures shown below, the specification of 28-29 inches of Mercury vacuum is used. These figures are only attainable at or near Sea Level Elevation. For each 1000 feet above sea level where this operation is being performed, the specifications should be lowered by 1 inch. Example: at + 5000 ft. elevation, only 23 to 24 inches of vacuum can normally be obtained.

Whenever the air conditioning system is open for any reason, it should not be put into operation again

until it has been evacuated to remove air and moisture which may have entered the system.

The following procedures are based on the use of the J-24410 Charging Station:

## ADDING OIL

If necessary, refrigeration oil may be added to the system by the following method:

1. Install charging station and purge system as previously described.
2. After system has been purged, connect the vacuum line to the vacuum pump.
3. Measure oil loss collected as a result of purging the system.
  - a. Disconnect the Charging Station low pressure line. Install Tool J-24095 (with valve closed) onto the system low pressure fitting. Insert pickup tube into graduated container of clean refrigerant oil (figure 25).

**NOTE:** Tool J-24095 will hold 1/2 of an ounce of oil in the tool itself. So if 1 oz. has to be added, the level of the oil in the bottle should decrease 1-1/2 ounces to add 1 oz. to the system.

**CAUTION:** *When removing the gauge lines from the fittings, be sure to remove the adapters from the system fittings rather than the gauge lines from the adapter.*

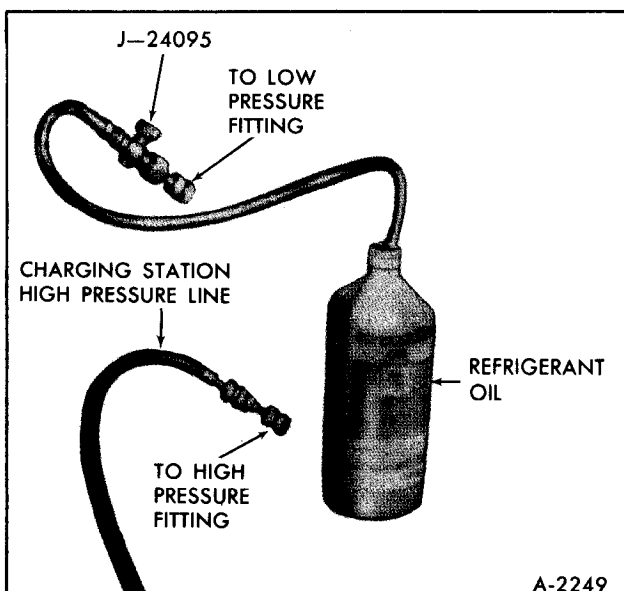

Figure 25—Adding Refrigeration Oil

b. Turn on vacuum pump, and open vacuum control valve (slowly open high pressure side of manifold gauge set to avoid forcing oil out of refrigerant system and pump).

**NOTE:** When valve on Tool J-24095 is opened, the vacuum applied to the discharge side of the system will suck oil into system from container. Therefore, close observation of oil level in the container is necessary.

c. Note level of oil in container. Open valve on oil adding tool until oil level in container is reduced by an amount equal to that lost during discharge of system plus 1/2 ounce, then close valve. **Take care not to add more oil than was lost.**

d. Disconnect and cap Tool J-24095 and reinstall charging station low pressure line to the system. Open low pressure valve.

## EVACUATION

After oil has been added to the system (as outlined above), run pump until 28-29 inches vacuum is obtained (See Note under "Evacuating and Charging the System"). Continue to run pump for 10 minutes after the system reaches 28-29 inches vacuum.

**NOTE:** If 28-29 inches cannot be obtained, close Vacuum Control Valve and shut off vacuum pump. Open Refrigerant Control Valve and allow 1/2 pound of R-12 to enter system. Locate and repair all leaks. Purge this 1/2 pound and re-evacuate for 10 minutes.

1. During the ten minute evacuation period, prepare for charging the system by filling the charging cylinder as follows:

a. Open valve on bottom of charging cylinder allowing refrigerant to enter cylinder.

**NOTE:** It will be necessary to close bleed valve periodically to allow boiling to subside to check level in the sight glass of Charging Station cylinder.

b. Bleed cylinder valve on top (behind control panel) as required to allow refrigerant to enter. When refrigerant reaches desired level (see "System Capacity"), close valve at bottom of cylinder and be certain bleed valve is closed securely.

2. Continue to evacuate for remainder of 10 minute period.

3. Turn hand shut-off valves at low and high pressure gauges of gauge set to full clockwise position with vacuum pump operating, then stop pump. Carefully check low pressure gauge for approximately two minutes to see that vacuum remains constant. If vacuum reduces, it indicates a leak in the system or gauge connections; locate and repair all leaks.

## CHARGING THE SYSTEM

1. Only after evacuating as above, is system ready for charging. Note reading on sight glass of charging cylinder. If it does not contain a sufficient amount of refrigerant for a full charge, fill to the proper level.

2. With High and Low Pressure Valves open, close Vacuum Control Valve, turn off vacuum pump, open refrigerant control valve and allow refrigerant to enter system.

**NOTE:** If the charge will not transfer completely from the station to the system, close the high pressure valve at the gauge set, set the air conditioning controls for cooling, check that the engine compartment is clear of obstructions, and start the engine. Compressor operation will decrease the low side pressure in the system.

System is now charged and should be checked as outlined below:

## CHECKING SYSTEM OPERATION

1. Operate system for a maximum of five minutes at maximum cooling, high blower speed and with engine operating at 2000 RPM (exhaust should be vented if inside).

2. When system is stabilized, the pressure gauges on the charging station should read pressures corresponding to values listed under **PERFORMANCE DATA**.

3. When correct system pressures are observed, check system charge as described under "Refrigerant Quick Check Procedure".

4. Feel outlet air distribution to ensure that cold air is being distributed.

5. Disconnect gauge lines and cap fittings.

**CAUTION:** *When removing gauge lines from fittings, be sure to remove the adapters from*

*the fittings rather than the gauge lines from the adapters.*

## PERFORMANCE TEST

Under normal circumstances, it will not be necessary to Performance Test a system as outlined below; however, in certain instances, the following procedure may be advantageous in diagnosing system malfunction.

The following fixed conditions must be adhered to in order to make it possible to compare the performance of the system being tested with the standards below:

1. Doors and windows closed. (Vehicle inside or in shade.) Close driver's compartment curtains.

2. Vehicle in NEUTRAL with engine running at 2000 rpm.

3. Air Conditioning controls set for -

- Maximum cooling.
- High blower speed.

5. TEMP control set at "RECIRC" and all air conditioning outlets open.

6. Gauge set installed.

7. System settled out (run-in approximately 10 minutes).

8. A thermometer placed in front of vehicle grille and another in the center diffuser outlet.

9. An 18" fan placed in front of the vehicle and blowing into the condenser.

**NOTE:** Higher temperatures and pressures will occur at higher ambient temperatures. In areas of high humidity it is possible to have thermometer and gauge readings approach but not reach the figures listed in the performance table and still have a satisfactory operating unit. However, it is important to remember that low pressure has a direct relationship to nozzle outlet temperature. If pressure is too low, ice will gradually form on the evaporator fins, restricting air flow into the passenger area and resulting in insufficient or no cooling.

## PERFORMANCE DATA

The following Performance Data define normal operation of the system under the above conditions.

Relative humidity does not appear in the tables because after running the prescribed length of time on recirculated air and maximum cooling, the relative humidity of the air passing over the evaporator core will remain at approximately 35% to 40% regardless of the ambient temperature or humidity.

(Refrigerant Charge – 3.5 lbs.)						
Temperature of Air Entering Condenser	70°	80°	90°	100°	110°	120°
Engine rpm	2000 RPM					
Compressor Head Pressure*	130 - 145	150 - 165	160 - 175	180 - 195	205 - 220	240 - 255
Suction Pressure*	8 - 10	8 - 10	8 - 10	8 - 10	11 - 14	12 - 15
Discharge Air Temp. at Right Upper Outlet*	41 - 44	41 - 44	42 - 45	45 - 48	50 - 53	55 - 58

\*Just prior to compressor clutch disengagement

### CHECKING OIL

In the six cylinder compressor it is not recommended that the oil be checked as a matter of course. Generally, compressor oil level should be checked only where there is evidence of a major loss of system oil such as might be caused by:

- A broken refrigerant hose
- A severe hose fitting leak
- A very badly leaking compressor seal
- Collision damage to the system components

As a quick check on compressor oil charge, operate the engine at *idle* on maximum cold for approximately 10 minutes, turn off the engine and momentarily crack open the oil drain plug on bottom of the compressor letting a slight amount of oil drain out. Retighten plug. Again slightly crack open the plug. If oil comes out, the compressor has the required amount of oil.

Evaporator Core .....	3 fluid oz.
Condenser.....	1 fluid oz.
Receiver-Dehydrator .....	1 fluid oz.

**CAUTION:** When adding oil to the compressor, it will be necessary to tilt the rear end of the compressor up so that the oil will not

**NOTE:** The oil may appear foamy. This is considered normal.

To further check the compressor oil charge, should the above test show insufficient oil, it is necessary to remove the compressor from the vehicle, drain and measure the oil as outlined under "Checking Compressor Oil Charge."

### CHECKING COMPRESSOR OIL CHARGE

1. Run the system for 10 minutes at 600 engine rpm with controls set for maximum cooling and high blower speed.

2. Turn off engine, discharge the system, remove compressor from vehicle, place it in a horizontal position with the drain plug downward. Remove the drain plug and, tipping the compressor back and forth and rotating the compressor shaft, drain the oil into a clean container, measure and discard the oil.

3. Add new refrigeration oil to the compressor as follows.

a. If the quantity drained was 4 fluid oz. or more, add the same amount of new refrigeration oil to the replacement compressor.

b. If the quantity drained was less than 4 fluid oz., add 6 fluid oz. of new refrigeration oil to the replacement compressor.

c. If a new service compressor is being installed, drain all oil from it and replace only the amount specified in Steps 3a and 3b above.

d. If a field repaired compressor is being installed, add an additional 1 fluid oz. to the compressor.

e. If the oil contains chips or other foreign material, flush or replace all component parts as necessary. Add the full 10 fluid oz. of new refrigeration oil to the replacement compressor.

4. Add additional oil in the following amounts for any system components being replaced.

*run out of the suction and discharge ports. Do not set the compressor on the shaft end.*

## REFRIGERANT QUICK-CHECK PROCEDURE

The following procedure can be used to quickly determine whether or not an air conditioning system has a proper charge of refrigerant. This check can be made in a manner of minutes thus facilitating system diagnosis by pinpointing the problem to the amount of charge in the system or by eliminating this possibility from the overall checkout.

Start engine and place on fast idle. Set controls for maximum cold with blower on high.

<p>Bubbles present in sight glass. System low on charge. Check with leak detector. Correct leak, if any, and fill system to proper charge.</p>	<p>No bubbles. Sight glass clear. System is either fully charged or empty. Feel high and low pressure pipes at compressor. High pressure pipe should be warm; low pressure pipe should be cold.</p>
<p>No appreciable temperature differential noted at compressor. System empty or nearly empty. Turn off engine and connect Charging Station. Induce 1/2# of refrigerant in system (if system will not accept charge, start engine and draw 1/2# in through low pressure side). Check system with leak detector.</p>	<p>Temperature differential noted at compressor. Even though a differential is noted, there exists a possibility of overcharge. An overfilled system will result in poor cooling during low speed operation (as a result of excessive head pressure), An overfill is easily checked by disconnecting the compressor clutch connector while observing the sight glass.</p>
<p>If refrigerant in sight glass remains clear for more than 45 seconds (before foaming and then setting away from sight glass) an overcharge is indicated. Verify with a performance check.</p>	<p>If refrigerant foams and then settles away from sight glass in less than 45 seconds, it can be assumed that there is a proper charge of refrigerant in system. Continue checking out system using performance checks outlined previously.</p>

## MAINTENANCE AND ADJUSTMENTS

### THERMOSTATIC SWITCH

The system makes use of a thermostatic switch with an air sensing capillary. This capillary controls the switch by sensing the temperature of the air leaving the fins.

### CHECKING FOR PROPER OPERATION

1. Install the gauge set and set up the vehicle as described under "Performance Test".

2. Set the control at A/C, HI blower, max COLD and run the engine at 2000 rpm.

a. The thermostatic switch should cycle the compressor off when the low limit of the outlet air temperature is reached (see Performance Data). If it does not, the switch points are fused which will lead to evaporator freeze up. Replace the switch.

b. If the compressor does not operate, a loss of power element charge is indicated (provided that it has been established that power is supplied to the switch). This, of course, results in no cooling. Replace the switch.

c. Check the switch adjusting screw for stripped or otherwise damaged threads.

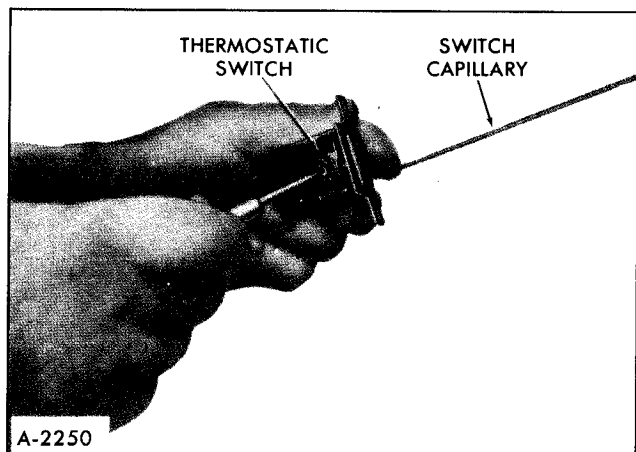

Figure 26—Adjusting Thermostatic Switch

## ADJUSTING SWITCH

If, after the above checks, the switch seems to be operating properly, adjust for proper setting if necessary, as follows:

1. Vehicle must be set up as described in "Performance Test."

2. The suction side of the system, read on the low pressure gauge, should pull down to the pressure shown in the chart in "Performance Data" under the ambient temperature at the time the switch is being set.

3. Remove the switch as outlined in the "General Repair Procedures" section.

4. Remove the switch non-metal end plate to gain access to the switch adjusting screw.

5. If the outlet temperature was less than the prescribed temperature at the end of each cooling cycle, turn the adjusting screw a partial turn counter-clockwise (figure 26). If the outlet temperature was more than prescribed temperature, turn the adjusting screw clockwise.

**NOTE:** One turn of the adjusting screw will change the outlet temperature approximately 4 degrees.

6. Reinstall switch end plate and reinstall switch. Be sure that the air sensing capillary has been replaced properly.

7. Check system performance. If further adjustment is needed, repeat Steps 3 through 6 until the prescribed pressure is reached.

**NOTE:** Do not attempt to run a Performance Check with the system disassembled since inac-

curate readings would be the result. ALWAYS reinstall switch and capillary and any duct work before running a performance check.

## EXPANSION VALVE (FIGURE 14)

A malfunction of the expansion valve will be caused by one of the following conditions; valve stuck open, valve stuck closed, broken power element, a restricted screen or an improperly located or installed power element bulb.

Attachment of the expansion valve bulb to the evaporator outlet pipe is very critical. The bulb must be attached tightly to the pipe and must make good contact with the pipe along the entire length of the bulb. A loose bulb will result in high "high side" pressures and poor cooling. On bulbs located outside the evaporator case, insulation must be properly installed.

Indications of expansion valve trouble provided by the Performance Test are as follows:

### VALVE STUCK OPEN

Noisy Compressor.

No Cooling - Freeze Up.

### VALVE STUCK CLOSED, PLUGGED SCREEN OR BROKEN POWER ELEMENT

Very Low Suction Pressure.

No Cooling.

### POORLY LOCATED POWER ELEMENT BULB

Normal Pressure.

Poor Cooling.

## CHECK FOR DEFECTIVE VALVE

The following procedure must be followed to determine if a malfunction is due to a defective expansion valve.

1. Check to determine if the system will meet the performance test as outlined previously. If the expansion valve is defective, the low pressure readings will be above specification.

2. The loss of system performance is not as evident when the high side pressure is below 200 PSI. Therefore, it may be necessary to increase the system high side pressure by partially blocking the condenser. Disconnect the blower lead wire and repeat the "Performance Check" to determine if the low side pressure can be obtained.

# GENERAL REPAIR PROCEDURES AND COMPONENT REPLACEMENT

## PREPARING SYSTEM FOR REPLACEMENT OF COMPONENT PARTS

Air conditioning, like many other things, is fairly simple to service once it is understood. However, there are certain procedures, practices and precautions that should be followed. For this reason it is strongly recommended that the preceding information in this section be studied thoroughly before attempting to service the system.

Great emphasis must be placed upon keeping the system clean. Use plugs or caps to close system components and hoses when they are opened to the atmosphere. Keep your work area clean.

In removing and replacing any part which requires unsealing the refrigerant circuit the following operations, which are described in this section, must be performed in the sequence shown.

1. Purge the system by releasing the refrigerant to the atmosphere.
2. Remove and replace the defective part.
3. Evacuate, charge and check the system.

**WARNING: ALWAYS WEAR PROTECTIVE GOGGLES WHEN WORKING ON REFRIGERATION SYSTEMS. GOGGLES J-5453 ARE INCLUDED IN THE SET OF AIR CONDITIONING SPECIAL TOOLS. ALSO, BEWARE OF THE DANGER OF CARBON MONOXIDE FUMES BY AVOIDING RUNNING THE ENGINE IN CLOSED OR IMPROPERLY VENTILATED GARAGES.**

## FOREIGN MATERIAL IN THE SYSTEM

Whenever foreign material is found in the system, it must be removed before restoring the system to operation.

In the case of compressor mechanical failure, perform the following operations:

1. Remove the compressor.

2. Remove the receiver-dehydrator or expansion tube and discard the unit.

3. Flush the condenser to remove foreign material which has been pumped into it.

4. Disconnect the line at the evaporator core inlet or inlet line to the expansion valve.

Inspect the expansion tube or inlet screen of the expansion valve for the presence of metal chips or other foreign material. If the tube or screen is plugged, replace it. Reconnect the line to the evaporator core or expansion valve.

5. Install the replacement compressor.

6. Add the necessary quantity of oil to the system. Remember to add the one ounce for the new receiver-dehydrator.

7. Evacuate, charge and check system.

## REFRIGERANT LINE CONNECTIONS

### "O" RINGS

Always replace the "O" ring when a connection has been broken. When replacing the "O" ring, first dip it in clean refrigeration oil. Always use a backing wrench on "O" ring fittings to prevent the pipe from twisting and damaging the "O" ring. Do not over-tighten. Correct torque specifications are as follows:

**CAUTION:** *Where steel to aluminum connections are being made, use torque for aluminum tubing.*

Metal Tube O.D.	Thread and Fitting Size	Steel Tubing Torque*	Alum. Tubing Torque*
1/4	7/16	13	6
3/8	5/8	33	12



Metal Tube O.D.	Thread and Fitting Size	Steel Tubing Torque*	Alum. Tubing Torque*
1/2	3/4	33	12
5/8	7/8	33	20
3/4	1-1/16	33	25

\* Foot Pounds

### HOSE CLAMPS

When hose clamp connections are encountered, special procedures are necessary for both removal and installation.

#### Removal

1. Carefully, with a sharp knife, make an angle cut in the hose as shown in Figure 27. This should loosen the hose so that it may be worked off the fitting.

2. Cut off slit end of hose.

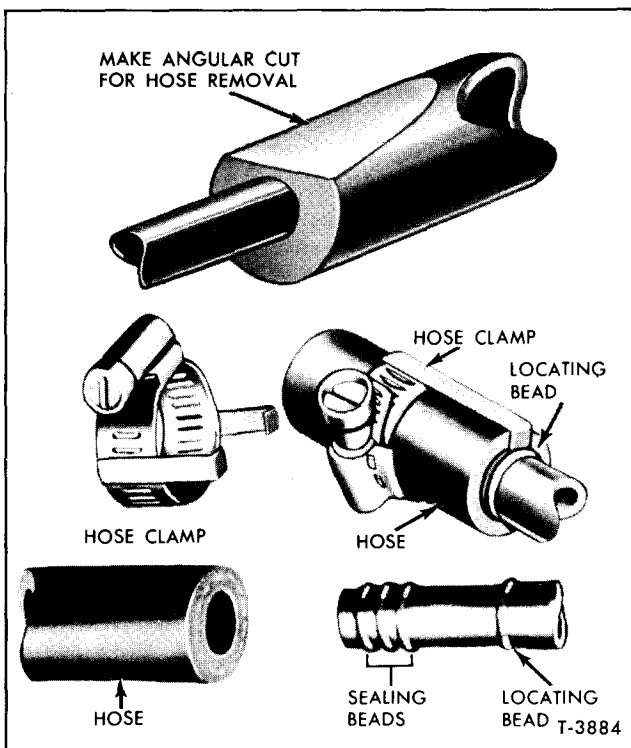

Figure 27-Hose Clamp Connections

**CAUTION:** Use only approved refrigeration hose. Never use heater hose. Use extreme care not to nick or score the sealing beads when cutting off the hose. Cutting the hose lengthwise may result in this problem.

#### Installation

1. Coat tube and hose with clean refrigeration oil.

2. Carefully insert hose over the three beads on the fitting and down as far as the fourth, or locating bead. Hose must butt against this fourth bead.

**CAUTION:** Use no sealer of any kind.

3. Install clamps on hose, hooking the locating arms over the cut end of the hose.

4. Tighten the hose clamp screw to 35-42 in. lbs. torque. **DO NOT RETORQUE.** The clamp screw torque will normally decrease as the hose conforms to the force of the clamp. The screw should be retorqued only if its torque falls below 10 in. lbs. In this case, retorque to 20-25 in. lbs. Further tightening may damage the hose.

### REPAIR OF REFRIGERANT LEAKS

Any refrigerant leaks found in the system should be repaired in the manner given below:

#### LEAKS AT "O" RING CONNECTION

1. Check the torque on the fitting and, if too loose, tighten to the proper torque. Always use a backing wrench to prevent twisting and damage to the "O" ring. Do not overtighten. Again leak test the joint.

2. If the leak is still present, discharge the refrigerant from the system as described under "Evacuating and Charging Procedures."

3. Inspect the "O" ring and the fitting and replace if damaged in any way. Coat the new "O" ring with clean refrigeration oil and install carefully.

4. Retorque the fitting, using a backing wrench.

5. Evacuate, charge and check the system.

#### LEAKS AT HOSE CLAMP CONNECTION

1. Check the tightness of the clamp itself and tighten if necessary. Recheck for leak.

2. If leak has not been corrected, discharge the system and loosen clamp and remove hose from connection. Inspect condition of hose and connector. Replace scored or damaged parts.

3. Dip end of new hose in clean refrigeration oil and carefully reinstall over connector. Never push end of hose beyond the locating bead. Properly torque the clamp.

4. Evacuate, charge and check the system.

## COMPRESSOR LEAKS

If leaks are located around the compressor shaft seal or shell, replacement of necessary seals should be made.

**NOTE:** A slight amount of oil leakage past the compressor front seal is considered normal.

## REFRIGERANT HOSE FAILURE

After a leak or rupture has occurred in a refrigerant hose, or if a fitting has loosened and caused a considerable loss of refrigerant and oil, the entire system should be flushed and recharged after repairs have been made.

Because of the length of the hoses on these systems, hose leaks may be repaired using the following procedure:

1. Locate the leak.
2. Discharge the system.

3. Cut out the leaking portion of the hose, making sure that all of the failed portion is removed. If only a very small portion of the hose was removed, it may be possible to splice the two ends together, using a special hose connector and two hose clamps. If several inches of hose must be removed, a new piece of hose should be spliced in using two connectors and four hose clamps. Dip the ends of the hoses in clean refrigeration oil before installing the hoses onto the connector. Never push the end of the hose beyond the locating bead of the connector. Torque the clamp to 35-42 in. lbs.

**NOTE:** Be sure to replace the hose in the body in the same manner as when removed. If the hose protective grommets are badly mutilated, they should be replaced.

4. Evacuate, charge and check the system.

## COMPRESSOR

### REMOVAL

1. Purge the refrigerant from the system.
2. Remove engine cover to gain access to engine components
3. Remove connector attaching bolt and hose connector (figure 28). Seal connector outlets.
4. Disconnect electrical lead to clutch actuating coil (figure 28).
5. Disconnect the hose holding clamp at the clutch pulley shield.
6. Loosen brace and pivot bolts and detach belt.
7. Remove the nuts and bolts attaching the compressor brackets to the mounting bracket.
8. Remove compressor and attaching brackets and shield by sliding rearward and dropping out bottom. Be sure compressor is removed with attaching brackets as shown in Figure 29.
9. Before beginning any compressor disassembly, drain and measure oil in the compressor. Check for evidence of contamination to determine if remainder of system requires servicing.

### INSTALLATION

1. If oil previously drained from the compressor upon removal shows no evidence of contamination, replace a like amount of fresh refrigeration oil into

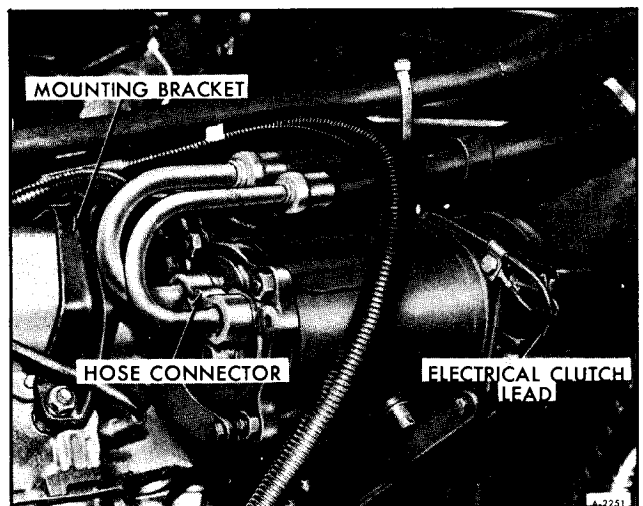

Figure 28-Compressor Installation

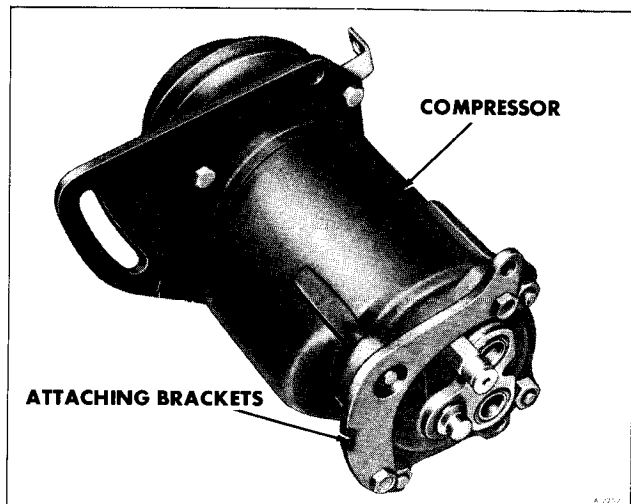

Figure 29 –Compressor Removed From Vehicle

the compressor before reinstallation. If it was necessary to service the entire system because of excessive contamination in the oil removed, install a full charge of fresh refrigeration oil into the compressor.

2. Position compressor on the mounting bracket and install all nuts, bolts and lock washers.

3. Install the connector assembly to the compressor rear head, using new “O” rings coated with clean refrigeration oil.

4. Connect the electrical lead to the coil and install and adjust compressor belt.

5. Evacuate, charge and check the system.

**IMPORTANT:** Adjust compressor belt, using belt tension gauge J-23600 or other suitable gauge. Tension should be within 70-80 lbs. (used belt), or 110-140 lbs. (new belt).

## COMPRESSOR FAILURE

If the compressor has failed mechanically to the extent that metal chips and shavings are found in it, the system should be checked for foreign material and cleaned as described under Foreign Material in the System.

## FALSE COMPRESSOR SEIZURE

Slipping or broken air conditioning drive belts and/or scored clutch surfaces may be experienced on initial start up of an air conditioning compressor after an extended period of storage or non-operation

of the compressor. This would indicate a seized compressor; however, an overhaul or replacement of the compressor may not be necessary.

During extended periods of non-operation, changes in temperature cause the refrigerant in the air conditioning compressor to expand and contract. During this movement, lubricating oil carried by the refrigerant tends to migrate from highly polished surfaces in the compressor such as the ball seats and wobble plate. Without lubricating oil at these polished surfaces, they “wring” together and appear to be seized.

Before the time and expense of an overhaul is invested, use the following check to determine if the compressor is actually seized. With a wrench on the compressor shaft lock nut or Spanner Wrench J-9403 on the clutch drive plate, “rock” the shaft in the opposite direction of normal rotation. After the compressor is broken loose, “rock” the shaft back and forth. This should be sufficient to return lubricating oil to the “wring” surfaces and allow the compressor shaft to be turned by hand. Once the compressor turns freely, rotate the compressor at least three complete turns. Start the engine and operate the compressor for a minimum of one minute.

This procedure will not affect a compressor that is actually seized but should be attempted before overhauling a compressor known to be idle for a month or longer.

## COLLISION PROCEDURE-ALL SYSTEMS

Whenever a vehicle equipped with an air conditioning unit is involved in a collision or wreck, it should be inspected as soon as possible. The extent or damage to any of all of the component parts and the length of time the system has been exposed to the atmosphere will determine the replacement of parts and processing that will be required. The greater the length of time of exposure to the atmosphere, the greater will have been the chances for air, moisture and dirt to have entered and damaged the system. Every case may be entirely different so it is not possible to establish a hard and fast procedure to follow each time. Good judgment must be used to determine what steps should be taken in each specific case.

The following procedure is presented as a guide for use when inspecting a damaged vehicle equipped with air conditioning.

1. Remove the drive belt.

2. Visually inspect the condenser, receiver-dehydrator, compressor, mounting brackets, conditioning

unit, all connecting lines and all controls to determine the extent and nature of the damage.

a. No repairs, such as soldering, welding or brazing, should be attempted on the condenser because of its construction. If the vapor passages in the horizontal tubes or return bends or manifolds have been damaged in any way, the condenser should be replaced with a new one.

b. The receiver-dehydrator should be replaced if there is any evidence of its having sustained either internal damage or a fracture at any of the lines or welded joints or if the system has been exposed to the atmosphere for an undetermined period of time.

c. Examine the compressor for any visible external damage.

d. The evaporator should be examined for damage and, if necessary, removed or replaced or the entire unit processed where damaged or exposed to the atmosphere.

e. All connecting lines and flexible hoses should be examined throughout their entire length for damage. If damaged in any manner, replace with new lines.

f. Check all controls and connecting wires for damage and replace with new parts where needed.

g. Check the clutch pulley for proper operation and freedom from damage.

3. Install Charging Station.

4. Purge the system.

5. Remove the compressor from mounting and remove the oil test fitting.

6. Pour out the oil into a clean glass container and examine it for any foreign substance such as dirt, water, metal particles, etc. If any of these are present, the compressor, expansion tube, and receiver-dehydrator should be replaced and the other system components should be flushed with liquid refrigerant.

7. If the oil is clean and free of any harmful substance, replace oil with Frigidaire 525 Viscosity Oil, or equivalent.

**NOTE:** If the system components have been replaced or flushed, replace the full charge of oil. If not, add no more fresh oil than was drained in Step 6.

8. Charge up the compressor to cylinder or can pressure. Leak test the compressor seals prior to installation of compressor.

9. Reinstall the compressor and evacuate the system by following the Evacuating Procedure.

10. Introduce R-12 vapor at cylinder (room) temperature and pressure.

11. Leak test all fittings and connections and give particular attention to a leak test at the compressor shaft seal if compressor has not been leak tested on the bench.

12. Complete system processing and charge system.

## CONDENSER

### REPLACEMENT

1. Disconnect battery ground cables.

2. Purge the system of refrigerant.

3. Remove grill assembly.

4. Disconnect the condenser inlet and outlet lines. Cap or plug all open connections at once.

5. Remove the receiver-dehydrator and its holding straps (See figure 13).

6. Remove the condenser to radiator mounting screws (figure 30).

7. Remove the condenser assembly by pulling it forward and then lowering it from the vehicle through grille.

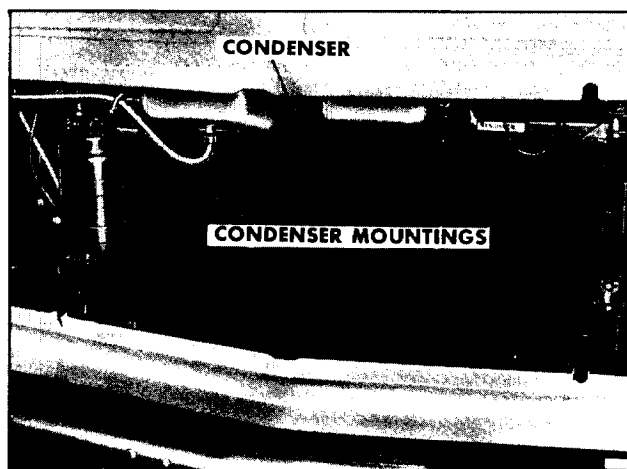

Figure 30—Condenser Mounting

8. To install a new condenser, reverse Steps 1-6 above. Add one fluid ounce of clean refrigeration oil to a new condenser.

**NOTE:** Use new "O" rings, coated with clean refrigeration oil, when connecting all refrigerant lines.

9. Evacuate, charge and check the system.

## RECEIVER-DEHYDRATOR

### REPLACEMENT

1. Disconnect the inlet and outlet lines being sure to use a wrench on the square portion of the receiver dehydrator for support. This will prevent twisting and possible breaking of the aluminum lines (See figure 31).

2. Loosen holding straps and slide out receiver-dehydrator.

3. To install, reverse steps 1 and 2 being sure to add 1 ounce of clean refrigeration oil and install new "O" rings.

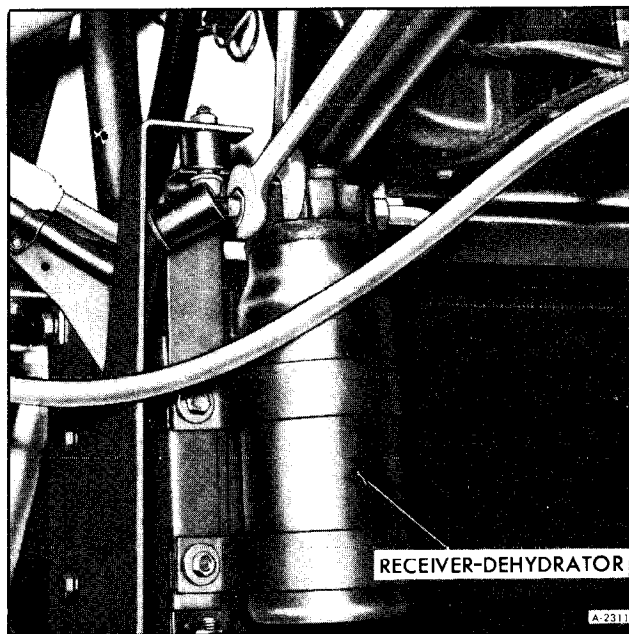

Figure 31-Disconnecting Lines to Receiver-Dehydrator

## BLOWER ASSEMBLY (FIGURE 32) REPLACEMENT

1. Disconnect the battery ground cables.

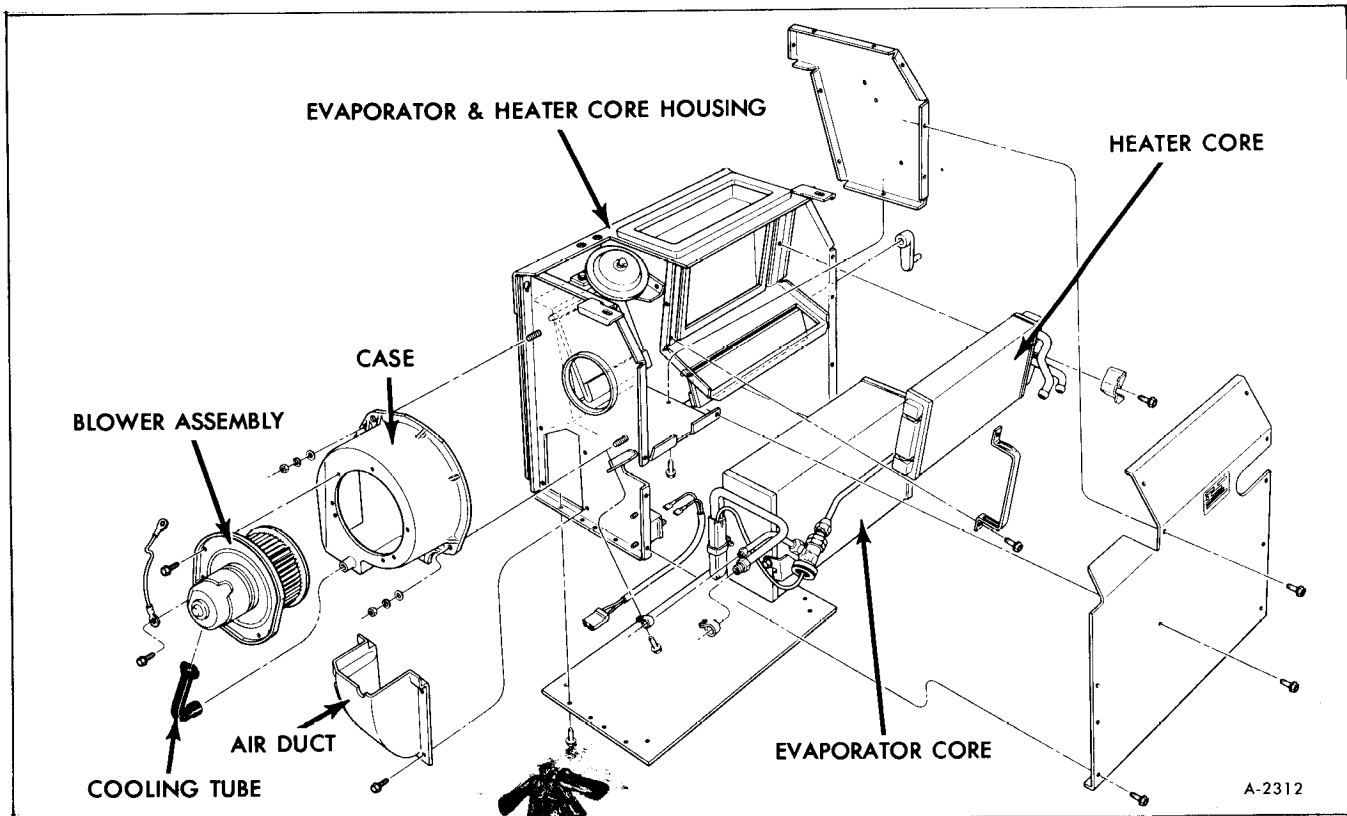

Figure 32-Evaporator and Heater Housing Components

2. Disconnect the blower motor lead and ground wires.
3. Disconnect the blower motor cooling tube.
4. Remove the blower to case attaching screws and remove the blower assembly. Pry the blower flange away from the case carefully if the sealer acts as an adhesive.
5. Remove the nut attaching the blower wheel to the motor shaft and separate the assemblies.
6. To install, reverse Steps 1-5 above; replace sealer as necessary.

## EVAPORATOR AND HEATER CORE ASSEMBLY

### REPLACEMENT (FIGURE 14)

1. Purge system.
2. Disconnect air conditioning lines from evaporator.
3. Disconnect heater hoses from heater core.
4. Disconnect all vacuum lines, wires and cables connected to the box assembly.
5. Remove windshield washer reservoir.
6. Remove coolant recovery reservoir and bracket.
7. Disconnect windshield wiper arms.
8. Remove attaching bolts and remove through front access door.
9. To install, reverse steps 1 through 8.

## EVAPORATOR CORE AND EXPANSION VALVE

### REPLACEMENT (FIGURE 14)

**CAUTION:** *When repair or replacement of the evaporator core or expansion valve is necessary, be sure to remove both as the method of attaching the sensing tube to the evaporator outlet line will cause it to be damaged if you try to remove only one item.*

1. Purge the system of refrigerant.
  2. Remove all attaching items to the evaporator and heater core assembly necessary to remove the assembly front cover.
  3. Remove assembly front cover exposing evaporator core, expansion valve, thermostat switch, heater core and selector door.
- NOTE:** After removing all the cover screws, be sure to remove the cover retaining clip.
4. Remove evaporator inlet and outlet hoses.
  5. Carefully remove thermostatic switch probe from front of evaporator held by plastic clips. Do not bend this tube excessively.
  6. Remove four attaching screws and gently pull out evaporator core.
  7. When core and expansion valve are removed the expansion valve may easily be removed without damaging the sensing tube.
  8. To install, reverse steps 1-7.

## VACUUM TANK

The vacuum tank is mounted to the right side of the evaporator and heater core assembly (See figure 14).

### REPLACEMENT

1. Disconnect the vacuum lines at the tank.
2. Remove the tank to dash panel screws and remove the tank.
3. To install, reverse Steps 1 and 2 above.

## BLOWER MOTOR RESISTOR

The blower motor resistor is located opposite the blower side of the blower-evaporator case (figure 14).

### REPLACEMENT

1. Disconnect battery ground cables and the wiring harness at the resistor.

2. Remove the resistor to case attaching screws and remove the resistor.

3. Place the new resistor in position and install the attaching screws.

4. Connect the resistor wiring harness and battery cables.

## THERMOSTATIC SWITCH (FIGURE 14)

The thermostatic switch is mounted to the blower side of the blower-evaporator case. The switch sensing capillary extends across the evaporator core.

### REPLACEMENT

1. Disconnect the battery ground cables.

2. Disconnect the wiring harness at the switch.

3. Remove the switch to case screws and remove the switch carefully so as not to damage the capillary tube.

**NOTE:** Note capillary tube position across the core so that the capillary may be reinstalled in the same position.

4. Place the new switch in position, installing the capillary in the core in the same manner as at switch removal.

5. Install the switch mounting screws, connect the wiring harness and the battery ground cables.

## DISCHARGE PRESSURE SWITCH

The discharge pressure switch is located in the condenser to evaporator line (figure 16).

### REPLACEMENT

1. Disconnect the battery ground cables.

2. Purge the system of refrigerant.

3. Disconnect the wiring harness at the switch.

4. Remove the switch from the refrigerant line.

5. To install, reverse Steps 1-4 above.

**NOTE:** Be sure to use new "O" rings, coated with clean refrigeration oil, when installing the switch.

6. Evacuate charge and check system operation.

## FUSE

A 25 amp fuse, located in the junction block protects the entire air conditioning system except for the blower when operating at HI.

## BLOWER MOTOR RELAY

The blower motor relay is located on the firewall on the blower side of the blower-evaporator case (figure 18).

### REPLACEMENT

1. Disconnect battery ground cables and the wiring harness at the relay.

2. Remove the relay to case attaching screws and remove the relay.

3. Place the new relay in position and drive the mounting screws.

4. Connect the relay wiring harness and battery ground cables.

## CONTROL ASSEMBLY (FIGURE 21)

### REPLACEMENT

1. Disconnect the battery ground cables.

2. Remove instrument panel bezel.

**NOTE:** For details on instrument panel bezel removal refer to "Instrument Panel Bezel Replacement" contained in CHASSIS ELECTRICAL (SECTION 12) of this manual.

3. Remove four screws holding control assembly to instrument panel (figure 33).

4. Pull panel forward to gain access to rear of control assembly.

**CAUTION:** *Be careful not to kink the bowden cable.*

5. Disconnect the bowden cable, vacuum harness and electrical harness at the control.

6. If a new unit is being installed, transfer all electrical switches and vacuum valves to the new control.

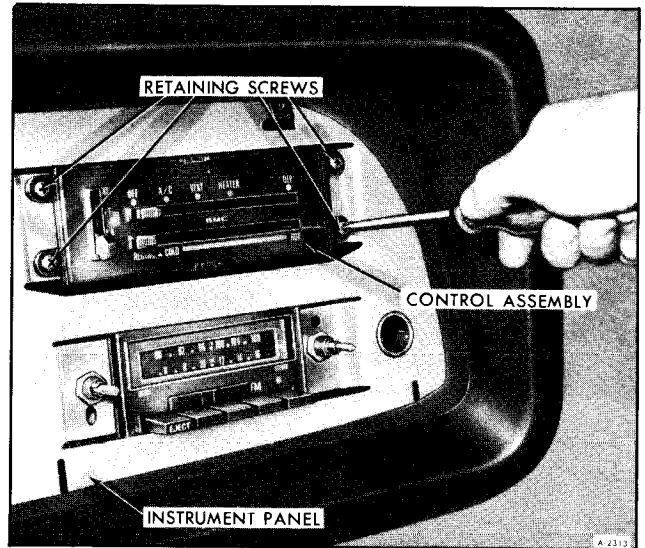

Figure 33—Removing Control Assembly

3. Installation of switch is the reverse of Steps 1 and 2.

## BLOWER SWITCH (FIGURE 20)

### REPLACEMENT

1. Remove the control assembly as described above.

2. Disconnect wires to switch and remove two attaching screws.

# COMPRESSOR MINOR OVERHAUL PROCEDURES

The following operations to the hub and drive plate, pulley and bearing, and coil housing are covered as "Minor" because they may be performed without first purging the system or removing the compressor from the vehicle. The shaft seal assembly may also be serviced without removing the compressor from the vehicle, but this operation is covered later in this Manual as a "Compressor Major Overhaul Procedure" because the system must first be purged of refrigerant.

Illustrations used in describing these operations show the compressor removed from the vehicle to more clearly illustrate the various operations.

## HUB AND DRIVE PLATE

### REMOVAL

1. If disassembly is being performed on a bench, mount support bracket (J-9396) in a vise and attach the compressor to the bracket.

2. Using drive plate holding tool (J-9403) and socket J-9399, remove the lock nut from the shaft (figure 34). Discard lock nut.

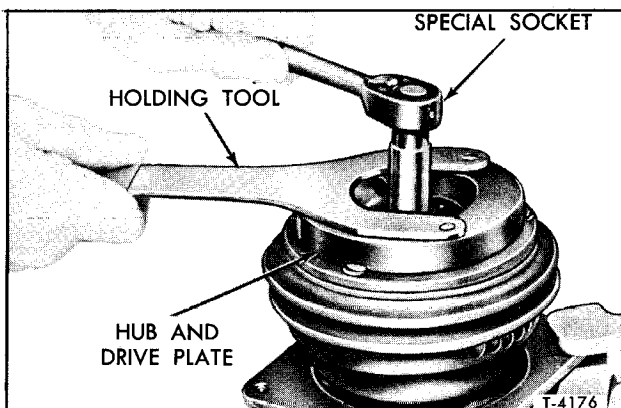

Figure 34—Removing Shaft Locknut

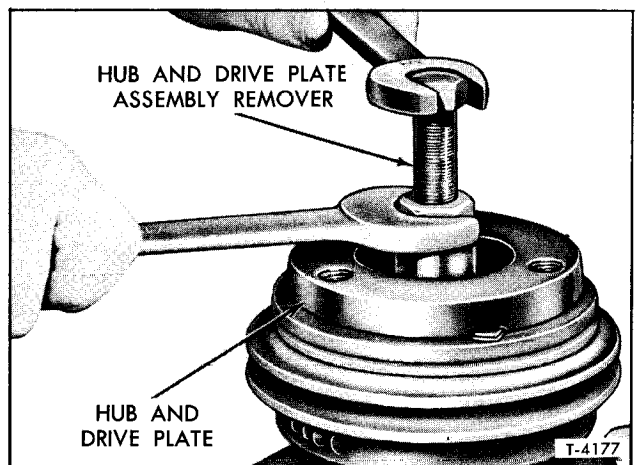
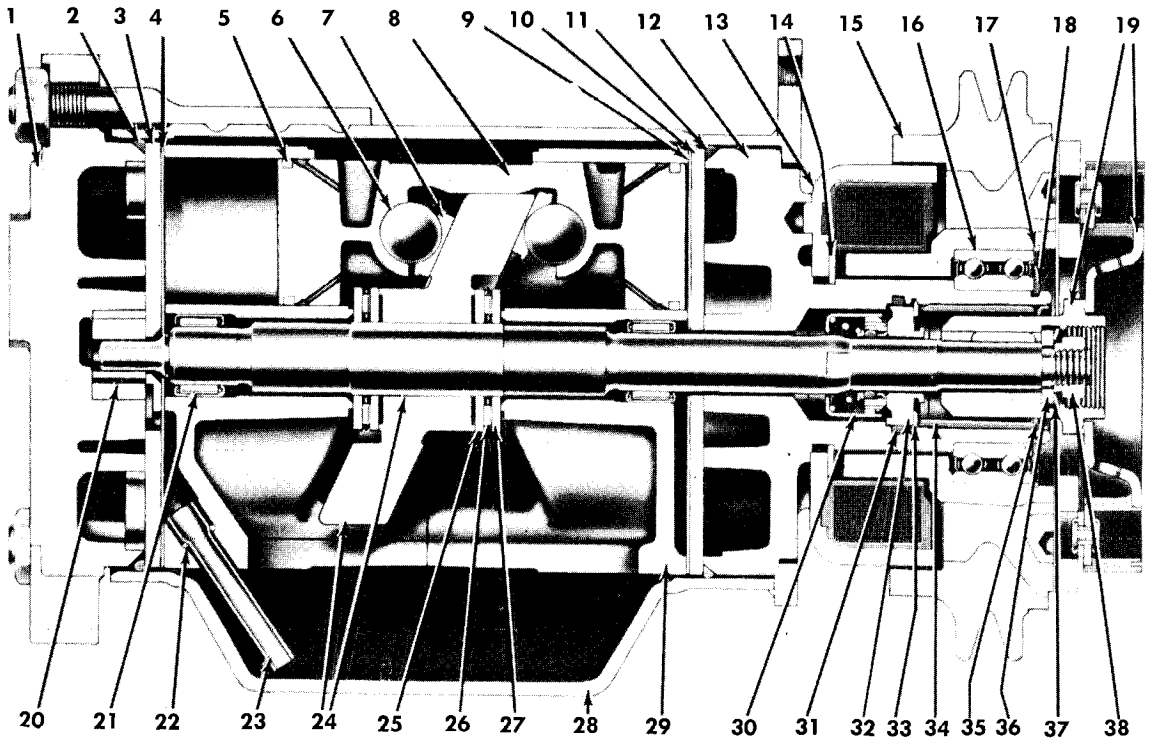

Figure 35—Removing Hub and Drive Plate Assembly





- |  |  |
|--|--|
| 1 Rear Head                            | 20 Oil Pump Gears                      |
| 2 Rear Head to Shell O-ring            | 21 Mainshaft Bearing (Rear)            |
| 3 Rear Discharge Valve Plate           | 22 Oil Inlet Tube O-ring               |
| 4 Rear Suction Reed Plate              | 23 Oil Inlet Tube                      |
| 5 Piston Ring                          | 24 Wobble Plate and Mainshaft Assembly |
| 6 Piston Drive Ball                    | 25 Thrust Race                         |
| 7 Ball Seat                            | 26 Thrust Bearing                      |
| 8 Piston                               | 27 Thrust Race                         |
| 9 Front Suction Reed Plate             | 28 Compressor Shell                    |
| 10 Front Discharge Valve Plate         | 29 Cylinder Assembly                   |
| 11 Front Head to Shell O-ring          | 30 Shaft Seal                          |
| 12 Front Head                          | 31 Shaft Seal Seat O-ring              |
| 13 Coil and Housing Assembly           | 32 Shaft Seal Seat                     |
| 14 Coil Housing Retainer Ring          | 33 Shaft Seal Seat Retainer Ring       |
| 15 Pulley and Bearing Assembly         | 34 Felt Sleeve                         |
| 16 Pulley Bearing                      | 35 Felt Sleeve Retainer                |
| 17 Pulley Bearing Retainer Ring        | 36 Spacer                              |
| 18 Pulley and Bearing Retainer Ring    | 37 Clutch Hub Retainer Ring            |
| 19 Clutch Hub and Drive Plate Assembly | 38 Shaft Nut                           |

T-4175

Figure 36-Compressor Cross Sectional View

3. Tool (J-9401) may now be used to remove the hub and drive plate assembly (refer to figure 35).

**NOTE:** Carefully snug tool into place with wrench to insure engagement with threads.

4. Use snap ring pliers (J-5403) to remove the retainer ring (Item 37, figure 36). Then remove the hub spacer.

## INSPECTION

If the frictional surface shows signs of damage due to excessive heat, the hub and drive plate and the pulley should be replaced. Check further for the underlying cause of the damage; i.e., low coil voltage or binding of the compressor internal mechanism.

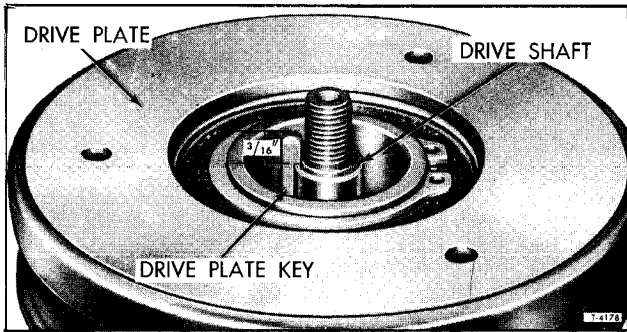

Figure 37-Drive Plate Installed In Keyway

## INSTALLATION

**NOTE:** When hub and drive plate assembly is ready for installation, clean its frictional face with a suitable cleaner.

1. Insert the square hub and drive plate key into the keyway in the drive shaft allowing it to project approximately  $3/16$ " out of the end of the keyway (figure 37).

2. Line up the key in the shaft with the keyway in the hub.

3. Using tool (J-9480-01, figure 38), install the hub and drive plate assembly. Pull the assembly onto the shaft until there is approximately  $3/32$ " space between the frictional surfaces of the drive plate and pulley. (A ZERO thrust race is approximately  $3/32$ " thickness and may be used to roughly gauge this operation.)

**NOTE:** Use tool (J-9403) to hold hub and drive plate if necessary.

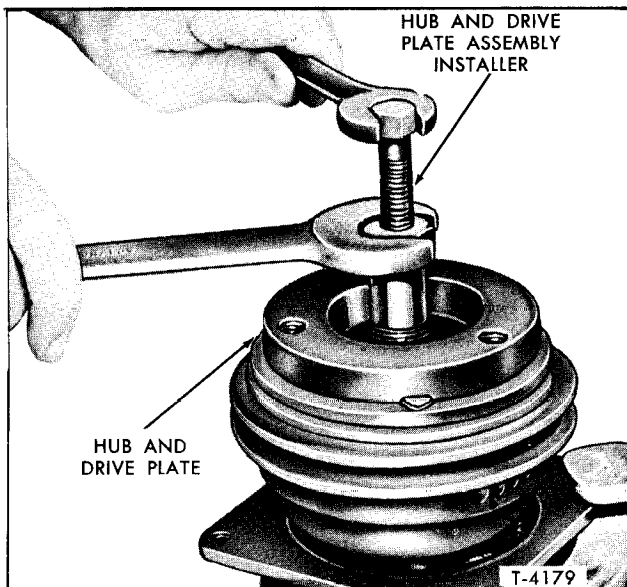

Figure 38-Installing Hub and Drive Plate Assembly

4. Install the hub spacer washer and, using snap ring pliers (J-5403), install the retainer ring (Item 37, figure 36), convex side of ring facing washer.

5. Use tools (J-9399 and J-9403) to install a new lock nut. Tighten the nut to 14-26 foot-pounds torque. Air gap between the frictional faces should now be  $.022$ " to  $.057$ ".

**NOTE:** The shoulder or circular projection on the lock nut must face toward retainer ring.

6. The pulley should now rotate freely.

**CAUTION:** *Never pound or drive the hub and drive plate into position. Always use the proper tools when removing or replacing clutch parts. Failure to do so may result in serious internal compressor damage.*

7. Operate the refrigeration system and rapidly cycle the clutch (by turning the air conditioning off and on at least 20 times at approximately one second intervals) to seat the mating parts of the clutch.

## PULLEY AND BEARING ASSEMBLY

### REMOVAL

1. Remove the hub and drive plate assembly.

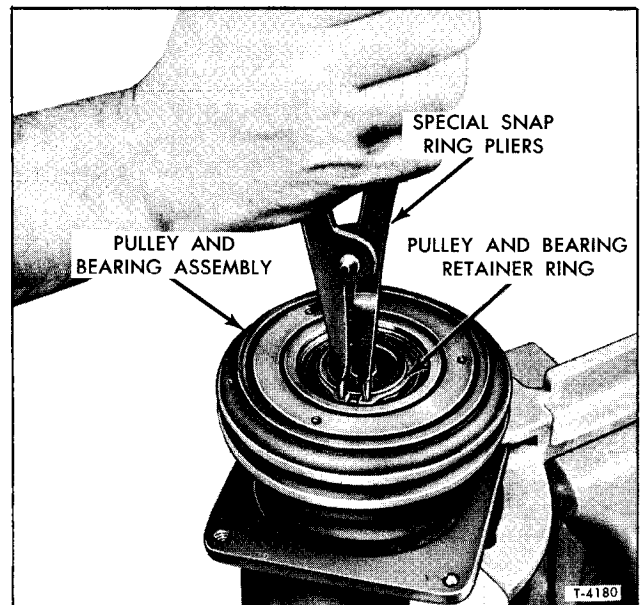

Figure 39-Removing Pulley and Bearing Assembly Retaining Ring

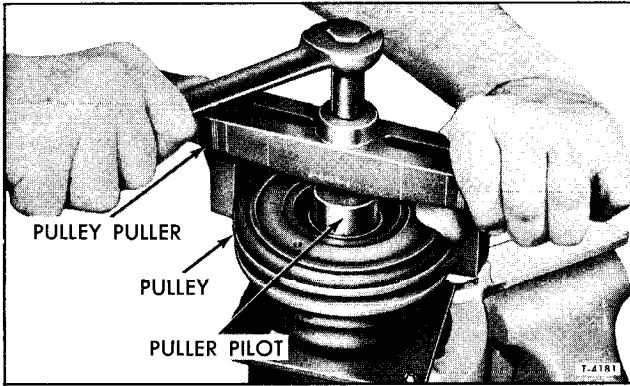

Figure 40—Removing Pulley

2. Using snap ring pliers (J-6435), remove the pulley and bearing retainer ring (figure 39).
3. Remove shaft key.
4. Place puller pilot (J-9395) over the compressor shaft and pull off the pulley assembly using (J-8433) pulley puller (figure 40).

**INSPECTION**

Check the appearance of the pulley and bearing assembly. If the frictional surface of the pulley indicates excessive grooving due to slippage, both the pulley and the clutch hub and drive plate assembly should be replaced. The frictional surfaces of the bearing to be used should be cleaned with a suitable solvent before reinstallation.

**BEARING REPLACEMENT**

1. With the pulley and bearing assembly removed from the compressor, use a sharp pointed instrument to remove the wire retainer ring.
- CAUTION:** *If the bearing is to be reused, be careful not to slip and damage the seal.*
2. From the rear of the pulley, press or drive bearing out of pulley using tool (J-9398) and handle (J-8092).
  3. From the front of the pulley and using tool (J-9481) with handle (J-8092), press or drive the new bearing into the pulley.

**INSTALLATION**

1. Using tool (J-9481), press or drive the pulley and bearing assembly onto the compressor neck. The pulley should now rotate freely.

2. Install retainer ring using snap ring pliers (J-6435).
3. Replace the hub and drive plate assembly. Use proper tools. **DO NOT** drive or pound on the hub assembly.
4. Install the wire bearing retainer ring.

**COIL HOUSING ASSEMBLY**

**REMOVAL**

1. Remove the hub and drive plate assembly, the pulley and bearing assembly, and electrical connector.
2. Scribe the location of the coil housing to the compressor body. This operation is to insure that the electrical terminals will be reassembled in the same position.
3. Using snap ring pliers (J-6435), remove the coil housing retainer ring (figure 41).
4. Remove the coil housing assembly.

**INSPECTION**

Check coil for loose connectors or cracked insu-

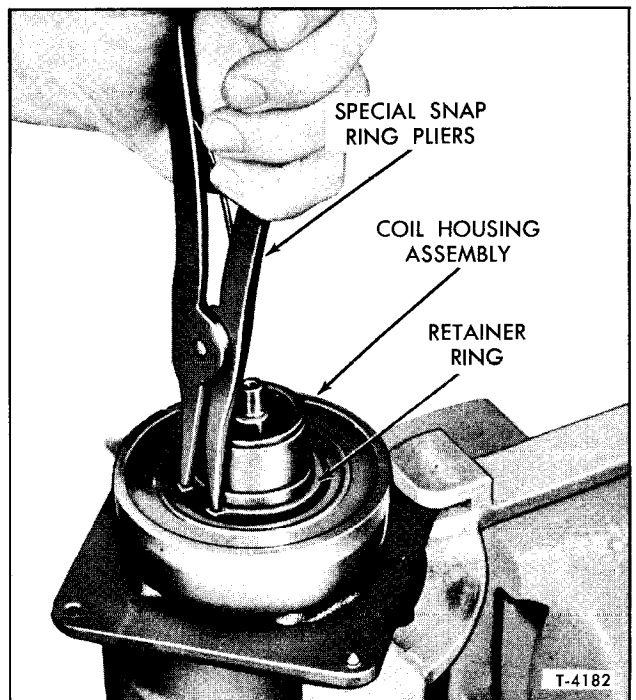

Figure 41—Removing Coil Housing Retainer Ring

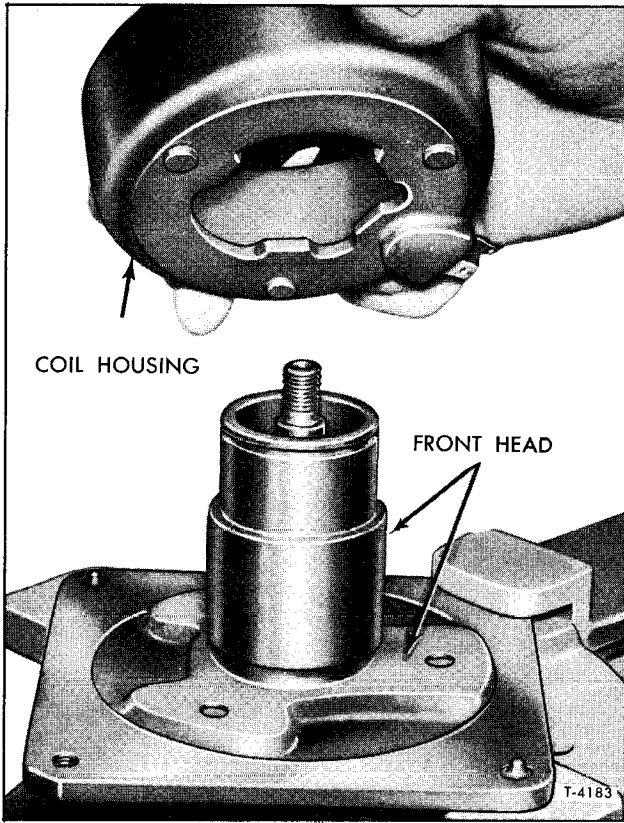

Figure 42—Installing Coil Housing

lation. Amperage should not be more than 3.2 amps at 12 volts D.C. at room temperature.

## INSTALLATION

1. Rotate the coil housing to the correct position as indicated by the scribe marks and the location of the electrical terminals and fit into place (figure 42).

2. Use snap ring pliers (J-6435) to install retainer ring.

**NOTE:** Install flat surface of the retainer ring facing the coil housing.

3. Replace the pulley and bearing assembly and the hub-and drive plate assembly. **DO NOT** drive or pound on the hub assembly.

4. If the compressor is installed in the vehicle, connect the electrical connections.

# COMPRESSOR MAJOR OVERHAUL PROCEDURES

The following service procedures are considered major since the refrigeration system must be completely purged of refrigerant before proceeding and/or because major internal operating and sealing components of the compressor are being disassembled and serviced. A clean workbench, preferably covered with a sheet of clean paper, orderliness in the work area and a place for all parts being removed and replaced is of great importance as is the use of the proper service tools. Any attempt to use make-shift or inadequate equipment may result in damage and/or improper compressor operation.

These procedures are based on the use of the proper service tools and the condition that an adequate stock of service parts is available. This service parts stock should include the following:

1. Major interior mechanism assembly – ready for installation in shell as is.

2. Service cylinder assembly – front and rear halves with main bearings in place and halves dowel pinned together.

3. Standard size piston drive balls.

4. Ball seats – total of 10 sizes, including the ZERO seat.

5. Thrust races – total of 14 sizes, including the ZERO race.

6. Pistons.

7. Mainshaft bearings.

8. Thrust bearings.

9. Compressor shaft and wobble plate.

10. Suction reed valves.

11. Discharge valve plate – front and rear.

12. Seal kit – service – contains all seals and O-rings to be used each time a compressor is rebuilt.

13. Shaft seal kit.

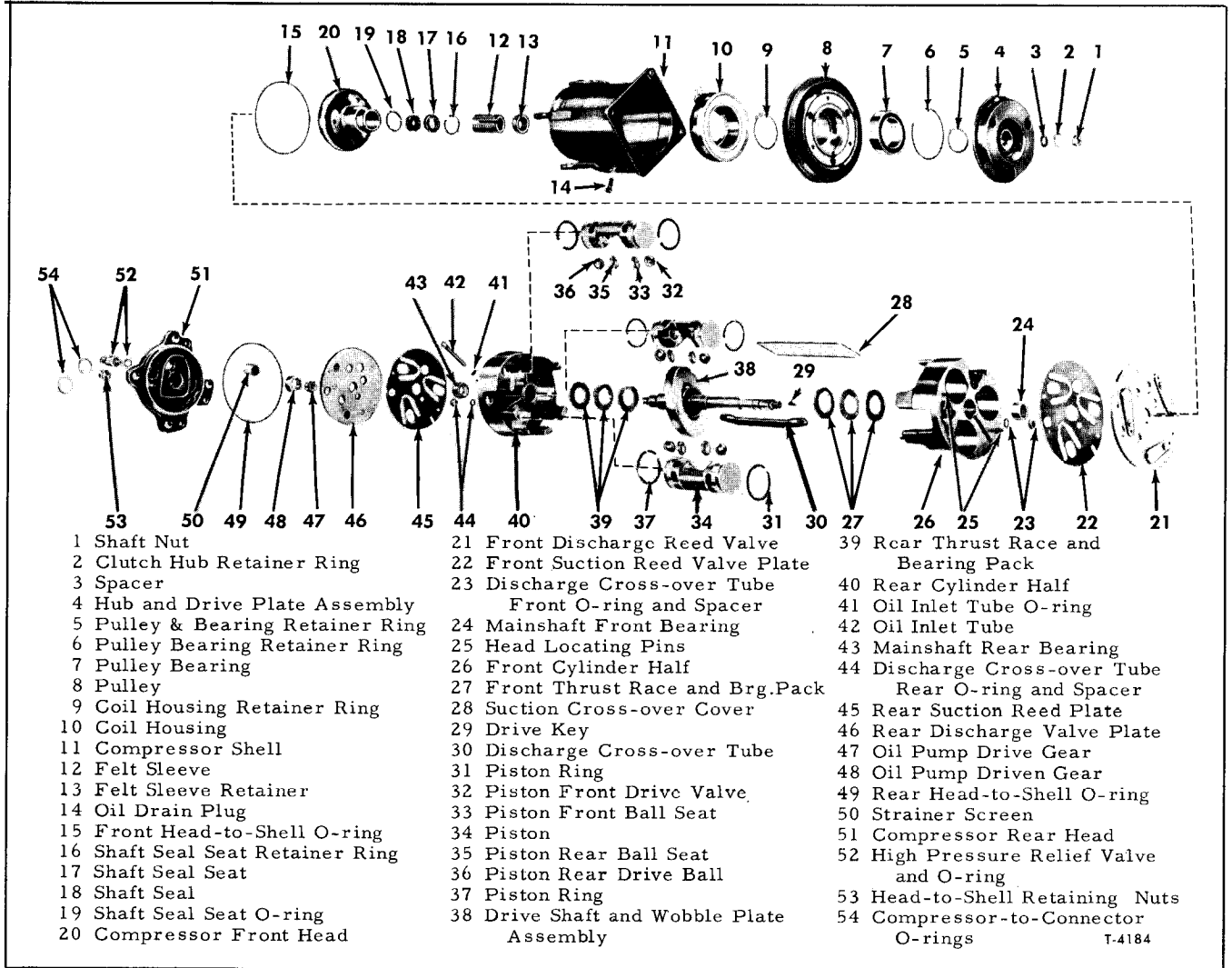

Figure 43-Exploded View of Compressor

- 14. Nuts – head to shell, and shaft.
- 15. Retainer rings – all necessary sizes.
- 16. Cylinder locator (dowel) pins.
- 17. Valve and head locator (dowel) pins.
- 18. Service discharge cross-over tube kit.

All parts required for servicing are protected by a preservation process and packaged in a manner which will eliminate the necessity of cleaning, washing or flushing of the parts. The parts can be used in the mechanism assembly just as they are removed from the service package.

Piston ball seats and shaft thrust races will be identified on the parts themselves to denote their size and dimension.

## SHAFT SEAL ASSEMBLY

When replacing the shaft seal assembly, even if the compressor remains on the vehicle during the operation, it will be necessary to purge the system of refrigerant as outlined earlier in this section.

## REMOVAL

1. After first purging the system of refrigerant, remove the clutch hub and drive plate, and the shaft key as explained previously under "Compressor Minor Overhaul Procedures."

2. Before removing the seal seat and retaining ring, thoroughly clean the area of the neck of the compressor surrounding the shaft to remove all dirt or foreign material. Pry out the felt retaining ring

and remove the felt sleeve. Remove the seal seat retaining ring using snap ring pliers (J-5403).

3. Using tool (J-23128), grasp the flange on the seal seat and lift out the seal seat (figure 45).

4. Remove the seal seat O-ring from the housing bore using tool (J-9553).

5. Engage the tabs on the seal assembly with the locking tangs on tool (J-9392) by pressing down and twisting the tool, then lift the seal out.

## INSPECTION

Check the face of the seal for nicks, gouges, or serrations. If damage of any kind is evident, replace the seal. Be extremely careful that the face of the seal which is to be installed is not scratched or damaged in any way.

Apparent seal leaks are sometimes the result of mispositioning of the wobble plate on the compressor shaft caused by improper procedures during pulley removal or pounding or dropping on the compressor shaft. Check as shown in Figure 44. If measurement is greater than shown, replace the shaft and wobble plate assembly.

## INSTALLATION

1. Engage seal onto the locking tangs of tool (J-9392) (figure 46) and with shaft seal protector tool (J-21303) installed over the end of the shaft, carefully insert the seal and tool over the end of the shaft. Turn seal to engage the flat on the shaft, then remove the tool.

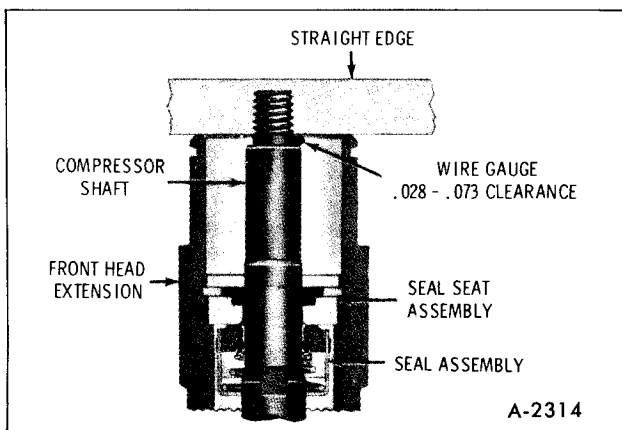

Figure 44—Checking Compressor Shaft and Seal

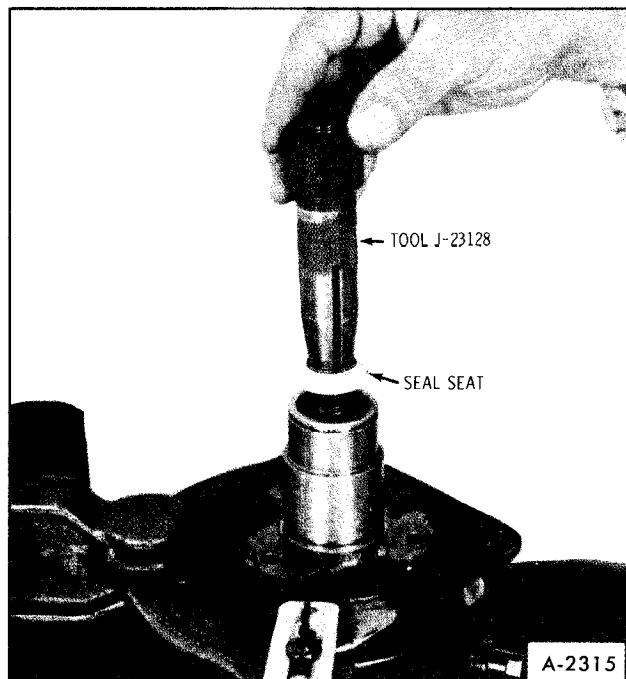

Figure 45—Removing Seal Seat

2. Coat a new O-ring and the interior of the seal cavity, shaft and seal with clean refrigeration oil, and, using tool (J-21508), install the O-ring in its groove just above the seal.

To install the O-ring, place O-ring on tool as shown in Figure 46. Insert the tool fully into the front head bore, press down the slider, twist entire tool to seat O-ring and then remove tool.

3. Using tool (J-23128), grasp the seal seat and set in place on top of the seal.

4. Using snap ring pliers (J-5403), replace the retaining ring. Tap with the palm of the hand on the barrel of tool (J-23128) to press the retainer ring into place.

**NOTE:** Install the retaining ring with the flat surface facing the seal seat.

5. Leak test the compressor as described under "Leak Testing the Compressor" in this manual.

6. Roll the felt into a cylinder and slip it into the neck of the compressor top. With a small screwdriver or similar tool, spread the felt so that the ends butt. Using tool (J-9395), tap the felt retaining ring (flange first) into the compressor neck until flush with the end.

7. Reinstall the clutch hub and drive plate.

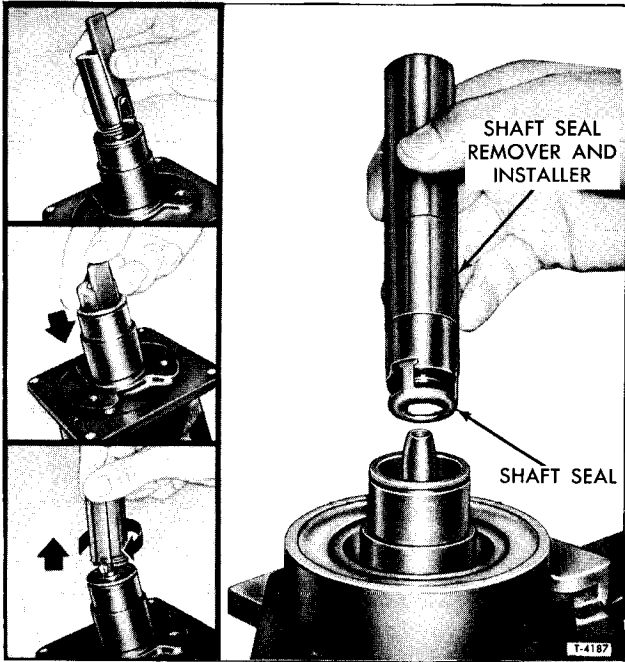

Figure 46—Installing Seal and O-Ring

8. Replace the compressor on the vehicle, if it was previously removed, and evacuate and charge the system.

### PRESSURE RELIEF VALVE

When a faulty pressure relief valve, located in the rear head casting, is encountered, the valve assembly should be removed after purging the system and a new valve and gasket installed. The entire system should then be evacuated and recharged.

## COMPRESSOR REAR HEAD AND INTERNAL MECHANISM

Service operations to the rear head or internal mechanism of the compressor should be performed with the compressor removed from the vehicle to insure that the necessary degree of cleanliness may be maintained.

**IMPORTANT:** Clean hands and a clean bench, preferably covered with clean paper, are of extreme importance.

### REAR HEAD, OIL PUMP AND VALVE ASSEMBLIES

#### Removal

1. Remove the compressor from the vehicle, drain compressor oil into a clean container, clean the

exterior of the compressor case and rear head casting with a suitable solvent and mount the compressor, rear head up, in holding fixture (J-9396) which should then be mounted securely in a vise.

2. Remove the four nuts from the shell studs.

3. Remove the rear head. Examine the teflon surface on the casting webs. If this surface is damaged by nicks or scratches, the head should be replaced.

4. Examine the suction screen in the rear head for any damage or contamination. Clean or replace the screen as necessary.

5. Remove and examine the oil pump gears. If either of the gears shows any wear or damage, replace both gears.

**NOTE:** Keep the ends of the two oil pump gears matched and position the same end toward the discharge plate upon reassembly.

6. Remove the rear head-to-shell O-ring and discard.

7. With two screwdrivers, carefully pry up on the rear discharge valve plate assembly (figure 47). Check for broken reeds or damaged seats and replace entire assembly if such is found.

**CAUTION:** Excessive force during this operation may loosen valve reed retainer rivets.

8. Carefully lift off the rear suction reed valve. Valve must be replaced if any damage is evident.

#### Installation

1. Carefully install the suction reed valve and the rear discharge valve plate over the dowel pins and ports in the cylinder assembly. Proper positioning of the reed plate may be determined by lining up the proper opening in the plate with the discharge cross-over tube opening.

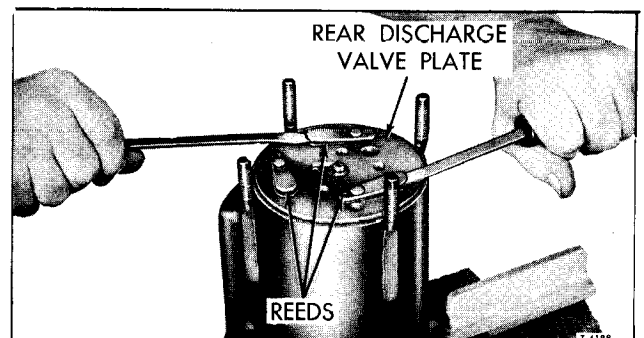

Figure 47—Removing Rear Discharge Valve Plate

2. Position the rear head casting to align with the dowel pins. The two lower mounting pads will be in alignment with the oil sump in the shell. Rotate the cylinder assembly back and forth by hand, if necessary, to permit this alignment. Remove the rear head from this trial assembly.

3. Install the inner oil pump gear over the flat on the shaft and place the outer oil pump gear over the inner gear. Position the outer gear as follows:

- a. Observe the position of the oil sump in the shell.
- b. Locate the approximate centerline of sump pump.
- c. Facing the centerline of the sump and viewing from the sump side (bottom) of the compressor, move the OUTER gear toward the right (side having the oil drain fitting) until it is at approximately 90° (3 o'clock position) from the centerline of the oil sump (figure 48).

4. Coat the head-to-shell O-ring with clean refrigeration oil and generously lubricate the area around the outer edge of the valve plate where the O-ring will be placed. Oil also the oil pump gears, valve reeds and the area where the teflon gasket will contact the valve plate.

5. Install the head-to-shell O-ring.

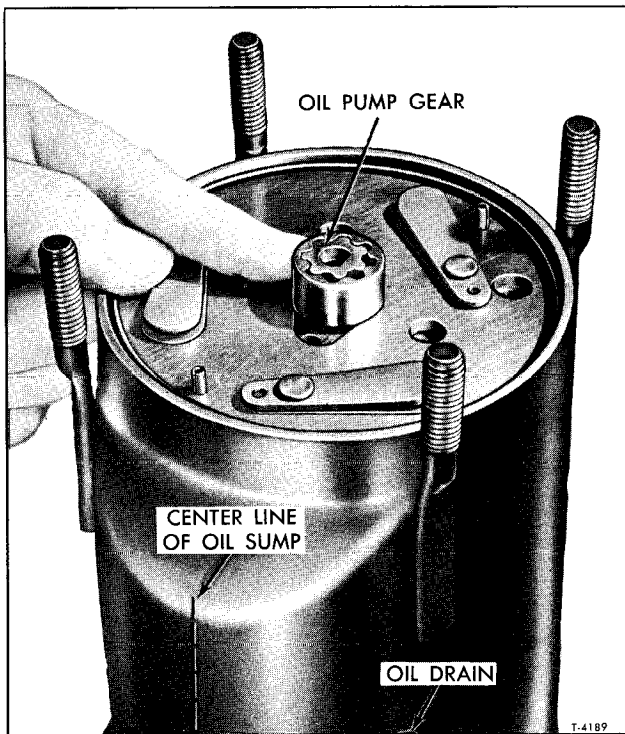

Figure 48—Proper Oil Pump Gear Positioning

6. Be sure that the suction screen is properly positioned in the rear head, then assemble the rear head to the compressor shell being careful not to damage the teflon gasket.

**CAUTION:** *Be sure head does not bind against oil pump gears when being installed.*

7. Install new nuts to the threaded shell studs and tighten to 19-25 foot-pounds torque.

8. Leak test the compressor as outlined under "Leak Testing the Compressor" in this manual.

9. Install compressor in the vehicle.

## MAJOR INTERNAL MECHANISM

The clutch hub and drive plate assembly, drive key, pulley and coil housing should be removed before proceeding with the following compressor disassembly.

### Removal From Shell

1. Remove the rear head, discharge plate and suction reed valve from the compressor as outlined previously under "Rear Head Oil Pump and Valve Assemblies."

2. Remove the oil inlet tube and O-ring with tool (J-5139) as shown in Figure 49.

3. Carefully lay the compressor shell on its side and slide out interior mechanism and front head assembly. Do not hammer or use undue force to

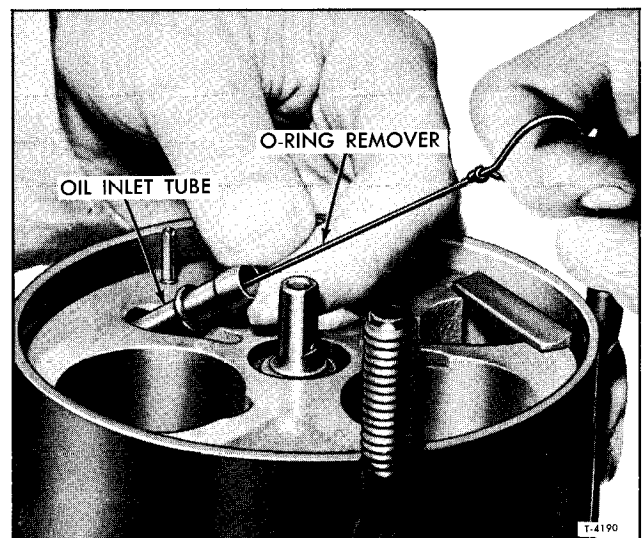

Figure 49—Removing Oil Inlet Tube and O-Ring



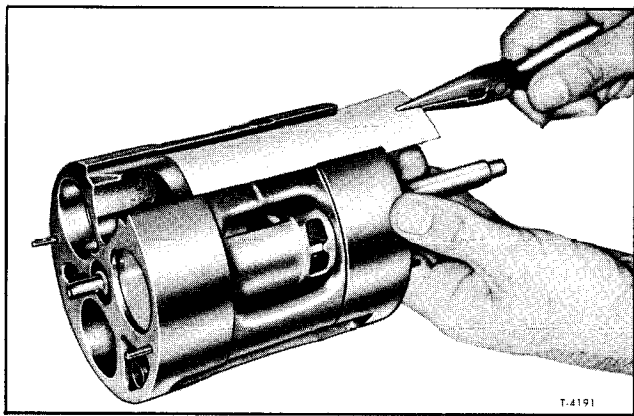

Figure 50—Removing Suction Crossover Cover

remove the mechanism; however, gentle taps on the head casting may aid in removing the assembly.

4. Remove front head casting, front discharge valve plate and suction reed valve from the mechanism. Examine parts for damage and replace if necessary. Check particularly for damage to the teflon surfaces on the front head casting webs.

5. Examine the mechanism for any obvious damage.

6. Remove the suction cross-over cover (figure 50).

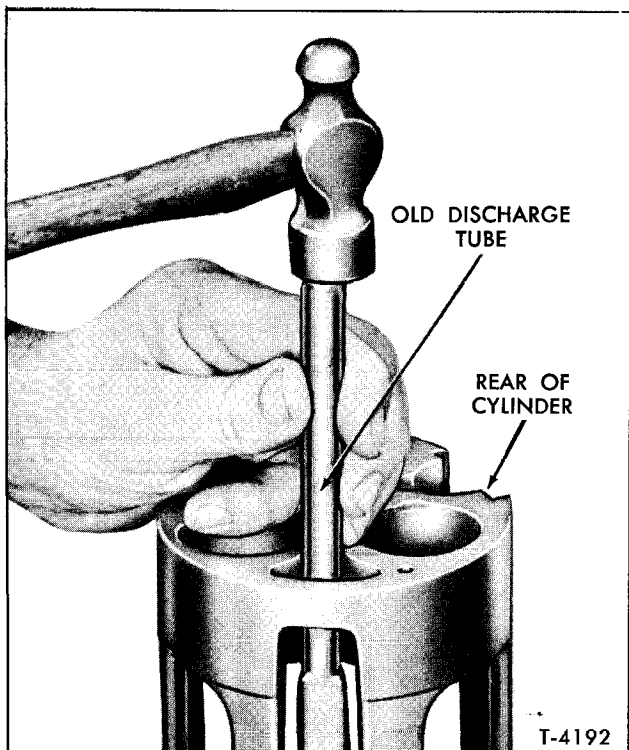

Figure 51—Unseating Discharge Crossover Tube

7. If desired, the mechanism may be assembled in checking cage (J-9397) and operated on a motor test stand, or by some other suitable means, to observe sound level and general operation. Tighten cage nuts evenly to 14-16 foot-pounds torque.

8. Remove mechanism from the cage.

**Disassembly**

If the mechanism has sustained major damage, due possibly to loss of refrigerant and/or oil, it may be necessary to replace it with a complete service interior mechanism assembly rather than to replace individual parts. If further disassembly is considered worthwhile, proceed as follows:

1. Before disassembling the cylinder and mechanism, number the pistons and cylinder locations so that all parts may be replaced in their original location. Pistons and cylinder bores may be identified by numbering them 1, 2, and 3 with a pencil.

2. Use an old discharge tube to drive discharge tube out of cylinder (figure 51). (Drive from REAR of cylinder.)

3. Drive the cylinder halves apart and free from the dowel pins and discharge crossover tube using a fiber block and mallet (figure 52). Discard the discharge cross-over tube.

**NOTE:** Before driving cylinder apart, position wobble plate toward front of compressor in area of the cross-over tube.

4. Carefully remove the rear half of the cylinder from the pistons and set the front cylinder half, with the piston, shaft and wobble plate, in fixture (J-9397).

5. Push up on the shaft and, one assembly at a time, remove pistons, rings, seats and balls placing

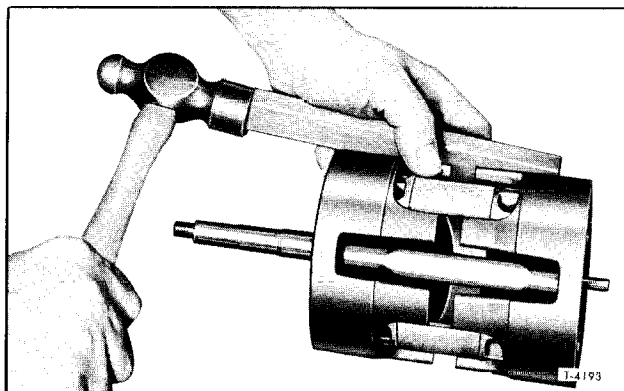

Figure 52—Separating Cylinder Halves

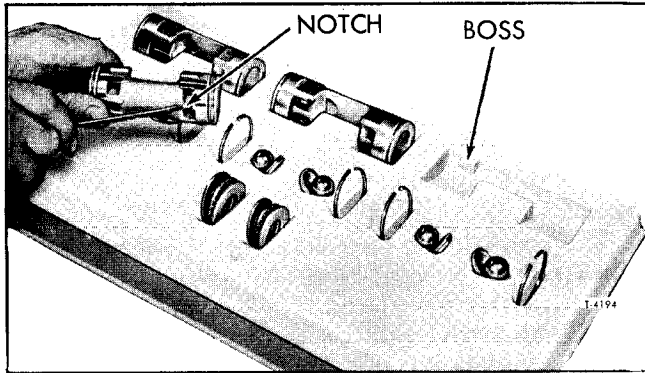

Figure 53—Notch Identifying Front End of Piston

all parts in tray (J-9402) in the compartment associated with the proper end of the piston. Discard all piston ball seats.

**NOTE:** The front of the piston may be identified by a notch in the casting web. See Figure 53. The piston compartments in tray (J-9402) have a boss at this notch location to indicate the front.

6. Remove and inspect all piston rings. Replace all broken or damaged rings. Damaged pistons must also be replaced.

7. Examine piston balls. Replace if they show burning or excessive wear.

8. Remove the rear combination of thrust races and bearing from the shaft and discard all three pieces.

9. Remove the shaft and wobble plate assembly from the front half of the cylinder.

10. Remove the front combination of thrust washers and bearing discard all three pieces.

11. Examine all surfaces of the wobble plate and, if satisfactory, reuse. If it shows signs of wear, replace the shaft and wobble plate as an assembly. Use care not to move wobble plate on the shaft. This is factory set.

12. Examine the front and rear cylinder halves and replace if cylinder bores are deeply scored or damaged.

13. Wash all parts to be reused in a suitable cleaner. Blow dry all parts.

14. If cylinder main bearings are to be replaced they may be removed and reinstalled at this time using tool (J-9432). Drive against the lettered end of the bearings and from the outside of the cylinder. Bearing must not be more than 1/8" below surface.

### Gauging Procedure

The gauging operations which follow have been worked out on a simple basis to establish and provide necessary running clearances. Two gauging procedures are necessary.

The first gauging operation is made to choose the proper size ball seats to provide, at each piston, a .0005" to .0010" total preload between the seats and the wobble plate at the tightest place through the 360 degree rotation of the wobble plate. The bronze ball seats are provided in .0005" variations including a basic ZERO seat.

The second gauging operation, performed at the rear shaft thrust bearing and race pack, is designed to obtain .0005" to .0015" preload between the hub surfaces of the wobble plate and the front and rear hubs of the cylinder. A total of 14 steel thrust races, including a basic ZERO race, are provided in increments of .0005" thickness to provide the required fit. Proper selection of thrust races and ball seats is of extreme importance.

1. Secure from service parts stock:

Four – ZERO thrust races

Three – ZERO ball seats

Two – New thrust bearings

2. Assemble a ZERO thrust race, a new needle thrust bearing and another ZERO thrust race, in that order, to front end of the shaft. (A dab of petroleum jelly will hold the bearing-race pack together and in place of shaft.) Lubricate front and rear faces of wobble plate with refrigeration oil.

3. With the front half of the cylinder assembly resting on tool (J-9397), insert the shaft, threaded end through the front main bearing until the thrust race assembly rests on the front cylinder hub.

4. Assemble a ZERO thrust race, a new needle bearing and a second ZERO thrust race in that order, to the rear of the shaft.

5. Apply a light smear of clean petroleum jelly to the ball pockets of each of the three pistons.

6. Place the balls in the piston pockets. The petroleum jelly will hold the balls in place.

7. Apply a light smear of petroleum jelly to the cavity of three new ZERO ball seats and place one seat over each front piston ball. There should now be a ball and seat in the front ball pocket of each piston and a ball only in the rear ball pocket.

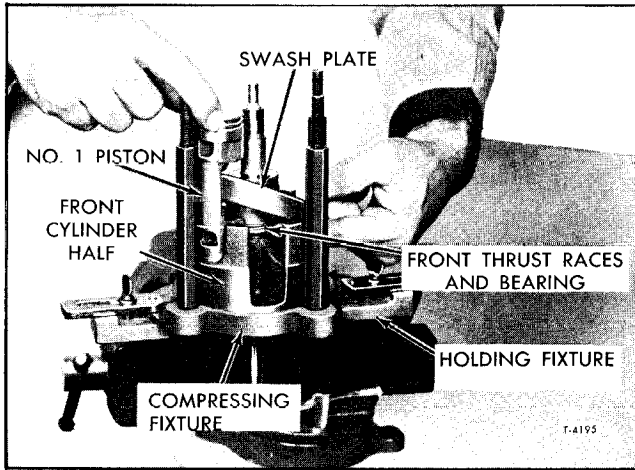

Figure 54—Installing Piston Front Ball and Seat and Rear Ball

**NOTE:** DO NOT assemble any of the piston rings at this time.

8. Rotate the shaft and wobble plate until the high point of the wobble plate is directly over the cylinder bore previously designated as No. 1. Lift up slightly on the shaft and wobble plate assembly, insert the front (notched) end of the No. 1 piston into the cylinder bore, and at the same time, place the front ball and seat and the rear ball only over the wobble plate (figure 54). Hold front thrust bearing pack tight against wobble plate hub while lifting shaft.

9. Repeat this operation with pistons Nos. 2 and 3.

10. Align the rear head casting with bores, suction passage, discharge cross-over holes, and dowel pins. Tap into place, using a plastic block and mallet (figure 55).

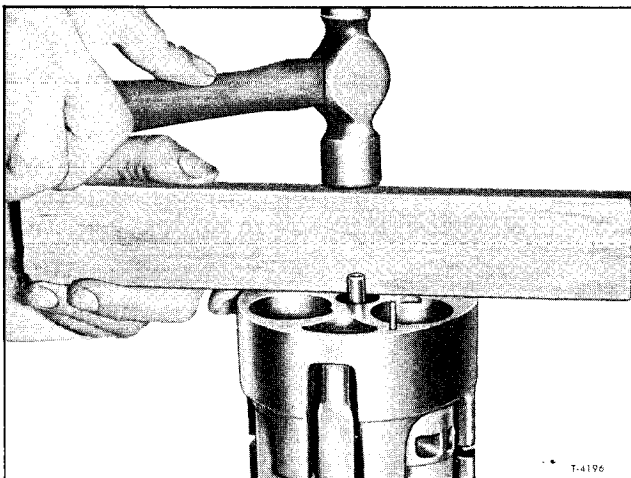

Figure 55—Assembling Cylinder Halves

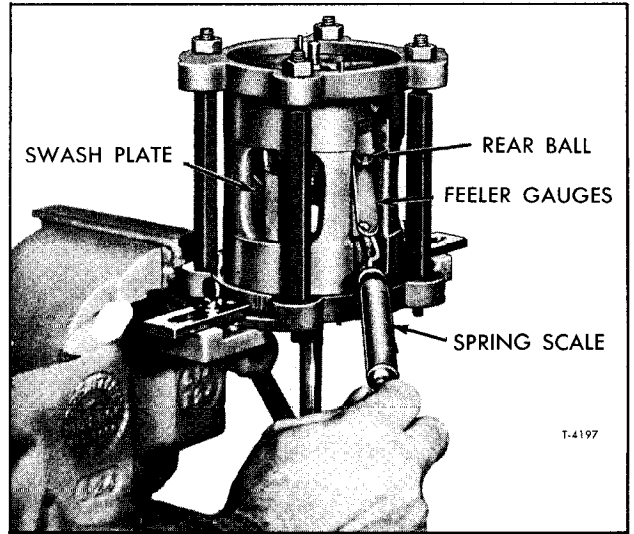

Figure 56—Checking Clearance Between Rear Ball and Wobble Plate

11. Place the cylinder assembly in the checking cage with the front of the compressor shaft pointing up, positioning the discharge tube opening between the cage bolts. This will provide access for the feeler gauge. Assemble the cage and tighten all nuts evenly to 14-16 foot-pounds torque.

12. Use a leaf-type feeler gauge and a suitable spring scale to check clearance between the REAR ball and the wobble plate (figure 56) of the No. 1 piston. Use a suitable combination of feeler gauge leaves until 4 to 8 ounces of force is required to pull gauge from between the ball and the plate.

**NOTE:** Use undamaged feeler gauges generously lubricated with refrigeration oil. Support the spring scale so that only the actual force required to pull the feeler gauge free is measured.

13. Rotate the shaft approximately 120 degrees and again check with a feeler gauge between the parts. Rotate the shaft another 120 degrees and make a third check. From this total of three feeler gauge checks, use the MINIMUM reading to select a numbered seat to correspond to the feeler gauge reading (i.e. - if minimum reading was .019", use a No. 19 seat. If reading was .0195", use a No. 19-1/2 seat). Place this seat in the parts tray in the compartment corresponding to the rear ball position of the No. 1 piston.

14. Repeat the operation described in Steps 12 and 13 for pistons No. 2 and No. 3.

15. The next gauging operation is to determine the space between the REAR thrust bearing and the upper (outer) rear thrust race. Use a suitable combination of feeler gauge leaves so that 4 to 8 ounces of force is required to pull gauge free (figure 57). Select

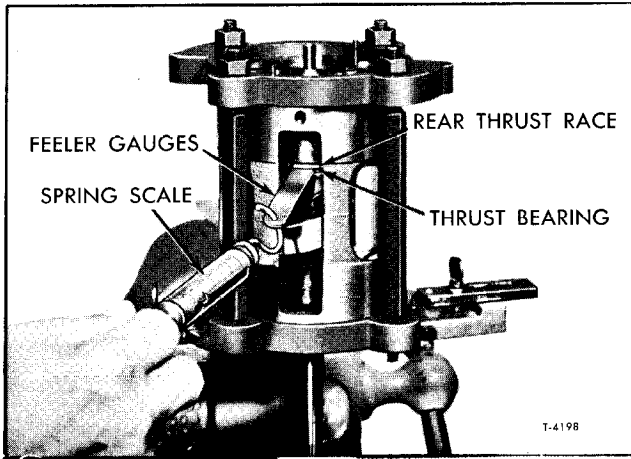

Figure 57—Checking Clearance Between Rear Thrust Bearing and Outer Thrust Race

a numbered thrust race to correspond to this feeler gauge reading and place this race in parts tray in the rear thrust race compartment.

16. Loosen the nuts and ring from the checking cage.

17. Drive the cylinder halves apart, using a fiber block and mallet.

18. Carefully remove the rear half of the cylinder and set the front half (including the pistons and shaft and wobble plate assembly) on fixture (J-9397).

19. Carefully remove one piston at a time from the wobble plate and the front half of the cylinder. Transfer each piston, ball and seat to its proper place in the parts tray along with the numbered rear seat chosen in Steps 12, 13 and 14.

**CAUTION:** *When the balls and seat are removed from the piston, be sure that they are placed in the proper parts tray pocket so as not to lose the relationship of the balls and seats to the proper end of the piston.*

20. Remove the rear outer (upper) ZERO thrust race from the compressor shaft and replace it with the numbered thrust race (determined in Step 15 previously) from the parts tray.

**NOTE:** This ZERO thrust race may be put aside for reuse in future gauging and/or rebuild operations.

21. The gauging operations are now complete.

### Assembly

After properly performing the gauging procedure and choosing the correct ball seats and thrust races

as outlined under "Gauging Procedure," the cylinder assembly may be reassembled. Be sure to install all new seals and O-rings. All are included in the compressor seal service kit.

### Assembly procedure is as follows:

1. Support the front half of the cylinder assembly on fixture (J-9397) and install the shaft and wobble plate, threaded end down, with its front bearing race pack (ZERO race, bearing and ZERO race) and its rear bearing race pack (ZERO race, bearing, numbered race) if this was not already done at the end of the "Gauging Procedure,"

2. Assemble a piston ring, scraper groove toward the center of the piston, to each end of the three pistons.

3. Apply a light smear of petroleum jelly to the numbered ball seats chosen in the gauging procedure and install all balls and seats (if removed in Step 19 of the gauging procedure) in their proper place in the piston.

4. Rotate the wobble plate so that the high point is above cylinder bore No. 1. Carefully assemble piston No. 1, complete with ball and ZERO seat on the front and ball and numbered seat on the rear, over the wobble plate. Hold front thrust pack tight against wobble plate hub while lifting hub. Compress and enter the piston ring into the front cylinder half.

5. Repeat this operation for pistons No. 2 and No. 3.

6. Assemble one end of a service discharge cross-over tube into the hole in the front cylinder half.

7. Rotate the shaft to position the pistons in a stair-step arrangement, then carefully place the rear cylinder half over the shaft and start the pistons into the cylinder bores.

8. Compress the piston ring on each piston to permit its entrance into the cylinder.

9. When all three pistons and rings are in their respective cylinders, align the end of the discharge cross-over tube with the hole in the rear half of the cylinder.

**NOTE:** Be sure the flattened portion of this tube faces the inside of the compressor to allow for wobble plate clearance.

10. When all parts are in proper alignment, tap with a fiber block and mallet to seat the rear half of the cylinder over the locating dowel pins. If necessary, clamp the cylinder in compressing fixture (J-

9397) to complete drawing the cylinder halves together.

11. Generously lubricate all moving parts with clean refrigeration oil and check for free rotation of the parts.

**NOTE:** It may be desirable to clamp the cylinder assembly in compressing fixture (J-9397) and check on the motor test stand for proper operation before proceeding further. If any improper operation is observed, the mechanism should be regauged to insure proper operation. Complete the assembly procedure when correct operation is obtained.

12. Replace the suction cross-over cover as shown in Figure 58. Compress the cover as shown to start it into the slot and then press it in until flush on both ends.

### Installation Into Shell

1. Support the cylinder on fixture (J-9521) with the threaded end of the shaft up.

2. Assemble the two dowel pins in the front cylinder if they are not already in place.

**NOTE:** A rod drilled 1/4" deep to the O.D. of the dowel pins will aid in installing.

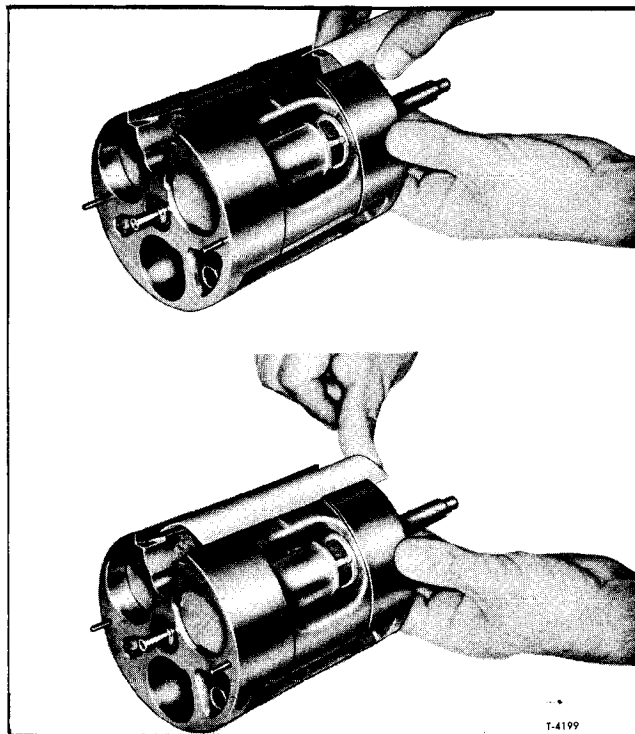

Figure 58—Installing Suction Crossover Cover

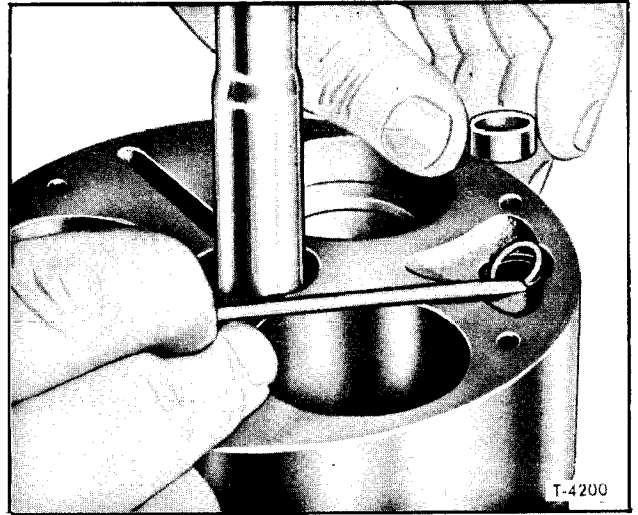

Figure 59—Installing Discharge Crossover Tube, Front O-Ring, and Spacer

3. Install the discharge cross-over tube front O-ring and spacer (figure 59).

4. Aligning the dowel pin holes, discharge cross-over and oil return slot, assemble the suction reed valve to the front end of the cylinder.

5. Assemble the front discharge valve plate, aligning the holes with the dowel pins and proper opening in the head.

**NOTE:** The front discharge plate has a larger diameter hole in the center than the rear discharge plate.

6. Check the teflon surface on the compressor front head casting webs and replace the entire casting if there is any evidence of damage. Discard the O-ring.

7. Coat the valve plate with clean refrigeration oil. Rotate the front head casting until it is properly positioned over the discharge reed retainers and dowel pins, then set it in place (being careful not to damage the teflon surfaces) and seat it over dowels with light mallet taps.

**NOTE:** Dowel pin and hole location can be marked with pencil to aid in locating the proper position.

8. Apply clean refrigeration oil to a new O-ring and O-ring groove at the lower edge of the front head casting and carefully assemble the O-ring in the groove.

9. Coat the inside machined surfaces of the compressor shell with refrigeration oil.

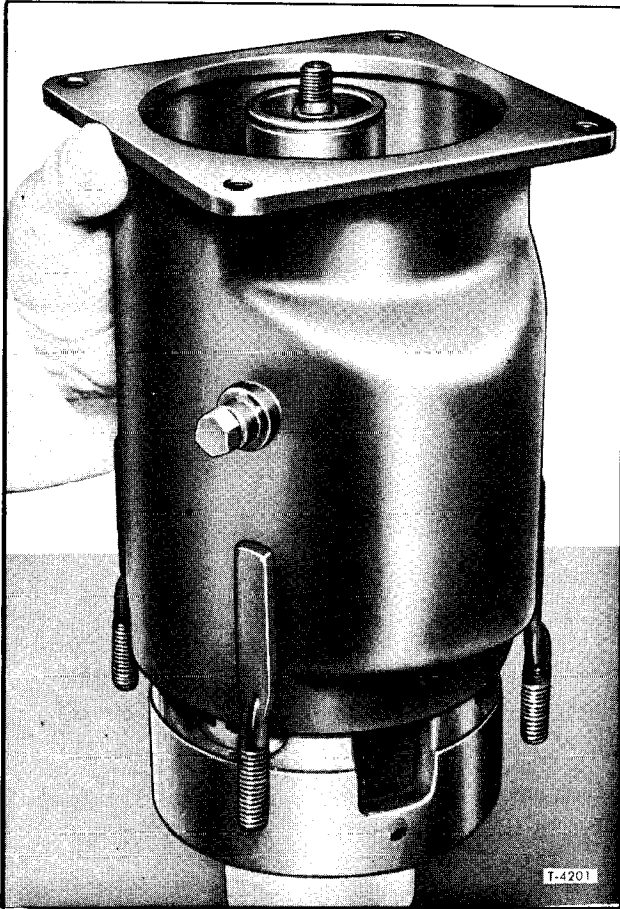

Figure 60—Installing Shell Over Internal Mechanism

10. Locate the oil intake tube in the rear discharge plate. Line up the oil sump with this hole location and slide the shell down over the mechanism while supporting the mechanism on support block (J-9521, figure 60).

11. Place compressor holding fixture (J-9396) in a vise and, carefully inverting the compressor shell with the mechanism inside, mount the front compressor flange on the support bracket.

12. Place a new O-ring in the oil intake tube hole applying clean refrigeration oil to the oil intake tube hole and the O-ring. Rotating the compressor mechanism to line up with the hole in the compressor oil sump baffle, install the pickup tube. Be sure that the O-ring and intake tube are properly seated.

13. Assemble the dowel pins into the rear cylinder.

14. Install the discharge cross-over tube rear O-ring and spacer.

15. Replace the rear suction reed valve, rear discharge valve plate, oil pump gears, rear head and head nuts as outlined previously under "Rear Head and Reed Assemblies – Installation."

## LEAK TESTING THE COMPRESSOR

Whenever service operations are performed on the compressor shaft seal assembly or on the interior mechanism, use the following procedure to leak test the reassembled compressor.

1. Install O-rings and cover plate (J-9527) over the suction and discharge ports of the compressor head.

2. Hook up a Refrigerant-12 container and

charging line using adapter (J-5420) to cover plate fitting over the suction port. Charge the compressor up to can pressure, then leak test compressor with a leak detector. Turn off the refrigerant container valve. Transfer gauge line and adapter to cover plate fitting over the discharge port and repeat the procedure outlined in Step 2.

3. Correct any leaks present.

## AIR CONDITIONING DIAGNOSIS

**NOTE:** Refer to Figures 61-63 for diagnosis details.

### REFRIGERANT SYSTEM

The following is a description of the type of symptom each refrigerant component will evidence if a defect occurs:

### COMPRESSOR

A compressor defect will appear in one of four ways: Noise, seizure, leakage, or low discharge pressure.

**NOTE:** Resonant compressor noises are not cause for alarm; however, irregular noise or rat-

tles may indicate broken parts or excessive clearances due to wear. To check seizure, deenergize the magnetic clutch and check to see if drive plate can be rotated. If rotation is impossible, compressor is seized (See "False Compressor Seizure"). To check for a leak, refer to leak testing earlier in this section. Low discharge pressure may be due to a faulty internal seal of the compressor, or a restriction in the compressor.

Low discharge pressure may also be due to an insufficient refrigerant charge or a restriction elsewhere in the system. These possibilities should be checked prior to servicing the compressor. If the compressor is inoperative, but is not seized, check to see if current is being supplied to the magnetic clutch coil terminals.

## CONDENSER

A condenser may be defective in two ways: it may leak, or it may be restricted. A condenser restriction will result in excessive compressor discharge pressure. If a partial restriction is present, sometimes ice or frost will form immediately after the restriction as the refrigerant expands after passing through the restriction. If air flow through the condenser or radiator is blocked, high discharge pressures will result. During normal condenser operation, the outlet pipe will be slightly cooler than the inlet pipe.

## RECEIVER-DEHYDRATOR

A defective receiver-dehydrator may be due to a restriction inside the body of the unit. A restriction at the inlet to the receiver-dehydrator will cause high head pressures. Outlet tube restrictions will be indicated by low head pressures and little or no cooling. An excessively cold receiver-dehydrator outlet may be indicative of a restriction.

## EXPANSION VALVE

A malfunction of the expansion valve will be caused by one of the following conditions: Valve stuck open, valve stuck closed, broken power element, a restricted screen or an improperly located or installed power element bulb. The first three conditions require valve replacement. The last two may be corrected by replacing the valve inlet screen and by properly installing the power element bulb.

Attachment of the expansion valve bulb to the evaporator outlet line is very critical. The bulb must be attached tightly to the line and must make good contact with the line along the entire length of the bulb. A loose bulb will result in high low side pressures and poor cooling.

Indications of expansion valve trouble are provided by Performance Test; consult Diagnostic Charts.

### VALVE STUCK OPEN

Noisy Compressor.

No Cooling – Freeze Up.

### VALVE STUCK CLOSED, BROKEN POWER ELEMENT OR PLUGGED SCREEN

Very Low Suction Pressure.

No Cooling.

### POORLY LOCATED POWER ELEMENT BULB

Normal Pressure.

Poor Cooling.

### Diagnosis for Defective Valve

The following procedure must be followed to determine if a malfunction is due to a defective expansion valve.

1. Check to determine if the system will meet the performance test as outlined previously. If the expansion valve is defective, the low pressure readings (evaporator pressure) will be above specifications.

2. The loss of system performance is not as evident when the compressor head pressure is below 200 psi. Therefore, it may be necessary to increase the system head pressure by partially blocking the condenser. Disconnect the blower lead wire and repeat the "performance check" to determine if the evaporator pressure can be obtained.

3. The system will also indicate a low refrigerant charge by bubbles occurring in the sight glass.

## EVAPORATOR

When the evaporator is defective, the trouble will show up as an inadequate supply of cool air. A partially plugged core due to dirt, a cracked case, or a leaking seal will generally be the cause.

### COMPRESSOR DIAGNOSIS

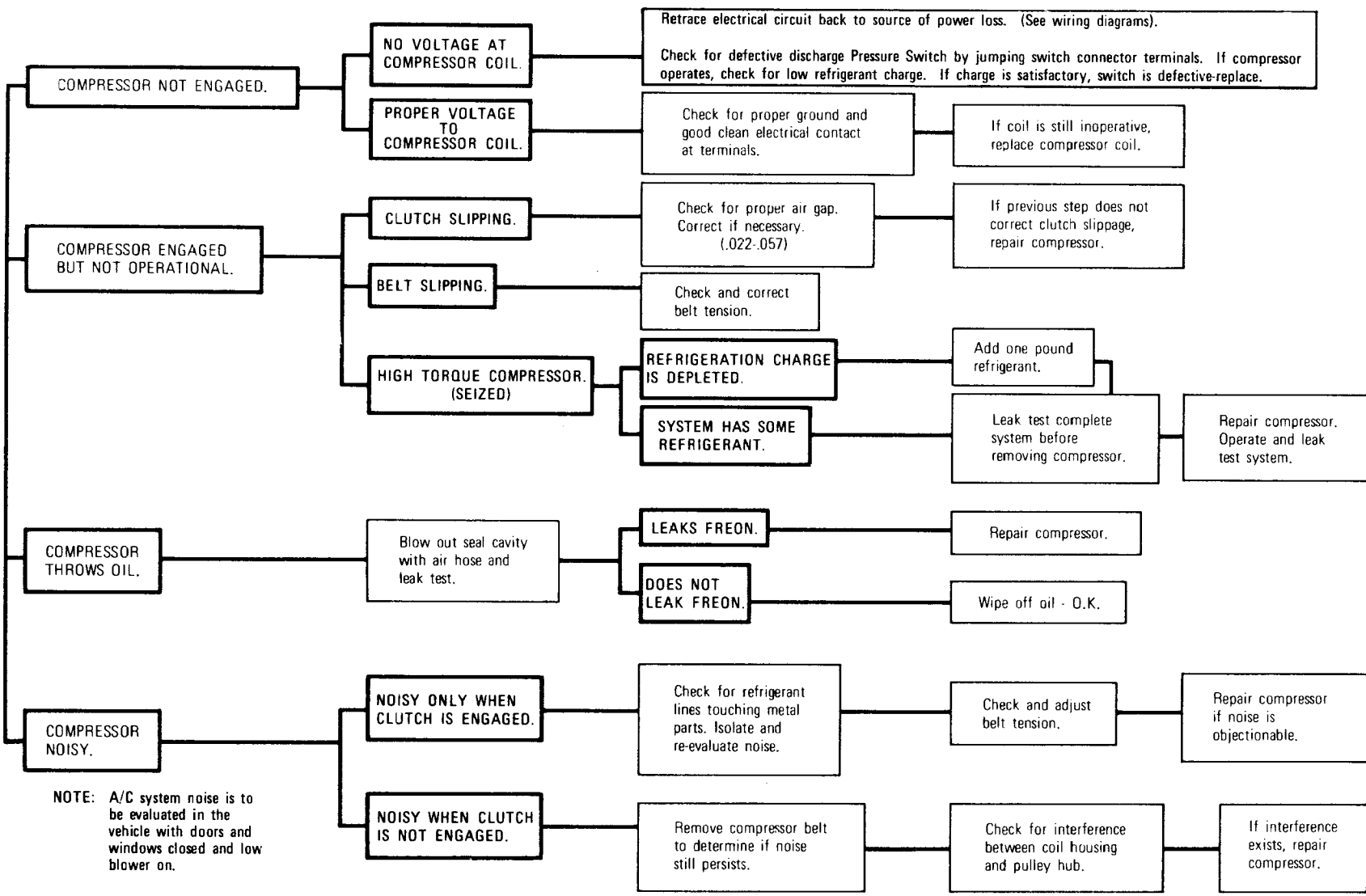

NOTE: A/C system noise is to be evaluated in the vehicle with doors and windows closed and low blower on.

Figure 61-Compressor Diagnosis



# INSUFFICIENT COOLING DIAGNOSIS CHART

The following procedures should be applied before performance testing an A/C System.

1. Check for proper belt installation and tension with J-23600.
2. Check for proper clutch coil terminal connector installation.
3. Check for clutch air Gap (.022 - .057).
4. Check for broken, burst, or cut hoses. Also check for loose fittings on all components.

5. Check for condenser air blockage due to foreign material.
6. Check for proper air ducting hose connections.
7. Check heater temperature door adjustment, adjust if incorrect.
8. Check evaporator sealing for air leak, repair if leaking.
9. Install pressure gages and thermometer and make performance test.

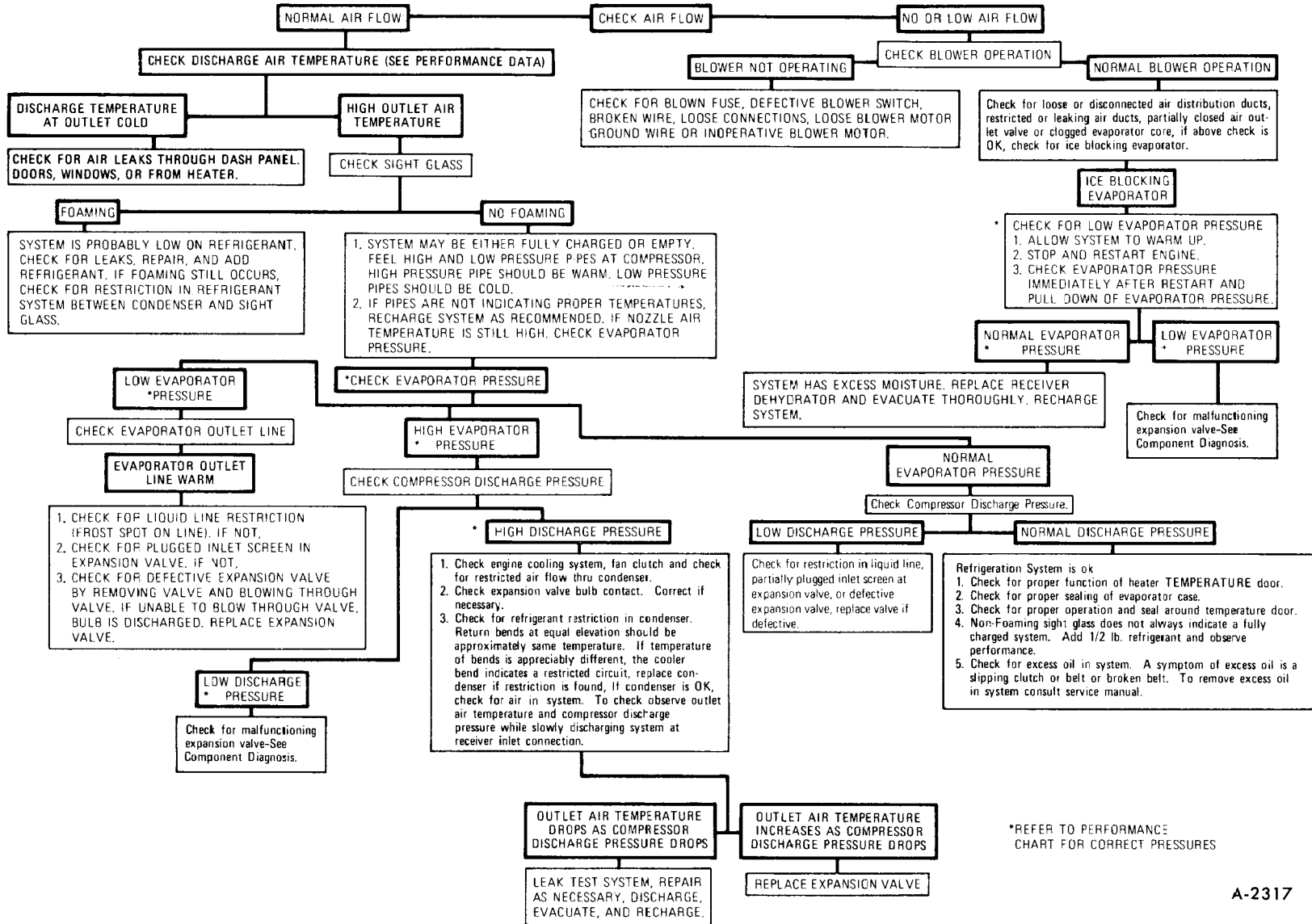

Figure 62-Insufficient Cooling Diagnosis

### ELECTRICAL SYSTEM DIAGNOSTIC CHART

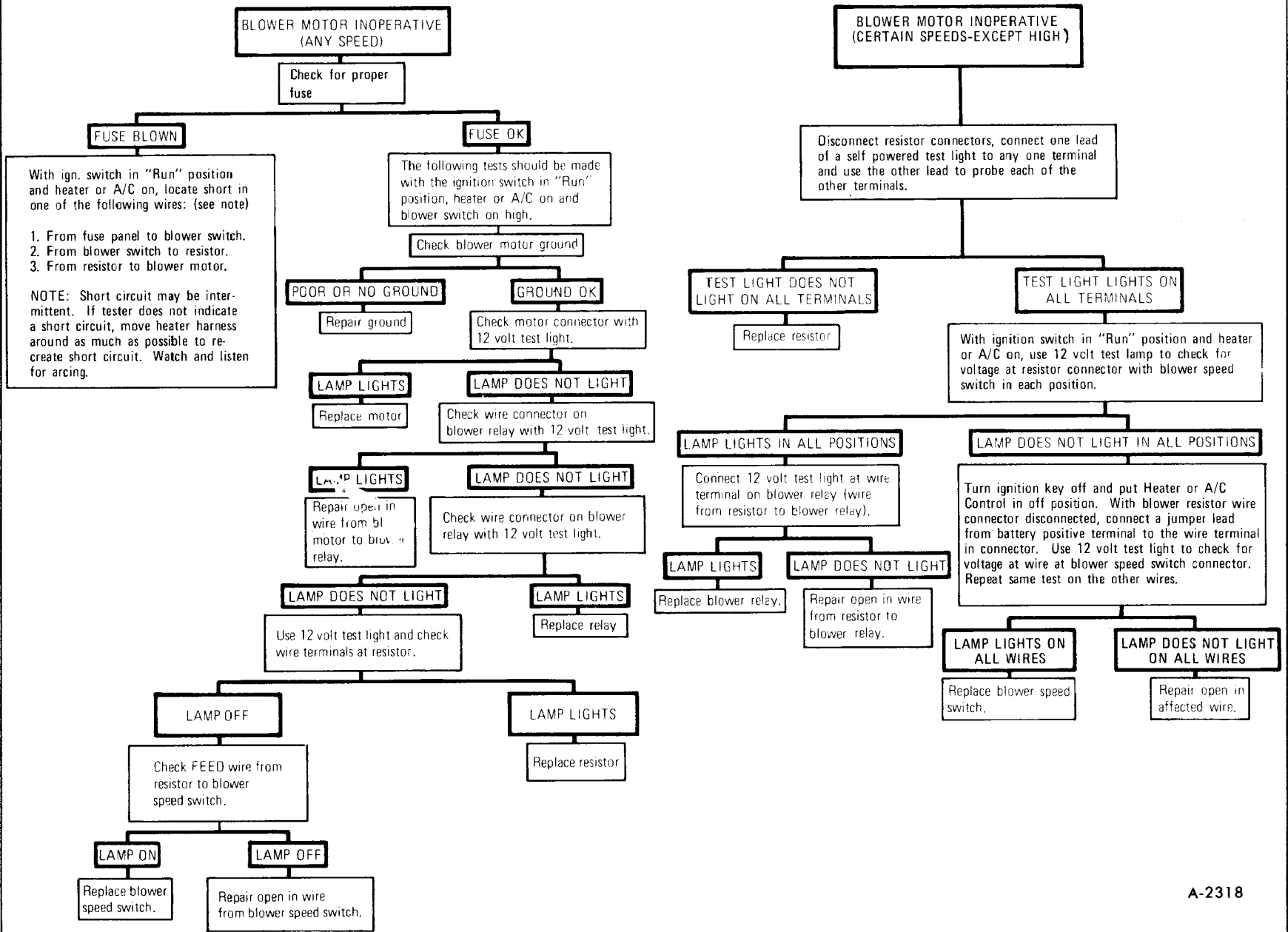

Figure 63-Electrical System Diagnosis

## REFRIGERANT LINE RESTRICTIONS

Restrictions in the refrigerant lines will be indicated as follows:

1. Suction Line – A restricted suction line will cause low suction pressure at the compressor, low discharge pressure and little or no cooling.

2. Discharge Line – A restriction in the discharge line generally will cause the pressure relief valve to open.

3. Liquid Line – A liquid line restriction will be evidenced by low discharge and suction pressure, and insufficient cooling.

## SIGHT GLASS DIAGNOSIS

At temperatures higher than 70 degrees F, the sight glass may indicate whether the refrigerant charge is sufficient. A shortage of liquid refrigerant is indicated after about five minutes of compressor operation by the appearance of slow-moving bubbles (vapor) or a broken column of refrigerant under the glass. Continuous bubbles may appear in a properly charged system on a cool day. This is a normal situation. If the sight glass is generally clear and performance is satisfactory, occasional bubbles do not indicate refrigerant shortage.

If the sight glass consistently shows foaming or a broken liquid column, it should be observed after partially blocking the air to the condenser. If under this condition the sight glass clears and the performance is otherwise satisfactory, the charge shall be considered adequate.

In all instances where the indications of refrigerant shortage continues, additional refrigerant should be added in 1/4 lb. increments until the sight glass is clear. An additional charge of 1/2 lb. should be added as a reserve after the glass clears. In no case should the system be overcharged.

## ELECTRICAL SYSTEM

For electrical connections and routings, refer to the wiring diagram at the end of the manual. Also see Figure 63.

## VACUUM SYSTEM DIAGNOSIS

Start the engine and allow it to idle – move the selector lever to each position and refer to the vacuum diagrams and operational charts for proper airflow, air door functioning and vacuum circuits. If airflow is not out of the proper outlets at each selector lever position, then proceed as follows:

1. Check for good hose connection – at the vacuum actuators, control head valve, reservoir, tees, etc.

2. Check the vacuum source circuit as follows:

Install vacuum tee and gauge (with restrictor) at the vacuum tank outlet (see Vacuum Diagram). Idle the engine and read the vacuum (a normal vacuum is equivalent to manifold vacuum) at all selector lever positions.

a. Vacuum Less Than Normal At All Positions –

Remove the tee and connect the vacuum gauge line directly to the tank – read the vacuum. If still low, then the problem lies in the feed circuit, the feed circuit to the tank or in the tank itself. If vacuum is now normal, then the problem lies downstream.

b. Vacuum Less Than Normal at Some Positions –

If vacuum was low at one or several of the selector lever positions, a leak is indicated in these circuits.

c. Vacuum Normal at All Positions –

If vacuum was normal and even at all positions, then the malfunction is probably caused by improperly connected or plugged lines or a defective vacuum valve or valves.

3. Specific Vacuum Circuit Check

Place the selector lever in the malfunctioning position and check for vacuum at the pertinent vacuum actuators. If vacuum exists at the actuator but the door does not move, then the actuator is defective or the door is mechanically bound. If low or no vacuum exists at the actuator, then the next step is to determine whether the cause is the vacuum harness or the vacuum valve. Check the vacuum harness first.

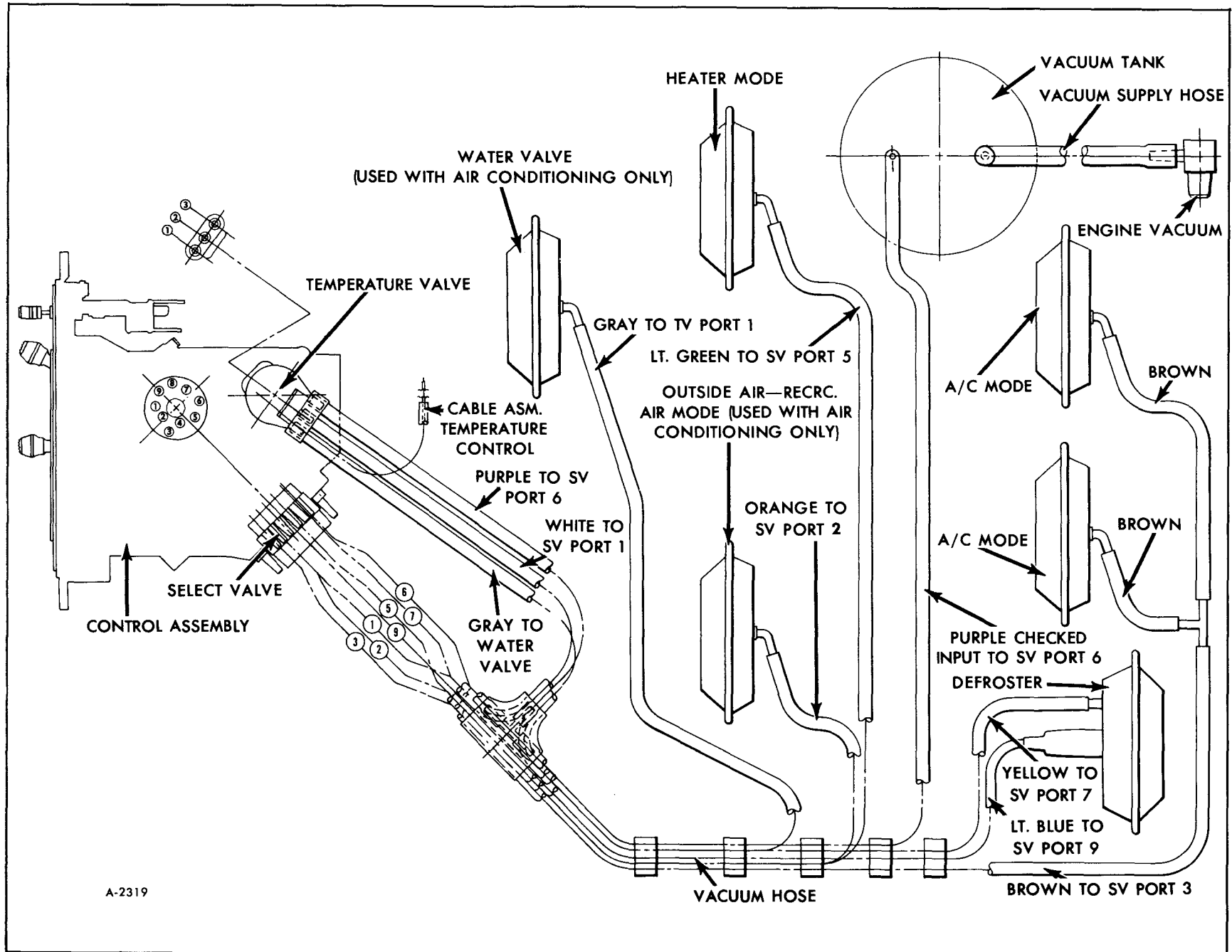

A-2319

Figure 64-Vacuum Control Diagram

# VACUUM CONTROL CHARTS (USE WITH FIGURE 64)

## TEMPERATURE VALVE OPERATING CHART

3	VACUUM INPUT	VAC	VAC	SEAL	PURPLE
2	R. A. OVERRIDE	VAC	VENT	VENT	WHITE
1	HOT WATER VALVE	VAC	VAC	VENT	GRAY
PORT NO.	CONNECTION	RECIRC.	COLD	HOT	COLOR

## SELECT VALVE OPERATING CHART

9	Defrost. Outlet	Vent	Vent	Vent	Vent	Vent	Vac	Lt. Blue
8	No. Connection							
7	Defrost. Bleed	Vent	Vent	Vent	Vac	Vent	Vac	Yellow
6	Checked Input	Seal	Vac	Vac	Vac	Vac	Vac	Purple
5	Htr. Outlet	Vent	Vent	Vac	Vac	Vac	Vac	Lt. Green
4	No Connection							
3	A/C Outlet	Vent	Vac	Vac	Vent	Vac	Vent	Brown
2	O.A. - R.A.	Vent	Conn. 1	Vent	Vent	Vent	Vent	Orange
1	R. A. Over ride	Seal	Conn. 2	Seal	Seal	Seal	Seal	White
Port No.	Connection	Off	A/C	Vent	Heater		Def.	Color

## SPECIAL TOOLS

J-5403	Snap Ring Pliers	J-9432	Needle Bearing Installer
J-5420	Gauge Adapter	J-9459	Gauge Adapter
J-6084	Leak Detector	J-9480	Hub and Drive Plate Assembly Installer
J-6435	Snap Ring Pliers	J-9481	Pulley and Bearing Installer
J-8092	Handle	J-9521	Support Block
J-8433	Pulley Puller	J-9527	Pressure Test Connector
J-9392	Seal Remover	J-9553	O-Ring Remover
J-9395	Puller Pilot	J-21303	Shaft Seal Protector
J-9396	Compressor Holding Fixture	J-21508	Seal Seat O-Ring Installer
J-9397	Compressing Fixture	J-23128	Seal Seat Remover
J-9398	Pulley Bearing Remover	J-23600	Belt Tension Gauge
J-9399	9/16" Thin Wall Socket	J-24095	Oil Inducer
J-9402	Parts Tray	J-24410	Charging Station
J-9403	Spanner Wrench		

## HEATING SYSTEM (WITHOUT AIR CONDITIONING) CONTROL OPERATION

The heating system controls (figure 1) are located on the instrument panel to the right of the steering column. There are three separate controls:

“FAN” lever to control speed of blower operation; “RECIRC,” “COLD,” “HOT” lever to control temperature of air; “OFF,” “VENT,” “HEATER,” “DEF” lever to control direction of air flow. The “FAN” lever works vertically and the other two levers work horizontally. The three levers may be placed in any combined position to deliver the climate conditions most desirable at any given time.

“FAN” – The fan switch has four positions; “OFF” and three blower speeds ranging to “HI” and two unmarked positions between “OFF” and “HI.” The fan will not operate unless the top lever has been moved from the “OFF” position, and in order to operate the fan in the “HI” position the engine must be running.

“OFF,” “VENT,” “HEATER,” “DEF” – With the lever in the “OFF” position the system is off. With the lever in the “VENT” position 100% outside air enters the driver’s compartment. The air enters through the dash mounted outlets and through the heater outlets. Temperature of incoming air may be controlled by moving the “RECIRC,” “COLD,” “HOT” (temperature) lever to desired position. Any one of the three blower speeds may be selected.

With the lever in the “HEATER” position, air will flow through the heater floor distributor outlet (with slight flow of air to the defroster outlet). For maximum heat, move temperature lever to “HOT”

position and “FAN” switch lever to “HI” position. Heating system output can be varied by moving temperature lever and “FAN” lever to different positions.

With the lever in the “DEF” position, the system operates the same as in the “HEATER” position except most of the air flow will be through the defroster outlets at the windshield.

“RECIRC,” “COLD,” “HOT” – This lever, used in conjunction with the system selector lever (“OFF,” “VENT,” “HEATER,” “DEF”) and the “FAN” switch lever, will control the temperature of the output air being distributed.

Clear windshield, rear window, outside mirror, and all side windows of ice and snow before driving vehicle.

Operate blower on “HI” for a few seconds before moving the vehicle, to clear the air intakes of snow.

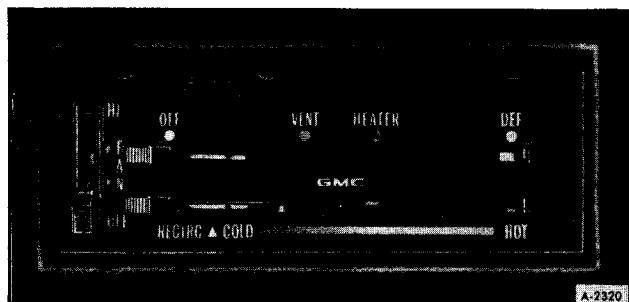

Figure 1—Heating System Controls

## COMPONENT REPLACEMENT

### CONTROL ASSEMBLY

Procedures for the replacement of the heating system control assembly is the same as models equipped with air conditioning. See “Control Assembly Replacement” under air conditioning portion of this section.

### BLOWER COMPONENTS

Replacement procedures for the blower motor, blower relay, and blower resistor are the same as

described in the air conditioning portion of this section.

### HEATER CORE

Replacement procedures for the heater core is the same as for models equipped with air conditioning. See “Evaporator and Heater Core Replacement” in air conditioning portion of this section.

### VACUUM CONTROLS

Before replacing any vacuum control compo-

nents check system for proper operation. Controls are the same as air conditioned models, except for the deletion of the water valve and "Outside Air-Recirc.

Air mode". Lines to these components are simply plugged. For details see vacuum control charts and Figure 64 in air conditioning portion of this section.

# SECTION 2

## FRAME

Contents of this section are listed below:

SUBJECT	PAGE NO.
General.....	2-1
Frame Alignment.....	2-1
Frame Material .....	2-2
Replacing Frame Extension .....	2-2
Body Mounting .....	2-5

### GENERAL

The model 230 and model 260 Motor Home chassis use a channel type frame with a front frame extension, bolted cross members and a rear frame extension. An exploded view of the frame components is shown in Figure 1. A model 260 frame is shown; the model 230 frame differs in the length of the side rail and one less crossmember.

When supporting the Motor Home for servicing on a floorjack or jackstands the vehicle should not be supported at the extreme ends of the frame or at the center of a frame rail. Refer to Section 0 for hoisting and jacking instructions.

In the event the vehicle is damaged in a collision, carefully check for proper frame alignment in addition to steering geometry and wheel alignment.

### FRAME ALIGNMENT

The most convenient way to check frame alignment is to select various corresponding points of measurement on the outside of each side rail and then, by use of a plumb bob, transfer these points to a layout on a level floor. (Note: Flange width may vary and should not be used as a reference point.)

Since the frame is basically made of three different sections, the procedure for checking the frame is as follows:

### CHECKING ALIGNMENT

The diagram shown in Figure 2 can be used to check the alignment of a Motor Home frame that has been distorted.

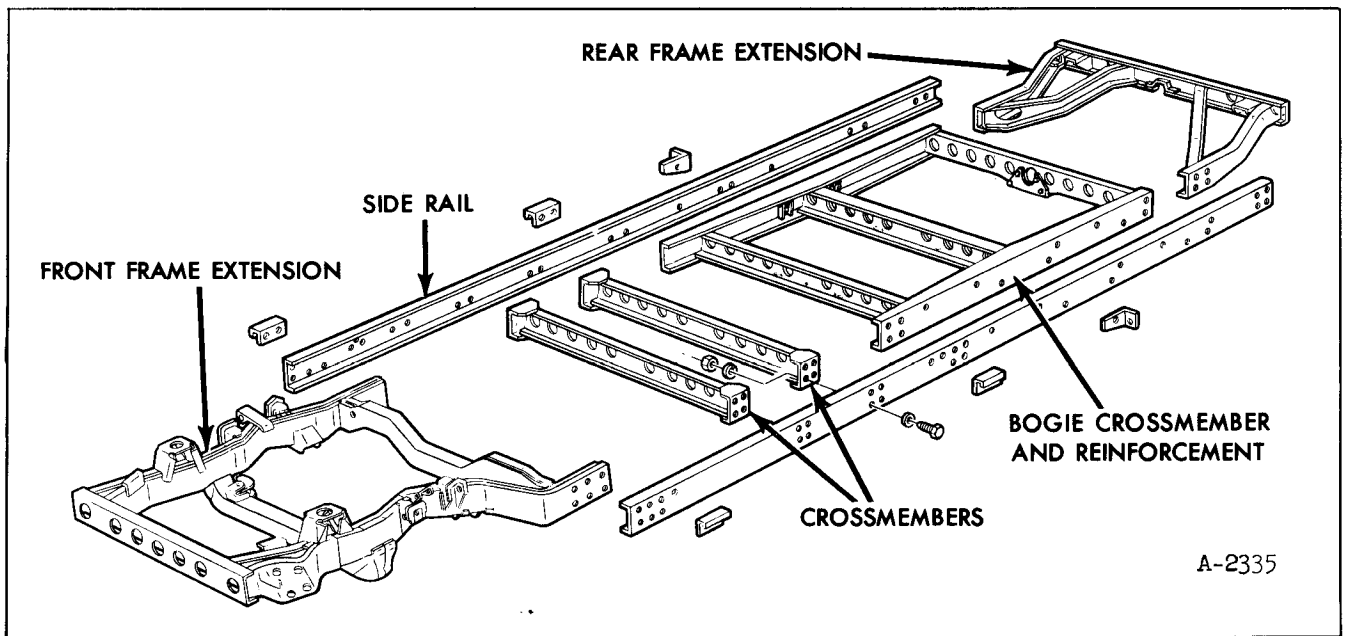

Figure 1—Frame Components



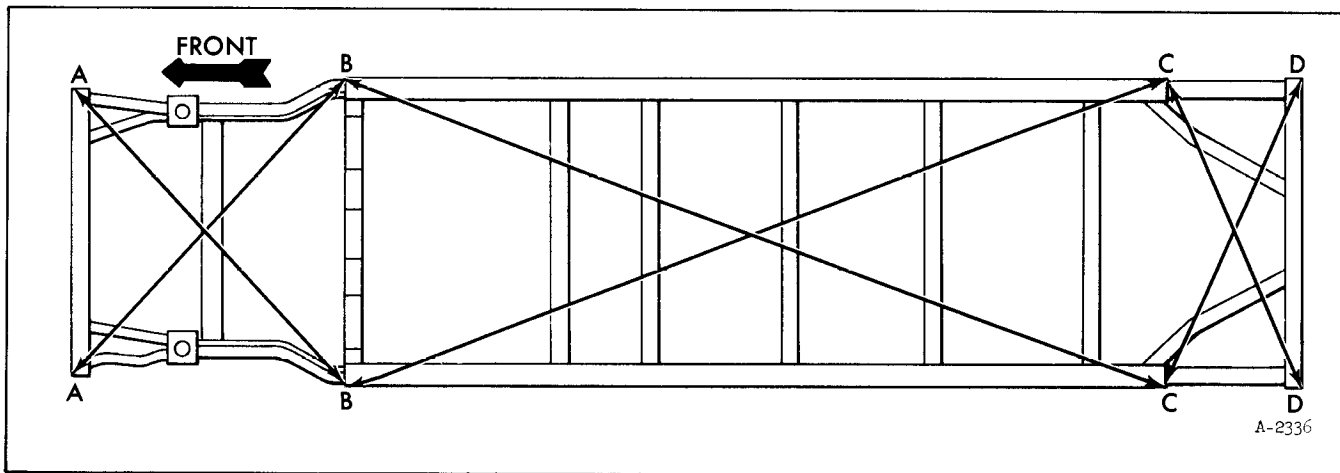

Figure 2-Frame Alignment

Corresponding measurements must be equal within 1/4".

1. Measure A-B. If not equal, front end of frame is misaligned.
2. Measure B-C. If not equal, center portion of frame is misaligned.
3. Measure C-D. If not equal, then rear suspension crossmember is misaligned.

**FRAME REPAIR**

In case of collision, frame members can often be satisfactorily straightened to the required limits. However, the front suspension crossmember is made to unusually close limits necessary for proper front wheel alignment; therefore, straightening of this unit may not be successful.

It is possible that the ordinary straightening methods will suffice for minor damage to the front suspension crossmember; however, in case of serious damage or fracture, the entire front suspension crossmember or front frame extension must be replaced. Before the member is replaced, it is essential that the frame alignment be checked, and corrected if necessary.

**FRAME MATERIAL**

The frame material is 950-1023-1080 steel. The frame may be welded if necessary using electrodes noted in table 1.

**NOTE:** It is NOT recommended that the frame be welded to repair. Replacement of major components is recommended if there is substantial frame damage – such as from collisions, etc.

**ELECTRODE USAGE WITH FRAME MATERIAL**

Material .....	1023-950 steel
Type or Electrode .....	E7018

**REPLACING FRAME EXTENSION**

The purpose of this section is to enable a technician to change a front or rear frame extension due to

extensive damage from a collision, etc. It is not recommended that this procedure be used until it is determined that the frame is definitely out of alignment and is unable to be fixed by the usual frame straightening operations.

## FRONT FRAME EXTENSION REMOVAL

The front frame extension should only be replaced if absolutely necessary due to the complexity and amount of labor involved.

**NOTE:** To drain, disconnect, or remove certain components it may be necessary to refer to additional sections in this maintenance manual (such as, draining gas tanks; Refer to Section 8 "Fuel Tank and Exhaust").

### Drain

1. Drain power steering fluid.
2. Drain brake fluid.
3. Release freon from A/C system.
4. Drain gas tanks.
5. Drain engine cooling system.

### Disconnect

1. Fuel Filler hose at front elbow.
2. Hose from tube going to charcoal canister.
3. If two canister are used, disconnect hoses from the one mounted on the stepper.
4. Rear brake line from combination valve.
5. Heater hoses and pre-heater at engine.
6. Vacuum lines at cruise control.
7. Power brake vacuum line.
8. Hose to thermasan switch.
9. Speedometer cable at cruise control (at transmission without cruise control).
10. Accelerator cable at carburetor.
11. Transmission shift cable at transmission.
12. Oil filler tube at front end.
13. Vacuum line at vacuum tank mounted on the side of the heater.
14. Brake lines at master cylinder.
15. Hydraulic lines to windshield wiper motor.

16. Air lines.

### Remove

1. Remove Engine, Transmission, and Final Drive Assembly.
2. Remove mufflers and Y-pipe.
3. Remove torsion bars and rear torsion bar support.
4. Take steering gear off of frame and remove front bumper assembly.
5. Remove batteries and battery box with air tank.
6. Remove parking brake cable from front frame section.
7. Remove thermasan hose from unit on exhaust pipe (if used).
8. Remove front body mount bolts.
9. Remove frame section bolts.
10. Air conditioning compressor and hoses (cap all A/C hoses).
11. Front wheels.
12. Front fender wells.
13. Grille.
14. Lower fiberglass section below grille.
15. Radiator.
16. After the bolts holding the front frame extension are removed it will be possible to pull it forward and down clearing the body. A high capacity floor jack should be used to move the front frame extension forward and down.

## FRONT FRAME EXTENSION INSTALLATION

Installation of the front frame extension is accomplished by reversing the removal procedures.

## REAR FRAME EXTENSION REMOVAL

1. Remove rear bumper by removing both

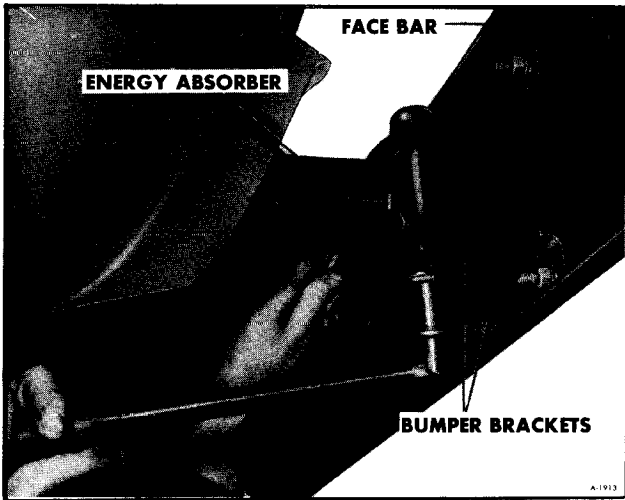

Figure 3-Removing Rear Bumper

bumper bracket thru bolts as shown in Figure 3. Then remove face bar assembly.

2. Remove the 4 bolts and nuts securing energy absorbers to the frame.

3. Remove spare tire carrier from rear crossmember by removing 8 bolts and nuts.

4. Using a small hydraulic or screw jack and a 3 foot wood 2x4, place jack in the middle of floor section using the 2x4 to support the floor weight, lengthwise.

5. Remove the bolt in each rear mounting pad. Location of mounts are shown in Figure 4.

**NOTE:** To reach bolt head inside rear of Motor Home some interior components may have to be removed.

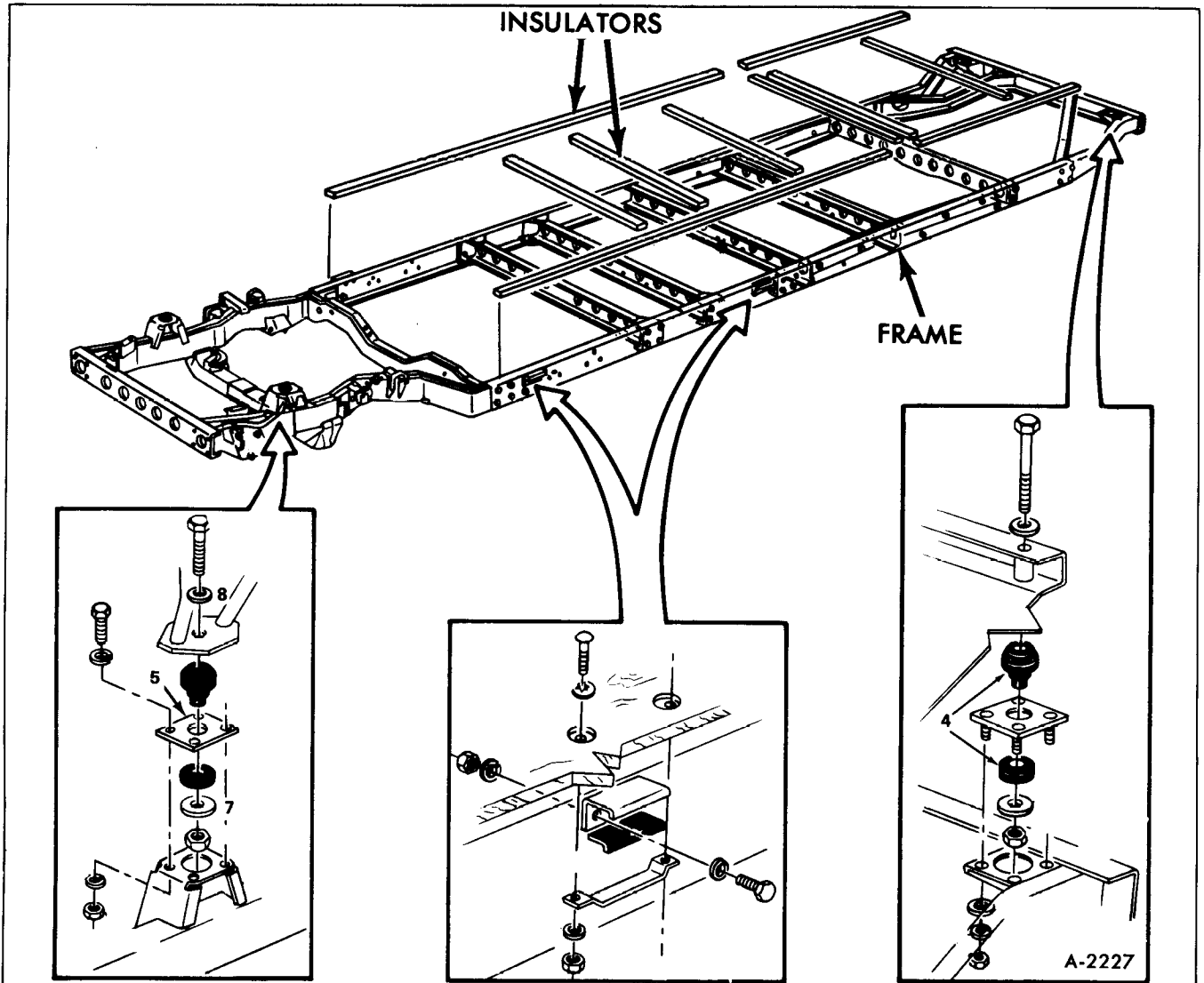

Figure 4-Body Mountings

6. Remove tailpipe from rear section by loosening clamp at slip joint.

7. Drain water from water supply tank.

8. Remove holding tank dump pipe from retaining clamp on rear crossmember.

9. Remove motor generator assembly (if so equipped).

10. Remove 8 nuts and bolts securing rear frame extension to side rails.

11. Slide out rear frame extension.

## REAR FRAME EXTENSION INSTALLATION

Installation of the rear frame extension is accomplished by reversing the removal procedures.

## BODY MOUNTING

Should it become necessary to replace any body mounting components, refer to figure 4. Front and rear body mount nut torque is 50 - 60 foot-pounds.

If any of the insulators between the frame and body must be replaced, be sure the old insulator is entirely removed. Then using a waterproof adhesive attach new insulator to frame in locations shown in Figure 4.



# SECTION 3 FRONT SUSPENSION AND FINAL DRIVE

## SECTION 3A

### FRONT SUSPENSION

**CAUTION:** *Front suspension fasteners are important attaching parts in that they could affect the performance of vital components and systems, and/or could result in major repair expense. It must be replaced with one of the same part number or with an equivalent part if replacement becomes necessary. Do not use a replacement part of lesser quality or substitute design. Torque values must be used as specified during reassembly to assure proper retention of this part.*

Contents of this section are listed below:

SUBJECT	PAGE NO.
Trouble Diagnosis .....	3A-2
Theory and Operation .....	3A-5
General Description .....	3A-8
Disc Hub Assembly .....	3A-8
Hub Bearing .....	3A-8
Disc .....	3A-9
Knuckle Seal R.H. ....	3A-11
Knuckle Seal L.H. ....	3A-12
Knuckle .....	3A-12
Upper Control Arm .....	3A-13
Upper Control Arm Bushing .....	3A-14
Lower Control Arm .....	3A-14
Lower Control Arm Bushing .....	3A-16
Ball Joint .....	3A-17
Ball Joint Checks .....	3A-17
Lower Control Arm Ball Joint .....	3A-18
Upper Control Arm Ball Joint .....	3A-18
Stabilizer Bar .....	3A-19
Shock Absorber .....	3A-19
Torsion Bar .....	3A-19
Crossmember Support .....	3A-19
Ride Height .....	3A-20
Front End Alignment .....	3A-21
Alignment Adjustment .....	3A-21
Torque Specifications .....	3A-22
Special Tools .....	3A-23

Problem	Possible Cause	Correction
Noise in Front End	<ol style="list-style-type: none"> <li>1. Ball joints and steering linkage lubrication.</li> <li>2. Shock absorber loose or bushings worn.</li> <li>3. Worn control arm bushings.</li> <li>4. Worn tie rod ends.</li> <li>5. Loose stabilizer bar.</li> <li>6. Loose wheel nuts.</li> <li>7. Loose suspension bolts.</li> </ol>	<ol style="list-style-type: none"> <li>1. Lubricate at recommended intervals.</li> <li>2. Tighten bolts and/or replace bushings.</li> <li>3. Replace bushings.</li> <li>4. Replace tie rod ends.</li> <li>5. Tighten all stabilizer bar attachments.</li> <li>6. Tighten the wheel nuts to proper torque.</li> <li>7. Torque to specifications or replace.</li> </ol>
Tire Thump	<ol style="list-style-type: none"> <li>1. Tire and wheel out of balance.</li> <li>2. Tire and wheel out of round.</li> <li>3. Blister or bump on tire.</li> <li>4. Improper shock absorber action.</li> </ol>	<ol style="list-style-type: none"> <li>1. Balance wheels.</li> <li>2. Replace tire.</li> <li>3. Replace tire.</li> <li>4. Replace shock absorber.</li> </ol>
Excessive or Uneven Tire Wear	<ol style="list-style-type: none"> <li>1. Underinflated or overinflated tires.</li> <li>2. Improper toe-in.</li> <li>3. Wheels out of balance.</li> <li>4. Hard Driving.</li> <li>5. Over loaded vehicle.</li> </ol>	<ol style="list-style-type: none"> <li>1. Inflate tire to proper recommended pressure.</li> <li>2. Adjust toe-in.</li> <li>3. Balance wheels.</li> <li>4. Instruct driver.</li> <li>5. Instruct driver.</li> </ol>
Scuffed Tires	<ol style="list-style-type: none"> <li>1. Toe-in incorrect.</li> <li>2. Excessive speed on turns.</li> <li>3. Tires improperly inflated</li> <li>4. Suspension arm bent or twisted.</li> </ol>	<ol style="list-style-type: none"> <li>1. Adjust toe-in to specifications.</li> <li>2. Advise driver.</li> <li>3. Inflate tires to proper recommended pressure.</li> <li>4. Replace arm.</li> </ol>
Cupped Tires	<ol style="list-style-type: none"> <li>1. Front shock absorbers defective.</li> <li>2. Worn ball joints.</li> <li>3. Wheel and tire out of balance.</li> <li>4. Excessive tire or wheel runout.</li> </ol>	<ol style="list-style-type: none"> <li>1. Replace shock absorbers.</li> <li>2. Replace ball joints.</li> <li>3. Balance wheel and tire.</li> <li>4. Compensate for runout.</li> </ol>

Problem	Possible Cause	Correction
Shock Absorber-Weak.	<ol style="list-style-type: none"> <li>1. Low or uneven tire pressure.</li> <li>2. Excessive or incorrect vehicle loading.</li> <li>3. Worn out shock absorber (Front).</li>   <li>4. Worn out shock absorber (Rear).</li> </ol>	<ol style="list-style-type: none"> <li>1. Inflate tires to the proper recommended pressure.</li> <li>2. Instruct driver.</li>   <li>3. Perform on vehicle test. Push down and lift up at end of bumper nearest front shock in question. right and left shocks must be comparable in rebound resistance to compression ration (usually 2 to 1). If in doubt compare with vehicle having acceptable ride quality.</li> <li>4. Disconnect the lower shock mountings. Stroke shocks at various rates of speed through maximum travel in both directions. Compare side to side for rebound and compression resistance. Rebound resistance is normally stronger than compression (approximately 2 to 1). It is mandatory that right and left shocks feel comparable. If in doubt about condition, compare wth a known good shock.</li> </ol>
Shock Absorber-Noisy.	<ol style="list-style-type: none"> <li>1. Loose mounting.</li> <li>2. Faulty shock absorber</li> </ol>	<ol style="list-style-type: none"> <li>1. Check all shock mounting torques (bolt and/or nut).</li> <li>2. Observe hoisting instructions and instructions for removal of front shock absorbers. Clamp shock upside down. Clamp vise on top mount with shock vertical in vise (do not clamp on reservoir tube). Rear shocks may be tested on the vehicle by disconnecting the lower mount. Completely extend to full rebound then exert an extra pull. If a "GIVE" is felt a loose piston is indicated and the shock should be replaced. A hissing noise (orifice swish) is normal, however, replace shock absorber for any of the following:             <ol style="list-style-type: none"> <li>a. A skip or lag at reversal near mid-stroke.</li> <li>b. A seize (except at either extreme end of travel).</li> <li>c. A noise such as a grunt or squeal after completing one full stroke in both directions.</li> <li>d. A clicking noise at fast reversal.</li> </ol> </li> </ol>

Problem	Possible Cause	Correction
Shock Absorber—Leaks.	1. Faulty shock absorber.	<p>1. A slight trace of shock fluid is NOT cause for replacement as the seal permits some seepage for lubrication of the piston rod. The shock contains a fluid reserve to compensate for seepage.</p> <p>A shock that is truly leaking is easily detected as there will be evidence of shock fluid around the seal cover and on down the reservoir tube and should be replaced.</p>

## THEORY AND OPERATION

### FRONT-END GEOMETRY

The term "FRONT-END GEOMETRY" refers to the angular relationship between the front wheels, the front suspension attaching parts and the ground. The angle of the knuckle (now called steering axis inclination) away from the vertical, the pointing in or "TOE-IN" of the front wheels, the tilt of the front wheels from vertical (when viewed from the front of the vehicle) and the tilt of the suspension members from vertical (when viewed from the side of the vehicle) - all these are involved in front-end geometry. These items have an effect on the steering ease, steering stability and riding qualities of the Motor Home

and has a direct effect on tire wear. The various factors that enter into front-end geometry are covered here each one under its own heading.

### CAMBER (FIGURE 1)

Camber is the tilting of the front wheels from the vertical. When the wheels tilt outward at the top, the camber is said to be positive (+). When the wheels tilt inward at the top, the camber is said to be negative (-). The amount of tilt is measured in degrees from the vertical and this measurement is called the camber angle.

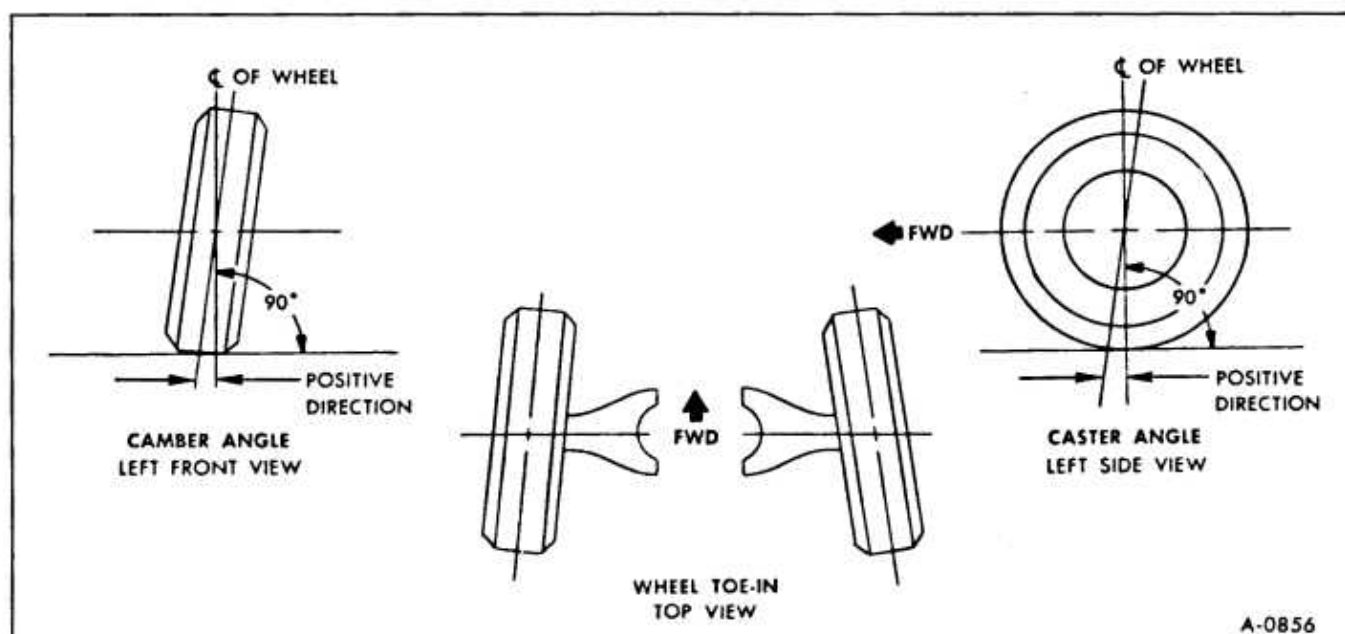

Figure 1—Caster, Camber and Toe-In



## CASTER (FIGURE 1)

Caster is the tilting of the front steering axis either forward or backward from the vertical. A backward tilt is said to be positive (+) and a forward tilt is said to be negative (-). You cannot see caster angle without special instrument, but you can understand that if you look straight down from the top of the upper control arm to the ground you would find that the ball joints do not line up (fore and aft) when a caster angle other than "0" is present. If you had a positive caster angle the lower ball joint would be slightly ahead of the upper ball joint center line. In short then: caster is the forward or backward tilt of the steering axis.

## STEERING AXIS INCLINATION (FIGURE 2)

Steering axis inclination is the inward tilt (at the top) of the steering knuckle from the vertical. The inward tilt, or inclination, of the knuckle tends to

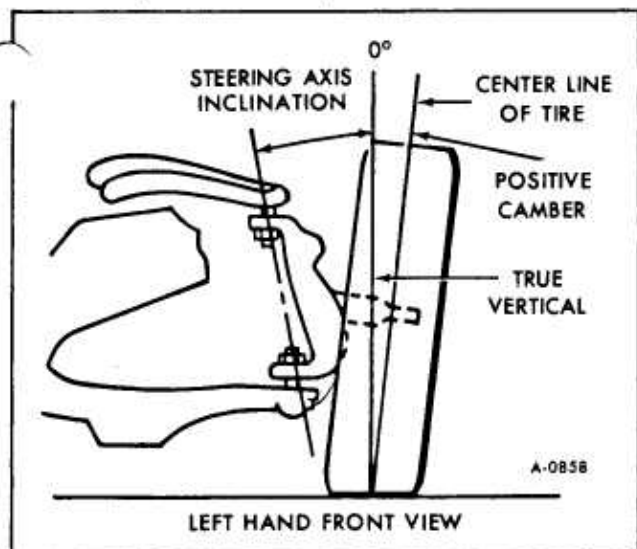

Figure 2—Steering Axis Inclination

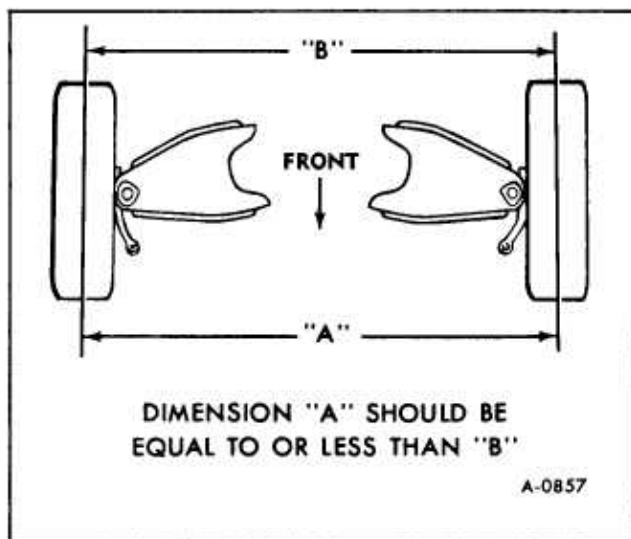
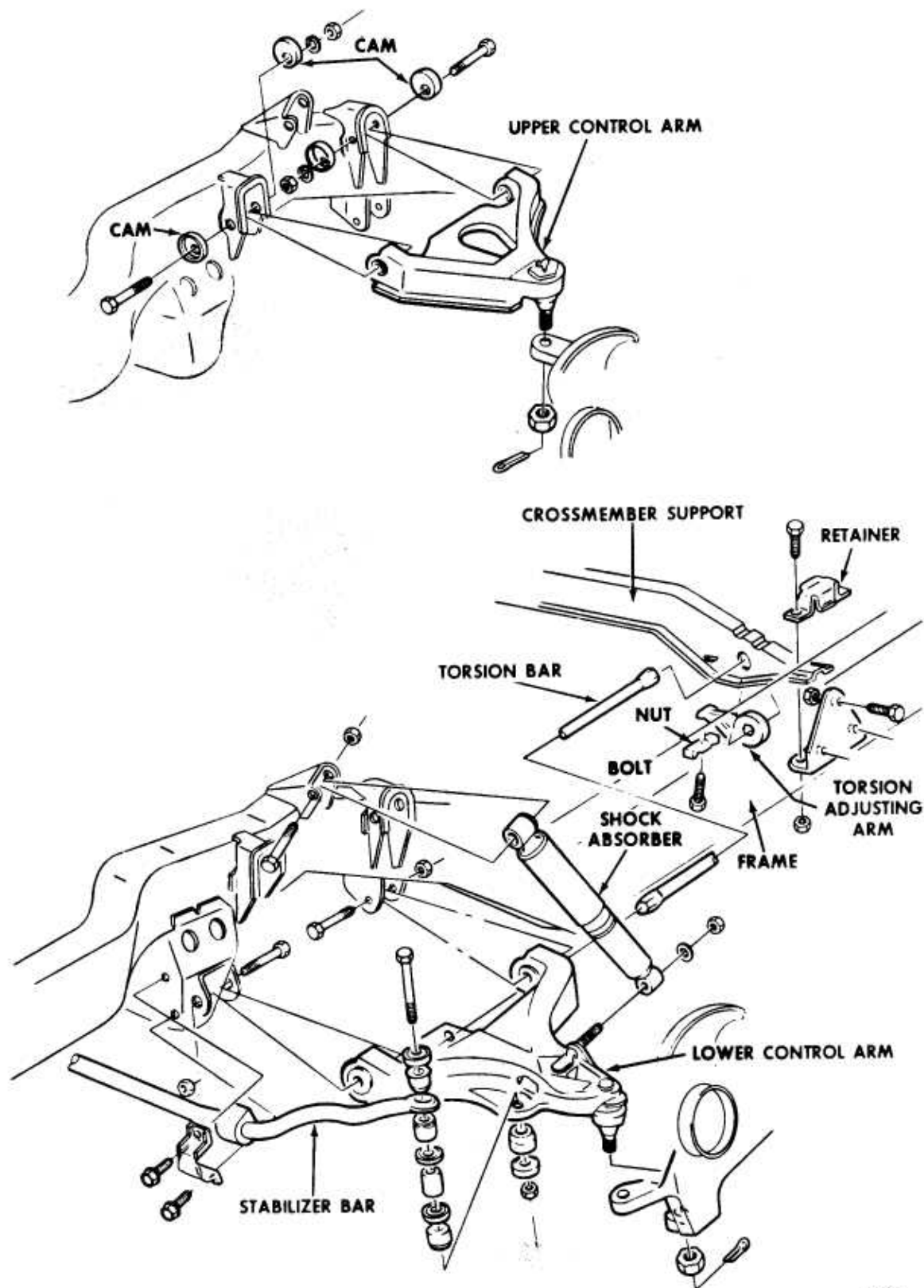

Figure 3—Toe-In

keep the wheels straight ahead. This is desirable because, it helps return the steering wheel straight ahead after a turn. This steering wheel return comes about because the vehicle is actually "LIFTED" when the wheels are swung away from the straight ahead position. Then the weight of the car tends to return the wheels straight ahead after a turn is completed.

## TOE-IN (FIGURE 3)

Toe-in is the turning in of the front wheels. The actual amount of toe-in is normally only a fraction of an inch. The purpose of toe-in is to ensure parallel rolling of the front wheels. (Excessive toe-in or toe-out will cause tire wear) Toe-in also serves to offset the small deflections of the wheel support system which occurs when the vehicle is rolling forward. In other words, even when the wheels are set to toe-in slightly when the vehicle is standing still, they tend to roll parallel on the road when the vehicle is moving.



A-0864

Figure 4-Front Suspension

## TOE-OUT ON TURNS

Toe-out on turns refers to the difference in angles between the front wheels and the vehicle frame during turns. Since the inner wheel turns a smaller radius than the outer wheel, when rounding a curve, it must be at a sharper angle with respect to the vehicle frame. That is it must toe-out more than the outside wheel toes-in. This condition is desirable because it allows the front wheels to turn in a concentric circle. Toe-out on turns is non-adjustable.

## GENERAL DESCRIPTION

The front suspension on the Motor Home consists of control arms, stabilizer bar, shock absorbers and a right and left torsion bar. Torsion bars are used instead of the conventional coil springs. The front end of the torsion bar is attached to the lower control arm. The rear of the torsion bar is mounted into an adjustable arm at the torsion bar crossmember. The carrying height of the Motor Home is controlled by this adjustment (Figure 4).

## DISC & HUB (FIGURE 6)

### REMOVAL

1. Siphon approximately two-thirds of the brake fluid from the front reservoir of the master cylinder. Discard fluid.

**NOTE:** Do not empty front reservoir or it will be necessary to bleed the brake system.

2. Hoist Motor Home and remove wheel.
3. Remove cotter pin, drive axle nut and washer.
4. Position Tool J-22269 or caliper as shown in Figure 5
5. Tighten screw of tool until caliper moves outboard far enough to push piston to bottom of piston bore. This will allow the shoes to back off from disc surface. Remove Tool J-22269.
6. Remove the two caliper to knuckle attaching bolts. (figure 12).
7. Carefully lift caliper assembly from disc and reposition so that brake hose is not kinked or stretched.
8. Loosen uniformly and remove the three bolts securing the retainer to the knuckle (figure 7).
9. Position Tool No. J-24717 on hub as shown in Figure 8.
10. Operate slide hammer Tool No. J-2619, until assembly is free of knuckle. See Figure 8.
11. Remove slide hammer and Tool No. J-24717.

### INSTALLATION

See CAUTION on Page 3A-1 of this section.

1. Lubricate O.D. of bearing with chassis grease.
2. The outer race of the bearing is a snug fit into the knuckle. Light tapping on the hubs outer surface (not the disc) will aid assembly. Care must be used when installing hub assembly over drive axle splines so that splines are in correct alignment.
3. Install three bolts attaching bearing retainer to knuckle Torque to 35 ft. lbs.
4. Install drive axle washer and nut. Torque nut to 110 ft. lbs. If necessary to align cotter pin slot, tighten nut and install NEW cotter pin and crimp. Torque not to exceed 280 ft. lbs.

**NOTE:** Do not back off nut to install cotter pin.

## HUB BEARING

### REMOVAL

1. Remove disc hub assembly. Refer DISC HUB ASSEMBLY-Removal.

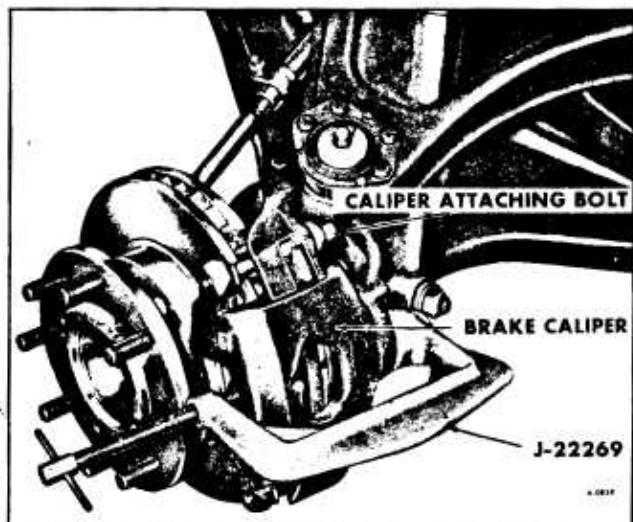

Figure 5-Caliper Removal

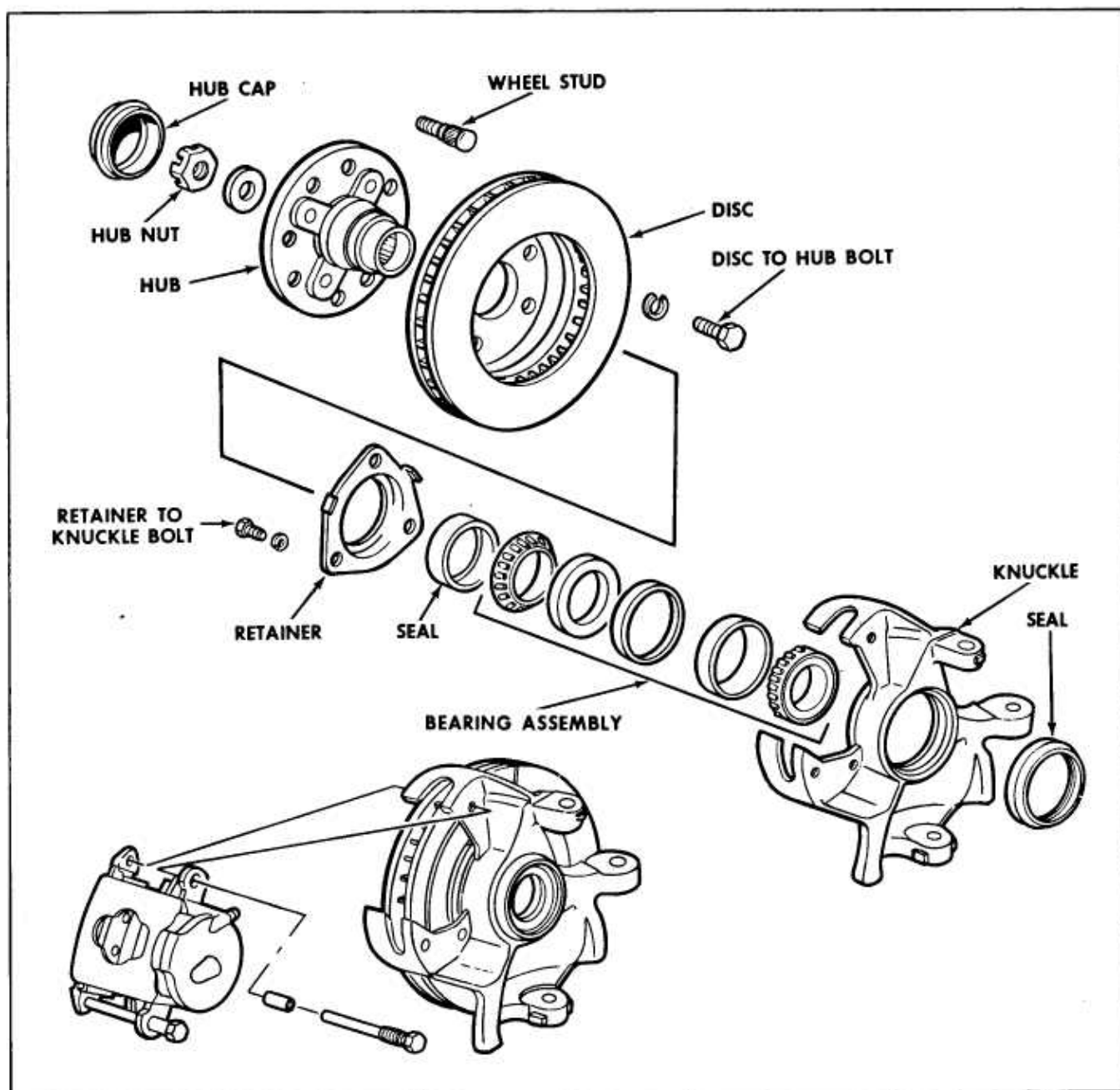

Figure 6-Disc and Hub Assembly

2. Assemble Tool No. J-23345 to Tool No. J-8433-1

3. Position tool assembly as shown in Figure 9.

4. With Tool No. J-22214-6 in place, and a clamp in position as shown in Figure 9, tighten center screw until bearing is free of hub.

5. Remove seal and retainer.

## INSTALLATION

See CAUTION on Page 3A-1 of this section.

1. Position retainer over hub.

2. Lubricate seal lips with Special Seal Lubricant No. 1050169 or equivalent then position seal over hub with metal end toward retainer.

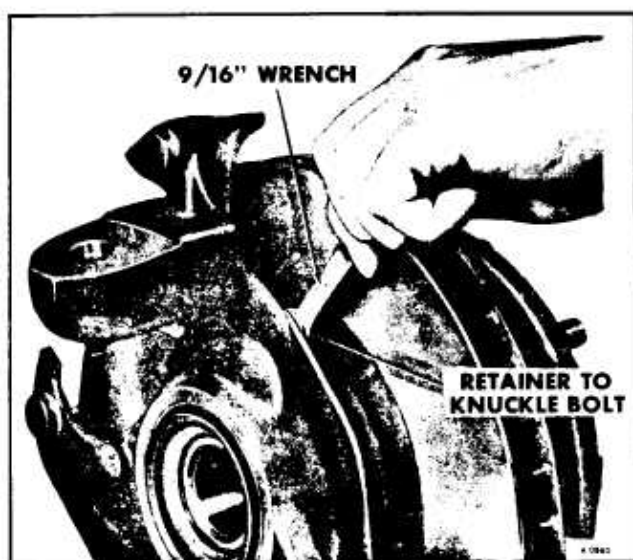

Figure 7—Retainer Bolt Removal

3. Install bearing as shown in Figure 11.

4. Install hub assembly. Refer to HUB ASSEMBLY-Installation.

## DISC

### REMOVAL (FIGURE 10)

1. Remove disc and hub assembly. Refer DISC and HUB ASSEMBLY-Removal.

2. Remove hub bearing. Refer HUB BEARING-Removal.

3. Remove (4) bolts and separate disc from hub as shown in Figure 10.

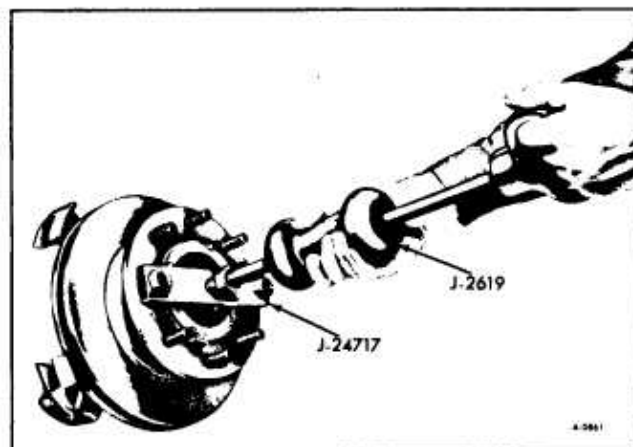

Figure 8—Hub and Disc Removal

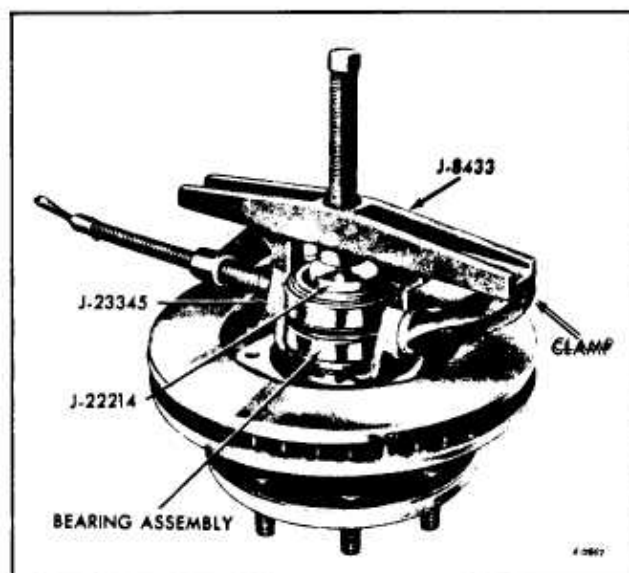

Figure 9—Bearing Removal

## INSTALLATION

1. Install (4) attaching bolts and torque to 35 ft. lbs.

2. Install hub bearing. Refer HUB BEARING-Installation.

3. Install disc and hub assembly. Refer DISC and HUB ASSEMBLY-Installation.



Figure 10—Disc Removal

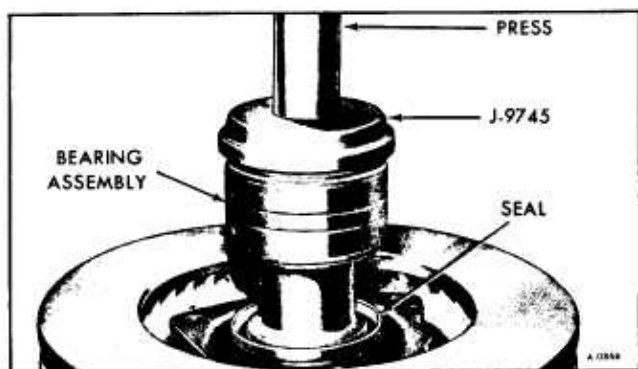

Figure 11—Installing Bearing

## KNUCKLE SEAL R.H.

### REMOVAL

1. Hoist Motor Home and place a floor stand on each side.
2. Remove drive axle cotter pin, nut and washer under the lower control arm.
3. Remove inner C.V. joint attaching bolts. Discard bolts.
4. Push inner C.V. joint outward enough to disengage from R.H. final drive output shaft and move rearward.
5. Remove R.H. output shaft support bolts to engine.
6. Remove R.H. output shaft.
7. Remove drive axle assembly.

**CAUTION:** Care must be exercised so that C.V. joints do not turn to full extremes and that seals are not damaged against shock absorber or stabilizer bar.

8. Pry seal from knuckle.

### INSTALLATION

See CAUTION on Page 3A-1 of this section.

1. Lubricate seal inner lips with Special Seal Lubricant No. 1050169 or equivalent.
2. Install Tool J-23115 into seal until metal O.D. of seal contacts tool.
3. Install seal into knuckle until tool bottoms. (figure 12).

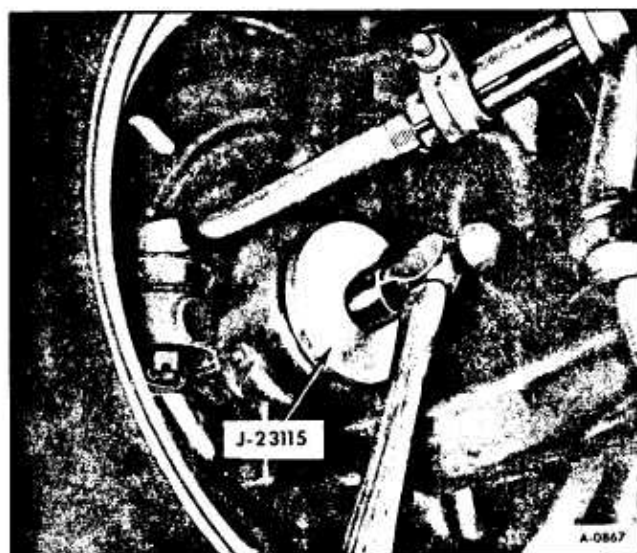

Figure 12—Installing Knuckle Seal

4. Carefully place R.H. drive axle assembly into lower control arm and enter outer race splines into knuckle.
5. Lubricate final drive output shaft seal with Special Seal Lubricant, No. 1050169 or equivalent.
6. Install R.H. output shaft into final drive and loosely attach support bolts to engine.

**NOTE:** When attaching the right hand output shaft to the engine, do not let the shaft hang. Assemble support bolts loosely, and by moving the flange end of the shaft up and down, and back and forth, find the center location. Hold the shaft in this position and then torque the bolts to 55 ft. lbs. on support.

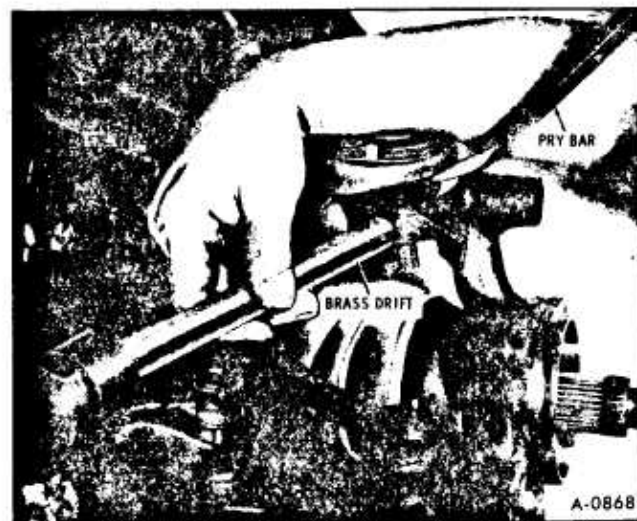

Figure 13—Removing Upper Ball Joint

7. Move R.H. drive axle assembly toward front of car and align with R.H. output shaft. Install NEW attaching bolts and torque to 65 ft. lbs.

8. Install washer and nut on drive axle. Torque to 110 ft. lbs. tighten to next slot. Insert NEW cotter pin and crimp. Torque not to exceed 280 ft. lbs.

**NOTE:** Do not back off nut to install NEW cotter pin.

9. Remove floor stands and lower hoist.

## KNUCKLE SEAL L.H.

### REMOVAL

1. Hoist Motor Home and place a floor stand on each side under the lower control arm.

2. Remove wheel.

3. Remove drive axle cotter pin, nut and washer.

4. Remove tie rod end cotter pin and nut.

5. Using Tool J-24319 remove tie rod end.

6. Remove upper control arm ball joint cotter pin and nut. Remove brake hose clip from ball joint stud.

7. Using hammer and brass drift, drive on knuckle until upper ball joint stud is free. (figure 13).

8. Using Tool J-24319 remove lower ball joint from knuckle. Care must be exercised so that ball joint doesn't damage drive axle seal.

9. Remove knuckle. Support knuckle so that brake hose is not damaged.

10. Pry seal from knuckle.

### INSTALLATION

See CAUTION on Page 3A-1 of this section.

1. Lubricate seal inner lips with Special Seal Lubricant No. 1050169 or equivalent.

2. Install Tool J-23115 into seal until metal O.D. of seal contacts tool.

3. Install seal into knuckle until tool bottoms (figure 12).

4. Insert lower control ball joint stud into knuckle and attach nut. Do not torque.

5. Center L.H. drive axle assembly into splines of hub and insert upper ball joint stud.

6. Place brake hose clip over upper ball joint stud and install nut. Do not torque.

7. Insert tie rod end stud into knuckle and attach nut. Torque to 40 ft. lbs. Install NEW cotter pin and crimp. Do not back off nut to install cotter pin.

8. Torque upper ball joint stud nut to 50 ft. lbs. min. Tighten to align cotter pin.

**CAUTION:** *Upper ball joint cotter pin must be crimped toward upper control arm to prevent interference with outer C.V. joint seal.*

9. Torque lower ball joint stud nut to 100 ft. lbs. min. Tighten to align NEW cotter pin.

10. Install drive axle washer and nut. Torque to 110 ft. lbs. tighten to next slot. Install NEW cotter pin and crimp. Torque not to exceed 280 ft. lbs.

**NOTE:** Do not back off nut to install NEW cotter pin.

11. Install wheel, remove floor stands, and lower hoist.

## KNUCKLE

### REMOVAL

1. Remove disc hub assembly (refer to DISC HUB ASSEMBLY, REMOVAL).

2. Remove upper ball joint cotter pin and nut.

3. Remove brake line hose clip from ball joint stud.

**NOTE:** Do not loosen ball joint stud.

4. Using a brass drift and hammer, Figure 13, loosen upper ball joint stud.

5. Remove cotter pin and nut from tie rod end.

6. Using Tool J-24319 remove tie rod end as shown in Figure 14.

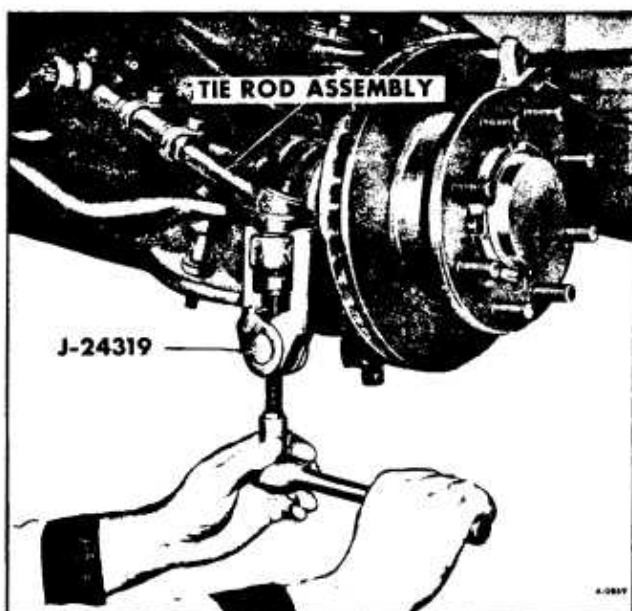

Figure 14—Removing Tie Rod End

7. Remove cotter pin and nut from lower ball joint.
8. Using Tool J-24319; remove lower ball joint from knuckle (figure 15).
9. Remove knuckle. Pry seal from knuckle.

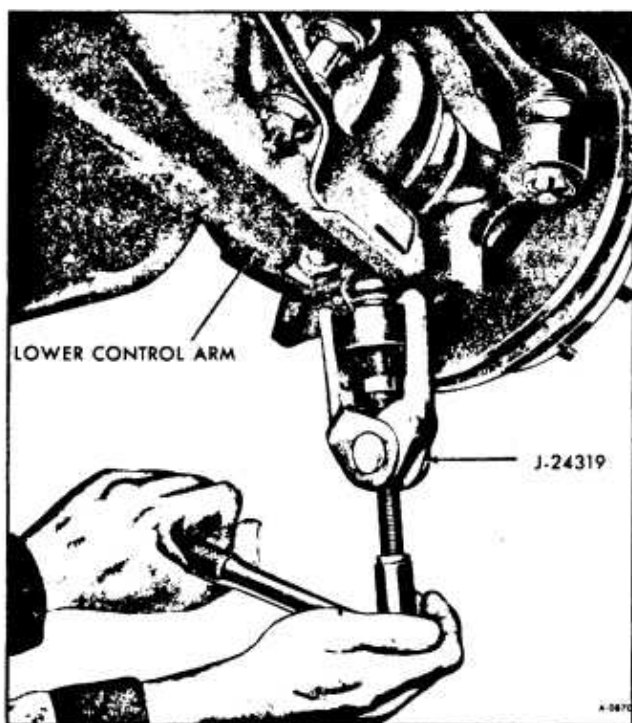

Figure 15—Removing Lower Ball Joint

## INSTALLATION

See CAUTION on Page 3A-1 of this section.

1. Using Tool J-23115 install seal into knuckle.
2. Install lower ball joint stud into knuckle and attach nut. Do not torque.
3. Install tie rod end stud into knuckle and attach nut. Do not torque.
4. Install upper ball joint stud into knuckle and attach brake line hose clip. Install nut.
5. Torque ball joint nut to a minimum of 50 ft. lbs. (upper), 100 ft. lbs. (lower). Tighten to install NEW cotter pins.

**CAUTION:** *Cotter pin on upper ball joint must be bent up only to prevent interference with C.V. joint seal.*

6. Torque tie rod end nut to 40 ft. lbs. and install NEW cotter pin.

**NOTE:** Do not back off nut to install NEW cotter pin.

7. Install disc hub assembly (refer to DISC HUB ASSEMBLY INSTALLATION).

## UPPER CONTROL ARM

### REMOVAL

1. Hoist Motor Home and remove wheel, and place a floor stand on each side under and firmly against the lower control arm.
2. Remove upper shock attaching bolt.
3. Remove cotter pin and nut from upper ball joint.
4. Disconnect brake hose clamp from ball joint stud.
5. Using hammer and a drift, Figure 13, drive on spindle until upper ball joint stud is disengaged.
6. Remove upper control arm cam assemblies and remove control arm from Motor Home by guiding shock absorber through access hole in arm.



## INSTALLATION

See **CAUTION** on Page 3A-1 of this section.

**NOTE:** Service upper control arm assemblies have plugs instead of grease fittings in ball joints. Remove plugs and install grease fittings before installing control arm.

1. Guide upper control arm over shock absorber and install bushing ends into frame bracket.
2. Install cam assemblies as shown in Figure 4.
3. Install ball joint stud into knuckle.
4. Install brake hose clip on ball joint stud.
5. Install ball joint nut. Torque to 50 ft. lbs. Insert **NEW** cotter pin and crimp.

**NOTE:** Do not back off nut to install **NEW** cotter pin.

**CAUTION:** *Cotter pin must be crimped toward upper control arm to prevent interference with outer C.V. joint seal.*

6. Install upper shock attaching bolt and nut. Torque nut to 90 ft. lbs.
7. Install wheel and remove floor stands.
8. Lower hoist.
9. Check camber, caster and toe-in and adjust if necessary. Refer to **FRONT END ALIGNMENT**.

## UPPER CONTROL ARM BUSHING (ON MOTOR HOME)

Upper control arm bushings can be removed and installed on or off the Motor Home.

### REMOVAL

1. Hoist vehicle, place floor stands under and firmly against the lower control arm, and remove wheel.
2. Disconnect upper shock absorber attaching bolt. (figure 18)
3. Remove cam assemblies from control arm.
4. Move control arm out of frame brackets and attach bushing removal tools as shown in Figure 19.

## INSTALLATION

See **CAUTION** on Page 3A-1 of this section.

1. Install Tools as shown in Figure 20 and press bushings into control arm.
2. Move control arm into frame brackets and install cam assemblies. The cams are installed with the bolts in the lower position. Torque nut to 110 ft. lbs.
3. Connect upper shock attaching bolt. Torque nut to 90 ft. lbs.
4. Replace wheel, remove floor stands, lower hoist.
5. Align front wheels. Refer to **FRONT END ALIGNMENT**.

## LOWER CONTROL ARM

### REMOVAL

1. Hoist Motor Home and remove wheel assembly.
2. Before using Tool J-22517, remove two nuts and center screw, then place tool over crossmember support. Align pin of tool into hole in crossmember. Install two nuts on tool and center screw: Turn center screw until seated in dimple of torsion adjusting arm. (figure 16)
3. Using a socket on the torsion bar adjusting bolt, turn counterclockwise, counting the number of turns necessary to remove.

**NOTE:** The number of turns to remove the adjusting bolt will be used when installing, to obtain the original carrying height.

4. Remove adjusting bolt and nut.
5. Turn center screw of Tool J-27517 until torsion bar is completely relaxed and remove torsion bar noting which end is front.
6. Disconnect shock absorber and stabilizer link from lower control arm.
7. Remove drive axle nut.
8. Remove cotter pin and nut from lower ball joint stud.

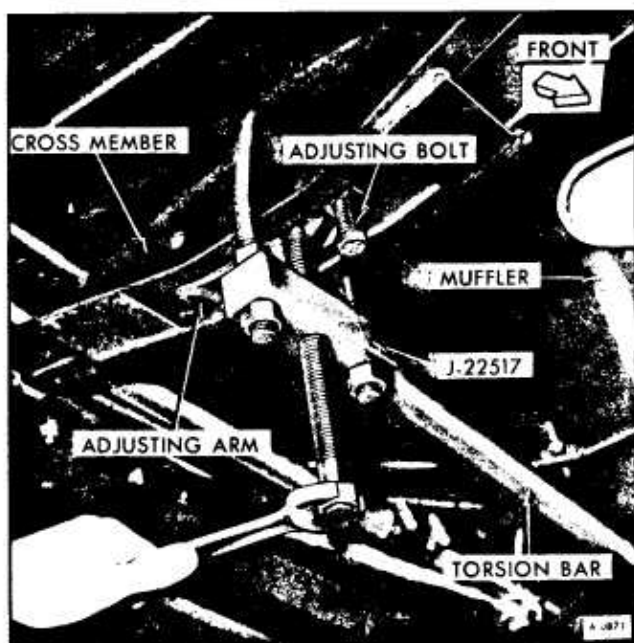

Figure 16—Removing Torsion Bar

9. Install Tool J-24319 and remove ball joint stud from knuckle. (figure 15)

10. Remove bolts from lower control arm to frame and remove torsion bar.

11. Push inboard on drive axle and pull outward on knuckle to gain clearance, then remove lower control arm from knuckle.

## INSTALLATION

See CAUTION on Page 3A-1 of this section.

1. Install lower control arm making certain shock absorber is guided onto lower control arm shock absorber mount. Guide ball joint stud into knuckle. Install but do not torque stud nut.

2. Install lower control arm to frame bracket bolts. Install nuts and torque to 90 ft.-lbs.

3. Torque lower ball joint stud to 100 ft. lbs.

**NOTE:** Do not back off nut to install NEW cotter pin.

4. Install shock absorber nut and torque to 90 ft. lbs. Install stabilizer link and torque nut to 15 ft. lbs.

5. Apply a liberal amount of chassis grease to both ends and place front end of torsion bar into

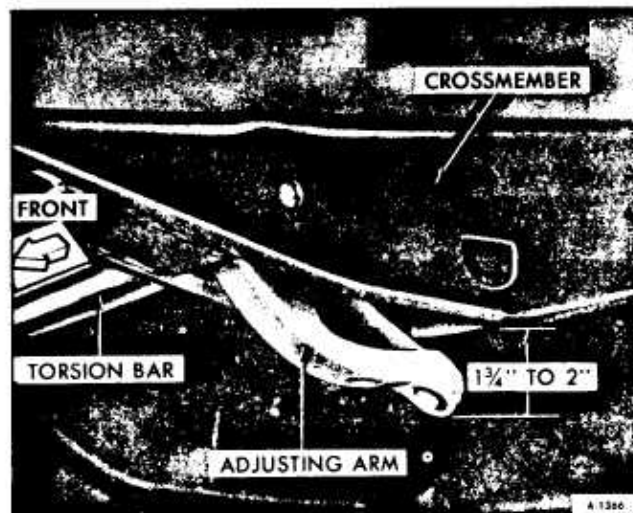

Figure 17—Positioning of Adjusting Arm

control arm. Push torsion bar all the way forward into the control arm.

6. Insert adjusting arm into the crossmember and position to 1-3/4" - 2" below the centerline of the crossmember (see figure 17). Slide torsion bar rearward until it is flush with the rear face of the adjusting arm.

7. Reposition Tool J-22517 making sure pin of tool is in hole in crossmember. Turn center screw of Tool J-22517 until adjusting arm is in position to allow installation of the adjusting nut.

8. Apply a liberal amount of chassis grease and install adjusting bolt and turn number of turns previously recorded to obtain original ride height.

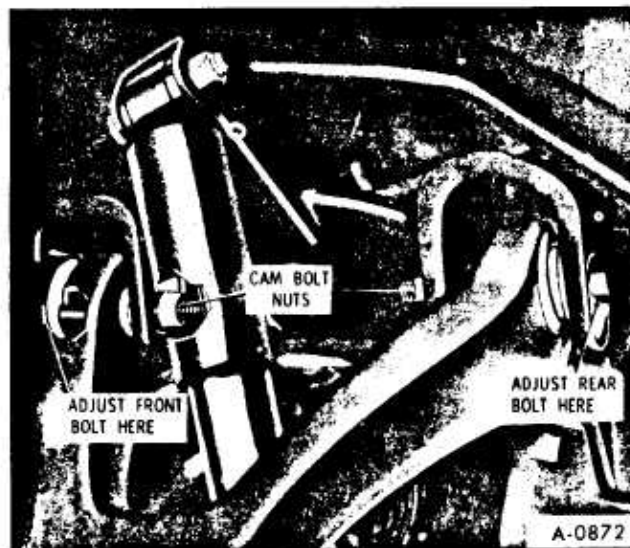

Figure 18—Upper Control Arm Attachment

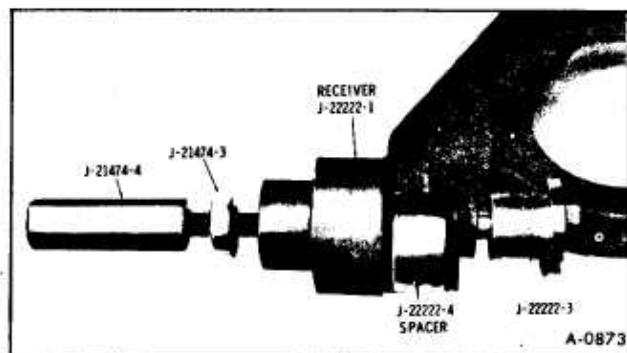

Figure 19—Removing Upper Control Arm Bushing

9. Turn center screw until torsion is relaxed and remove tool.

10. Lower Motor Home.

11. Check ride height (see figure 31) Adjust if necessary refer to "RIDE HEIGHT" in this section.

## LOWER CONTROL ARM BUSHING REMOVAL

1. Hoist Motor Home.

2. Remove stabilizer link bolt. Discard bolt.

3. Place floor stands under frame horn, and under points where frame sections are bolted. Lower front lift to floor.

4. Install Tool J-22517. Method for attaching, refer to TORSION BAR REMOVAL, Item 2 through 6.

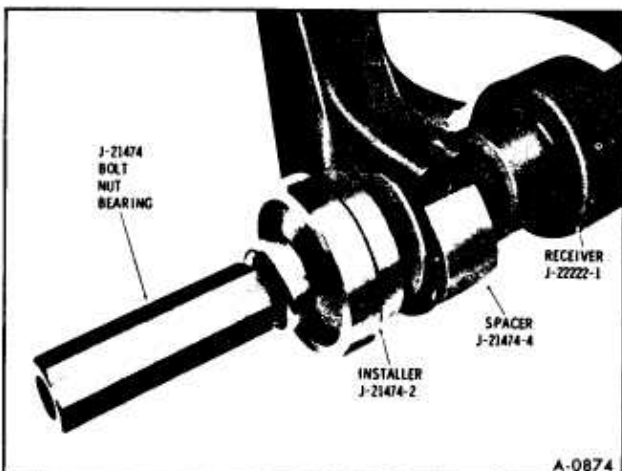

Figure 20—Installing Upper Control Arm Bushing

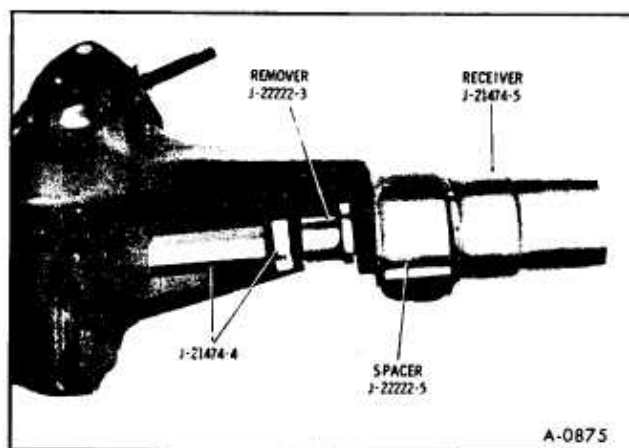

Figure 21—Removing Lower Control Arm Rear Bushing

5. Remove lower control arm bushing bolts and pull control arm down until free of frame brackets.

6. Install Tools through rear bushing and press out bushing as shown in Figure 21.

**NOTE:** Due to the torsion bar anchor attachment to the lower control arm, it will be necessary to use a hardened 1/2" x 20 nut as shown in Figure 22 to remove the front bushing.

## INSTALLATION

See CAUTION on Page 3A-1 of this section.

1. Install Tools as shown in Figure 24 and press rear bushing into lower control arm.

**NOTE:** Due to the torsion bar anchor attachment to the lower control arm, it will be necessary to use a hardened 1/2" x 20 nut as shown in Figure 23 to install the front bushing.

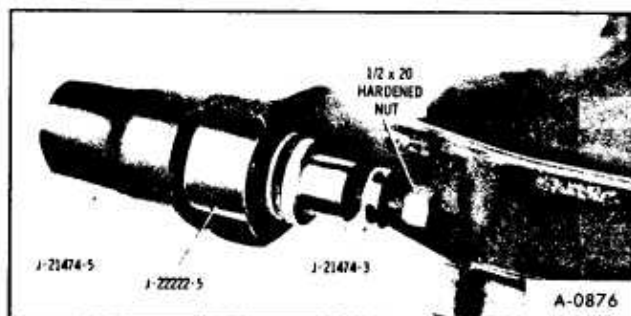

Figure 22—Removing Lower Control Arm Front Bushing

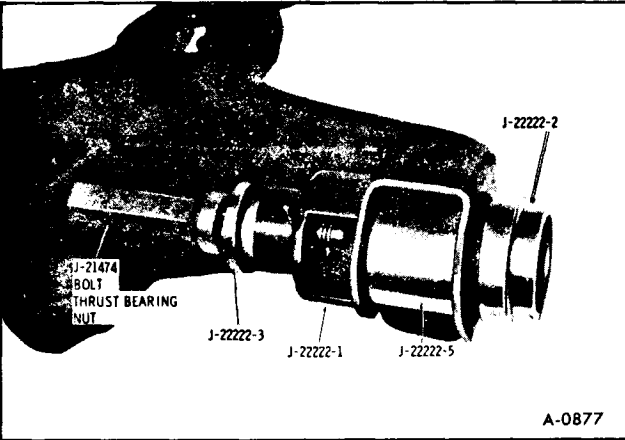

Figure 23—Installing Lower Control Arm Front Bushing

2. Raise lower control arm into frame brackets and install bushing bolts and nut. Do not torque.
3. Using Tool J-22517 Refer to TORSION BAR INSTALLATION, Item 10 through 13.
4. Raise front lift and remove floor stands.
5. Using a new bolt attach stabilizer link bolt to lower control arm. Torque nut to 15 ft. lbs. Cut bolt off 1/4" below nut.
7. Lower and torque lower control arm bushing nuts to 90 ft. lbs.

## BALL JOINT

Ball joint lubrication and seal inspection is important, refer to Section 0 for specifications and maintenance intervals.

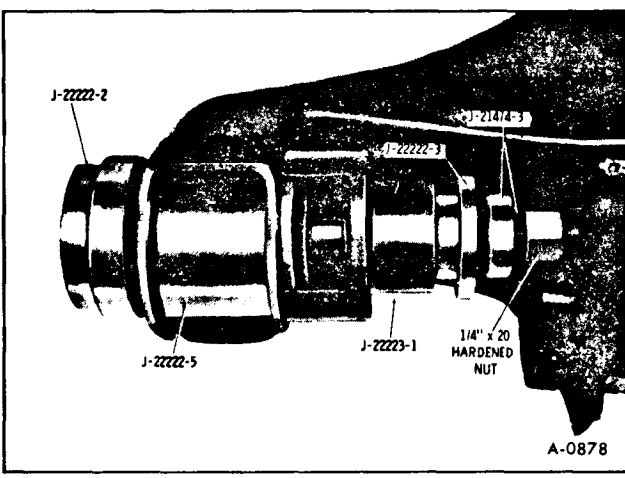

Figure 24—Installing Lower Control Arm Rear Bushing

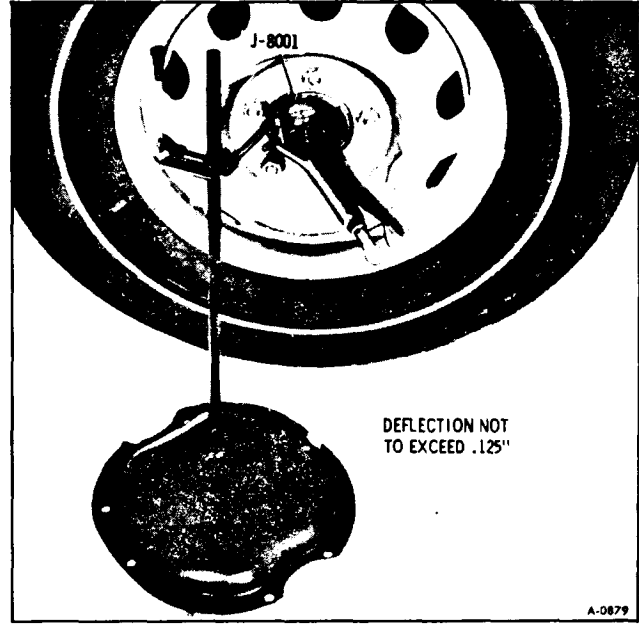

Figure 25—Ball Joint Vertical Check

## BALL JOINT CHECKS

### VERTICAL CHECKS

1. Raise the Motor Home and position floor

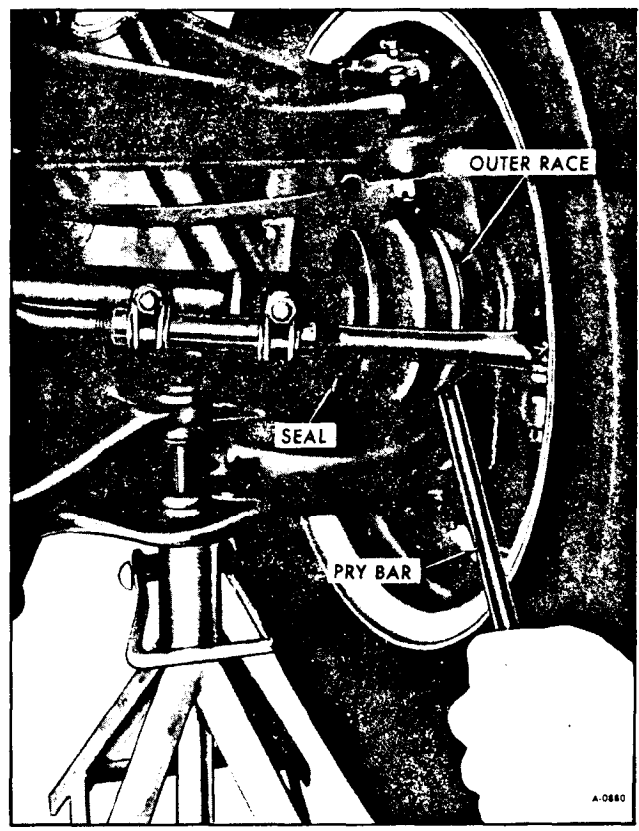

Figure 26—Pry Bar Installation

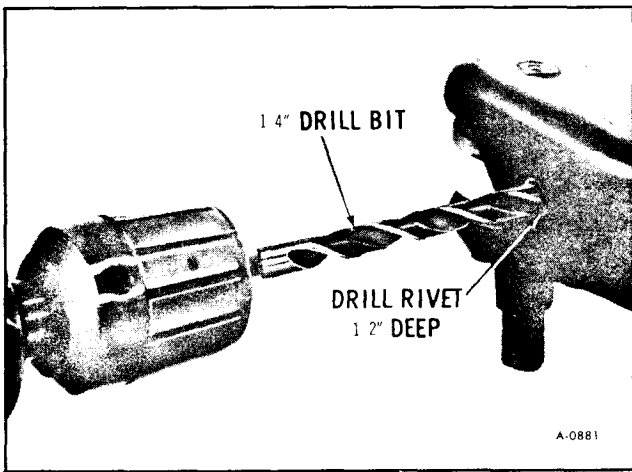

Figure 27-Drilling Ball Joint Rivets

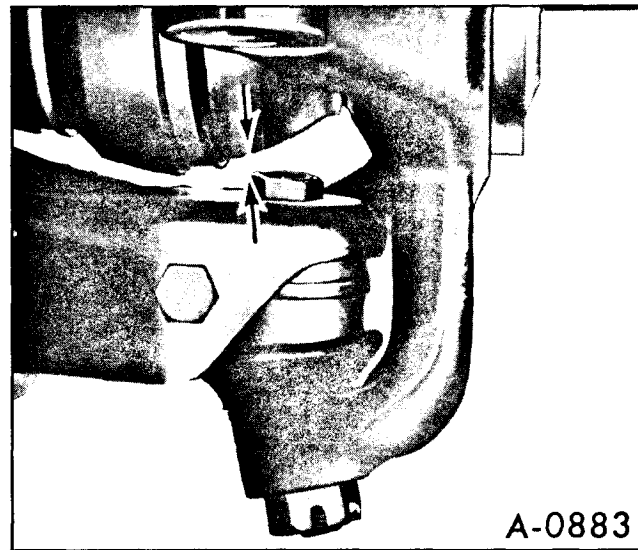

Figure 29-Checking Clearance

stands under the left and right lower control arms as near as possible to each lower ball joint. Motor Home must be stable and should not rock on the floor stands. Lower front hoist.

2. Position dial indicator as shown in Figure 25.

3. Place a pry bar as shown in Figure 26 and pry down on bar. Care must be used so that drive axle seal is not damaged. Reading must not exceed .125"

## LOWER CONTROL ARM BALL JOINT

### REMOVAL

1. Remove knuckle. Refer to **KNUCKLE REMOVAL**.

2. Drill side rivets 1/2" deep using 1/4" (figure

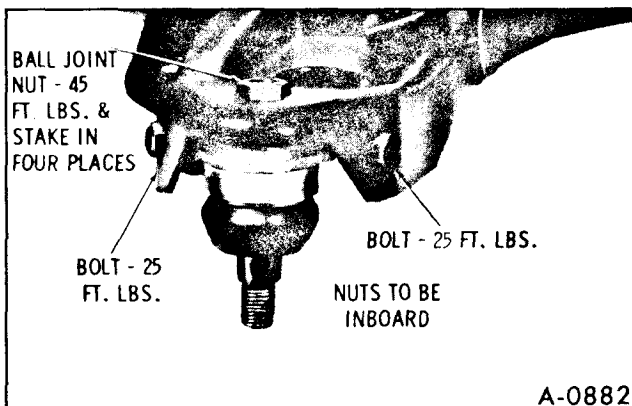

Figure 28-Installing Service Ball Joints

27) drill bit. Drill same rivets again with 1/2" drill bit just deep enough to remove head of rivet.

3. Drive out rivets with hammer and punch.

4. Drill center rivet using 5/8" drill bit just deep enough to remove rivet head.

5. Using hammer and punch, drive center rivet of joint until joint is out of control arm.

### INSTALLATION

See **CAUTION** on Page 3A-1 of this section.

1. Install service ball joint into control arm and torque bolts and nut as shown in Figure 28.

2. Install knuckle - Refer to **KNUCKLE INSTALLATION**.

3. Check clearance from ball joint nut to drive axle outer joint as shown in Figure 29. If no clearance is obtained, it may be necessary to grind off nut but not more than 1/16".

## UPPER CONTROL ARM BALL JOINT

### REMOVAL

1. Hoist Motor Home under lower control arms and remove wheel.

2. Remove cotter pin and nut from upper ball joint stud.

3. Disconnect brake hose clip from upper ball joint stud.

4. Using hammer and a brass drift similar to Figure 13 drive on spindle until upper ball joint stud is disengaged from spindle.

5. Raise control arm up and drill rivets with a 1/8" drill bit 3/8" deep.

**NOTE:** It may be necessary to use a block of wood between frame and control arm for support.

6. Drill off rivets using a 1/2" drill bit. Do not drill into control arm.

7. Using a punch, drive out rivets and remove ball joint.

## INSTALLATION

See **CAUTION** on Page 3A-1 of this section.

1. Install service ball joint into control arm (bolts must be installed from top side). Torque nuts to 20 ft. lbs.

2. Install ball joint stud into knuckle and position brake hose clip over stud.

3. Install ball joint stud nut and torque to 50 ft. lbs. Tighten to install **NEW** cotter pin.

**CAUTION:** *Cotter pin must be bent up to prevent interference with outer C.V. Joint Seal.*

4. Install wheel and lower hoist.

## STABILIZER BAR

### REMOVAL

1. Remove link bolts, nuts, grommets, spacers and retainers from lower control arm. Discard bolts.

2. Remove two bolts attaching dust shield to frame (both sides).

3. Remove bracket to frame attaching bolts and remove stabilizer bar from front of car.

## INSTALLATION

See **CAUTION** on Page 3A-1 of this section.

Reverse removal procedure.

**NOTE:** New link nuts are torqued to 15 ft. lbs. then bolt is cut off 1/4" below nut.

## SHOCK ABSORBER (FIGURE 4)

### REMOVAL

1. Raise Motor Home and place a safety stand under and firmly against the lower control arm.

**CAUTION:** *This must be done to prevent the lower control arm from shifting and damaging the tie rod.*

2. Remove wheel.

3. Remove upper shock attaching bolt.

4. Remove lower shock attaching nut and carefully guide shock through upper control arm.

### INSTALLATION

1. Guide shock absorber through upper control arm and onto lower shock mounting stud.

2. Extend shock towards upper mount as necessary and install bolt. Torque to 90 ft. lbs.

3. Install lower shock mounting nut and torque to 90 lbs.

4. Install wheel and replace wheel nuts finger tight.

5. Remove safety stands and lower Motor Home. Torque wheel nuts 280 ft. lbs.

## TORSION BAR AND/OR CROSSMEMBER SUPPORT

### REMOVAL

1. Raise Motor Home on a twin post hoist.

2. Remove two nuts and center screw from Tool J-22517. Position tool over crossmember installing

pin of tool into hole in crossmember. Install two nuts on tool, install center screw. Grease center screw threads and the rounded end of the screw with chassis grease.

3. Turn center screw until seated in dimple of torsion bar adjusting arm. See Figure 16.

4. Remove torsion bar adjusting bolt and nut. Count the number of turns necessary to remove and record.

**NOTE:** The number of turns to remove the adjusting bolt will be used when installing to obtain the original carrying height.

5. Turn center screw of Tool J-22517 until torsion bar is completely relaxed.

6. Remove Tool J-22517.

7. Repeat steps 2, 3, 4, 5 and 6 on opposite torsion bar.

8. Remove bolts and retainer from torsion bar crossmember at frame (figure 4).

9. Disconnect exhaust pipe hanger from crossmember and loosen pipe saddle and "U" clamp. Slide hanger backward.

10. Move crossmember rearward until torsion bars are free and adjusting arms are removed.

11. Move torsion bar crossmember sideways to the extreme left. Move crossmembers upward and outward until opposite end clears exhaust pipe.

12. Remove torsion bars. Mark accordingly to insure proper installation end for end and right and left.

5. Insert torsion bar adjusting arm into crossmember, position so the arm will engage the torsion bar and the end of the arm will be 1-3/4"-2" below the crossmember (see figure 17). Tap crossmember forward enough to engage bar into arm.

6. Repeat step 5 for the other side of vehicle.

7. Position crossmember to its normal position. Torsion bars should be through and flush with rear face of the adjusting arm. If not repeat steps 5 and 6 after pulling torsion bar slightly out from the lower control arm.

8. Install retainer over each insulator and torque nut to 10 ft. lbs.

9. Reposition and connect exhaust pipe hanger to crossmember and tighten saddle and "U" clamp. Torque nuts 15 ft. lbs.

10. Position Tool J-22517 over crossmember installing pin of tool into hole in crossmember. Install two nuts on tool, install center screw.

11. Turn center screw until adjusting arm is in a position to allow installation of adjusting nut. See Figure 16.

12. Install nut and turn adjusting bolt the recorded number of turns to obtain previous ride height.

13. Turn center screw until torsion is completely relaxed. Remove tool and repeat step 10, 11, 12, 13 on the opposite side.

14. Lower hoist.

15. If ride height requires adjustment refer to "RIDE HEIGHT" following this procedure.

## INSTALLATION

1. Install torsion bars. New torsion bars are stamped on one end with an "R" for right or an "L" for left side. Apply a liberal amount of chassis grease to both ends.

2. Install crossmember insulators on the crossmembers.

3. Install crossmember and position approximately 2 inches rearward of its normal position.

4. Raise torsion bars and align with hole in crossmember. Move crossmember forward so torsion bars rests on edge of hole.

## RIDE HEIGHT

When checking front ride height, the Motor Home parked on a known level surface, and tire pressure at specified psi.

**NOTE:** For details on adjusting rear ride height refer to Section 4, REAR SUSPENSION. If vehicle is equipped with the optional Power Level System, be sure power level control knobs are set in the "TRAVEL" position prior to adjusting front ride height.

Measurements must be taken from the oval hole in the frame rail to the floor (figure 31). **NOTE:** Never attempt to increase the ride height of the Motor Home using the adjusting bolt (figure 30) while

## FRONT END ALIGNMENT

The Motor Home must be on a level surface, and tires both front and rear inflated to 60 psi.

1. Check the ride height dimension (figure 31). If not within specifications refer to "RIDE HEIGHTS" in this section.

2. Using available wheel alignment equipment CHECK caster, camber and toe-in settings. Specifications are:

	Check	Set
Caster .....	+2° to +3°	+3°
Camber-L.H. ....	+1/2° to 1°	+3/4°
Camber-R.H. ....	+1/4° to 1°	+1/2°
Toe-In .....	-1/8" to +1/8"	0

Make adjustments as required. Refer to "ALIGNMENT ADJUSTMENT" below.

## ALIGNMENT ADJUSTMENT

## Camber

1. Loosen nuts on inboard side of upper control arm cam bolts. (Figure 4).

2. Turn front cam bolt (inboard or outboard) to correct for 1/2 of incorrect setting found in checking.

3. Turn rear cam bolt (same way front bolt was turned) to correct for remaining 1/2 of incorrect setting found in checking.

Example:

Camber Reading (Checking).....	+1 1/4°
Amount To Be Corrected .....	1/2°
1/2 of 1/2° = 1/4° Front Cam Bolt	

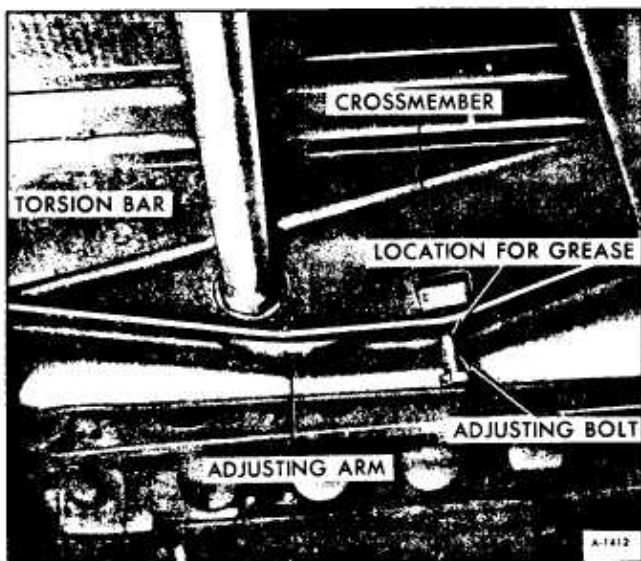

Figure 30—Location For Front Ride Height Adjustment

the vehicle is on the ground. The bolt will turn but will strip threads and will necessitate replacement of the bolt.

The procedure to adjust the ride height is as follows:

1. Raise vehicle.

2. To raise the ride height.

a. Clean off adjusting bolt with a wire brush. Apply chassis grease to threads. NOTE: Failure to use lubricant will strip the threads on the bolt.

b. Turn bolt clockwise.

c. Lower vehicle, check height, turn bolt counter-clockwise to lower if required.

3. To lower the vehicle.

a. Turn adjusting bolt counter-clockwise as required to obtain proper ride height.

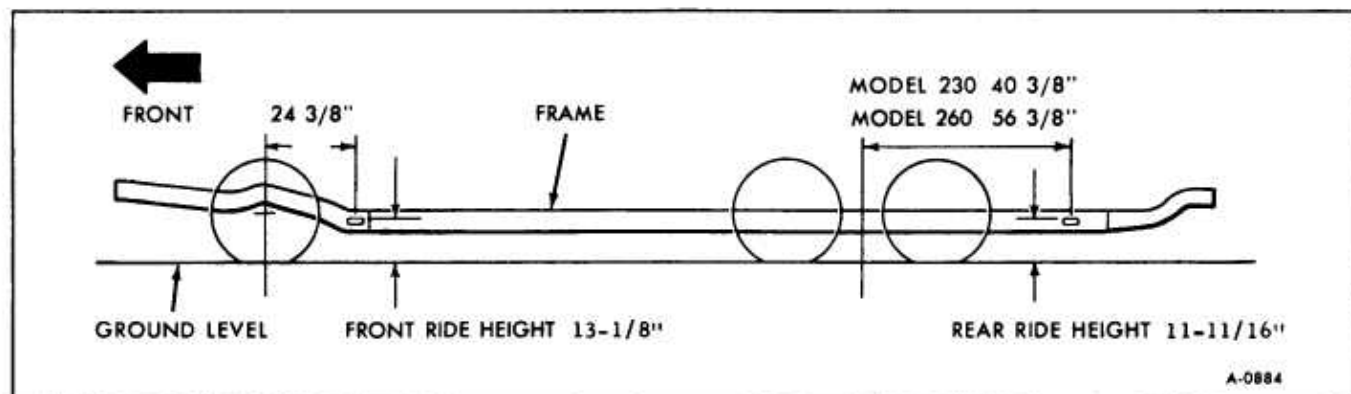

Figure 31—Motor Home Ride Height



### Remaining 1/4° Rear Cam Bolt

4. Tighten front and rear cam nuts while holding bolts with back-up wrench so that camber is not changed. Check caster, do not reset unless caster exceeds specifications.

### Caster

1. Loosen front and rear cam nuts while holding bolts with back-up wrench so that camber is not changed.

2. Turn front cam bolt so that camber changes 1/4 of the desired amount of caster to be corrected.

#### Example:

Caster Reading (Checking) ..... +5°  
 Amount To Be Corrected ..... 2°  
 1/4 of 2° = 1/2° Front Cam Bolt

3. Turn rear cam bolt so that camber now returns to corrected setting.

4. Recheck caster setting.

This is a location to start from and a correct setting can be obtained with the above procedure.

**NOTE:** Torque upper control arm cam nuts to 110 ft. lbs. Hold head of bolt securely, any movement of the cam will effect the final setting and caster camber adjustment must be rechecked.

### Toe-In Adjustment (Figure 32)

1. Loosen the clamp bolts at each end of the steering tie rod adjustable sleeves. Tie rod assembly must be decreased in length in order to increase toe-in.

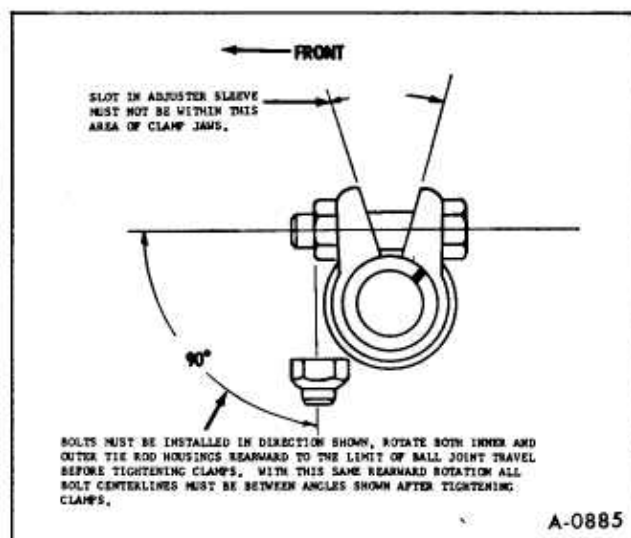

Figure 32-Positioning Tie Rod Clamp

**NOTE:** Tie rod adjuster components often become rusted in service. In such cases, it is recommended that if the torque required to remove the nut from the bolt (after breakaway) exceeds 7 ft. lbs., discard the nuts and bolts. Apply penetrating oil between the clamp and tube and rotate the clamps until they move freely. Install new bolts and nuts to assure proper clamping at the specified nut torque.

2. With steering wheel set in straight ahead position, turn tie rod adjusting sleeves to obtain the proper toe-in adjustment at curb load.

3. When adjustment has been completed according to the recommended specifications, check to see that the number of threads showing on each end of sleeve are equal and that the tie rod end housings are at right angles to steering arm. Position inner and outer tie rod clamps as shown in Figure 32. Torque nuts to 20 ft. lbs.

## TORQUE SPECIFICATIONS

APPLICATION	FT. LBS.
Drive axle Nut (Nut must be tightened to insert cotter pin) .....	110
Hub to Disc Bolts .....	35
Stabilizer Link Nut .....	15
Stabilizer Bracket to Frame Screw .....	25
Torsion Bar Crossmember Retainer Bolts .....	10
Shock Absorber	
Upper Nut .....	90
Lower-Nut .....	90
Lower Control Arm Bushing Nuts .....	90
Upper Control Arm Bushing Nuts.....	110
Ball Joint - Upper (Nut must be tightened to insert cotter pin) .....	50
Ball Joint - Lower (Nut must be tightened to insert cotter pin) .....	100
Tie Rod to Knuckle Nut (Nut must be tightened to insert cotter pin).....	40
Inner C.V. Joint to Output Shaft Bolts .....	65
Bearing Retainer to Knuckle Bolts .....	35

**SPECIAL TOOLS**

J-2619	Slide Hammer
J-8433-1	Bearing Puller
J-9745	Front Hub Bearing Installer
J-21474-3-4-5	Control Arm Bushing Remover and Installer
J-22214-4-6	Front Hub Bearing Screw and Adapter
J-23345	Front Hub Bearing Puller
J-22269	Brake Caliper Collapser
J-22517	Torsion Bar Unloader
J-23115	Front Hub Seal Installer
J-24319	Pitman Arm, Idler Arm, Ball Joint Puller
J-24717	Front Hub Puller

## SECTION 3B

# DRIVE AXLES

**CAUTION:** *The drive axle fasteners are an important attaching part in that they could affect the performance of vital components and systems, and/or could result in major repair expense. They must be replaced with one of the same part number or with an equivalent part if replacement becomes necessary. Do not use a replacement part of lesser quality or substitute design. Torque values must be used as specified during reassembly to assure proper retention of this part.*

Contents of this section are listed below:

SUBJECT	PAGE NO.
Trouble Diagnosis .....	3B-1
General Description.....	3B-2
Drive Axle Assembly (Right Hand).....	3B-2
Drive Axle Assembly (Left Hand).....	3B-3
Constant Velocity Joint.....	3B-5
Torque Specifications.....	3B-12
Special Tools .....	3B-12

## TROUBLE DIAGNOSIS

Problem	Possible Cause	Correction
Clicking noise in turns.	Excessive wear or broken outboard joint.	Inspect and replace outboard joint if necessary.
Coast to drive "CLUNK".	Loose inboard joint flange bolts.	Tighten to specified torque.
Shudder or vibration on acceleration.	Excessive wear on inboard joint housing. Worn spider assembly.	Check for brinelling of housing bores and replace if necessary. Check for wear or free rotation of balls on spider. Replace joint assembly if necessary.
Shimmy vibration at highway speeds.	Tires out of balance or out of round.	Balance front wheels or true for out of round.

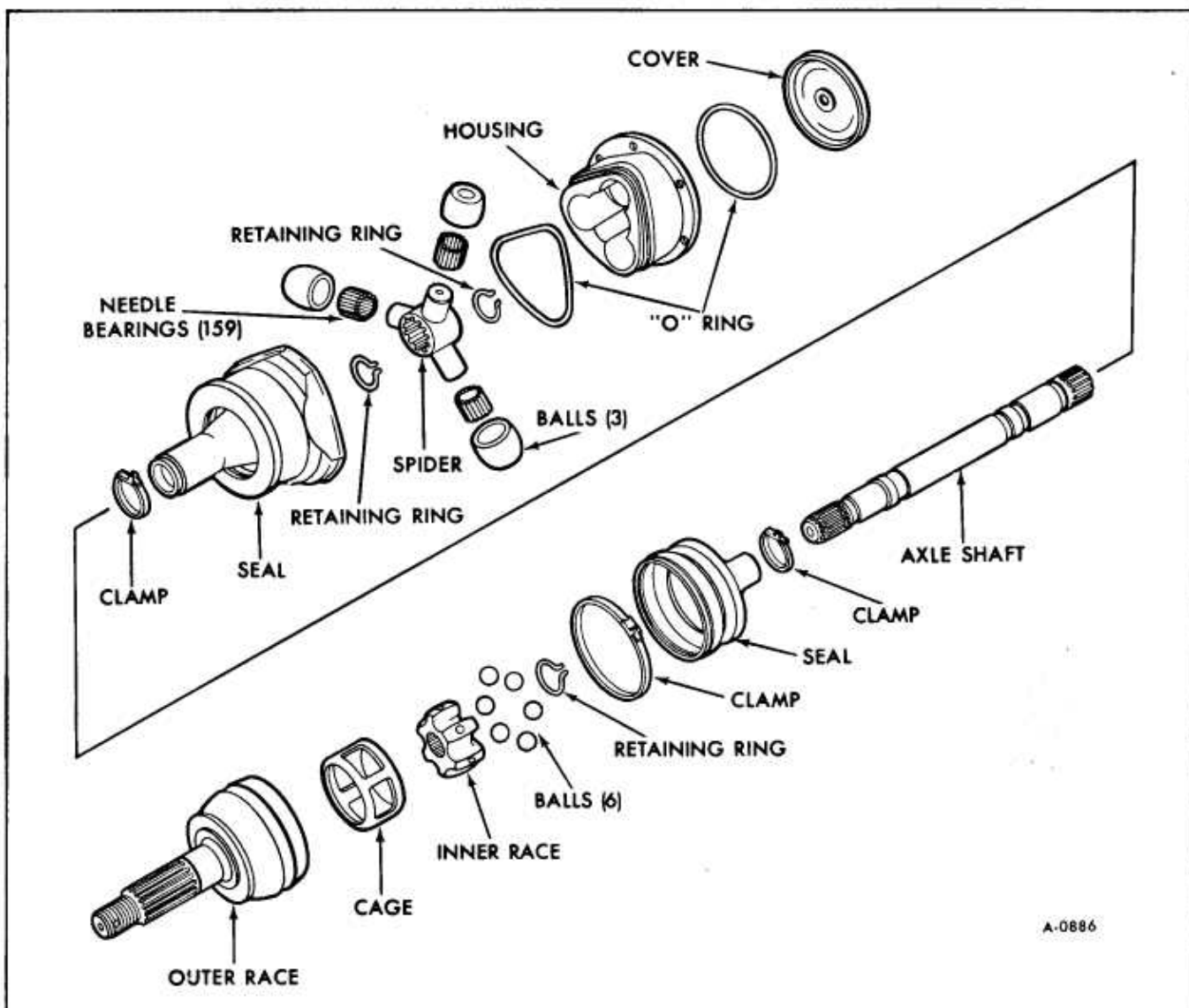

Figure 1-Drive Axle Assembly

## GENERAL DESCRIPTION

Drive axles on the Motor Home are a complete flexible assembly and consist of an axle shaft and an inner and outer constant velocity joint. (figure 1) The inner constant velocity joint has complete flexibility plus inward and outward movement. The outer constant velocity joint has complete flexibility only.

**CAUTION:** Whenever any operations call for disconnecting, connecting, removal or installation of the drive axles, care must be exercised to prevent damage to constant velocity joint seals. Seals may be wrapped with floor mat rubber or old innertube, etc.

*Make sure any rubber protective covers that are used are removed before vehicle is started or driven.*

## DRIVE AXLE ASSEMBLY (RIGHT HAND)

### REMOVAL

1. Hoist Motor Home under lower control arms.
2. Remove drive axle cotter pin, nut and washer. (figure 2)

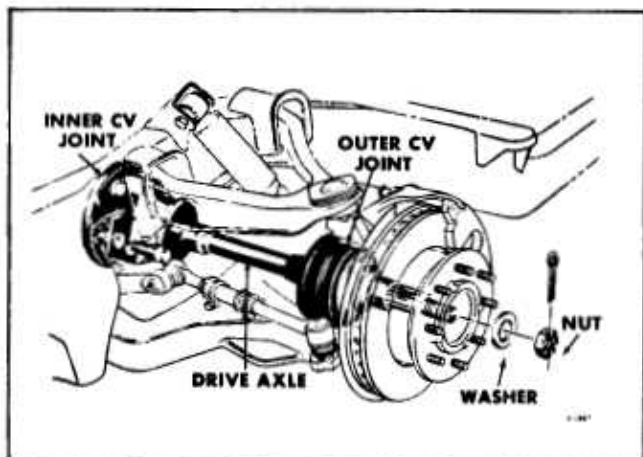

Figure 2—Drive Axle Installed

3. Remove inner C.V. joint attaching bolts. (figure 3)

4. Push inner C.V. joint outward enough to disengage from R.H. final drive output shaft and move rearward.

5. Remove R.H. output shaft support bolts to engine and final drive. (figure 2).

6. Remove R.H. output shaft.

7. Remove drive axle assembly.

**CAUTION:** Care must be exercised so that C.V. joints do not turn to full extremes and that seals are not damaged against shock absorber or stabilizer bar.

## INSTALLATION

See CAUTION on Page 3B-1 of this section.

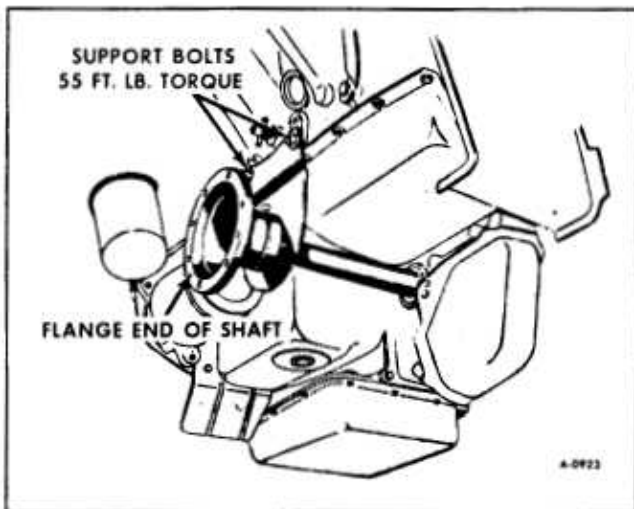

Figure 3—Aligning R.H. Output Shaft

1. Carefully place R.H. drive axle assembly into lower control arm and enter outer race splines into knuckle.

2. Lubricate final drive output shaft seal with Special Seal Lubricant, No. 1050169 or equivalent.

3. Install R.H. output shaft into final drive and attach support bolts to engine.

**IMPORTANT:** When attaching the right hand output shaft to the engine bracket, do not let the shaft hang. Referring to Figure 3, assemble bracket bolts loosely, and by moving the flange end of the shaft up and down, and back and forth, find the center location. Hold the shaft in this position and then torque the bolts to 55 ft. lbs. on support.

4. Move R.H. drive axle assembly toward front of car and align with R.H. output shaft. Install NEW attaching bolts and torque to 65 ft. lbs.

5. Install washer and nut on drive axle. Torque to 110 ft. lbs. Insert cotter pin and crimp. Tighten nut to insert cotter pin.

6. Lower hoist.

## DRIVE AXLE ASSEMBLY (LEFT HAND)

### REMOVAL

1. Hoist Motor Home under lower control arms.

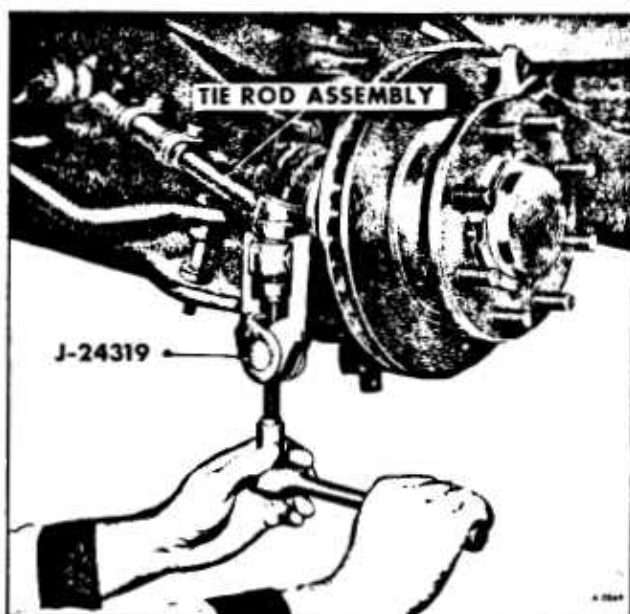

Figure 4—Removing Tie-Rod End

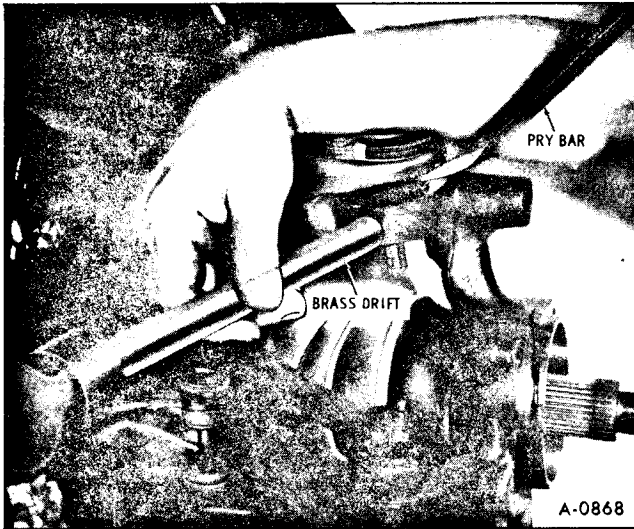

Figure 5—Removing Upper Ball Joint

2. Remove wheel.
3. Remove drive axle cotter pin, nut and washer.
4. Remove tie rod end cotter pin and nut.
5. Using Tool J-24319 as shown in Figure 4, remove tie rod end from spindle.
6. Remove bolts from drive axle assembly to left output shaft.
7. Remove upper control arm ball joint cotter pin and nut. Remove brake hose clip from ball joint stud.
8. Using hammer and brass drift, drive on knuckle until upper ball joint stud is free. (figure 5)
9. Using Tool J-24319 (figure 6) remove lower ball joint from knuckle. Care must be exercised so that ball joint doesn't damage drive axle seal.
10. Remove knuckle. Support knuckle so that brake hose is not damaged.
11. Carefully guide drive axle assembly outboard.

**CAUTION:** Care must be exercised so that C.V. joints do not turn to full extremes and that seals are not damaged against shock absorber or stabilizer bar.

## INSTALLATION

See CAUTION on Page 1 of this section.

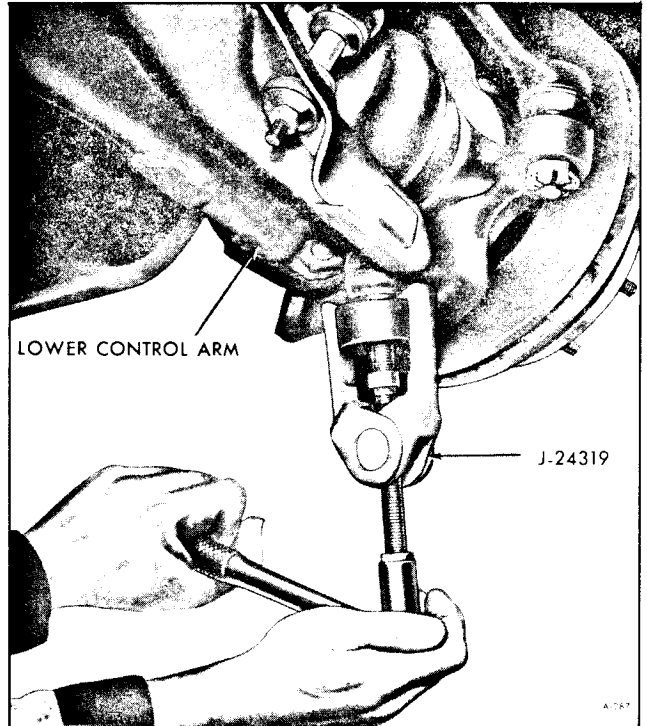

Figure 6—Removing Lower Ball Joint

1. Carefully guide L.H. Drive axle assembly onto lower control arm.
2. Insert lower control ball joint stud into knuckle and attach nut. Do not torque.
3. Center L.H. drive axle assembly in opening of knuckle and insert upper ball joint stud.
4. Place brake hose clip over upper ball joint stud and install nut. Do not torque.
5. Insert tie rod end stud into knuckle and attach nut. Torque to 40 ft. lbs. Install cotter pin and crimp. Tighten nut to install cotter pin.
6. Align inner C.V. joint with output shaft and install NEW attaching bolts. Torque to 65 ft. lbs.
7. Torque upper and lower ball joint stud nuts to 50 ft. lbs. (upper); 100 ft. lbs. (lower). Tighten nut to install cotter pins.

**CAUTION:** Upper ball joint cotter pin must be crimped toward upper control arm to prevent interference with outer C.V. joint seal.

8. Install drive axle washer and nut. Torque to 110 ft. lbs. Install cotter pin and crimp. Tighten nut, if necessary to install cotter pin.

9. Install wheel.
10. Remove floor stands and lower hoist.

## CONSTANT VELOCITY JOINT (C.V. JOINT OUT OF VEHICLE)

The C.V. joints are to be replaced as a unit and are only disassembled for repacking and replacement of damaged seals.

### DISASSEMBLY (OUTER C.V. JOINT)

1. Refer to "DRIVE AXLE ASSEMBLY (LEFT HAND) OR (RIGHT HAND)."

2. Insert axle assembly in vise. Clamp on mid-portion of axle shaft.

**NOTE:** Protect against jaw marks, do not over-clamp.

3. Remove inner and outer seal clamps. (figure 7)

4. Slide seal down axle shaft to gain access to C.V. joint.

**NOTE:** Seal may need to be rolled back or cut away on R.H. drive axle.

5. Using Tool J-5586, spread retaining ring until C.V. joint can be removed from axle spline. (figure 8)

6. Remove retaining ring (figure 15).

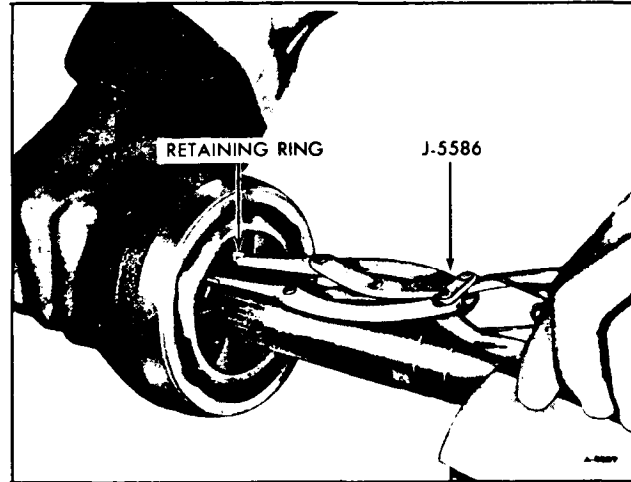

Figure 8—Removing Retaining Ring

7. Slide seal from axle shaft and discard.

8. Remove excess grease from C.V. joint.

9. Insert C.V. joint in vise, clamping on shank.

**NOTE:** Use jaw blocks to prevent damage to the joint shank.

10. Carefully place a brass drift against one of the lobes of the inner race and tap gently as shown in Figure 9. Tip the race far enough to remove the first ball. The rest of the balls should be removed one at a time, with the cage tipped as shown in Figure 10. It may be necessary to carefully pry the last ball out of the cage with a screwdriver.

11. Turn cage 90° and with slot in cage aligned with land in outer race lift out inner race and cage. (figure 11)

12. While holding cage and inner race, turn inner race 90°. Line up short land of inner race with slot

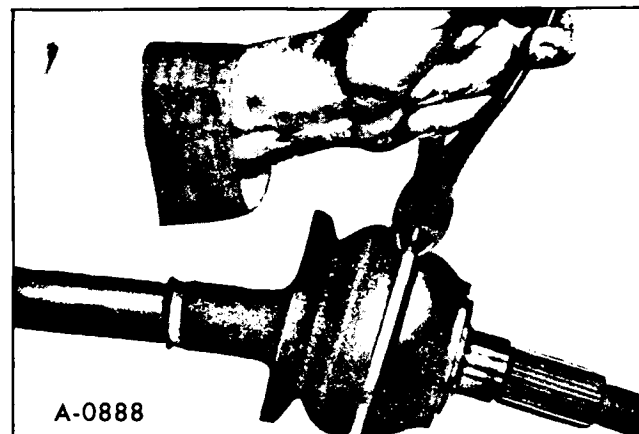

Figure 7—Cutting Seal Clamp

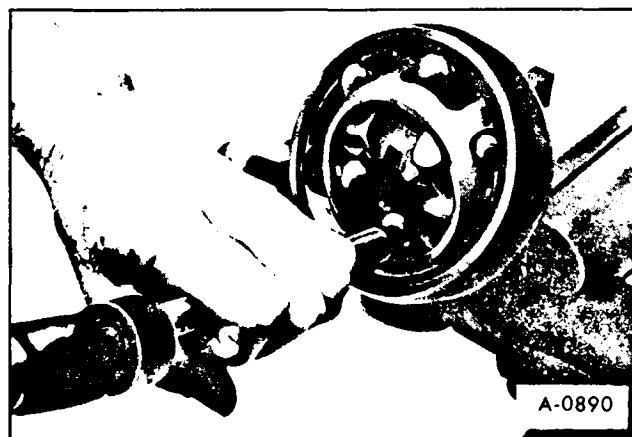

Figure 9—Tapping on Inner Race

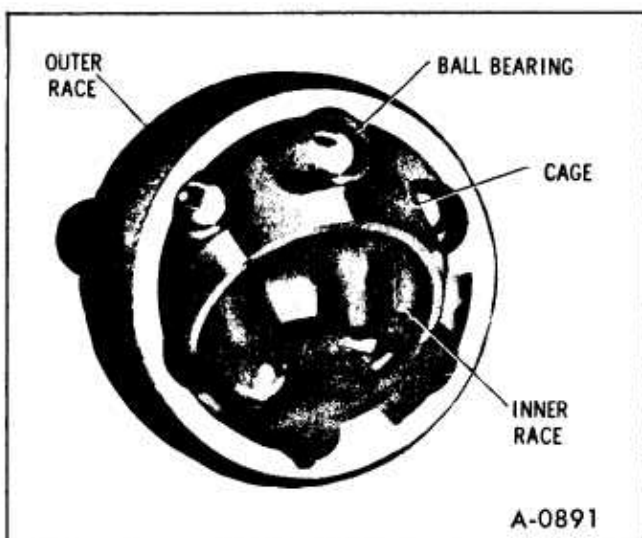

Figure 10—Removing Ball Bearings

in cage. Move short land through cage and turn inner race up and out of cage. (figure 12)

## CLEANING AND INSPECTION (OUTER)

Wash all metallic parts thoroughly in a cleaning solvent. Dry with compressed air. Rubber seal must be replaced whenever C.V. joint is disassembled for service.

**NOTE:** Outer and inner race may show a definite polished area where the balls travel. The C.V. joint should not be replaced for this reason. However, if this wear pattern is suspected to be the cause of a noisy or vibrating C.V. joint, the joint should be replaced.

1. Inspect outer race for excessive wear or scoring in the ball grooves. Inspect shaft splines and threads for any damage.

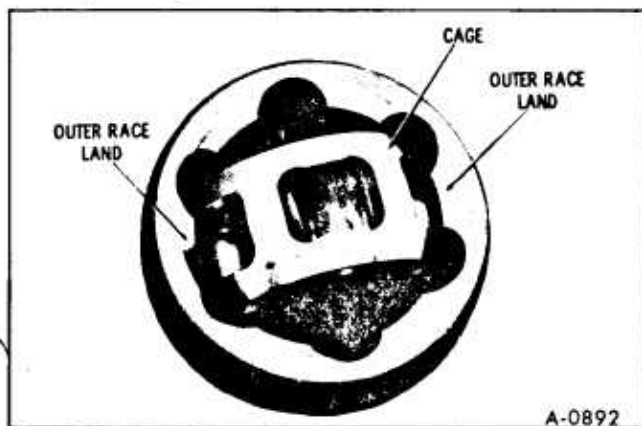

Figure 11—Positioning Cage

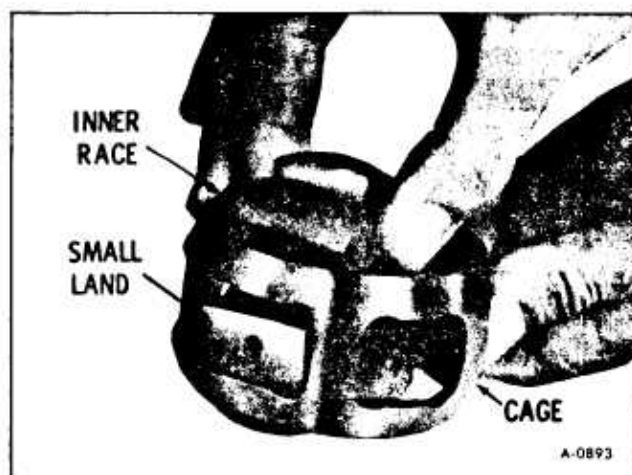

Figure 12—Removing or Installing Inner Race from Cage

2. Inspect balls (six) for nicks, cracks, breaks or scores.

**NOTE:** Slight scuffing or nicking is considered normal.

3. Inspect cage for cracks, breaks or excessive brinelling of the window flats. Some wear and slight brinelling from ball contact is normal.

4. Inspect inner race for excessive wear, scores or breaks.

5. Inspect retaining ring for being broken.

**NOTE:** If any of the above defects, except Item 5 are found, the C.V. joint assembly will have to be replaced as a unit. Retaining ring may be replaced separately.

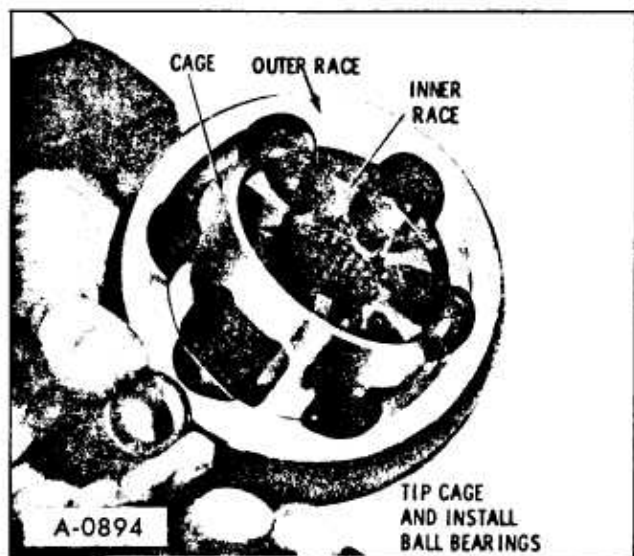

Figure 13—Installing Balls in Outer Race



## ASSEMBLY

1. Insert short land of inner race through bore of cage and pivot to install in cage. (figure 12)

2. Insert outer race in vise, clamping on shank. Protect shank from damage. Do not tighten too tight.

3. Insert cage and inner race into outer race by aligning windows on cage with lands on outer race. (figure 11) Pivot cage and inner race 90°, being certain that step on cage bore is positioned to inside of joint and snap ring groove in inner race is facing outside. (figure 13)

4. Insert balls into outer race one at a time by rocking assembly to each subsequent ball groove until all six balls are installed. (figure 13)

**NOTE:** If a brass drift is used to install the sixth ball, make certain metallic chips from drift do not enter assembly.

5. Pack C.V. joint full of Lubricant No. 1050802 or equivalent.

6. Pack inside of seal with Lubricant No. 1050802 or equivalent until folds of seal are full.

7. Place service clamp on axle shaft. Two wraps of band are required.

8. Install seal onto axle shaft.

9. Install retaining ring into inner race with tangs protruding into relieved area. (figure 16)

10. Insert axle shaft into splines of outer C.V. joint until retaining ring secures shaft in second snap ring groove.

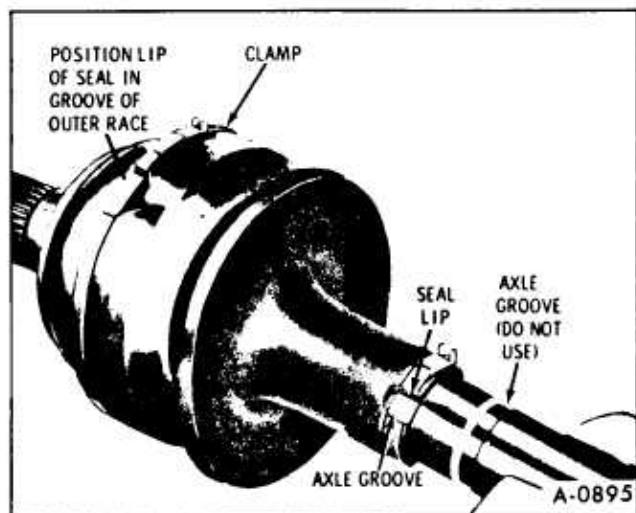

Figure 14—Positioning Seal

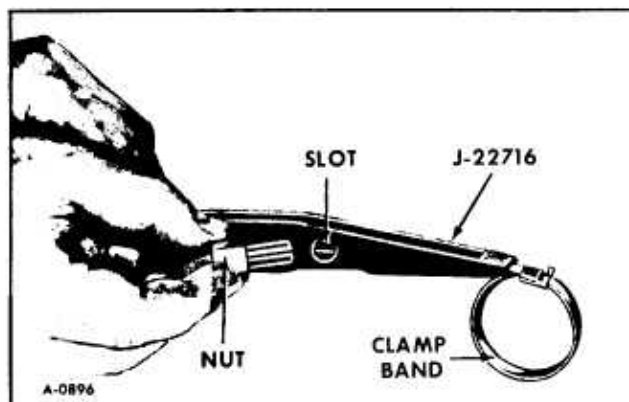

Figure 15—Assembly of J-22716 to Band

11. Position seal in groove of outer race. (figure 14)

12. Position small end of seal in nearest joint groove on axle shaft. (figure 14)

**NOTE:** After seal is in position on axle shaft make sure no lubricant is in grooves of seal before installing seal clamp band.

13. With service clamps over seals in correct position, follow procedures listed below and using Figures 15–19.

a. Pull clamp to desired size and insert band into Tool J-22716. Then insert nut into tool with band in slot of nut as shown in Figure 15.

b. Loop seal clamp band around seal end twice with strap passing through its own retainer each time a loop is completed.

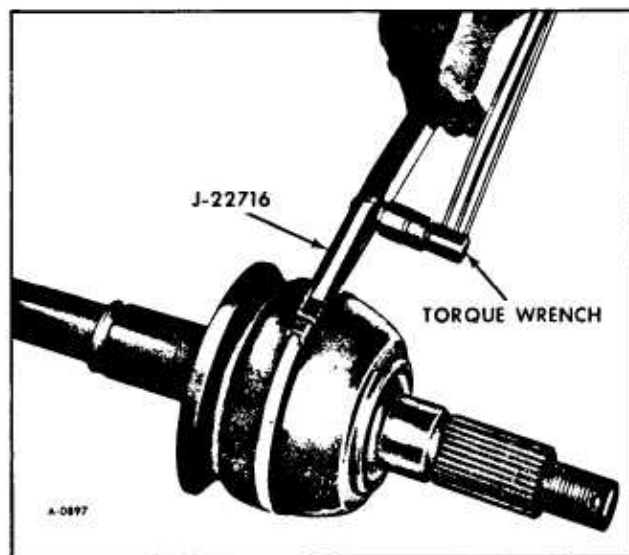

Figure 16—Tightening Band

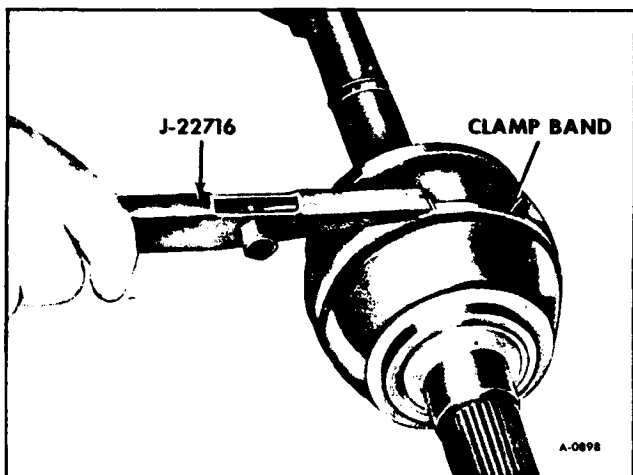

Figure 17—Bending Band Over Lock Tangs

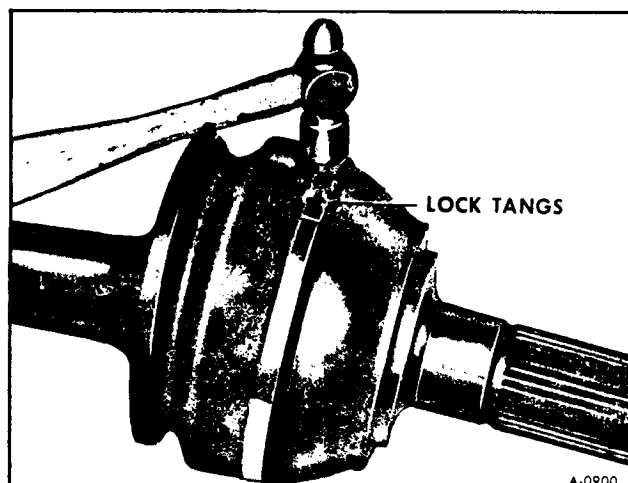

Figure 19—Bending Lock Tangs

c. After completion of second loop, feed extra length of strap into small end of Seal Clamp Band Installer, J-22716.

**NOTE:** Be sure to have the open side of the tool facing up.

d. Slide bolt through holes in side of tool and at the same time, secure strap in slot in the nut.

e. Lift end of strap up and out of the open side of tool.

f. Place a wrench on nut and draw band up tight, then torque nut to 65 in. lbs. (see figure 16) After desired torque is obtained, turn tool over to bend band over lock tangs of clamp, do not let band slip back through tool as this will decrease clamping force (refer to figure 17).

g. Back tool off just enough to permit tapping band with a hammer until it lies flat across top of retainer. Unwind the excess strap and cut it off close to retainer as shown in Figure 18. Tap the tabs down until they retain strap. Tap lightly as excessive force will damage seal (see figure 19).

## DISASSEMBLY (INNER C.V. JOINT)

1. With axle assembly on a bench, pry up staked areas on seal retainer and drive seal off housing with hammer and chisel. (Figure 21)

2. Grasp axle assembly with one hand and joint housing with the other and stand both vertically on the bench. Carefully withdraw axle from housing, being certain not to lose the balls and needles from the axle. (Figure 22)

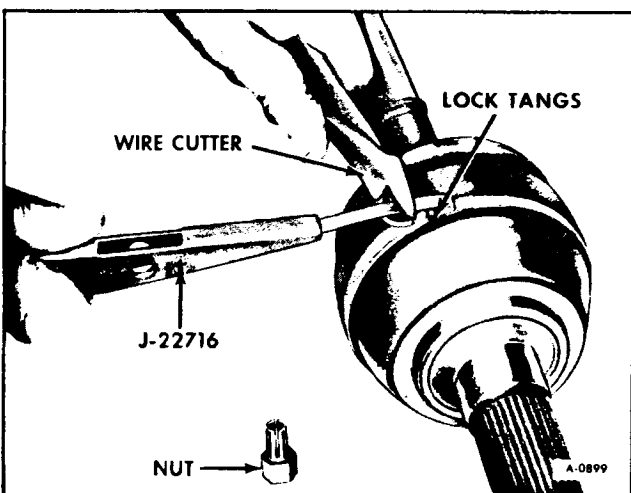

Figure 18—Cutting Off Band

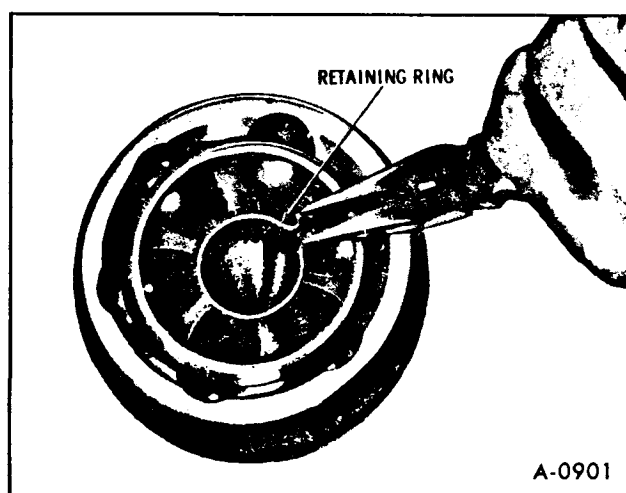

Figure 20—Removing Retaining Ring

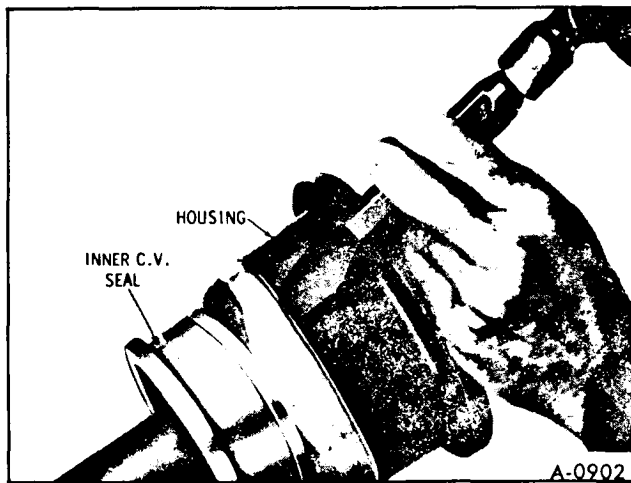

Figure 21—Removing Inner C.V. Joint Seal

**NOTE:** Place a rubber band over ends of spider to retain the three balls and needle bearings. Wipe all excess grease from C.V. parts joint. Remove housing “O” ring seal and discard. Set housing aside.

3. Insert axle assembly in vise. Clamp on mid-portion of axle shaft. Protect against jaw marks.

4. Using Tool J-5586, remove retaining ring from end of axle shaft.

5. Slide spider assembly from axle shaft. (figure 23)

6. Remove retaining ring (inner) from axle shaft using Tool J-5586. (figure 24)

7. Remove small seal clamp.

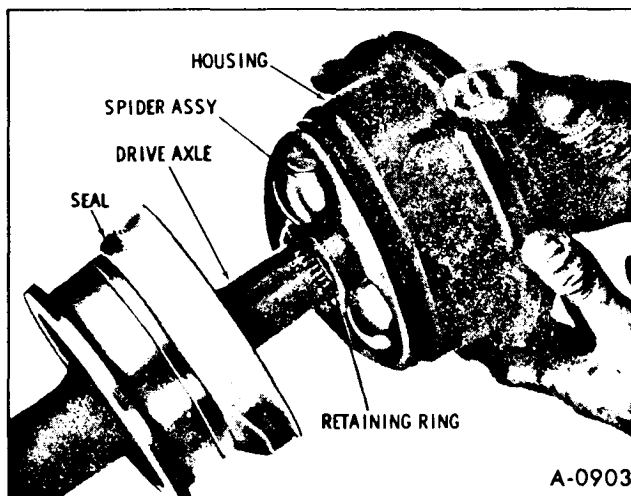

Figure 22—Removing Housing Assembly

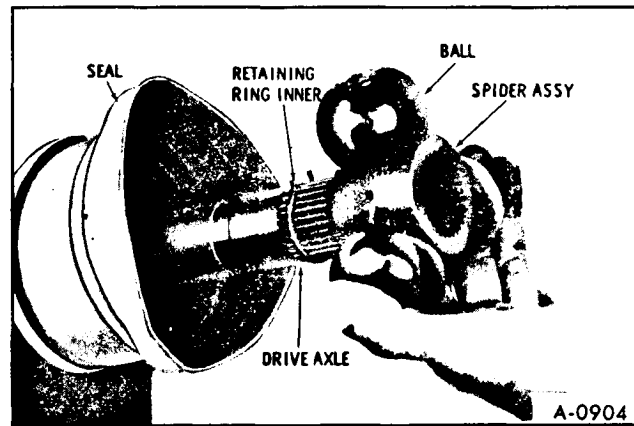

Figure 23—Removing Spider Assembly

8. Slide boot seal off axle shaft and discard seal.

**NOTE:** If there is no leakage or apparent damage to rear cup, it is not necessary to remove it from housing.

9. If necessary to remove cover, proceed as shown in Figure 25 and discard cover.

10. Remove “O” ring from housing and discard.

11. Remove balls (three) from spider, (figure 26) being careful not to lose any of the 53 needle bearings in each of the balls. (figure 27)

## CLEANING AND INSPECTION

Wash all metallic parts thoroughly in a cleaning solvent. Dry with compressed air.

Rubber boot seal, “O” rings and clamp should be

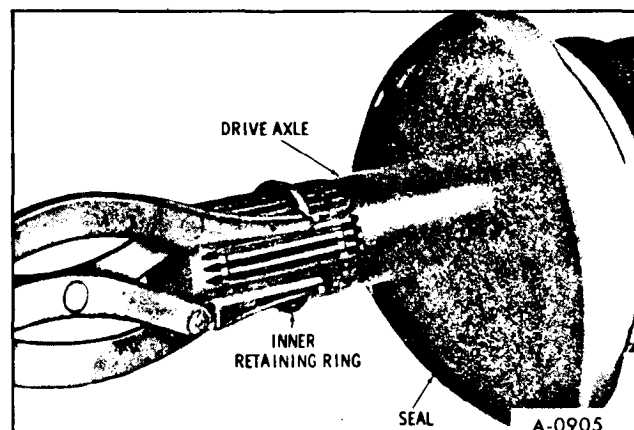

Figure 24—Removing Inner Retaining Ring

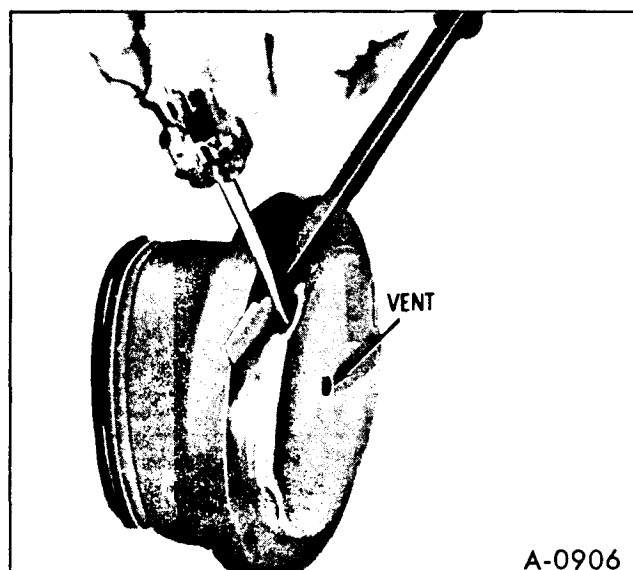

Figure 25—Removing Cover from Housing

replaced whenever C.V. joint is disassembled for service.

**NOTE:** Housing may show a definite polished area where the balls travel but C.V. joint need not be replaced. However, if this wear pattern is suspected to be the cause of a noisy or vibrating C.V. joint, then the housing should be replaced.

1. Inspect housing for excessive wear, brinelling, cracks or chips in housing bore.
2. Inspect retaining rings for cracks or bends.
3. Inspect balls (three) for excessive wear, cracks, nicks, scores or breaks.

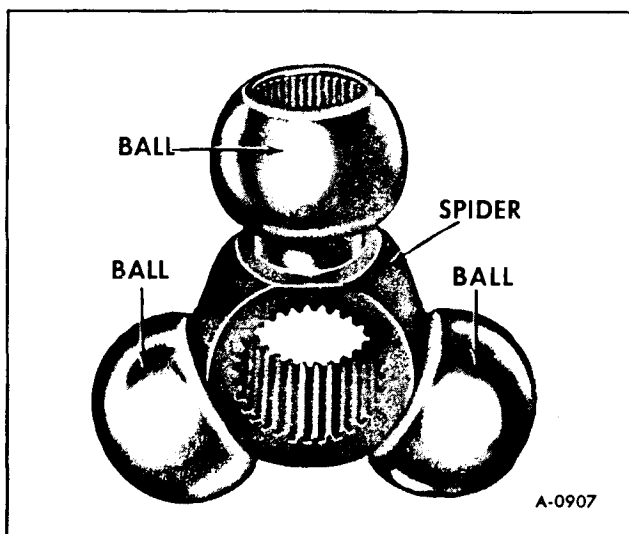

Figure 26—Spider Assembly

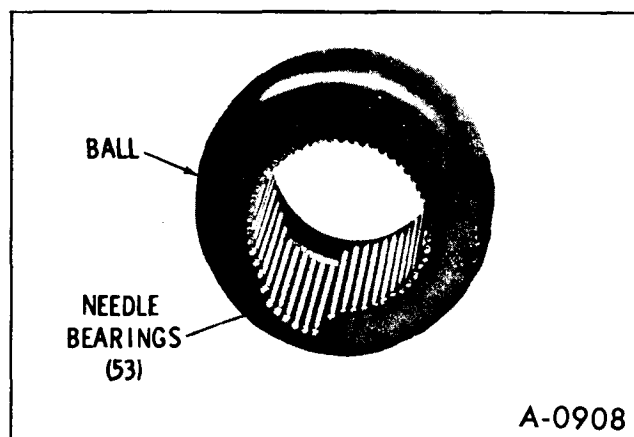

Figure 27—Spider Ball Needle Bearings

4. Inspect needle bearings for wear breaks or bends.
5. Inspect spider for excessive wear, chips or cracks.

## ASSEMBLY

1. Slide new clamp on axle shaft, to be used after seal positioning.
2. Slide seal onto axle shaft.
3. Position retaining ring on axle shaft in the inner groove. (figure 28)
4. Using Lubricant, No. 1050802, or equivalent load balls (three) with the needle bearings (53 to each ball). (figure 23)
5. Carefully install balls on each of the spider journals. (figure 26)

**NOTE:** A rubber band may be used to retain balls in position until spider assembly is installed in housing.

6. Position spider assembly on axle shaft and retain with retaining ring.

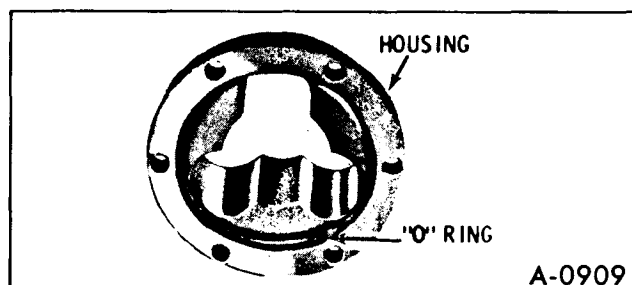

Figure 28—Installing "O" Ring in Housing

7. If rear cover was removed, install new "O" ring in housing and lubricate "O" ring with 1050802 lubricant or equivalent. (figure 28)

8. Install cover into housing using existing A/C Tool No. J-9397-2. Attach two machine bolts (1/4" x 2-1/4" Lg.) as shown in Figure 29 and tighten bolts alternately while tapping lightly with hammer until cover bottoms.

**NOTE:** Be careful that seal is positioned correctly so that "O" ring is not cut.

9. Install new "O" ring in outer groove in housing. (figure 30)

10. Pack housing approximately one-half full with lubricant 1050802 or equivalent.

11. Remove rubber band, if used, from spider assembly.

12. Position spider assembly in line with housing assembly and push into housing until bottomed. (figure 22)

13. Fill housing with lubricant 1050802 or equivalent.

14. Lubricate inside of boot seal retainer and housing outer groove "O" ring with 1050802 lubricant or equivalent.

**NOTE:** Be careful that seal retainer is positioned so that "O" ring is not cut.

15. With housing positioned as shown in Figure 31 tap seal retainer on three lobes alternately with plastic hammer as shown until firmly bottomed, then stake three places into staking groove.

16. Extend inboard joint to maximum length and

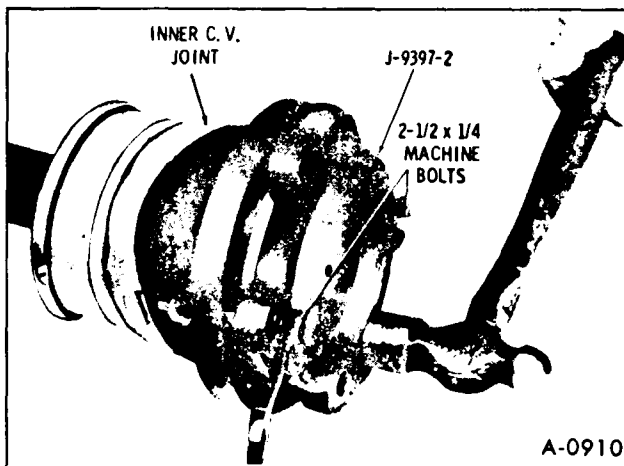

Figure 29—Installing Cover Into Housing

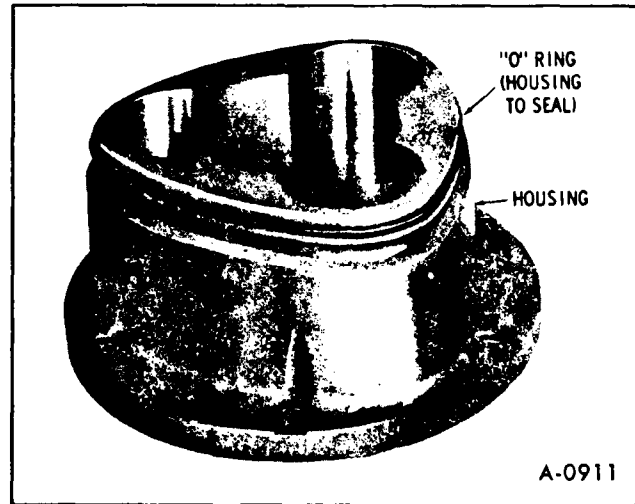

Figure 30—Installing "O" Ring on Housing  
position seal into furthest groove from joint in axle.

17. Install clamp following procedure outlined in Figures 15, 16, 17, 18, 19, and Outer C.V. Joint-Assembly-Step 13.

## DRIVE AXLE

### DISASSEMBLY

1. Remove drive axle assembly (Refer to DRIVE AXLE ASSEMBLY -R. or L. Removal).

2. Remove outer C.V. joint. Refer to Outer C.V. Joint-Disassembly.

3. Remove inner C.V. joint. Refer to Inner C.V. Joint-Disassembly.

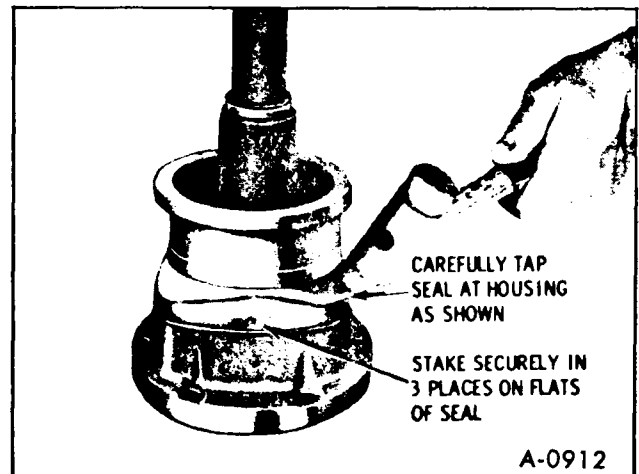

Figure 31—Installing Seal to Housing

**ASSEMBLY**

1. Assemble inner C.V. joint. Refer to Inner C.V. Joint Assembly.

2. Assemble outer C.V. joint. Refer to Outer C.V. Joint - Assembly.

3. Install drive assembly. (Refer to DRIVE AXLE ASSEMBLY - RIGHT OR LEFT INSTALLATION.)

**TORQUE SPECIFICATIONS**

Application	Ft. Lbs.
R.H. Output Shaft Support to Engine Bolts .....	55
Drive Axle to Output Shaft Bolts .....	65
Drive Axle Nut at Wheel Hub .....	110
Tie Rod End to Knuckle Nut .....	35
Ball Joint Stud Nuts .....	50

Nut must be tightened to insert cotter pin.

**SPECIAL TOOLS**

J-5586  
J-9397  
J-22716

Snap Ring Pliers  
C.V. Joint Cover Installer  
C.V. Joint Boot Clamp Tool

# SECTION 3C

## FINAL DRIVE

---

**CAUTION:** *Final drive axle fasteners are an important attaching part in that they could affect the performance of vital components and systems, and/or could result in major repair expense. They must be replaced with one of the same part number or with an equivalent part if replacement becomes necessary. Do not use a replacement part of lesser quality or substitute design. Torque values must be used as specified during reassembly to assure proper retention of this part.*

---

Contents of this section are listed below:

SUBJECT	PAGE NO.
Trouble Diagnosis .....	3C-1
General Description.....	3C-2
R.H. Output Shaft Bearing and Seal .....	3C-3
L.H. Output Shaft and Seal .....	3C-6
Transmission Filler Tube .....	3C-7
Final Drive.....	3C-7
Pinion Housing Seals.....	3C-9
Pinion Bearings .....	3C-12
Final Drive Case .....	3C-12
Final Drive Specifications .....	3C-21
Torque Specifications.....	3C-21
Special Tools .....	3C-21

### TROUBLE DIAGNOSIS

Many noises reported as coming from the final drive actually originate from other sources such as tires, road surfaces, engine, transmission, muffler or body drumming. A thorough and careful check should be made to determine the source of the noise before disassembling the final drive. Noise which originates in other places cannot be corrected by adjustment or replacement of parts in the final drive. It should also be remembered that final drive gears, like any other mechanical device, are not absolutely quiet and should be accepted as being commercially quiet unless some abnormal noise is present.

To make a systematic check for final drive noise under standard conditions, observe the following:

1. Select a level tarvia or asphalt road to reduce tire noise and body drumming.
2. Check final drive lubricant to assure correct level, then drive vehicle far enough to thoroughly warm up the lubricant.
3. Note speed at which noise occurs. Then stop Motor Home and with automatic transmission in neutral, run engine slowly up and down through engine speeds, corresponding to vehicle speed at

which noise was most pronounced, to determine if it is caused by exhaust muffler roar or other engine conditions.

## AXLE NOISES

### Gear Noise

After the noise has been determined as being in the final drive by following the above appraisal procedure, the type of final drive noise should be determined to aid in making repairs if necessary.

Gear noise (whine) is audible from 20 to 65 mph under four driving conditions.

1. Drive - Acceleration or heavy pull.
2. Road Load - Motor Home driving load or constant speed.
3. Float - Using enough throttle to keep the Motor Home from driving the engine - Motor Home slows down gradually but engine still pulls slightly.

4. Coast - Throttle closed and Motor Home in gear. Gear noise most frequently has periods where noise is more prominent, usually 30 to 40 mph and 50 to 60 mph.

### Bearing Noise

Bad bearings generally produce more of a rough growl or grating sound, rather than the whine typical of gear noise. Bearing noise frequently "WOW-WOWS" at bearing rpm, indicating a defective pinion or differential side bearing.

## GENERAL DESCRIPTION (Figures 1, 2 and 3)

The final drive assembly, mounted and splined directly to the automatic transmission, consists of a pinion drive and ring gear set (with a ratio of 3.07:1), case assembly with two side gears and two pinion gears which are retained to the case with a pinion shaft. A lock pin is used instead of a bolt to lock the

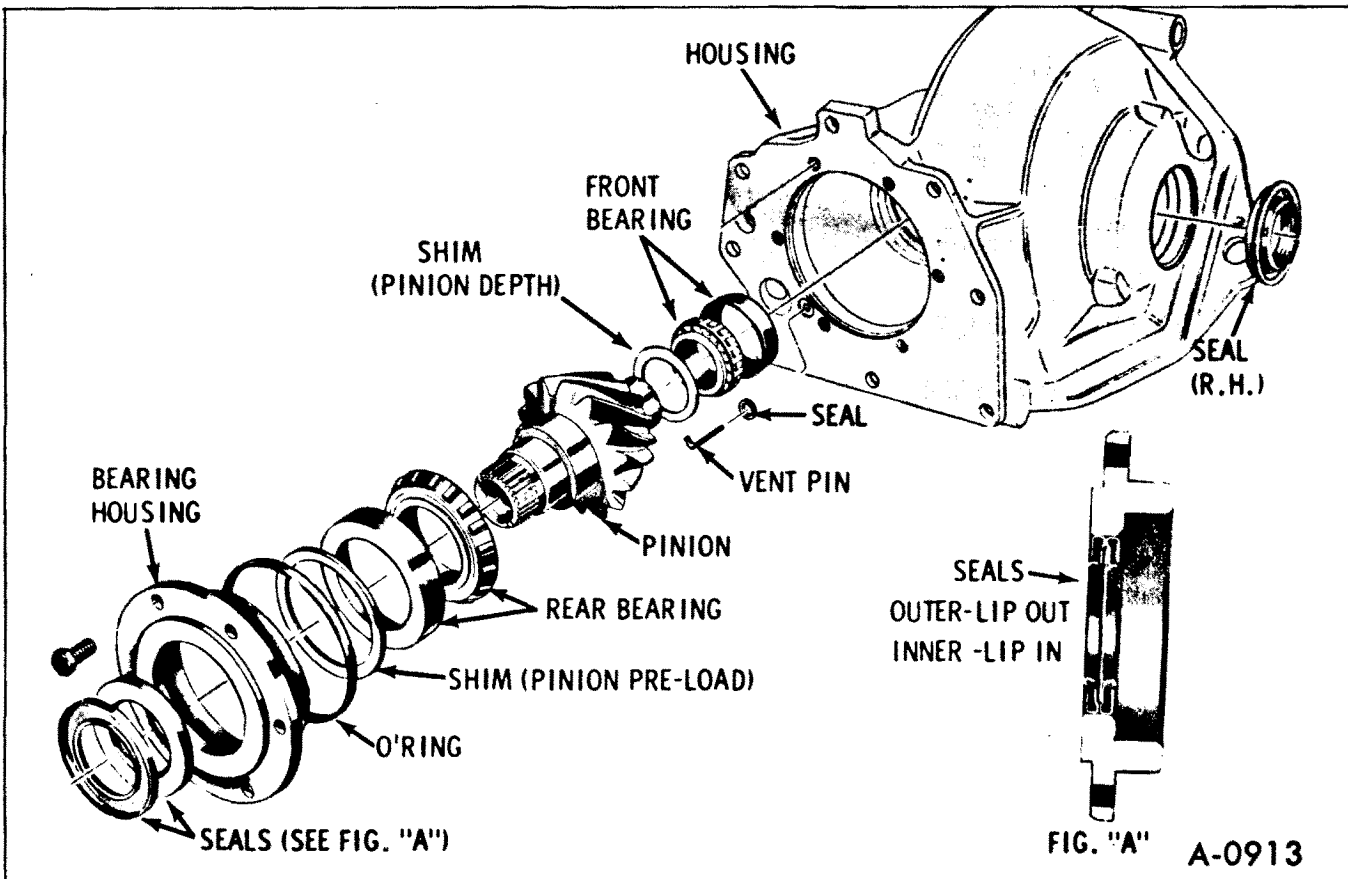

Figure 1-Final Drive Pinion Assembly



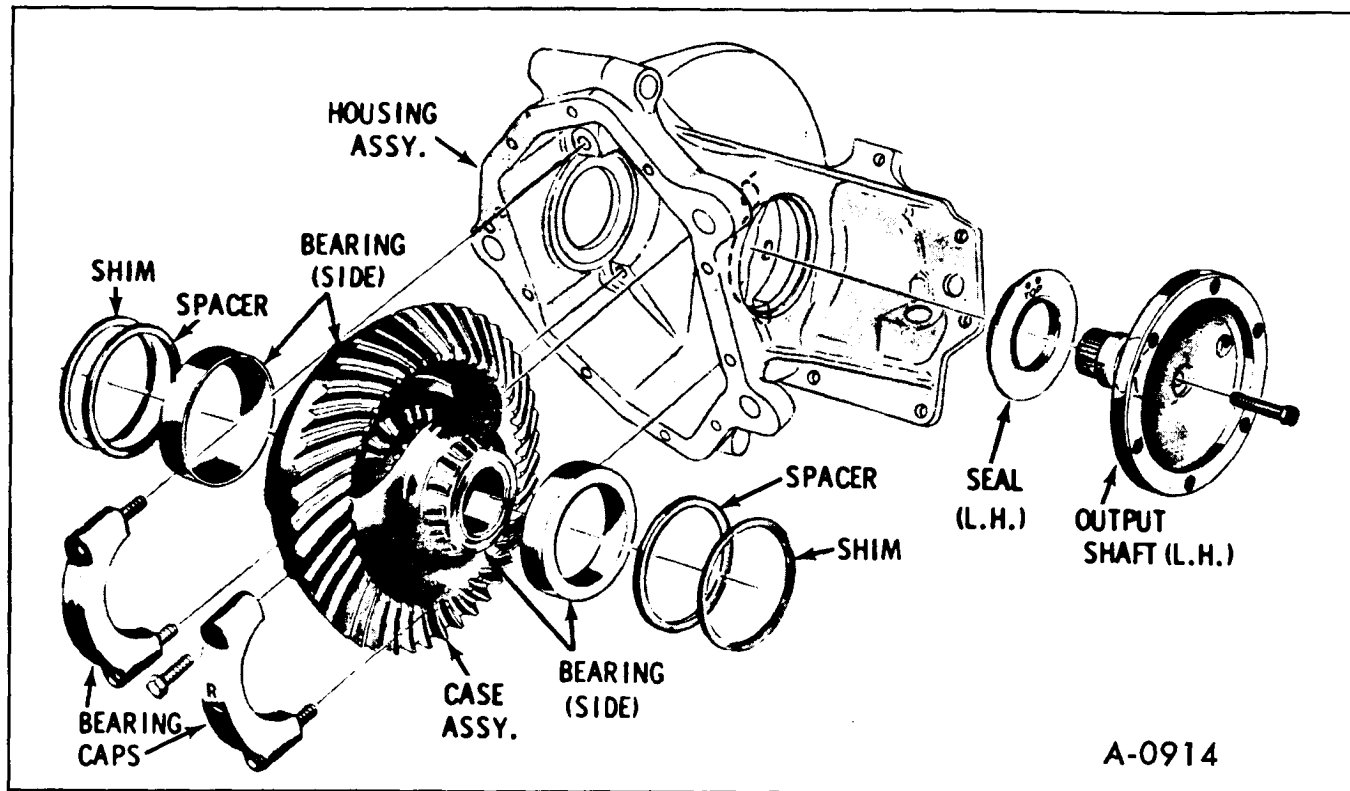

Figure 2-Final Drive Case Assembly

pinion shaft to the case. There are thrust washers used behind the side gears and shims behind the pinion gears the same as the conventional differential. The left side gear is different than the right side in the respect that it has a threaded retainer plate that the left output shaft bolts to. The two side bearings are the same and the pre-load shims are identical for the right and left side.

The left output shaft has the retainer bolt going through the shaft to the side gear. The right output shaft has a vent hole in the flange.

**CAUTION:** When removing or installing the right drive axle, be sure to disconnect the negative battery cables. It is possible to short out the starter motor by making contact between the wrench and the starter motor terminals.

## RH OUTPUT SHAFT, BEARING AND SEAL

### REMOVAL

1. Disconnect battery cables.

2. Hoist Motor Home.

3. Remove attaching bolts, R.H. Drive axle to R.H. output shaft. Then move drive axle rearward until free from output shaft.

4. Disconnect support from engine. (figure 4)

5. Remove output shaft assembly.

6. If output shaft seal is to be replaced, install Seal Remover J-23129 into seal and drive seal out with a hammer. (figure 5)

7. If output shaft bearing is to be replaced, it can be removed with a press as shown in Figure 6.

### INSTALLATION

See CAUTION on Page 3C-1 of this section.

1. If output shaft bearing was removed, assemble parts as shown in Figure 7.

2. Position assembly in a press and install bearing until seated as shown in Figure 8.

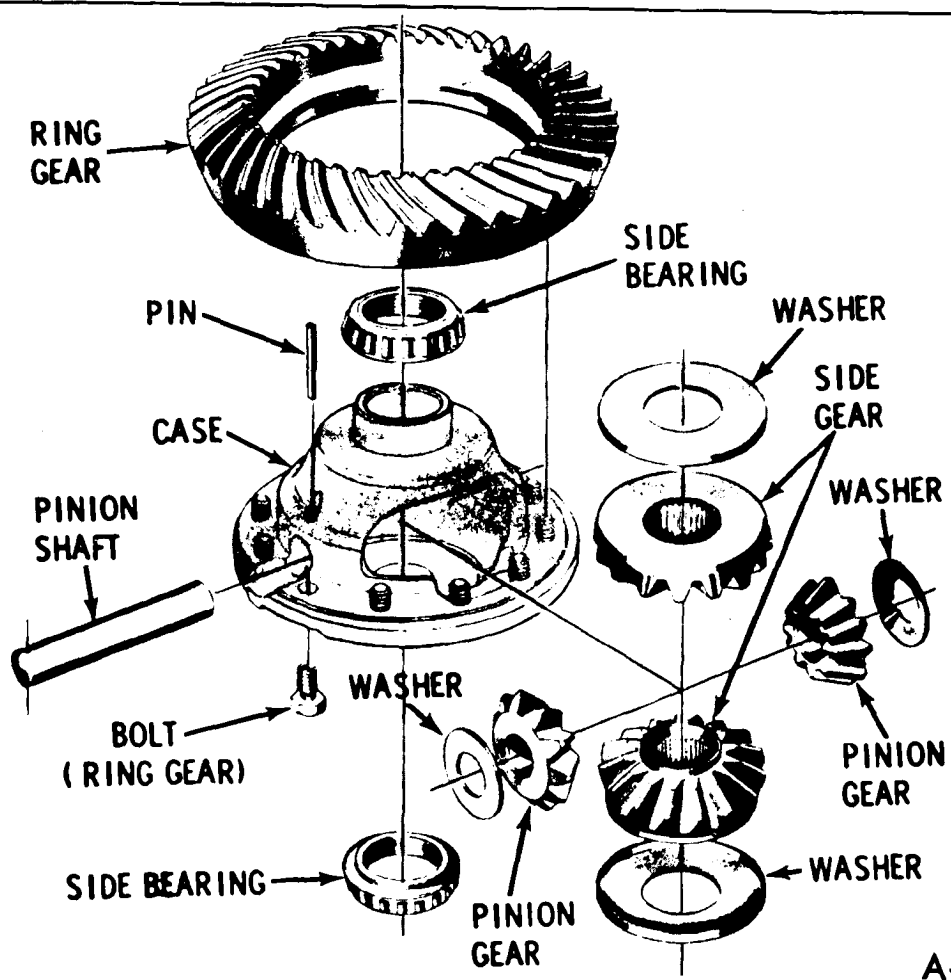

A-0915

Figure 3-Final Drive Case Assembly (Exploded View)

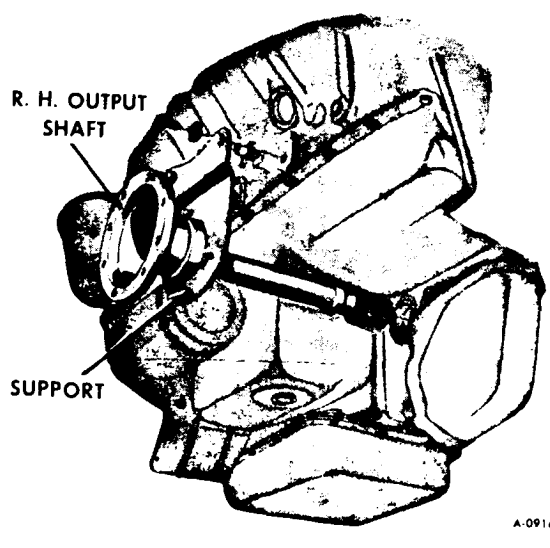

A-0916

Figure 4-R.H. Output Shaft Attachment

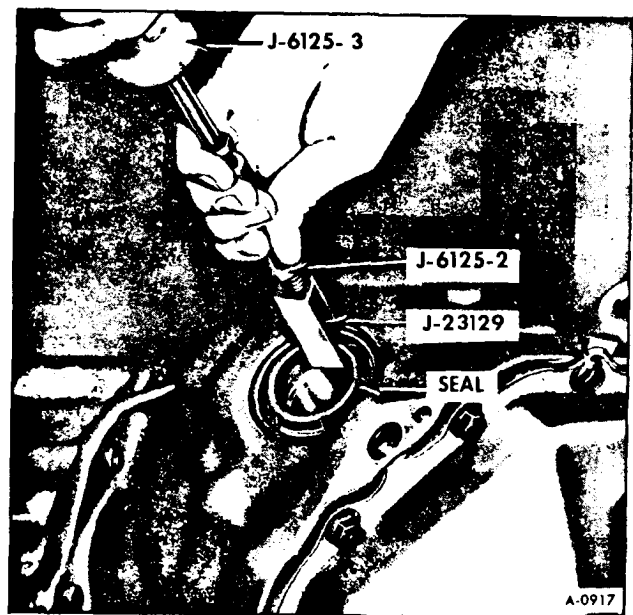

A-0917

Figure 5-Removing R.H. Output Shaft Seal

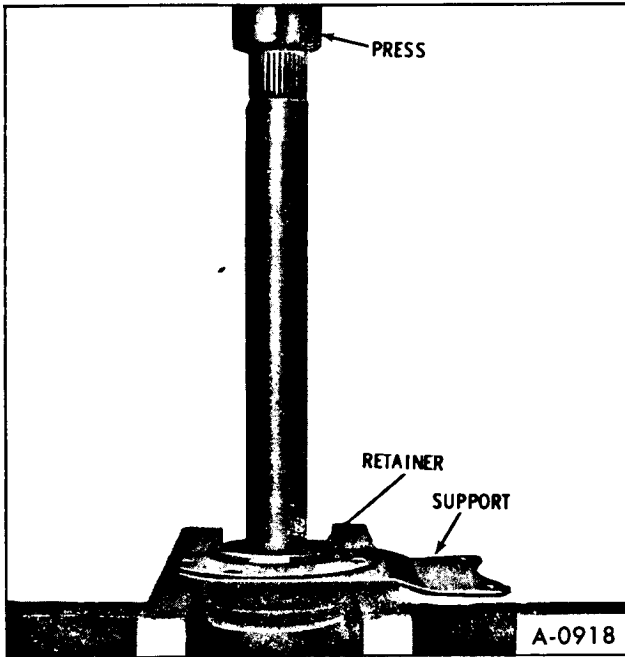

Figure 6—Removing R.H. Output Shaft Bearing

3. Pack area between bearing and retainer with wheel bearing grease, then install slinger as shown in Figure 9.

4. If output shaft seal was removed, new seal can be installed as shown in Figure 10.

5. Apply Special Seal Lubricant No. 1050169 or equivalent to output shaft seal, then install output shaft into final drive indexing splines of output shaft with splines in side gear.

6. Install support to engine and brace. (figure 4)

**NOTE:** When attaching the right hand output

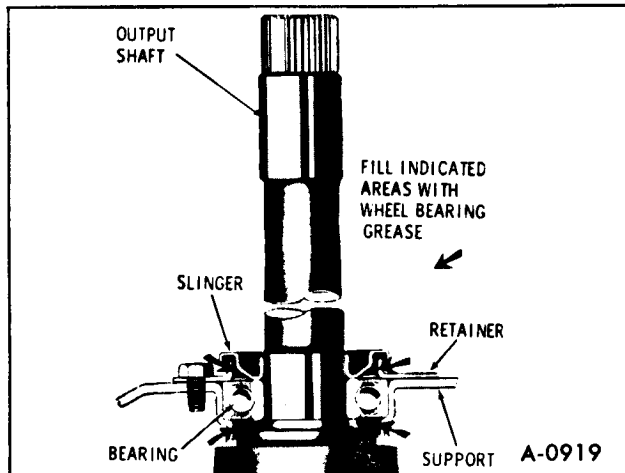

Figure 7—R.H. Output Shaft Assembly

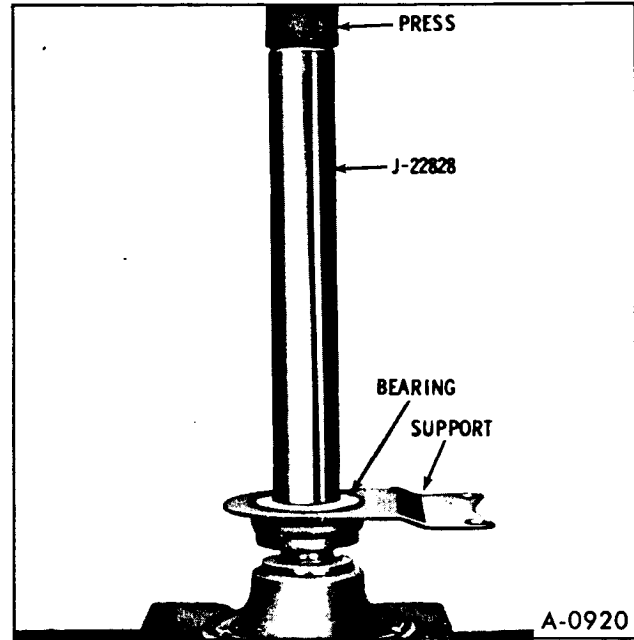

Figure 8—Installing R.H. Output Shaft Bearing

shaft to the engine, do not let the shaft hang. Assemble support bolts loosely, and by moving the flange end of the shaft up and down, and back and forth, find the center location. Hold the shaft in this position and then torque the bolts to 55 ft. lbs. on support. Figure 11.

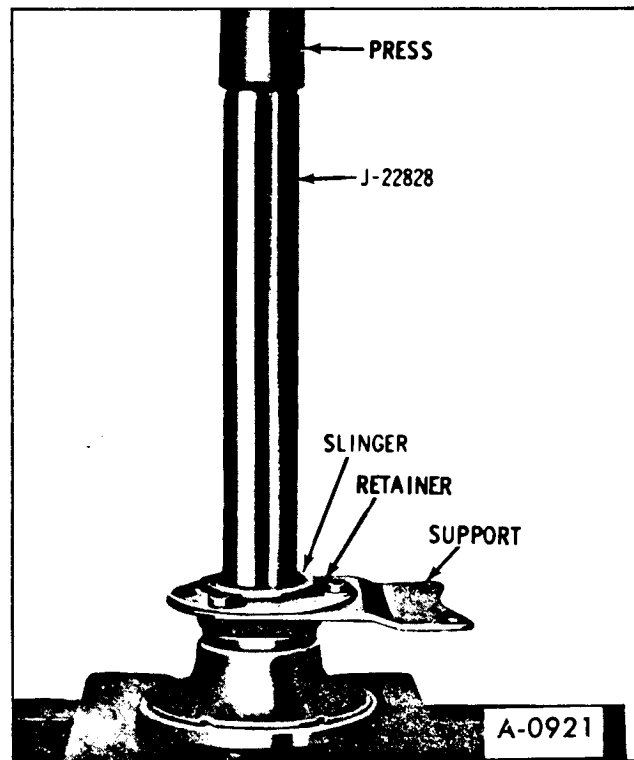

Figure 9—Installing Slinger

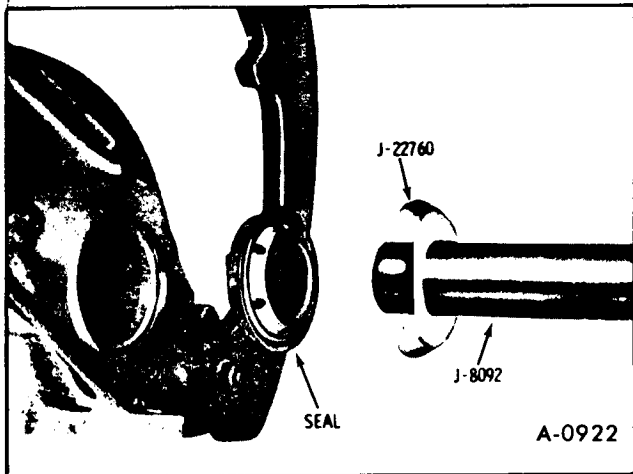

Figure 10—Installing R.H. Output Shaft Seal

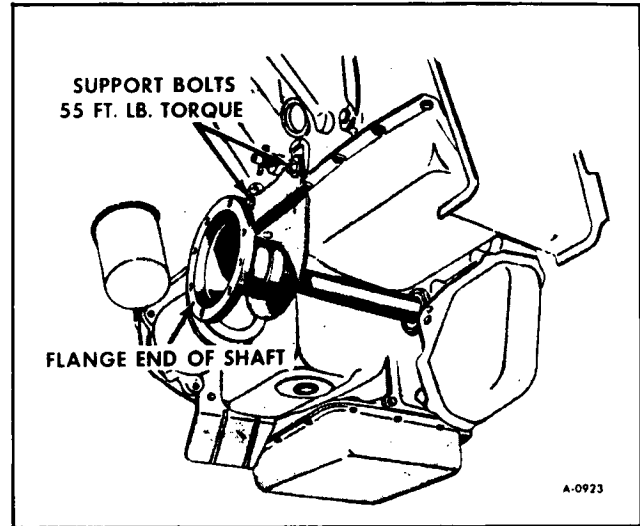

Figure 11—Aligning R.H. Output Shaft

7. Move drive axle forward until alignment with output shaft is obtained. Install NEW attaching bolts. Torque to 65 ft. lbs.

8. Connect battery cables.

9. Check final drive oil level and check for oil leaks.

## LH OUTPUT SHAFT AND SEAL

### REMOVAL

1. Remove L.H. Drive axle. Refer to Section 3B "DRIVE AXLE ASSEMBLY (LEFT HAND)", Steps 1 through 12 under "REMOVAL."

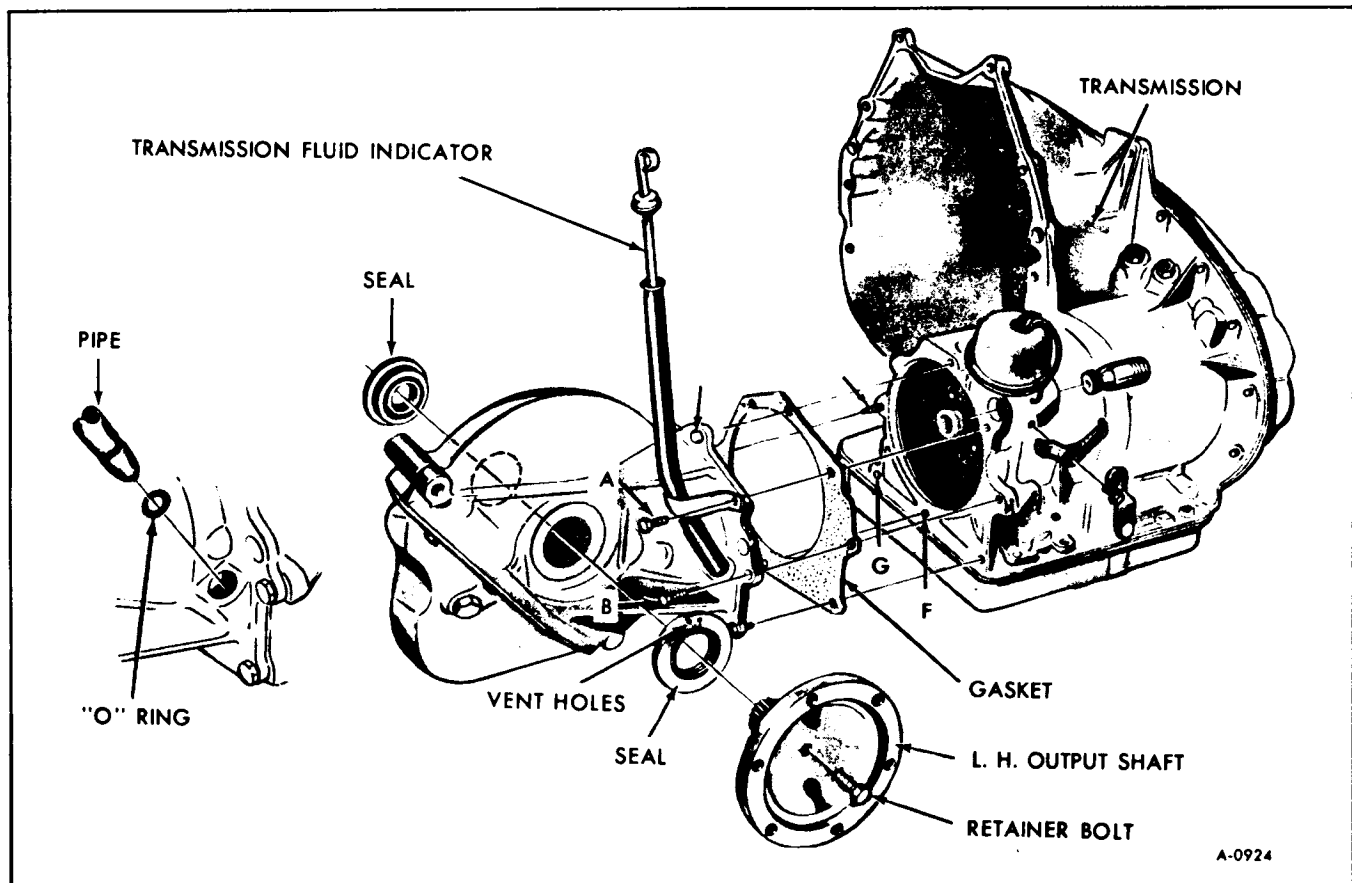

Figure 12—Final Drive Attachment

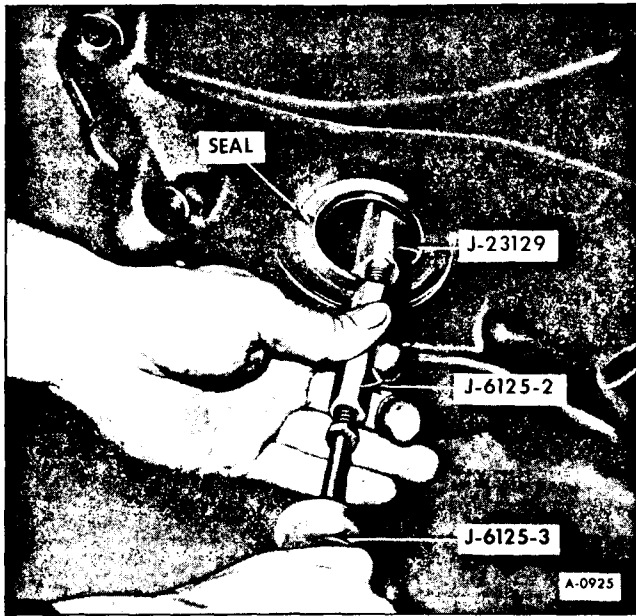

Figure 13—Removing L.H. Output Shaft Seal

2. Using a 9/16" socket remove L.H. output shaft retaining bolt and remove L.H. output shaft. (figure 12)

If output shaft seal is to be replaced, insert Tool J-23129 into seal and drive out with a hammer. (figure 13)

## INSTALLATION

See CAUTION on Page 3C-1 of this section.

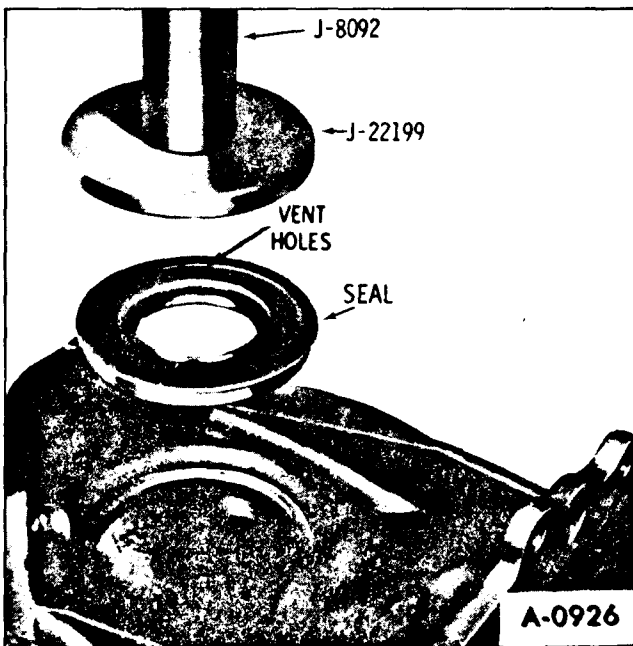

Figure 14—Installing L.H. Output Shaft Seal

1. If output shaft seal was removed, install new seal as shown in Figure 14.

**NOTE:** Left output shaft seal is installed with vent hole toward top of final drive housing in the in-vehicle position.

2. Apply Special Seal Lubricant No. 1050169 or equivalent to the seal; then, insert output shaft into final drive assembly, indexing splines of output shaft with splines in side gear.

3. Install L.H. output shaft retaining bolt and torque to 40 ft. lbs. (figure 12)

4. Install L.H. drive axle. Refer to Section 3B, DRIVE AXLE ASSEMBLY (LEFT HAND), Steps 1 through 10 under INSTALLATION.

## TRANSMISSION FILLER TUBE REMOVAL AND INSTALLATION

The automatic transmission filler tube is located on the final drive. The filler tube can be removed by removing bolt "A", Figure 12 and then pulling the filler tube out of the housing. To install, position a new "O" ring seal on the filler tube. Coat seal with Special Seal Lubricant No. 1050169 or equivalent and install filler tube into housing. Install bolt "A" and torque to 25 ft. lbs.

## FINAL DRIVE

### REMOVAL

1. Disconnect battery cables.
2. Hoist Motor Home.
3. Remove bolts "A", "B", and "C". (Figure 12)
4. Disconnect right and left drive axles from the output shafts.
5. Move R.H. Drive axle rearward until R.H. output shaft is clear to be removed from final drive.
6. Disconnect R.H. output shaft support from engine (figure 4) and remove from final drive.
7. Remove bolt "X" and "Y" and loosen "Z". (figure 15)
8. Remove final drive cover and allow lubricant to drain.

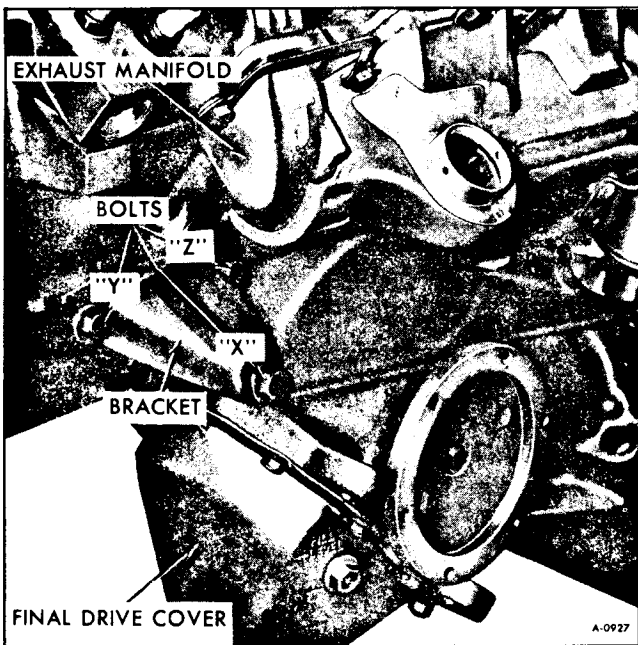

Figure 15—Disconnecting Final Drive From Engine

9. Position transmission jack with adapter for final drive as shown in Figure 16. Install an anchor bolt through final drive housing and lift pad.

**NOTE:** Adapters for removing final drive assemblies are available from most transmission jack manufacturers.

10. Remove bolts "E", "F" and "G" and nut "H" (figure 12).

11. Move transmission lift toward front of Motor Home to disengage final drive splines from transmission.

**NOTE:** As the final drive is disengaged from

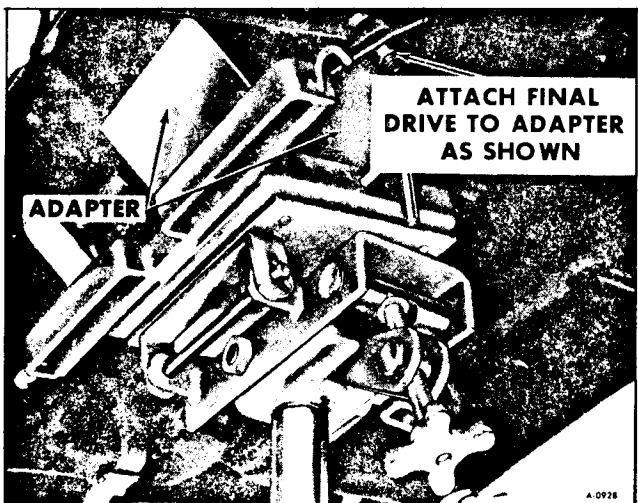

Figure 16—Connecting Lift to Final Drive

transmission, some transmission fluid will be lost. Provide a container to prevent oil from running on floor.

12. Pivot final drive support bracket upward for clearance.

13. Lower transmission lift and remove final drive from lift.

14. Using a 9/16" socket remove the left output shaft retainer bolt, then pull output shaft from final drive. (figure 12)

15. Remove transmission to final drive gasket.

## INSTALLATION

See CAUTION on Page 3C-1 of this section.

1. Apply Special Seal Lubricant No. 1050169 or equivalent to both output shaft seals.

2. Install the left output shaft into the final drive. Retain with bolt. Torque bolt to 40 ft. lbs. (figure 12)

3. Position final drive on transmission lift and install an anchor bolt through housing and lift pad. (figure 16)

4. Apply a thin film of Special Seal Lubricant No. 1050169 or equivalent on the transmission side of a new final drive to transmission gasket, then position gasket on transmission.

5. Raise transmission lift. Align the bolt stud "H" on the transmission with the mating hole in the final drive. Move final drive until it mates with the transmission. (Figure 12)

**NOTE:** It may be necessary to rotate the left output shaft so that the splines of the final drive pinion engage the splines of the transmission output shaft. Do not allow gasket to become mispositioned while engaging splines.

6. Install bolts "E", "F" and "G" and nut "H" (figure 12). Install bolts "A", "B" and "C". (figure 12) Torque all final drive to transmission bolts to 25 ft. lbs. Torque nut to an approximate 25 ft. lbs.

7. Install bolt "X" and torque to 105 ft. lbs. Tighten and torque bolts "Y" and "Z" to 50 ft. lbs. (figure 15)

8. Loosen and remove lift from final drive.

9. Position a new cover gasket on the final drive, then install cover. Torque cover bolts to 25 ft. lbs.

10. Install right output shaft into final drive indexing splines of output shaft with splines of side gear. Install support bolts.

**NOTE:** When attaching the right hand output shaft to the engine, do not let the shaft hang. Assemble support bolts loosely, and by moving the flange end of the shaft up and down, and back and forth, find the center location. Hold the shaft in this position and then torque the bolts to 55 ft. lbs. on support. (Figure 11).

11. Connect drive axles to output shafts using NEW bolts. Torque bolts to 65 ft. lbs.

12. Raise hoist, remove floor stands and lower Motor Home.

13. Install a new "O" ring and install filler tube.

14. Connect battery cables.

15. Fill final drive with 4 pints of Lubricant No. 1051022 or equivalent. Fluid level should be maintained at "Fill Level" stamped on final drive cover.

16. Start engine and check transmission fluid level. Add fluid as necessary.

17. Check for any oil leaks.

## PINION HOUSING SEALS

### REMOVAL

1. Remove final drive. Refer to final drive removal steps 1-13.

2. Remove the bearing housing bolts. Remove the drive pinion and housing as shown in Figure 24. Remove housing from drive pinion. Remove "O" ring seal from O.D. of bearing housing.

3. Using a punch, drive seals out of housing on the opposite side of the rear pinion bearing outer race.

### INSTALLATION

See CAUTION on Page 3C-1 of this section.

1. Position seals as shown in Figure 45 and using Tool J-22212, drive seals into housing until tool bottoms.

2. Position drive pinion into final drive and install Seal Protector J-22236 over end of pinion.

**CAUTION:** Seal protector must be used or inner seal lip will fold between seal case and pinion shaft resulting in a leak.

3. Install new "O" ring over O.D. of bearing housing and install bearing housing over seal protector into position on the housing. Torque bearing housing attaching bolts alternately to 35 ft. lbs. Remove seal protector.

4. Apply Special Seal Lubricant No. 1050169 or equivalent to right output shaft seal.

5. Install final drive. Refer to FINAL DRIVE-INSTALLATION steps 3-17.

## FINAL DRIVE (REMOVED FROM VEHICLE)

### DISASSEMBLY

1. Install adapter J-22296-1 on Differential Holding Fixture J-3289. Mount final drive in holding fixture as shown in Figure 17.

2. Rotate housing so that pinion is up. Install tools as shown in Figure 18, and turn torque wrench several turns and record torque reading. This combined pinion and side bearing pre-load reading will be helpful in determining cause of final drive failure. Remove tools and rotate carrier so that pinion is down.

3. Rotate differential case several times to seat

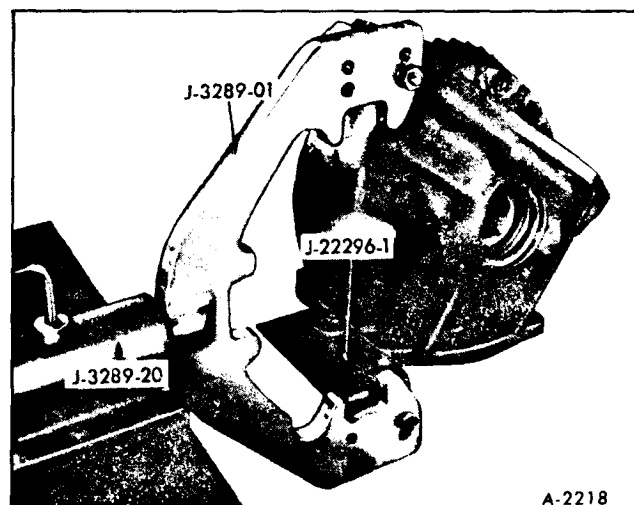

Figure 17—Final Drive Holding Fixture

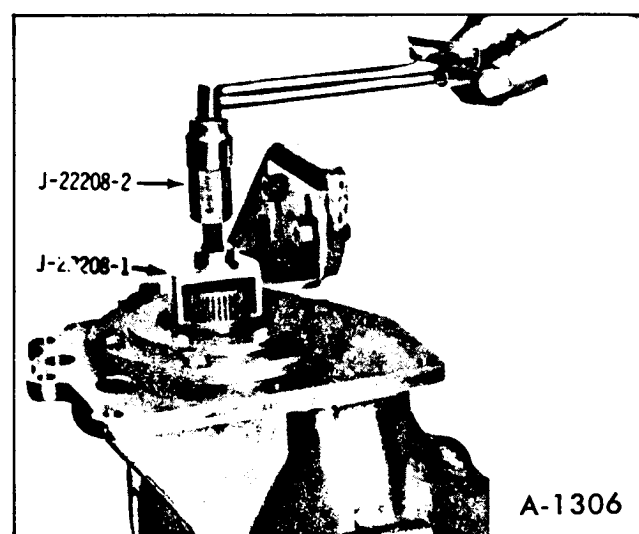

Figure 18—Checking Pinion and Side Bearing Pre-Load

bearings, then mount dial indicator as shown in Figure 19. Use a small button on the indicator stem so that contact can be made near heel end of tooth. Set dial indicator so that stem is in line as nearly as possible with gear rotation and perpendicular to tooth angle for accurate backlash reading.

4. Check backlash at three of four points around ring gear. Lash must not vary over .002" around ring gear.

**NOTE:** Pinion must be held stationary when checking backlash. If variation is over .002" check for burrs, uneven bolting conditions or distorted case and make corrections as necessary.

5. Remove side bearing cap bolts.

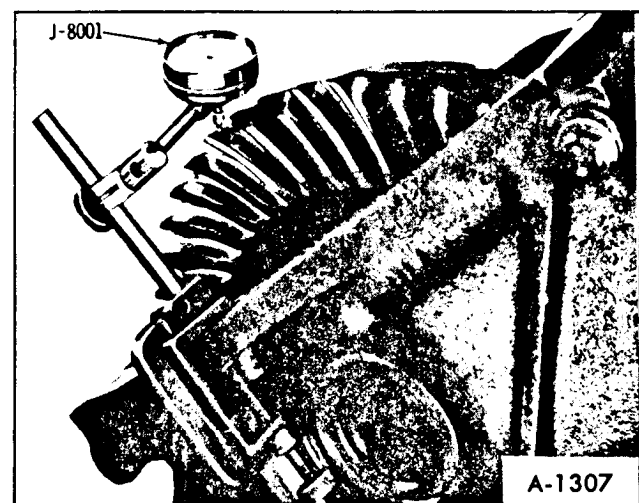

Figure 19—Checking Ring Gear to Pinion Gear Backlash

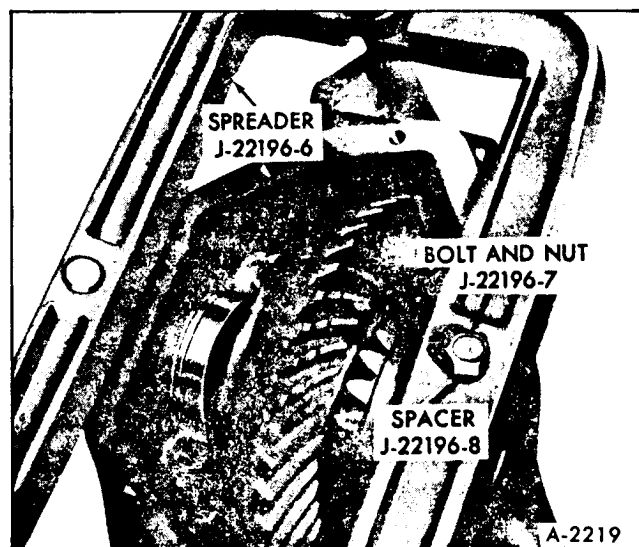

Figure 20—Spreader Installation

**NOTE:** Bearing caps are of same size and must be installed in their original position. Mark right and left bearing caps to identify for reassembling. Keep the original bearing outer races with their corresponding caps.

6. Install spreader on housing as shown in Figure 20.

**NOTE:** Spreader must be modified with Tools J-22196-7-8.

7. Turn the spreader screw to expand spreader until the spacer and shim(s) can be removed from between the right side bearing and the housing. Retain spacers and shims for reassembly.

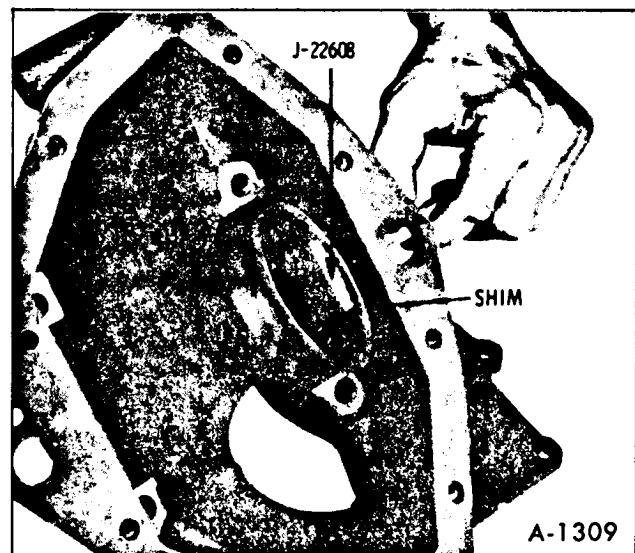

Figure 21—Removing Shims



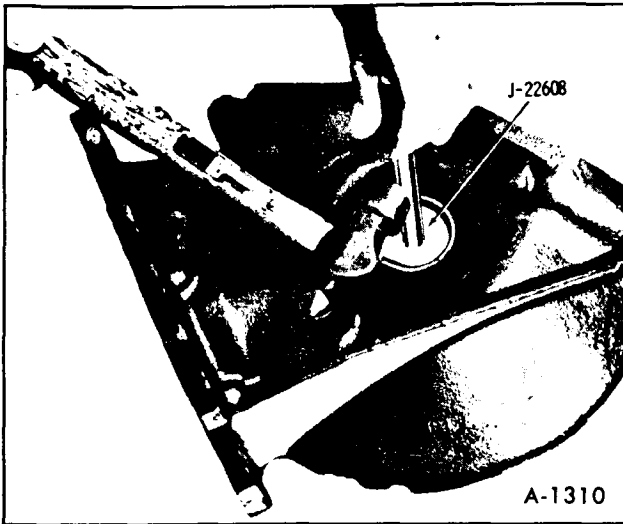

Figure 22—Positioning Tool J-22608

**NOTE:** Spread housing only enough to relieve tension on the spacer and shims. The shims may be removed with Tool J-22608 as shown in Figures 21 and 22.

8. Remove spreader from housing.

9. Remove the spacer and shims, then slide the case assembly to the left, away from the pinion gear. Remove case assembly from housing.

10. Rotate housing so that the pinion is up. Check pinion bearing pre-load as shown in Figure 23. Record the pinion bearing pre-load.

11. Remove the bearing housing bolts. Remove the drive pinion and housing as shown in Figure 24. Remove housing from drive pinion. Remove "O" ring seal from bearing housing.

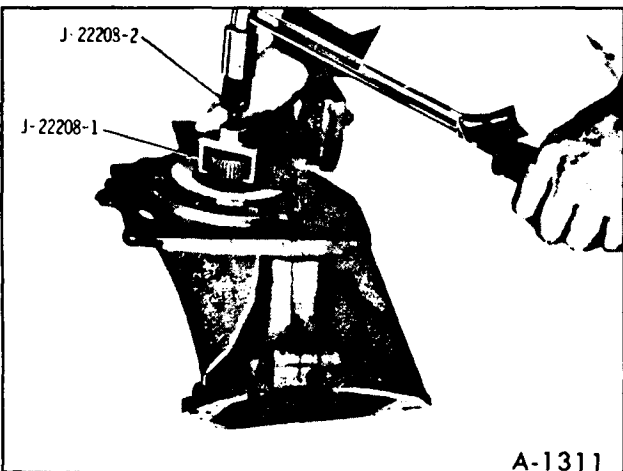

Figure 23—Checking Pinion Pre-Load

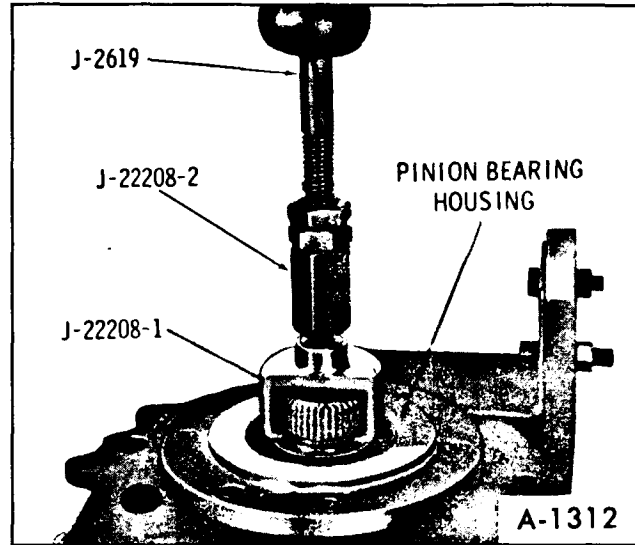

Figure 24—Removing Pinion And Bearing Housing

12. Remove seal and vent pin from housing. (figure 25)

13. Install Tool J-22201 on Slide Hammer J-2619. Position Tool J-22201 as shown in Figure 26, and tighten screw. Remove pinion front bearing outer race.

14. Remove the output shaft oil seals as shown in Figures 5 and 13.

15. Remove the two oil seals from the pinion bearing housing as shown in Figure 27.

16. If necessary to remove the pinion rear outer race, it can be removed as shown in Figure 28.

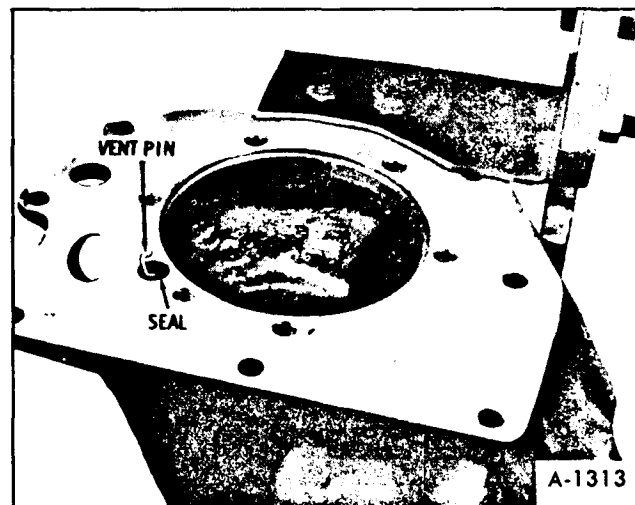

Figure 25—Removing Vent Pin And Seal

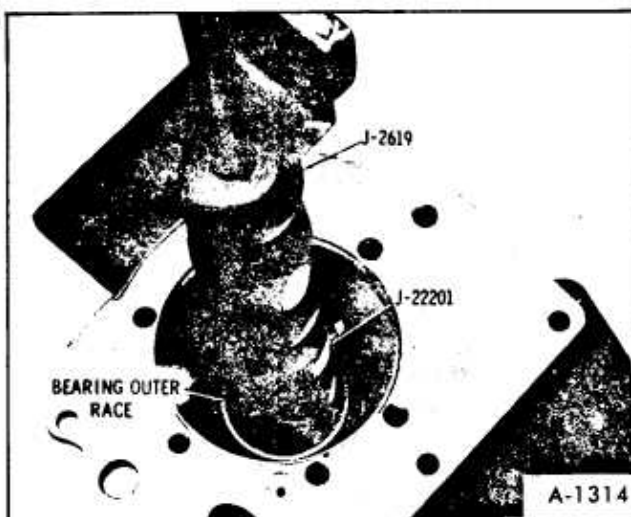

Figure 26—Removing Pinion Front Bearing Outer Race

## PINION BEARINGS

### REMOVAL

1. Remove the pinion front bearing and selective shim as shown in Figure 29. Bearing can be removed without Tool J-8433-1 if a press is available.

2. Remove the pinion rear bearing as shown in Figure 30.

## FINAL DRIVE CASE

### DISASSEMBLY

1. If the side bearings are to be removed, they can be removed as shown in Figures 31 and 32.

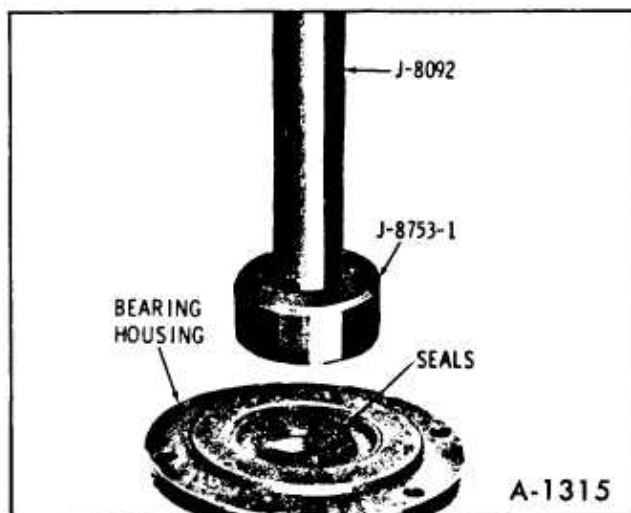

Figure 27—Removing Oil Seals From Pinion Bearing Housing

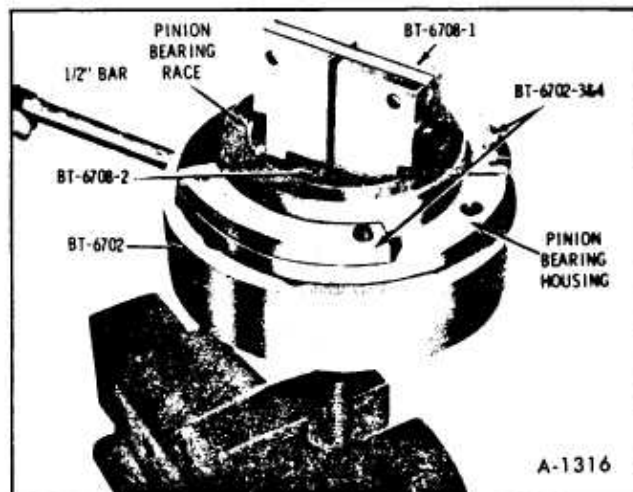

Figure 28—Removing Pinion Rear Bearing Outer Race

2. Mark ring gear and case, then remove all but two of the case to ring gear bolts. Leave two of the bolts, 180° apart, loose.

**NOTE:** Ring gear must be removed to remove pinion and side gears.

3. Position case as shown in Figure 33 and tap lightly on a bench to separate the case from ring gear.

4. Remove the two remaining ring gear bolts and separate ring gear from case.

5. Drive lock pin from pinion shaft with a 3/16" punch (figure 34).

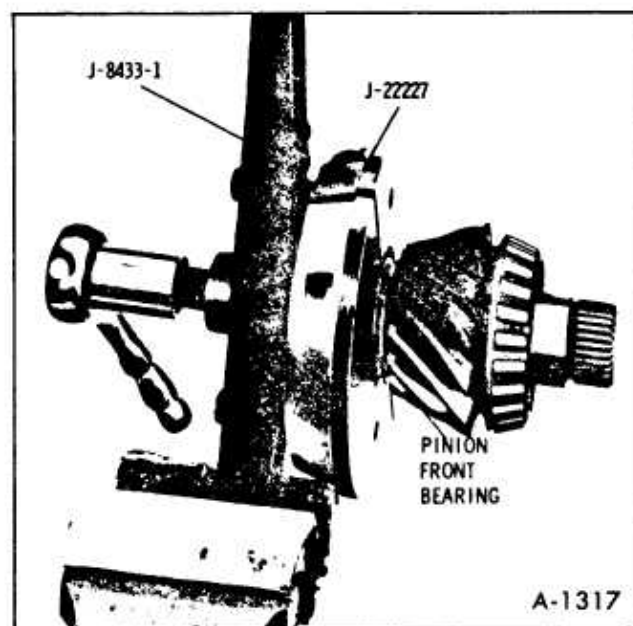

Figure 29—Removing Pinion Front Bearing

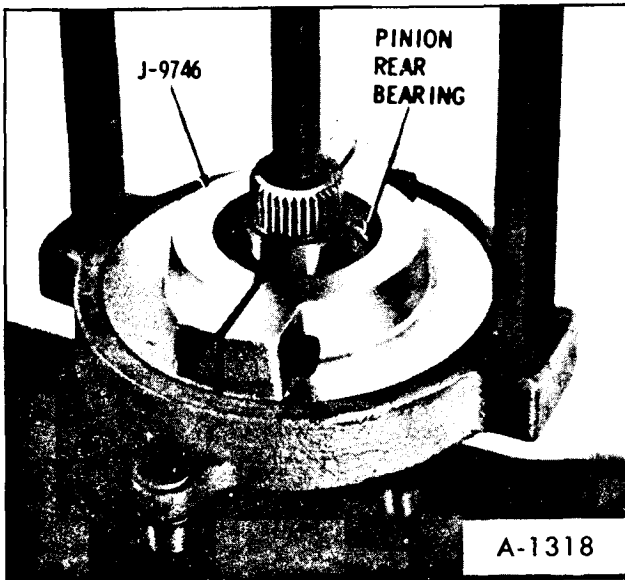

Figure 30—Removing Pinion Rear Bearing

6. Push pinion shaft out of case.

7. Rotate one pinion gear and shim towards access hole in case and remove.

**NOTE:** Keep the corresponding shims and pinion gear together for correct assembly.

8. Remove the other pinion gear and shim.

9. Remove side gears keeping the same thrust washer with the side gear it is mated with. Inspect thrust washers and shims for wear and replace as necessary.

**NOTE:** The left side gear has the threaded retainer that retains the (short) left output shaft.

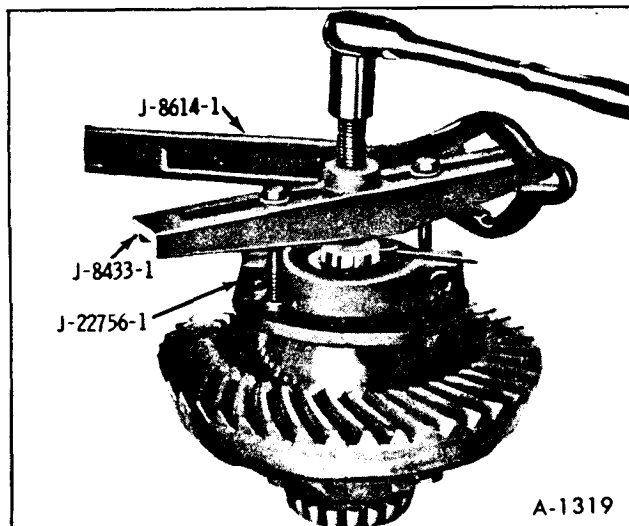

Figure 31—Removing Left Side Bearing

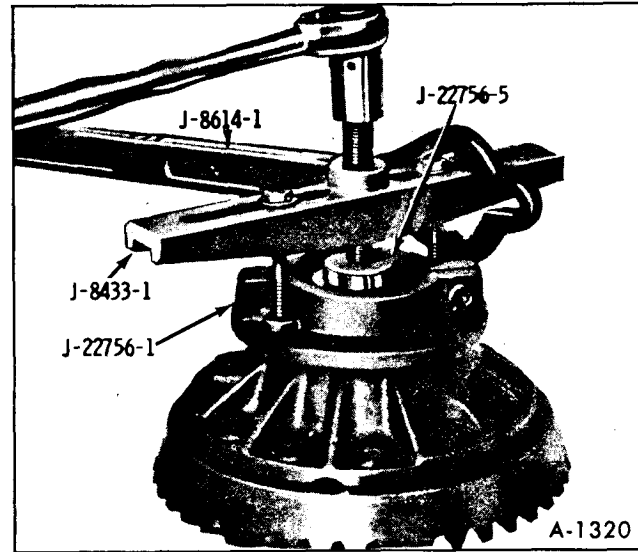

Figure 32—Removing Right Side Bearing

If threaded retainer is to be removed, use a brass drift and hammer to remove from left side gear.

## CLEANING AND INSPECTION

1. Clean all bearings thoroughly in clean solvent. (Do not use a brush). Examine bearings visually and by feel. All bearings should feel smooth when oiled and rotated while applying as much hand pressure as possible.

**NOTE:** Minute scratches and pits that appear on rollers and races at low mileage are due to the initial pre-load and bearings having these marks should not be rejected.

2. Examine the ring gear and drive pinion teeth for excessive wear and scoring. Any of these conditions will require replacement of the gear set.

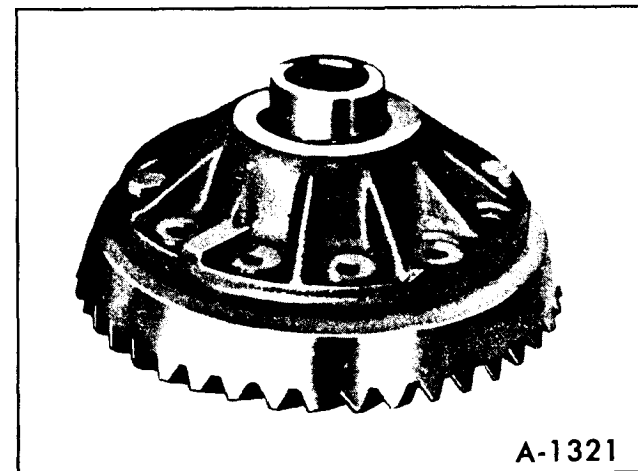

Figure 33—Separating Ring Gear From Case

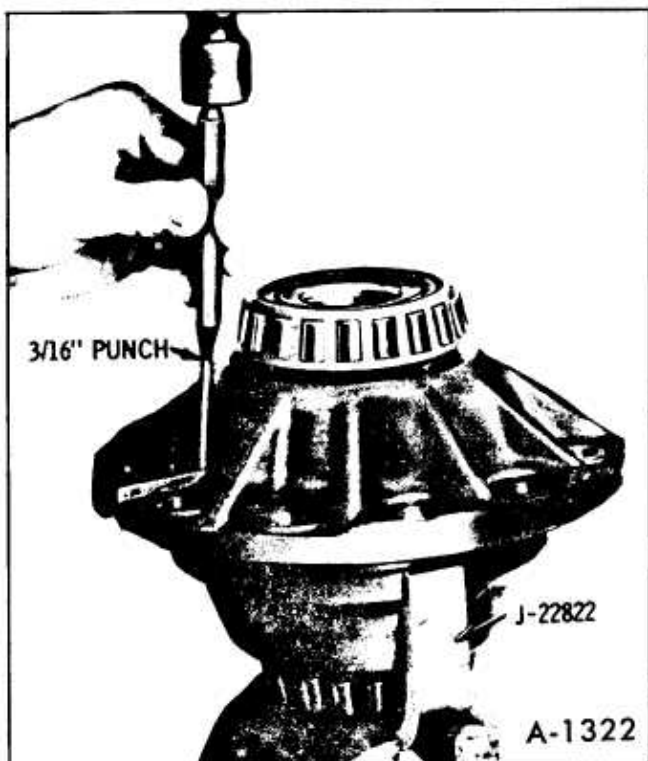

Figure 34—Removing Lock Pin From Pinion Shaft

3. Examine housing bores and remove any burrs that might cause leaks around the OD of the seal.

4. Inspect the differential pinion shaft for unusual wear; also check the pinion and side gears and thrust washers.

5. Side beatings must be a tight press fit on the hub.

6. Diagnosis of a differential failure such as chipped bearings, loose (lapped-in) bearings, chipped gears etc. is a warning that some foreign material is present; therefore, the housing must be thoroughly cleaned and inspected.

## CHECKING PINION DEPTH

1. Install pinion front outer race as shown in Figure 35. Drive race until it bottoms.

2. Lubricate front bearing with final drive lubricant and install into front outer race.

3. Position Tool J-21777-10 on front bearing. Install Tool J-21579 on final drive housing and retain with two bolts. Thread screw J-21777-13 into J-21579 until tip of screw engages Tool J-21777-10. Torque screw J-21777-13 to 20 in. lbs. to pre-load bearing. (figure 36)



Figure 35—Installing Pinion Front Bearing Outer Race

4. Remove dial indicator post from Tool J-21777-1 and install Discs J-21777-22 as shown in Figure 37. Reinstall dial indicator post.

5. Place the gauging discs in the side bearing bores and install the side bearing caps. Torque cap bolts to 65 ft. lbs.

6. Position the dial indicator, J-8001 on the mounting post of the gauge shaft and with the contact rod OFF the gauging area of J-21777-10. Set dial indicator on ZERO, then depress the dial indicator until the needle rotates 3/4 turn clockwise. Tighten the dial indicator in this position. RESET DIAL INDICATOR ON ZERO.

7. Position the gauge shaft assembly in the housing so that the dial indicator contact rod is directly

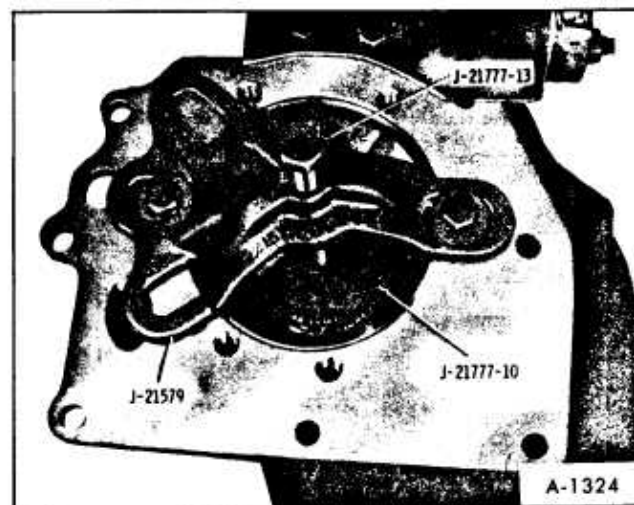

Figure 36—Pre-Loading Pinion Front Bearing

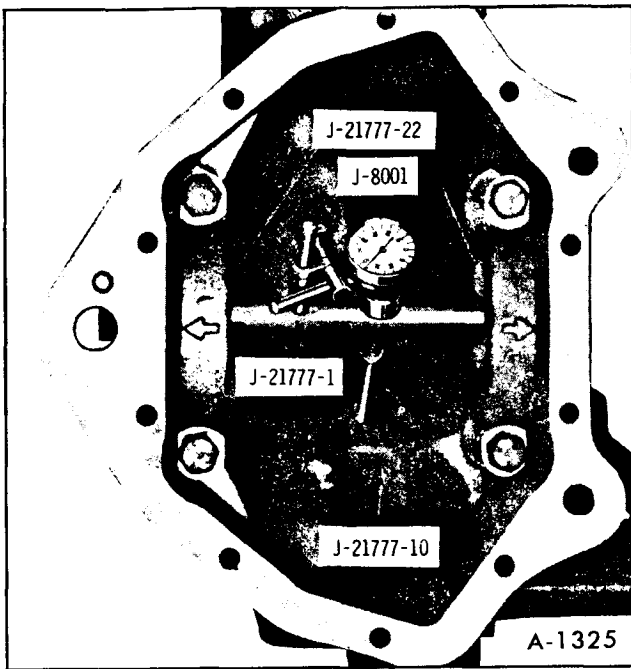

Figure 37—Pinion Depth Gauge Tool Installation

in line with the gauging area BUT NOT ON and the discs seated fully in the side bearing bores.

8. Rotate the gauge shaft assembly until the dial indicator rod contacts the gauging area of J-21777-10. Rotate gauge shaft slowly back and forth until the dial indicator reads the greatest deflection.

9. At the point of greatest deflection, read the dial indicator directly for pinion depth.

10. Select the correct pinion shim to be used during pinion reassembly on the following basis:

a. If a service gear set or a production gear set with no paint marking, on outer circumference of ring gear is being used, the correct shim will have a thickness equal to the indicator gauge reading found in Step 9. (figure 38)

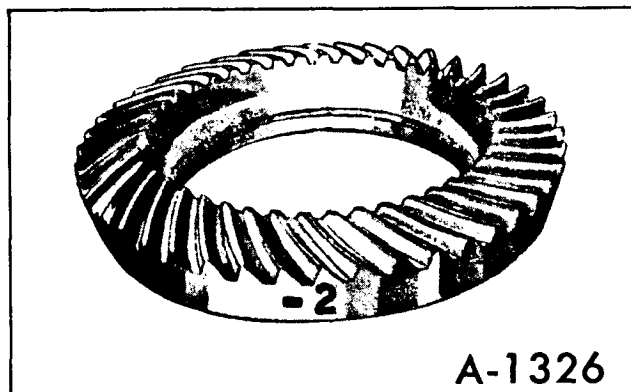

Figure 38—Location of Pinion Marking

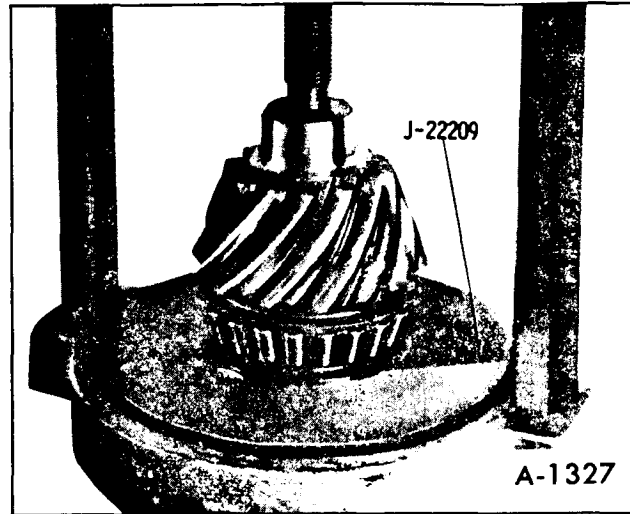

Figure 39—Installing Pinion Rear Bearing

b. If the gear set being used is painted “+” or “-”, the correct shim will be determined as follows.

Ring gear painted “+” (plus), the shim thickness indicated by the dial indicator on the pinion setting gauge must be **INCREASED** by the amount painted on the ring gear. (figure 38)

Ring gear painted “-” (minus), the shim thickness indicated by the dial indicator on the pinion setting gauge must be **DECREASED** by the amount painted on the ring gear. (figure 38)

11. Remove pinion depth checking tools and front bearing from housing.

12. Install rear pinion bearing as shown in Figure 39.

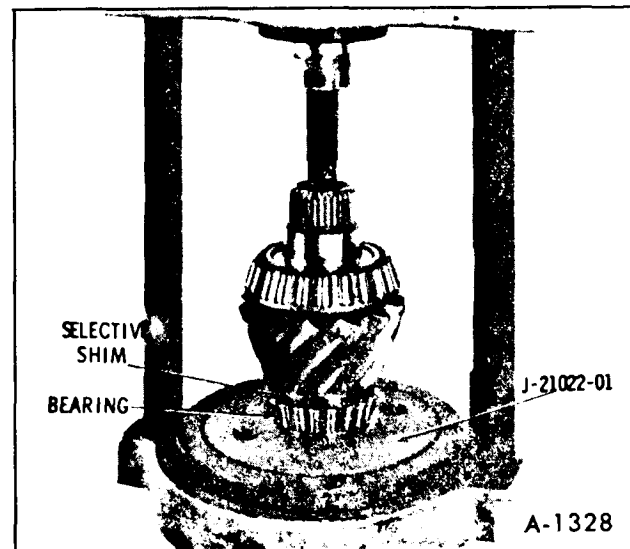

Figure 40—Installing Pinion Front Bearing And Shim

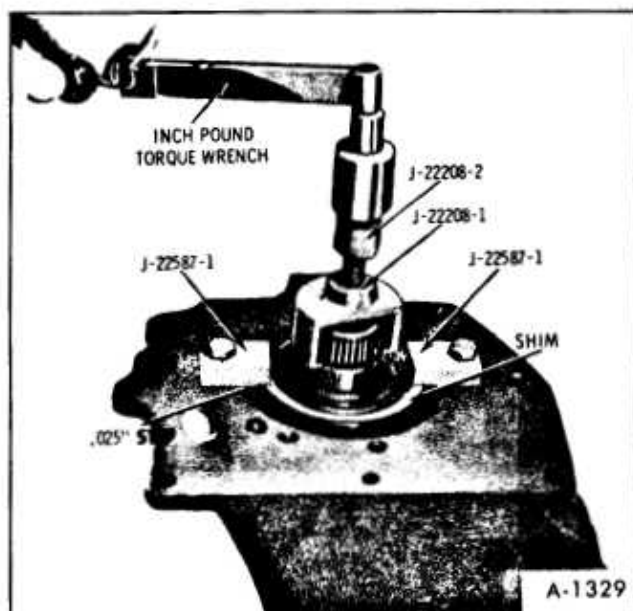

Figure 41—Checking Shim Thickness for Pinion Bearing

**NOTE:** Shims are available from .040" to .070" in increments of .002".

13. Position correct shim on drive pinion and install the drive pinion front bearing as shown in Figure 40.

## PINION BEARING PRE-LOAD ADJUSTMENT

1. The pre-load shim will have to be changed or checked any time the following parts have been replaced:

- a. Ring gear and pinion.
- b. Pinion bearings (front or rear).
- c. Rear bearing retainer.
- d. Final drive housing.

2. Position pinion bearing race on pinion bearing and install Tool J-22587-1 as shown in Figure 41. Using a feeler gauge check thickness between bearing race and Tool J-22587-1. Loosen bolts holding Tool J-22587-1 so that pinion bearing shim can be installed. Shims are available in sizes from .036" to .070" in increments of .002". Add shims until a pre-load of 2 to 5 in. lbs. for used bearings, 2 to 15 in. lbs. for new bearings is obtained. **RECORD FINAL SHIM THICKNESS.**

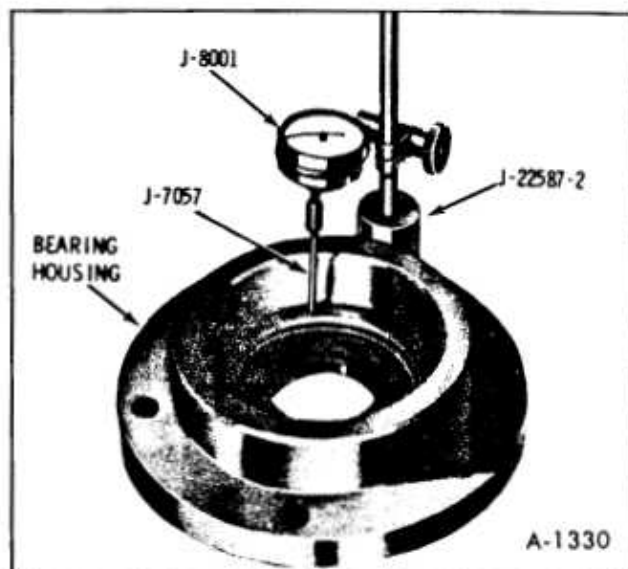

Figure 42—Checking Inner Flange Of Housing

3. Remove Tool J-22587-1.

4. With dial indicator J-8001 and extension J-7057, attach existing dial indicator post to Tool J-22587-2. (figure 42) While holding contact studs (three) of Tool J-22587-2 firmly against shoulder of bearing housing, position dial indicator as shown in Figure 42 and rotate dial to ZERO.

5. Carefully lift dial indicator assembly over flange of bearing housing and position assembly as shown in Figure 43. With the three contact studs held firmly against shoulder of bearing housing, rear the dial indicator deflection. **RECORD THIS DEFLECTION.**

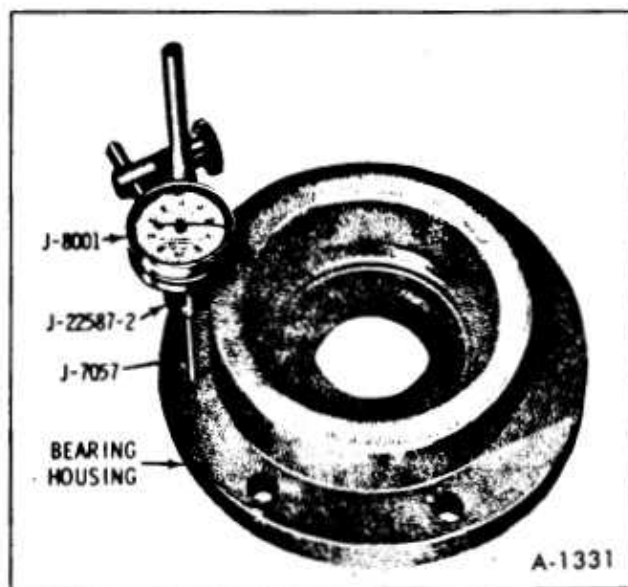

Figure 43—Checking Outer Flange Of Housing

The following is an example of finding the correct pinion bearing pre-load with information obtained above.

(Shims recorded in Step 2) .....	.053"
(Diff. in housing - Step 5).....	+ .024"
.....	.077"
(Built in step in Tool J-22587-1) .....	-.025"
.....	.052"
(To compensate for increase in pre-load when installing housing).....	-.002"
(Actual pinion bearing pre-load shim required).....	.050"

6. Position shim into bearing housing and install pinion rear bearing outer race as shown in Figure 44.

7. Install seals into bearing housing as shown in Figure 45.

8. Install a new "O" ring seal on the bearing housing.

9. Install seal and vent pin on face of housing. (figure 25)

10. Install seal protector J-22236 over drive pinion and install bearing housing over seal protector and position on the final drive housing. Torque the attaching bolts to 35 ft. lbs. (figure 46). Remove Tool J-22236.

**CAUTION:** Seal protector must be used or inner seal lip will fold between seal case and pinion shaft resulting in a leak.

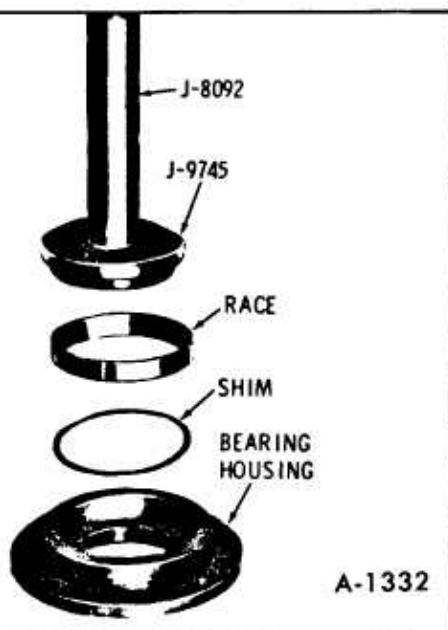

Figure 44—Installing Pinion Rear Bearing Outer Race

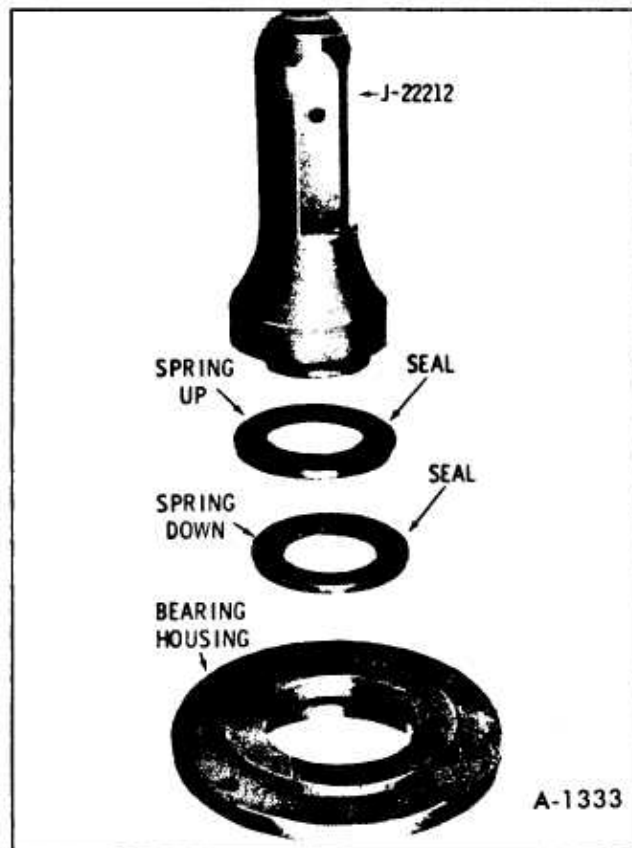

Figure 45—Installing Seals Into Bearing Housing

11. Reinstall Tool J-22208-1-2 and recheck pinion pre-load. Must be 2 to 5 in. lbs. for used bearings, 2 to 15 in. lbs. for new bearings (figure 23)

## CASE ASSEMBLY

### Side Bearing Installation

1. Install the side bearings as shown in Figures 47 and 48. Drive evenly until seated.

**NOTE:** Do not let the bearing cock as it is being driven on. Excess metal could be wiped off the mounting surfaces and the bearing could become loose on the case.

### SIDE AND PINION GEARS

#### Installation

Before assembling the differential case, lubricate all parts with Lubricant No. 1051022 or equivalent.

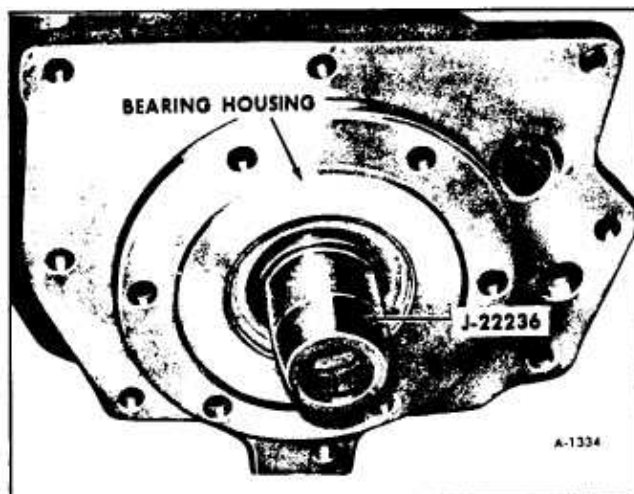

Figure 46—Installing Bearing Housing Into Final Drive Housing

1. Place side gear thrust washers over side gear hubs and install side gears in case. If same parts are reused, install in original sides.

**NOTE:** Position side gear with threaded rotainer on left side of case.

2. Position one pinion (without shims) between side gears and rotate gears until pinion is directly opposite from loading opening in case. Place other pinion between side gears so that pinion shaft holes are in line; then rotate gears to make sure holes in pinions will line up with holes in case.

3. If holes line up, rotate pinions back toward loading opening just enough to permit sliding in pinion gear shims.

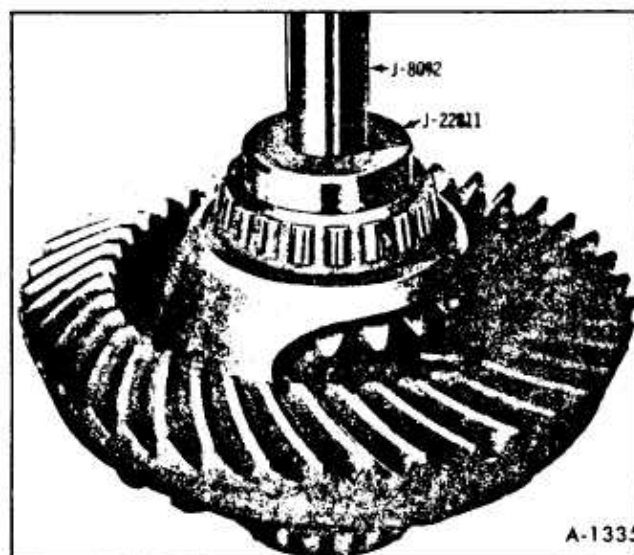

Figure 47—Installing Left Side Bearing

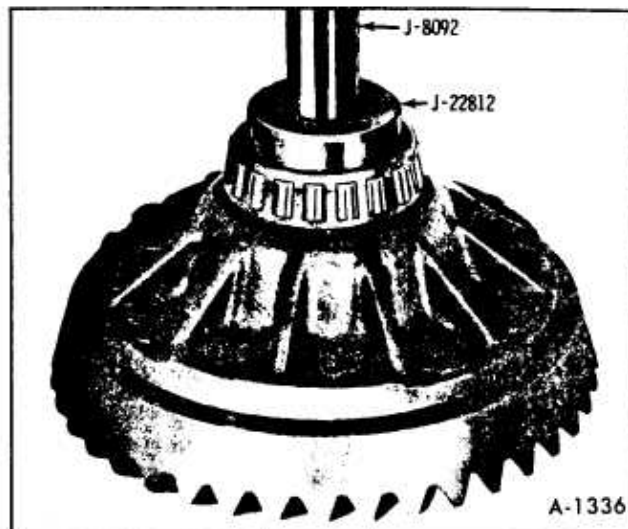

Figure 48—Installing Right Side Bearing

4. Install pinion shaft. Drive pinion shaft retaining lock pin into position. (figure 49)

## RING GEAR

### Installation

1. After making certain that, mating surfaces of case and ring gear are clean and free of burrs, install three (3) 7/16-20 x 1-3/4 bolts as shown in Figure 50 to correctly position ring gear.

2. Install Tool J-22822 into a vise and place case assembly over tool as shown in Figure 51. Install

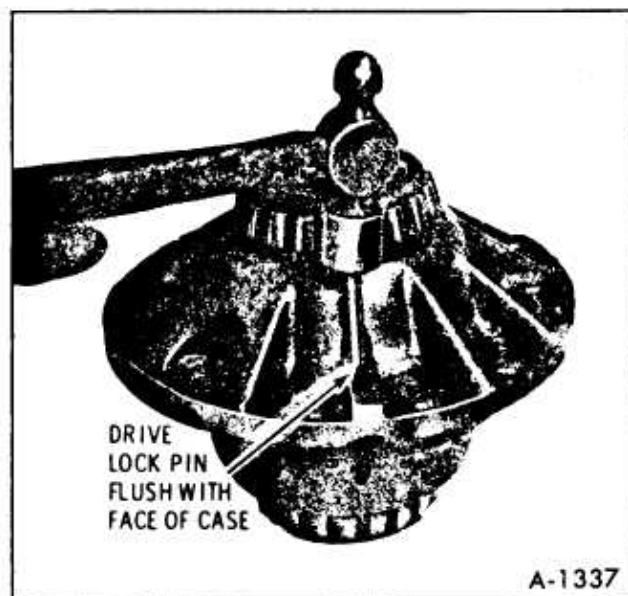

Figure 49—Installing Lock Pin



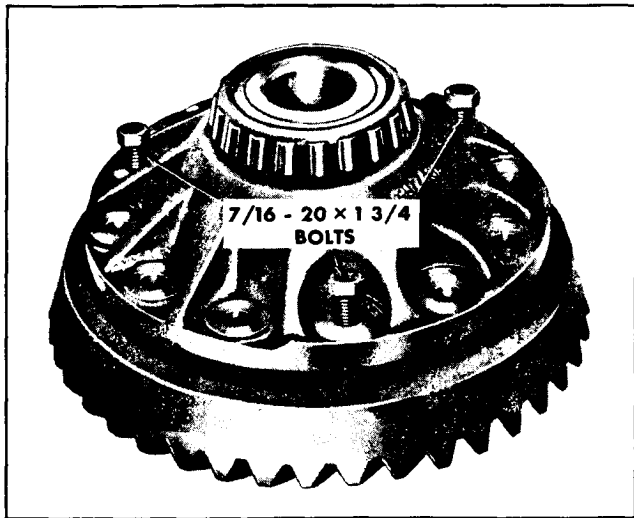

Figure 50—Installing Ring Gear to Case

NEW ring gear attaching bolts in remaining holes and then remove three (3) 7/16-20 x 1-3/4 bolts. Install remaining three NEW bolts into ring gear and torque bolts alternately in progressive stages to 85 ft. lbs.

**NOTE:** Tool J-22822 must be used to correctly torque ring gear bolts.

## SIDE BEARING PRE-LOAD ADJUSTMENT

Differential side bearing pre-load is adjusted by means of shims placed between the side bearing and housing. Shims are used on both sides and 19 shims are available in increments of .002" from .038" to .074". Two spacers .140"  $\pm$ .005", are used one on the right side and one on the left side. By adding or subtracting the same amount of shims from both

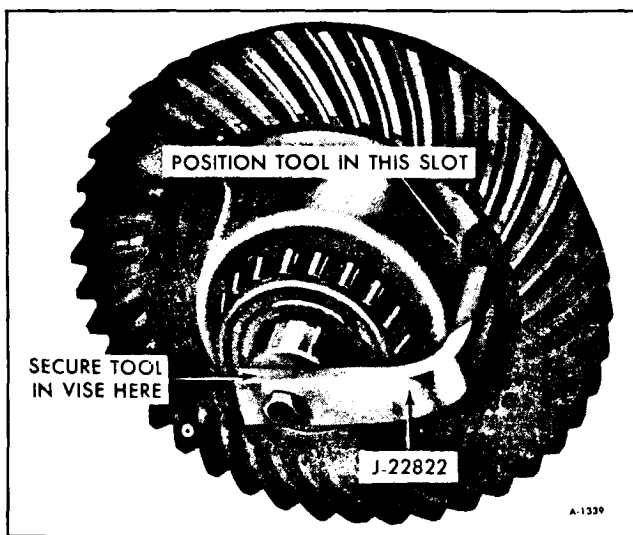

Figure 51—Installing Tool J-22822

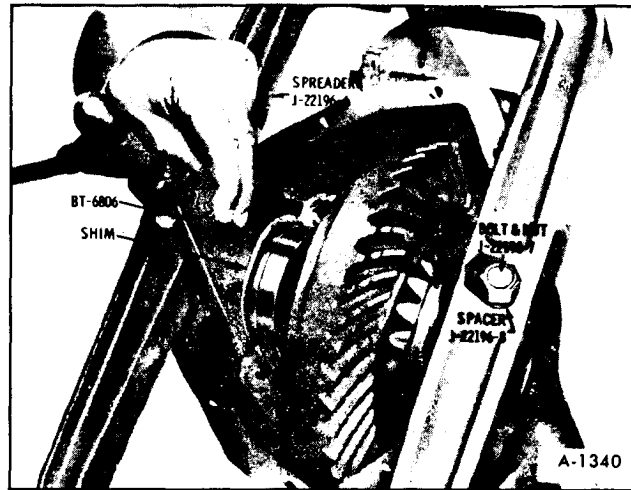

Figure 52—Spreading Housing For Shim Installation

sides, the ring gear to pinion backlash will not change.

1. Before installing the case assembly, make sure that side bearing surfaces in the housing are clean and free of burrs. Side bearings must be oiled with Lubricant No. 1051022 or equivalent. Turn fixture and housing so cover side is up.

2. Place differential case and bearing assemblies in position in housing.

3. Install the original spacers on left and right side. If the recorded side bearing pre-load was correct on disassembly, the original shims may be used.

4. Install Spreader J-22196 on housing and spread housing just enough so that shim can be inserted between the spacer and the housing. (figure 52)

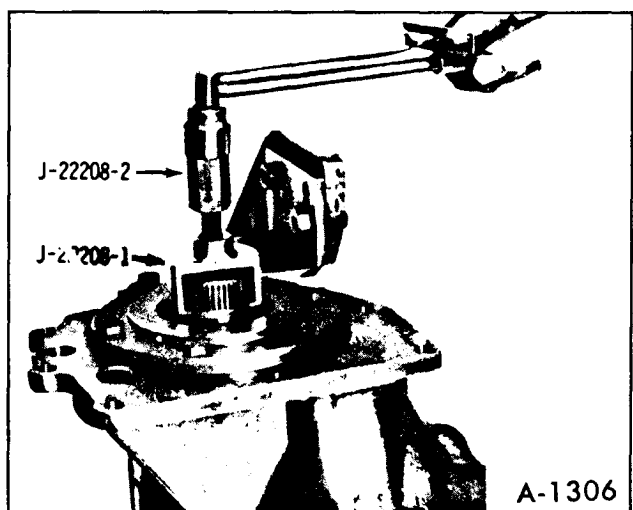

Figure 53—Checking Pinion And Side Bearing Pre-Load

5. Release tension on spreader tool install side bearing caps, and torque cap bolts to 65 ft. lbs., then check pre-load as shown in Figure 53. Pre-load should be 10 to 15 in. lbs. for new bearings, 5 to 7 in. lbs. for old bearings over the pinion bearing pre-load.

6. If pre-load is not within specifications, obtain proper combination of shims, either thicker or thinner, until side bearing pre-load is 10 to 15 in. lbs. for new bearings, 5 to 7 in. lbs. for old bearings over the pinion bearing pre-load.

## BACKLASH ADJUSTMENT

1. Rotate differential case several times to seat bearings, then mount dial indicator as shown in Figure 54. Use a small button on the indicator stem so that contact can be made near heel end of tooth. Set dial indicator so that stem is in line as nearly as possible with gear rotation and perpendicular to tooth angle for accurate backlash reading.

2. Check backlash at three or four points around ring gear. Lash must not vary over .002" around ring gear.

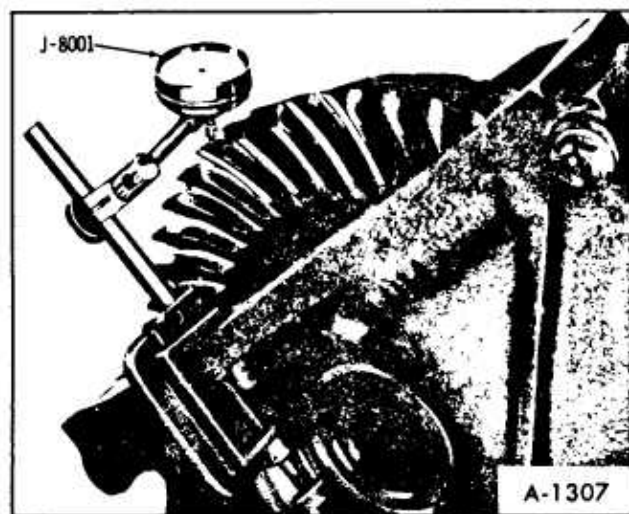

Figure 54—Checking Ring Gear To Pinion Gear Backlash

**NOTE:** Pinion must be held stationary when checking backlash. If variation is over .002" check for burrs, uneven bolting conditions or distorted case and make corrections as necessary.

3. Backlash at the point of minimum lash should be between .005" and .009" for all new gears. If original ring gear and pinion was installed, backlash should be set at the same reading obtained in Step 4 of the Final Drive Disassembly procedure, provided reading was within specifications.

4. If backlash is not within specifications, correct by increasing thickness of one differential shim and decreasing thickness of other shim the same amount. This will maintain correct differential side bearing pre-load.

For each .001" change in backlash desired, transfer .002" in shim thickness. To decrease backlash .001" INCREASE thickness of right shim .002" and DECREASE thickness of left .002". To increase backlash .002" DECREASE thickness of right shim .004" and INCREASE thickness of left shim .004".

5. When backlash is correctly adjusted, remove spreader. Install the bearing caps and bolts. Torque to 65 ft. lbs.

6. Install new output shaft seals as shown in Figure 10 and 14.

**NOTE:** Left output shaft seal is installed with vent hole toward top of final drive housing in the in-car position.

7. Install new gasket on housing. Install cover, torque cover bolts to 25 ft. lbs.

Fill final drive with fluid to "FILL LEVEL" line stamped on cover near fill hole.

Use only Gear Lubricant No. 1051022 or equivalent.

**NOTE:** If final drive was removed without removing the transmission, do not install gasket, cover or lubricant until final drive has been installed in Motor Home.

GMC

MOTOR  
HOME

SERVICE

# SECTION 4

## REAR SUSPENSION

Contents of this section are listed below:

SUBJECT	PAGE NO.
System Description .....	4-1
Trouble Diagnosis .....	4-4
Rear Suspension Trouble Diagnosis Chart.....	4-5
Component Removal.....	4-6
Compressor Overhaul .....	4-12
Height Control Valve Overhaul .....	4-15
Component Installation.....	4-20
On-Vehicle Adjustments .....	4-25
Periodic Maintenance .....	4-27
Rear Suspension Torque Specifications .....	4-28

## SYSTEM DESCRIPTION

### AIR BELLOWS

The rear suspension system (figure 1) on the vehicle consists mainly of air bellows, height control valves, control arms, and shock absorbers. The system operates automatically as load varies, to retain frame at proper ride height.

The air bellows are mounted between the control arms, for the tandem rear wheels. On each side of the air bellows is a piston which is connected direct to the control arm.

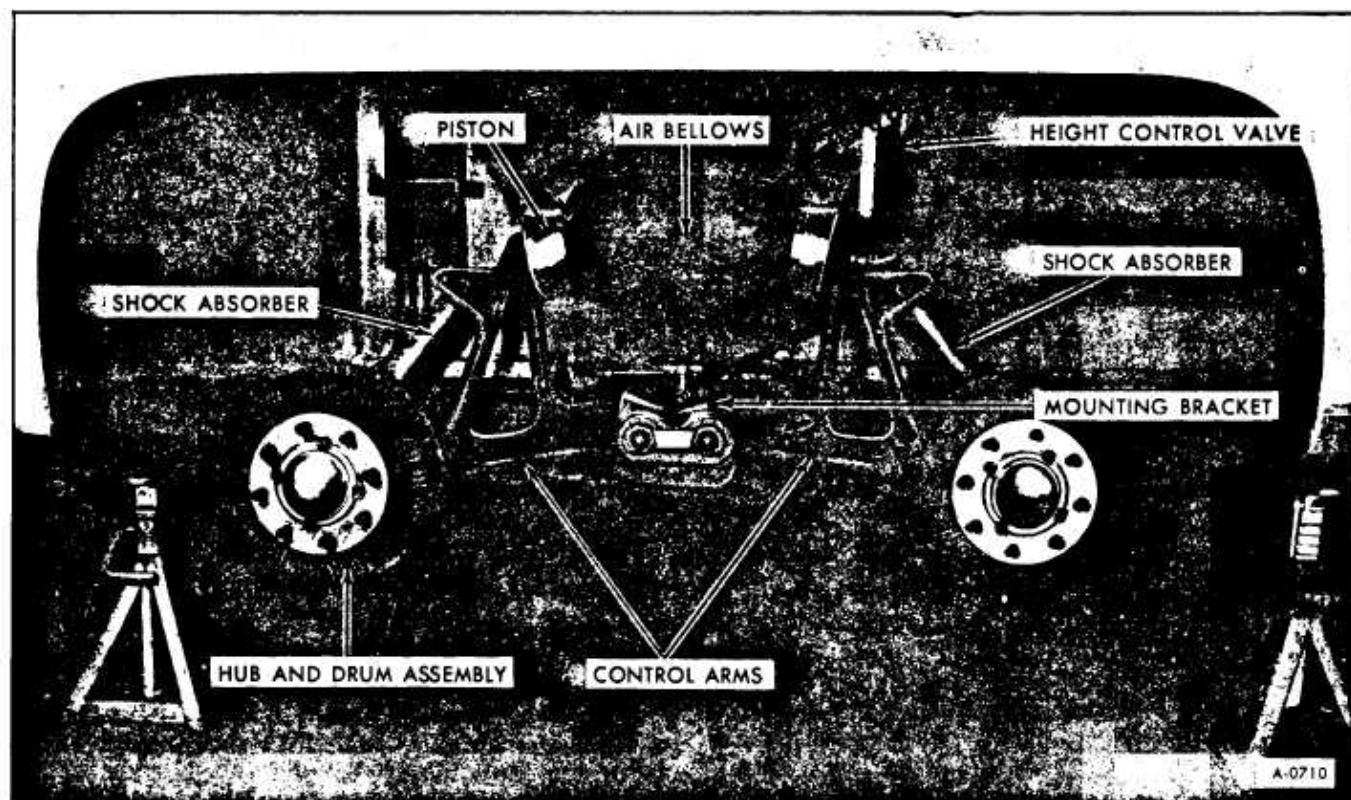

Figure 1-Rear Suspension (Left-Side View)

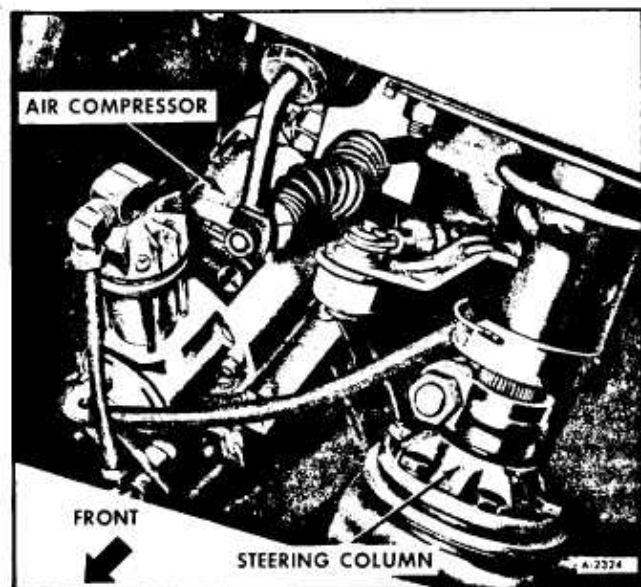

Figure 2-Air Compressor Location

## AIR COMPRESSOR

Compressed air for the system is supplied by a electric compressor which operates when the ignition key is in the "ON" or "ACCESSORY" position. It is a demand-type compressor which will start compressing air when the pressure in the system drops below 100 psi, and will shut off when the pressure reaches 120 psi. Air compressor for the system is located behind the left-front access door.

## AIR RESERVOIR

The purpose of the air reservoir is to provide a place to store compressed air for the rear suspension. The reservoir is located on the right-hand side of the motor home in front of the front wheel. The reservoir will allow the rear suspension to adjust without the air compressor operating.

Another purpose of the reservoir is to provide a place where the air, heated during compression, can cool and the water vapor can condense. Drain reservoir monthly.

## AIR BELLOWS

The air bellows serve as a flexible connection between the two control arms on each side of suspension bracket. The flexing of the air bellows allows the control arms to move up and down in relation to the frame. This action absorbs road shocks in the same manner as an inflated rubber tire cushions shock caused by road roughness.

## SHOCK ABSORBERS

A double acting shock absorber is used at each wheel on the rear suspension. The shocks are mounted to the top of the control arms and to the frame at the bottom.

The shock absorbers are gas filled cell type shocks. They are filled with a calibrated amount of

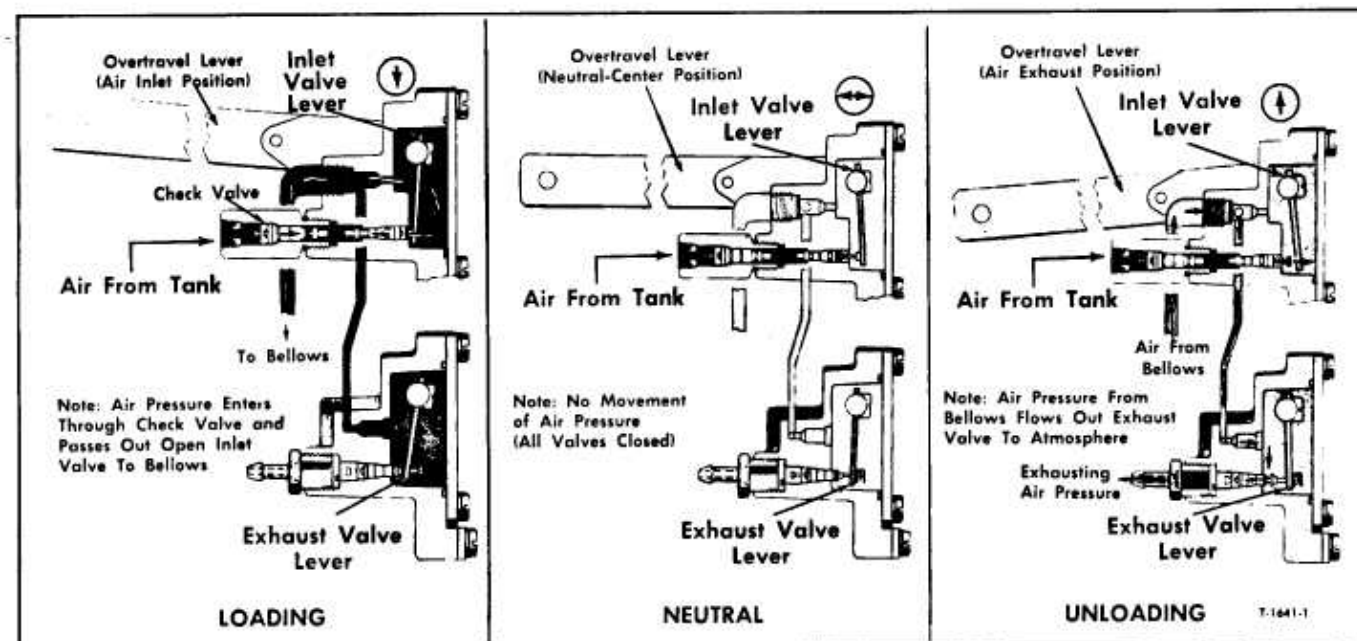

Figure 3-Operation of Height Control Valve

fluid and sealed during production. They are non-adjustable, non-refillable and cannot be disassembled the only service they require is replacement if they have lost their resistance, are damaged or leaking fluid.

## HEIGHT CONTROL VALVE

Height control valve automatically maintains a constant vehicle height by controlling the flow of compressed air into or out of suspension system air bellows. A delay piston in each valve provides a momentary delay in intake and exhaust valve action: therefore, air in bellows is exhausted only during load changes and not during intermittent road bumps.

The height control valve contains an intake valve, air bellows outlet, exhaust valve, delay piston, and overtravel control body. The overtravel control body contains a spring-loaded nylon piston which protects valve parts if overtravel lever is moved beyond normal operating range.

## HEIGHT CONTROL VALVE OPERATION

### Loading

When vehicle is being loaded, frame tends to settle. Since valve is linked to control arm, and valve is bolted to wheel well, valve moves downward with frame as vehicle is loaded. As valve arm and control shaft turns, a force is applied to the delay piston which moves slowly and allows the intake valve lever to move against the intake valve core. As pin is pushed in, air pressure flows through height control valve into bellows. Increased air pressure expands the bellows and raises frame.

Inlet valve is "PROTECTED" by check valve in inlet adapter. Light spring in core freely admits reservoir air, but return flow of air is blocked.

### Neutral Position

As increased air pressure expands bellows and lifts frame, the height control valve moves upward with frame. As frame is returning to normal ride height, valve arm and shaft return to a neutral position. Inlet valve lever also moves away from inlet valve core and inlet valve closes. This stops the flow of air into bellows. The exhaust valve remains closed.

Since the exhaust valve is closed, and the check valve in the inlet adapter prevents compressed air from returning to air reservoir, air is trapped in bellows and in valve. No further valve action or air pressure change takes place until load is increased or decreased, moving valve arm out of neutral position for four seconds or more to actuate intake valve or exhaust valve.

### Unloading

When part of load is removed, air pressure in bellows lifts frame. Valve arm, linked to axle, is pulled downward from neutral position. This applies a force on the delay piston, which moves it slowly. The exhaust valve lever moves with the delay piston. The outer end of exhaust valve lever fits around stem of exhaust valve core. As soon as lever moves beyond free-travel range, lever pulls on stem and opens exhaust valve. Inlet valve remains closed. Compressed air from bellows then flows through the open exhaust valve and out exhaust fitting to atmosphere. As the compressed air is exhausted from bellows, the frame lowers until overtravel lever and shaft are again in normal (neutral) position.

### Valve Arm Free Travel

With vehicle in motion and frame at normal ride height, control valve arm and shaft are in neutral position. Small irregularities in road causes slight up and down movement of valve arm. Clearances are provided between operating levers and cores of inlet and exhaust valves to permit 3/8-inch up or down movement of valve arm, from neutral position without causing valve action. This compensates for small road bumps. The bumps are absorbed by tires and bellows without causing movement of compressed air either into or out of suspension system.

### Hydraulic Delaying Action

Operation of delay piston in height control valve prevents change of bellows air pressure as a result of momentary road shocks, conserves air supply, and adds life to valve. The nylon piston moves inside cylinder containing a silicone type fluid. A flapper valve on either end of piston allows displacement of fluid or act as a check valve, depending on direction piston moves. Delay piston is moved by piston pin,

that is threaded into overtravel shaft. A 4 to 18 second delay results from the closing of one valve to the opening of other valve.

Overtravel piston is held against flat side of overtravel shaft by two springs inside piston. Piston keeps overtravel shaft in proper position relative to valve arm. Piston also allows valve arm to rotate through a complete circle, if necessary, without damaging parts inside valve.

## POWER LEVEL OPERATION

The power level option consists of two, in-line valves which override the height control valve. These valves allow the operator to raise or lower each side of the rear suspension from the driver's seat. This is accomplished by bypassing the height control valve and adding or expelling air directly from the bellows. For a diagram of air lines see figure 43.

## TROUBLE DIAGNOSIS

### AIR LEAKS

With the air system at normal operating pressure coat all suspension air line connections with soap and water solution. Air leakage will produce soap bubbles. No leakage is permissible. Leakage at air line connections can sometimes be stopped by tightening connection. If this does not stop the leak replace the affected fittings.

### SHOCK ABSORBERS

See Section 3A "FRONT SUSPENSION" for trouble diagnosis of shock absorbers.

### HEIGHT CONTROL VALVE AIR LEAKAGE CHECK

**NOTE:** Air leakage check can be performed for air line connections, only when valve is installed on vehicle. The following instructions explain procedure for performing air leakage check on valve when removed from vehicle.

1. Clean exterior of valve assembly.

2. Connect air pressure line to air inlet port, then open the air pressure (90-120 psi).

3. Submerge valve assembly in a container of water, then watch for air bubbles when the valve arm is in center (neutral) position. No air should escape from any point of valve assembly.

4. If bubbles appear from the bellows port, this is an indication the air inlet valve assembly is defective and must be replaced.

5. Remove air pressure line from air inlet fitting and connect it to the bellows port. If bubbles appear at the air inlet check valve port, this is an indication that check valve unit is defective and must be replaced.

6. If bubbles appear at the exhaust port it is an indication the exhaust valve assembly is defective and must be replaced.

7. If bubbles appear around edge of valve cover plate, the cover plate gasket must be replaced.

8. If no leaks are detected, remove valve assembly from water, then with air pressure still connected to bellows port, actuate valve arm to expel any water which may have entered exhaust valve chamber. Remove air line and connect it to air inlet port and repeat operation to remove water from air inlet valve chamber.

# REAR SUSPENSION TROUBLE DIGNOSIS CHART

Problem	Possible Cause	Correction
No air pressure in air reservoir-unit not operating.	1. Open circuit breaker.	1. Find cause of circuit breaker being "OPEN" and correct it. Circuit breaker is located behind the glove box door.
	2. Faulty wiring.	2. Check to see that wiring is intact.
	3. Low battery.	3. The compressor runs off the automotive battery, check its condition and correct as necessary.
	4. Faulty or pitted contacts on pressure switch.	4. Replace pressure switch.
	5. Motor has developed an open circuit.	5. Motor brushes or commutator worn out. Replace motor.
No air pressure in air reservoir-unit is operative.	1. Air leak in system.	1. Eliminate air leaks in system as explained earlier in this section.
	2. Compressor valve seat or valve spring worn or broken.	2. Replace valve seat and/or valve spring.
	3. Piston rings are worn-air leaks heavily by rings.	3. Replace piston rings.
	4. Pressure switch contacts are pitted causing improper compressor action.	4. Replace pressure switch. ↙
	5. Pressure switch not properly adjusted	5. Adjust pressure switch settings to operate at the 100-120 psi range. ↘

Problem	Possible Cause	Correction
Air pressure in tank-unit operating erratically-pump takes to long to pressurize tank.	1. Air leak in system.	1. Eliminate air leaks in system as described earlier in this section.
	2. Compressor valve seat valve broken or worn.	2. Replace valve seat and/or valve spring.
	3. Piston rings are worn-air leaks heavily by rings.	3. Replace piston rings.
	4. Pressure switch contact are pitted causing improper compressor action.	4. Replace pressure switch.
	5. Battery voltage to low to operate motor.	5. Charge battery.
	6. Bearing failure may cause unit to seize occasionally and break loose if galling occurs.	6. Replace bearings or parts with bearings.

## COMPONENT REMOVAL

**CAUTION:** Whenever it is necessary to support the rear suspension with jack stands or other supporting equipment, as shown in figure 1, be sure jack stands are used only at a junction point(s) of the frame rail and crossmember. Failure to locate jack stand as instructed could result in damage to frame of vehicle.

### PRESSURE SWITCH REMOVAL

1. Raise left front corner of vehicle.
2. Release pressure from reservoir through its drain tank.
3. Remove air line to compressor switch assembly. Remove wiring to compressor switch assembly.
4. Referring to Figure 4, Remove three bolts on vertical bracket to radiator mounting. (There are weldnuts on inside of radiator mounting.)
5. Remove two bolts and nuts from lower supporting bracket.

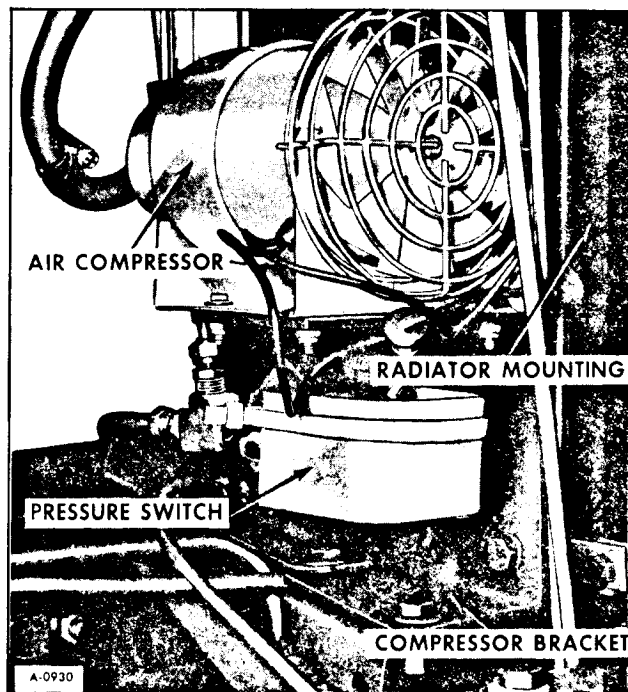

Figure 4—Air Compressor Installation



6. Remove compressor and pressure switch assembly.

7. With assembly on bench, disconnect motor lead in pressure switch, and ground wire from mounting bracket.

8. Referring to figure 4, remove four nuts and bolts from compressor mounting bracket.

9. Remove air compressor.

10. Pressure switch assembly can be removed by disconnecting fitting at mounting bracket.

## AIR RESERVOIR REMOVAL

1. Slowly open drain cock on reservoir (figure 5) to expel air.

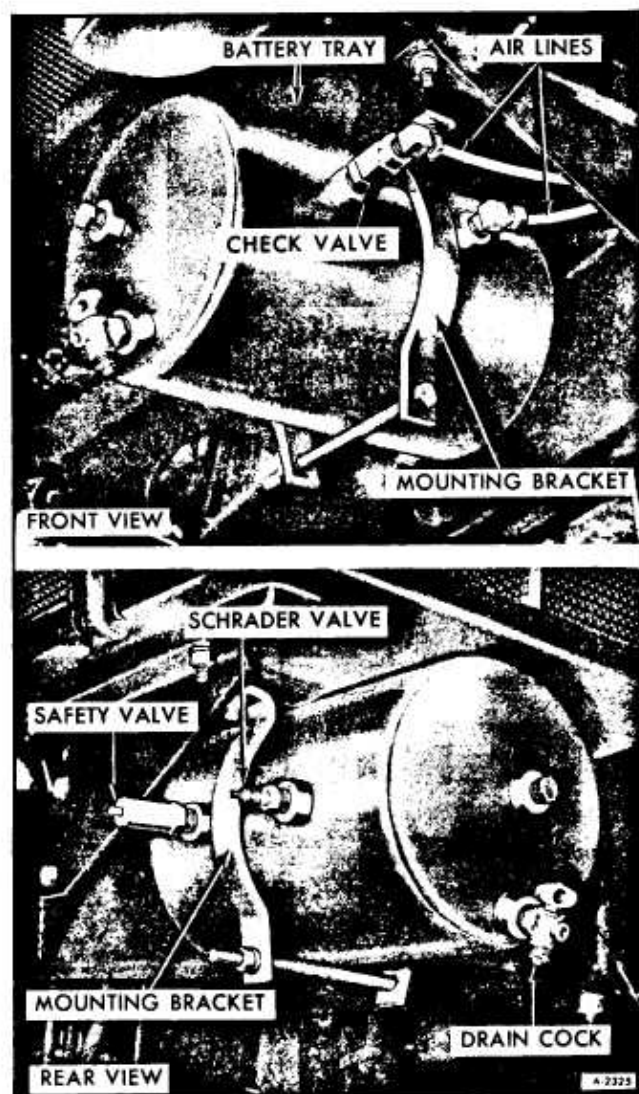

Figure 5—Air Reservoir

2. Remove the two air lines from the front of the reservoir.

3. Remove retaining nut and bolt from lower portion of bracket.

4. Remove reservoir.

5. Remove drain cock, safety valve, and schrader valve.

## HEIGHT CONTROL VALVE REMOVAL

Before disconnecting any height control valve air lines, securely support frame to prevent it from lowering as air is released from suspension. Exhaust air from air supply system by opening drain cock on air reservoir. After the above precautions have been taken, remove height control valve as follows:

1. Disconnect height control valve overtravel lever from valve link. Pull lever downward and hold several seconds to overcome time delay feature; This will release compressed air from bellows.

2. Referring to figure 6, disconnect air supply line and bellows air line from height control valve. Tape ends of lines to prevent foreign material from entering.

3. Remove two nuts attaching height control valve to wheel well and remove valve assembly.

## AIR BELLOWS REMOVAL

1. Support vehicle on jack stands.

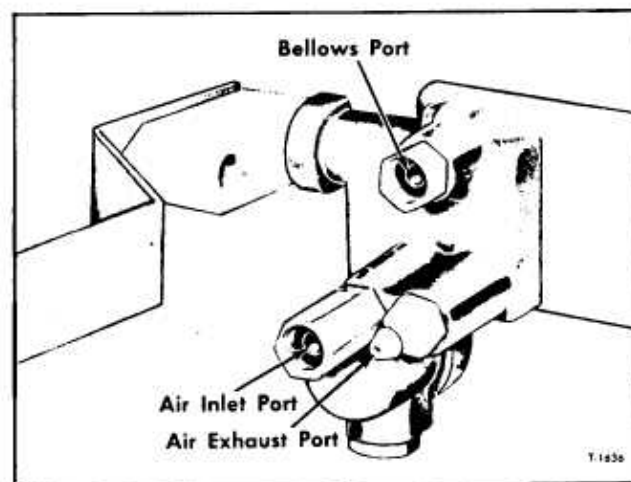

Figure 6—Height Control Valve Ports

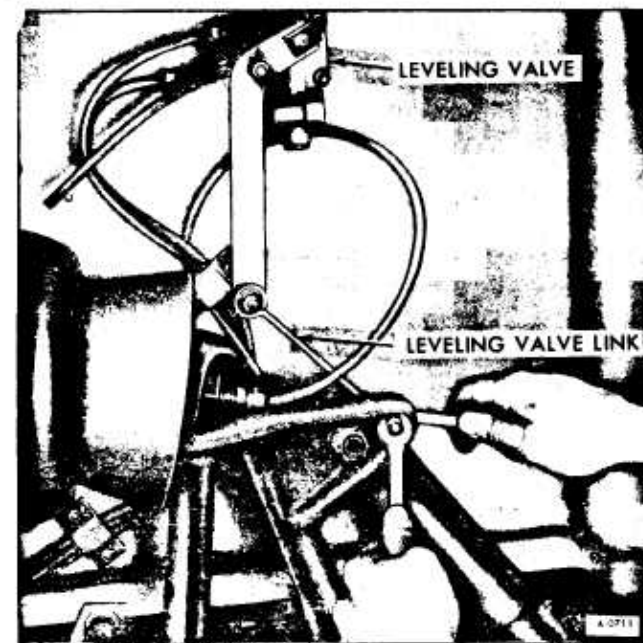

Figure 7—Disconnecting Height Control Valve Link

2. Referring to Figure 7, disconnect leveling valve link and move arm down to open exhaust valve and let air out of bellows.

3. Referring to Figure 8, disconnect air line to bellows.

4. Referring to Figure 9, remove retaining nuts and washers.

5. Remove air bellows from vehicle.

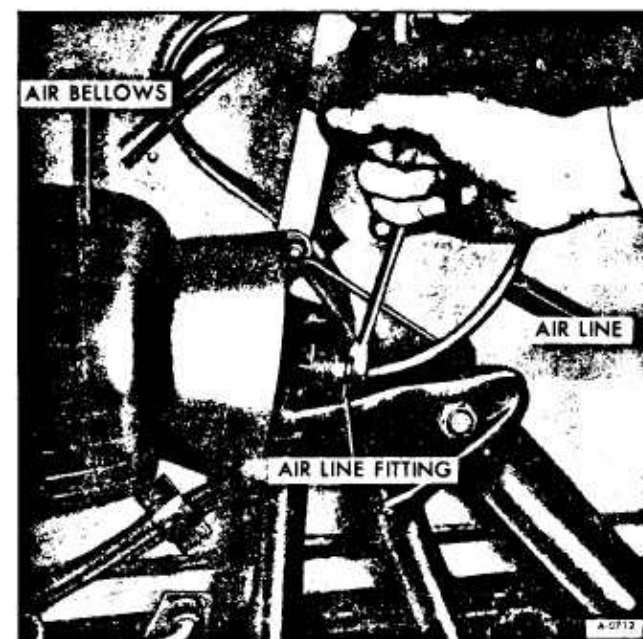

Figure 8—Disconnecting Bellows Air Line

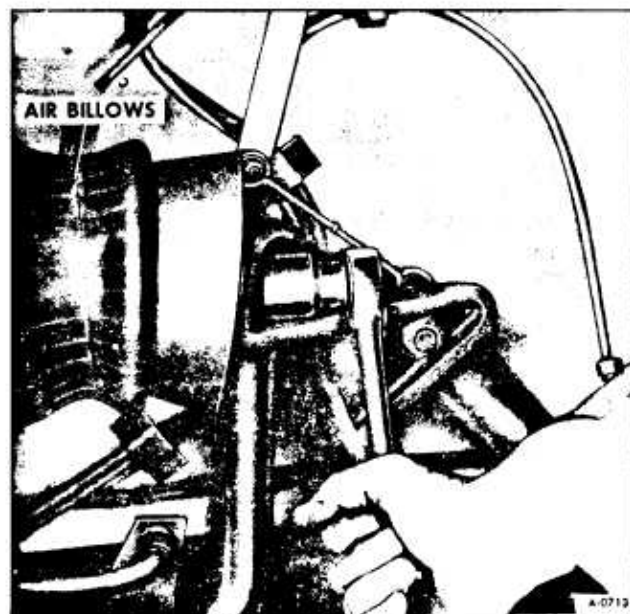

Figure 9—Removing Bellows Retaining Nut

## CONTROL ARM REMOVAL

1. Raise vehicle until rear wheels are off the floor.

2. Remove wheels.

3. Disconnect leveling valve link at control arm. Remove air from bellows by moving valve arm down. Disconnect air line at the bellows as shown in Figure 8.

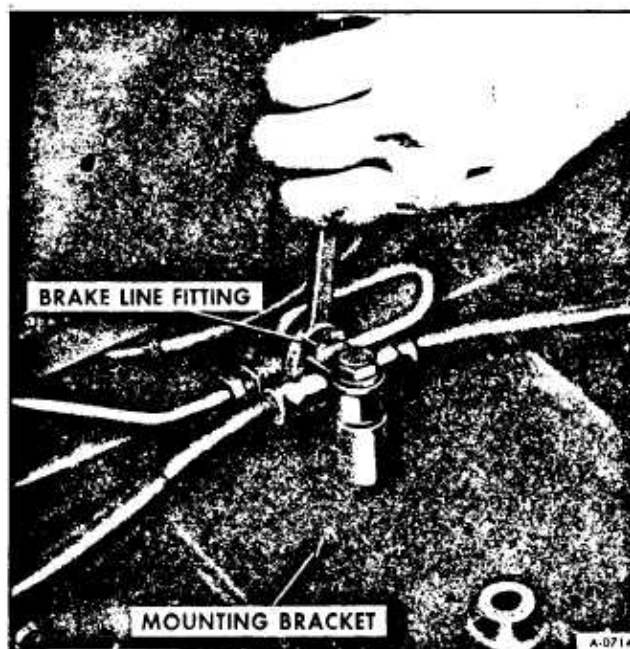

Figure 10—Disconnecting Brake Line

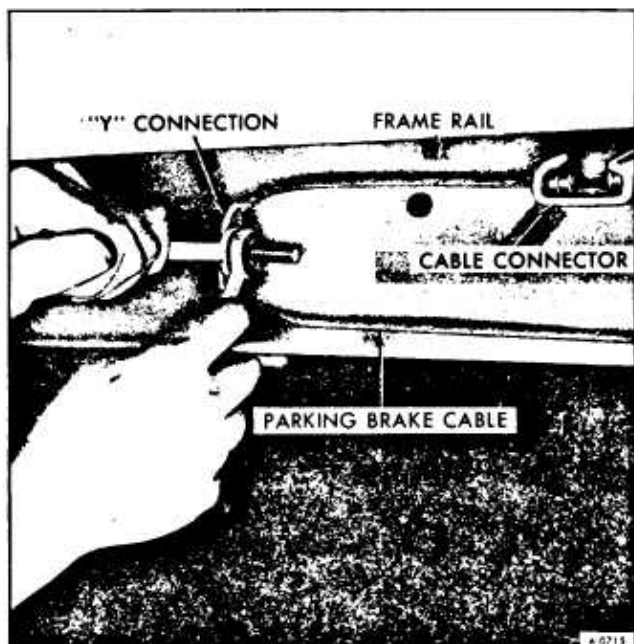

Figure 11—Disconnecting Parking Brake Cable

4. Remove bellows retaining nuts, located at either end of air bellows, as shown in Figure 9.

5. Disconnect shock absorbers from control arm mounting.

6. Referring to Figure 10, disconnect brake line at center mounting bracket and at each brake backing plate. Remove brake lines from control arms by unbolting all mounting points.

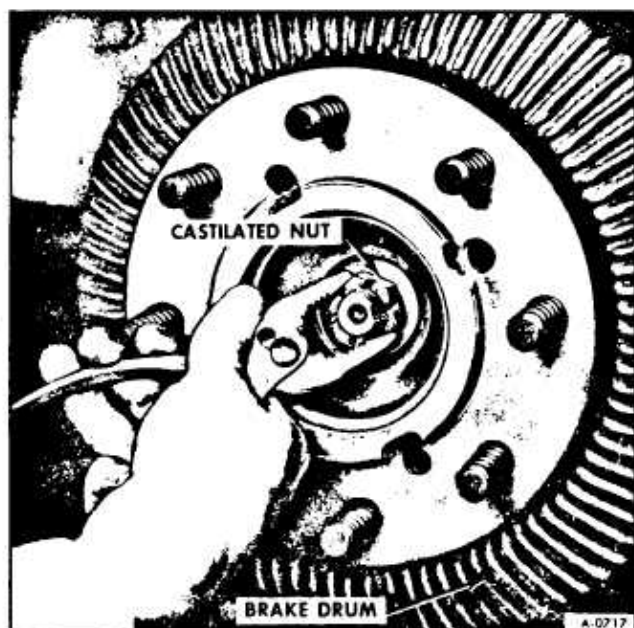

Figure 12—Dust Cap Removal



Figure 13—Castilated Nut Removal

7. Disconnect parking brake cable at "Y" connection as shown in Figure 11.

8. Remove brake drums, then—

A. Remove dust cap (figure 12)

B. Remove cotter pin castilated nut (figure 13).

C. Remove drum, hub, and bearings as a unit (figure 14).



Figure 14—Removing Hub and Drum

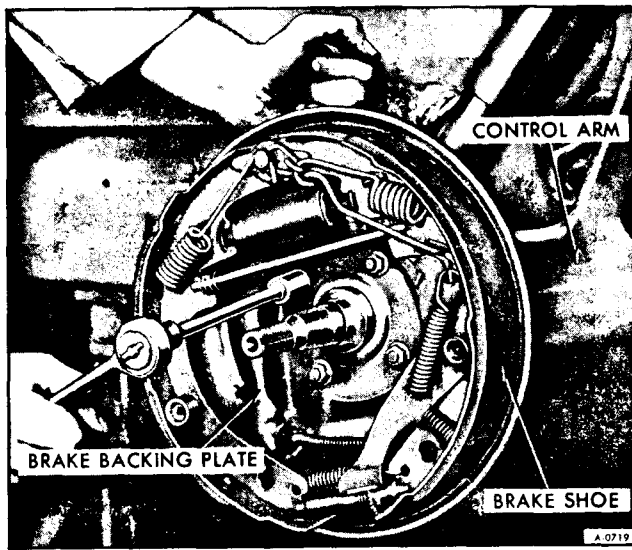

Figure 15—Removing Brake Backing Plate and Brake Shoe Assembly

9. Referring to Figure 15, remove four bolts and nuts retaining brake backing plate to control arm. Repeat procedure on opposite wheel.

10. Support mounting bracket with floor jack. Referring to Figure 16, remove two bolts holding mounting bracket to crossmember. Remove four bolts holding mounting bracket to frame rail.

11. Lower rear suspension unit to floor as shown in Figure 17.

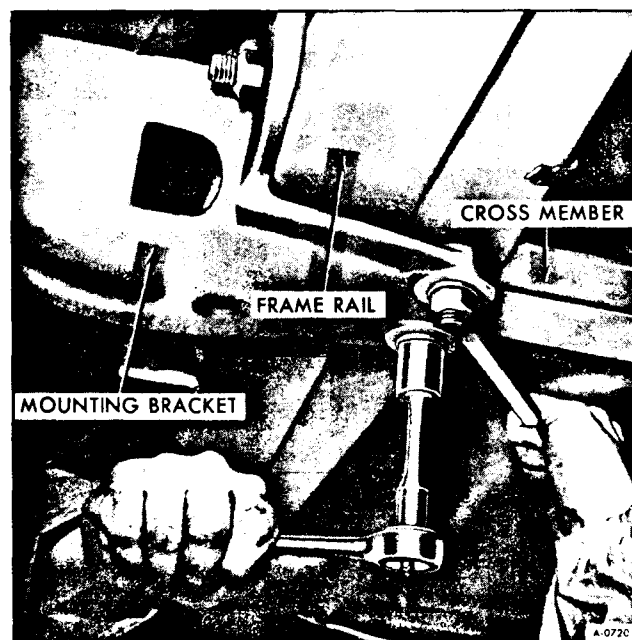

Figure 16—Removing Mounting Bracket Retaining Bolts

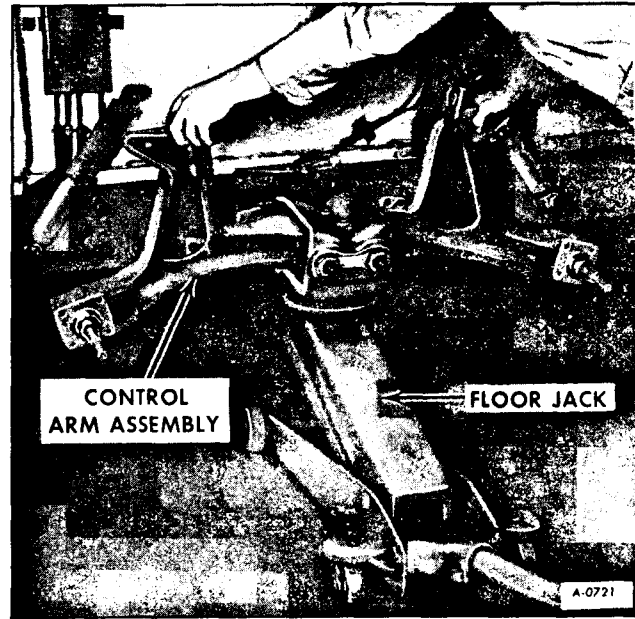

Figure 17—Lowering Control Arm Assembly from Vehicle

12. Referring to Figure 18, remove two nuts on mounting bracket. Remove Allen head retaining screws on back of mounting bracket as shown in Figure 19.

13. Press out control arm mounting pins, then remove control arms.

14. Press out spindles.

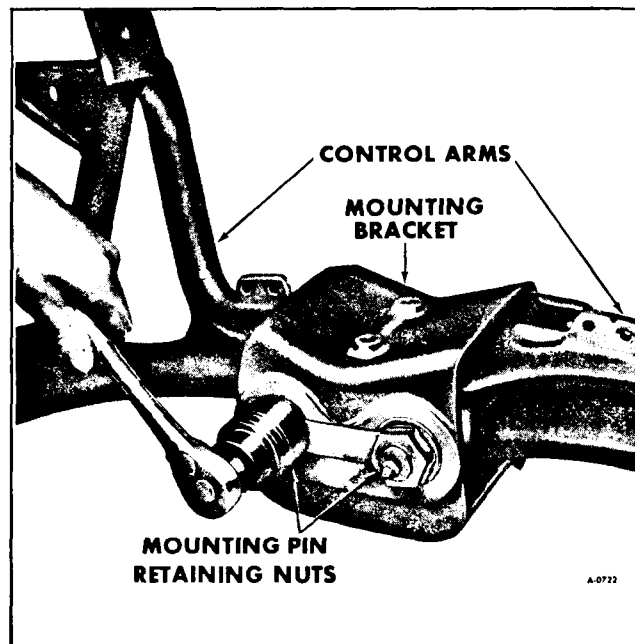

Figure 18—Removing Mounting Bracket Nuts

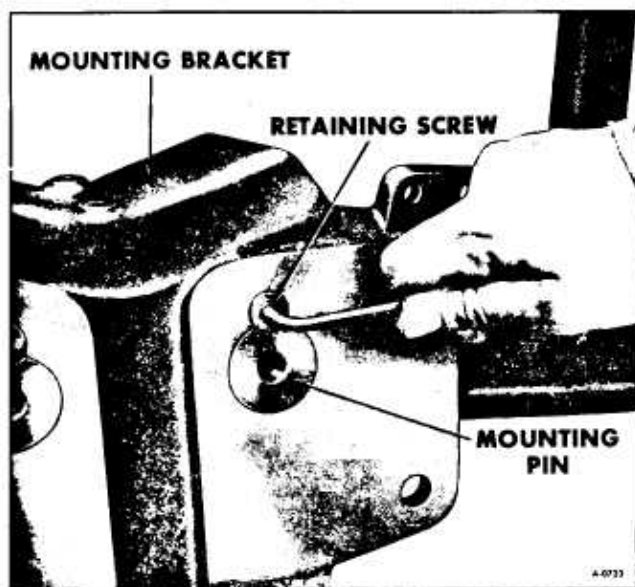

Figure 19—Removing Allen Head Retaining Screws

## SHOCK ABSORBER REMOVAL

Block control arms in an up position with a wooden block about one inch in thickness as shown in Figure 20.

Remove nut at top of shock absorber as shown in Figure 21, and remove shock from control arm. Remove nut from bottom of shock and remove shock from mounting bracket.

## POWER LEVEL VALVE REMOVAL

1. Bleed air from reservoir tank and place valve in lower position.

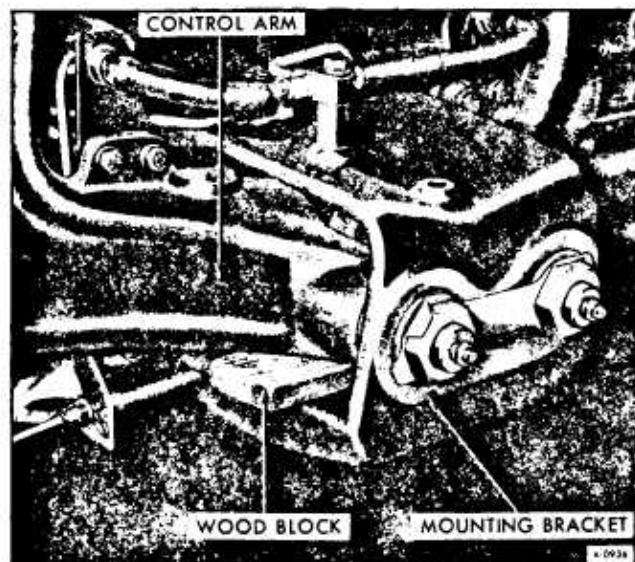

Figure 20—Positioning Wood Block Under Control Arm

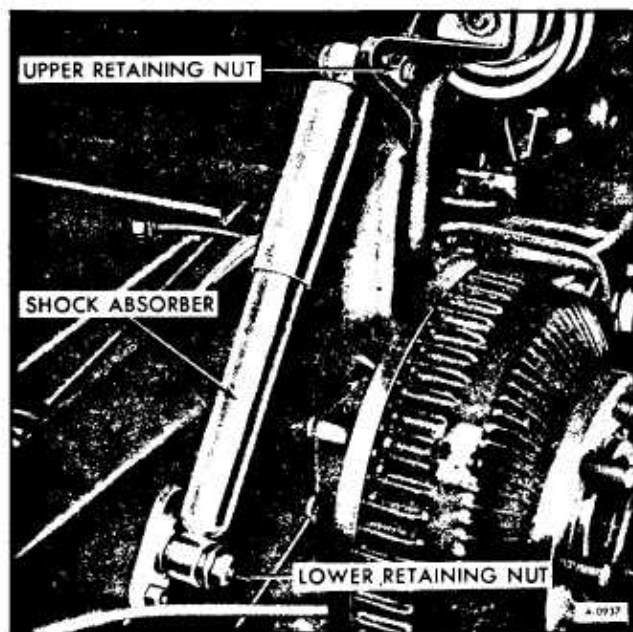

Figure 21—Removing Shock Absorber Retaining Nuts

2. Remove four screws on mounting panel.

3. Remove control knobs by removing Allen head screw in center of knobs (See figure 22).

4. Remove two screws holding each valve to mounting panel.

5. Disconnect three fitting from the back of each valve as shown in Figure 23 and remove valves.

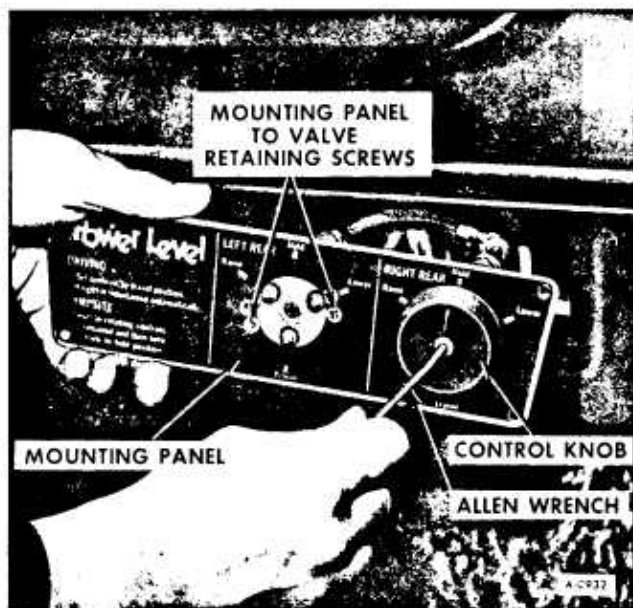

Figure 22—Removing Power Level Control Knobs and Panel



Figure 23—Removing Power Level Valve

## COMPRESSOR OVERHAUL

### PISTON RING REPLACEMENT

It is recommended that when the piston rings are replaced, the sleeve and expander rings be replaced also.

1. Remove compressor from vehicle.
2. Remove four screws from piston dome as shown in Figure 24. Remove piston dome and its gasket. Remove valve plate and its gasket.

3. Referring to Figure 25, remove piston sleeve.
4. Remove and replace piston rings and expanders.

**NOTE:** There is an expander located under each piston ring. The expander is an O-ring.

5. Install new piston sleeve.
6. Install valve plate and new gasket.
7. Install piston dome and new gasket, and retain in position with four screws.

### INTAKE VALVE REPLACEMENT

#### REMOVAL

1. Remove air compressor from vehicle.
2. Remove four screws from piston dome. Remove piston dome and its gasket, then remove valve plate and its gasket.
3. Remove piston sleeve.
4. Remove screw from valve on top of piston and remove valve.

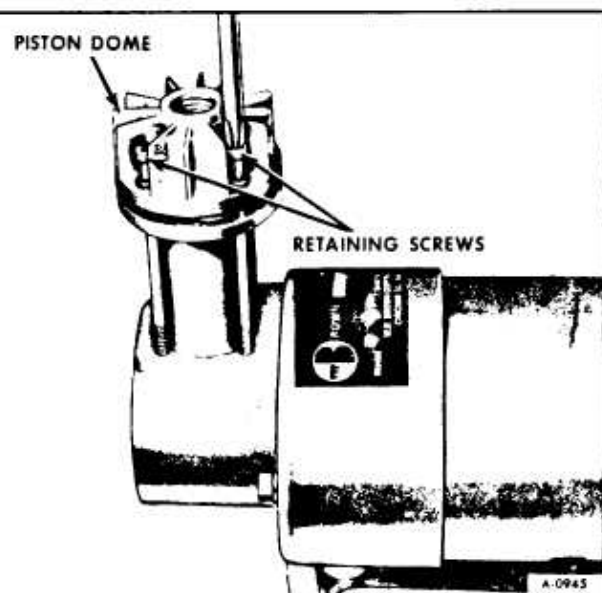

Figure 24—Removing Screws From Piston Dome

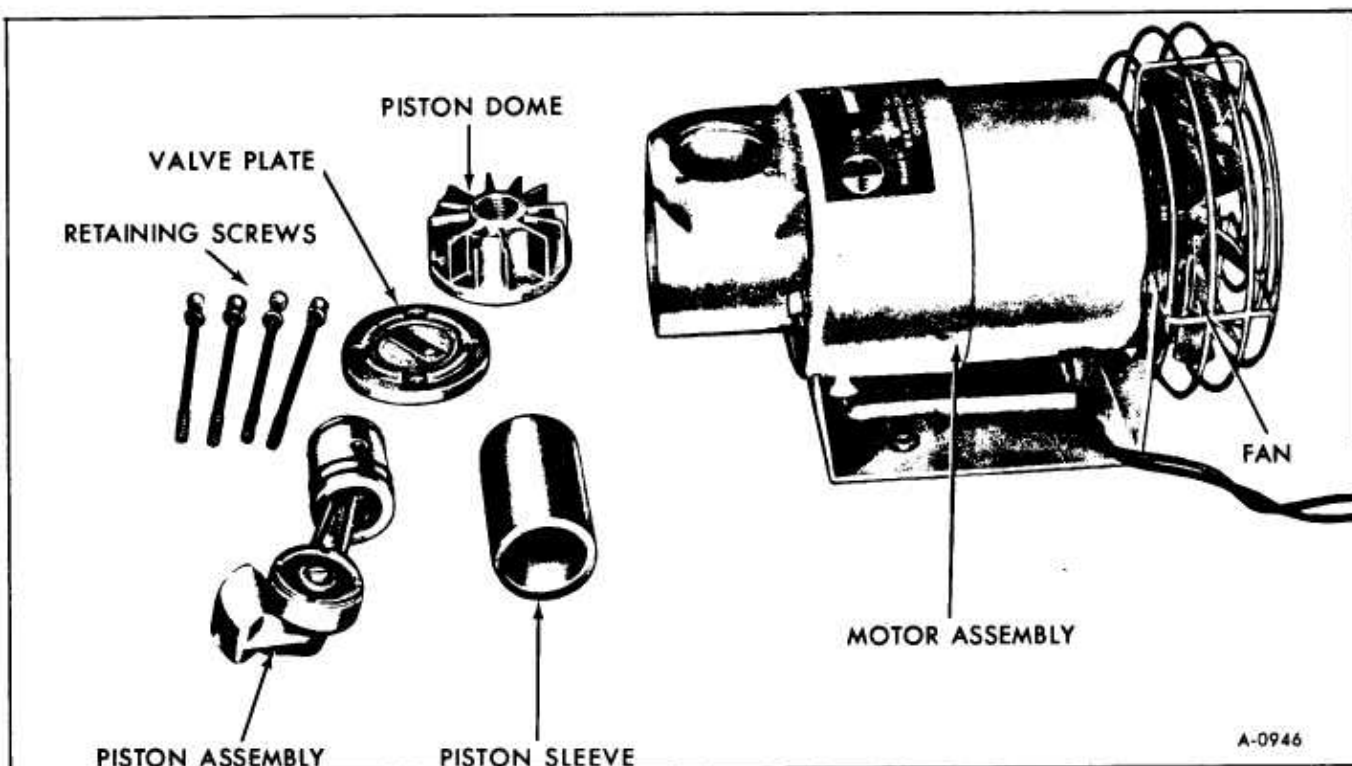

Figure 25-Compressor Components

## INSTALLATION

1. Install valve and screw retaining it on the piston.
2. Install piston sleeve.
3. Install valve plate and its gasket and install piston dome and its gasket. Install four screws in piston dome.

## EXHAUST VALVE REPLACEMENT REMOVAL

1. Remove air compressor from vehicle.
2. Remove four screws from piston dome. Remove piston dome and its gasket. Remove valve plate and its gasket.
3. Remove retaining screw from exhaust valve and remove valve as shown in Figure 26.
4. Remove "O" ring under valve.

## INSTALLATION

1. Install "O" ring by first applying a small amount of silicone rubber cement or equivalent in recess for "O" ring. Then set "O" ring in place.

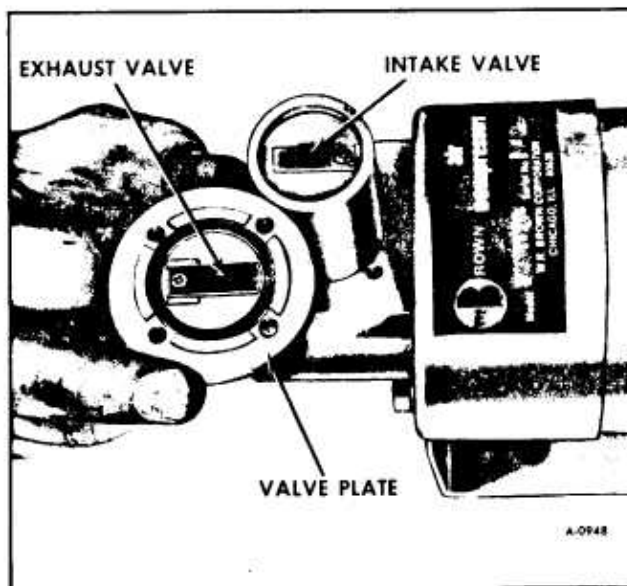

Figure 26-Removing Retaining Screw From Exhaust Valve

2. Install valve and retain in position on valve plate with screw.

3. Install valve plate and its gasket, and install piston dome and its gasket. Replace four screws in piston dome.

## PISTON REPLACEMENT

### REMOVAL

1. Remove air compressor from vehicle.

2. Remove four screws from piston dome. Remove piston dome and gasket. Remove valve plate and gasket.

3. Remove piston sleeve.

4. Remove air filter.

5. Rotate eccentric (figure 28) until piston is at the bottom of its stroke.

6. Referring to Figure 27, Loosen Allen head set screw which is at top of eccentric.

7. Remove eccentric from motor output shaft, and remove piston assembly through air filter opening as shown in Figure 28.

8. Remove piston rings and piston ring expanders.

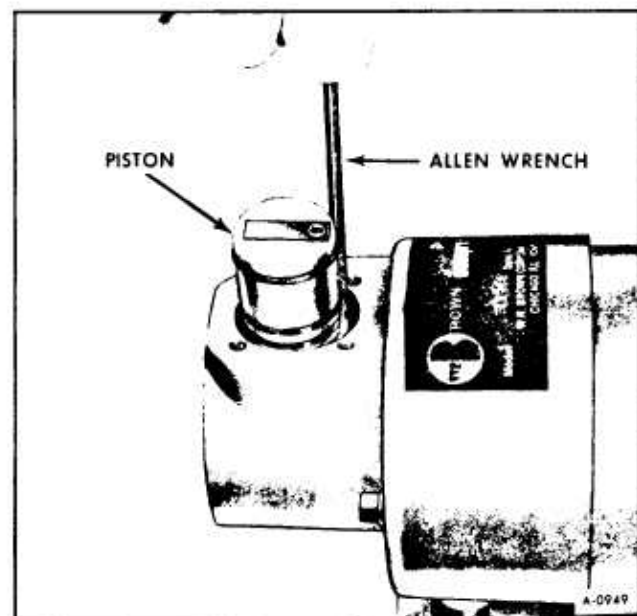

Figure 27—Loosening Allen Screw on Eccentric

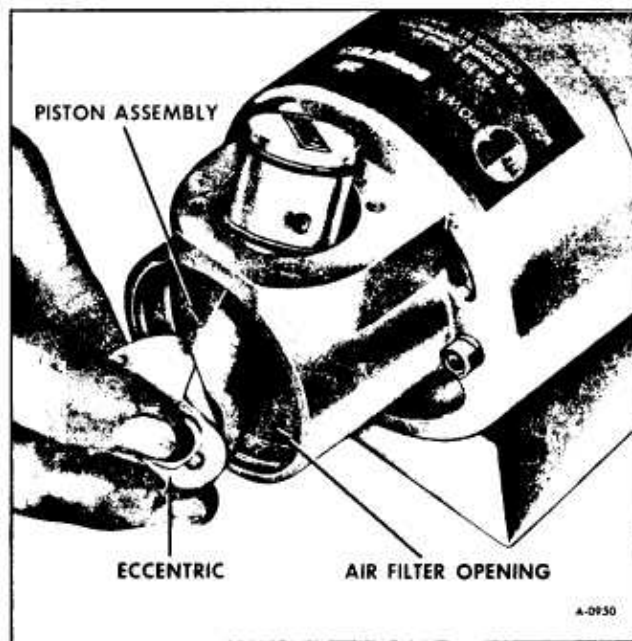

Figure 28—Removing Compressor Piston

### INSTALLATION

1. Install piston rings and piston ring expanders.

2. Place piston assembly in position with eccentric on motor output shaft. The eccentric must be positioned to contact the bearing on the motor.

3. Tighten Allen Head set screw on eccentric to at least 5 ft. lbs. torque.

4. Install piston sleeve.

5. Install valve plate and gasket, and install piston dome and gasket.

6. Install four screws in piston dome.

7. Install air filter.

## MOTOR REPLACEMENT

### REMOVAL

1. Remove air compressor from vehicle.

2. Remove four screws from piston dome. Remove piston dome and its gasket. Remove valve plate and its gasket.



3. Remove piston sleeve.
4. Remove air filter.
5. Rotate eccentric until it is at the bottom of its stroke.
6. Referring to Figure 27, loosen Allen Head set screw which is at top of eccentric.
7. Remove eccentric from motor output shaft, and remove piston assembly through air filter opening as shown in Figure 28.
8. Remove two nuts holding on fan blade guard and remove the guard.
9. Loosen Allen Head set screw in fan hub, and remove fan blades.

## INSTALLATION

1. Install fan blades and tighten Allen Head set screw.
2. Install fan blade guard.
3. Place piston assembly in position with eccentric on motor output shaft. The eccentric must be positioned to contact the bearing on the motor.

4. Tighten Allen Head set screw, on eccentric to at least 5 ft. lbs. torque.
5. Install piston sleeve.
6. Install valve plate and its gasket, and install piston dome and its gasket.
7. Install four screws in piston dome.
8. Install air filter.
9. Install compressor in vehicle.

## FAN REPLACEMENT

### REMOVAL

1. Remove two nuts from fan guard and remove guard.
2. Loosen Allen Head set screw at center of fan hub. Remove fan from motor shaft.

### INSTALLATION

1. Install fan on motor shaft, tighten Allen Head set screw.
2. Install fan guard and install two nuts.

## HEIGHT CONTROL VALVE OVERHAUL

**IMPORTANT:** Height control valve-overhaul will be limited as shown in Figure 29. If repair procedures require replacement of valve body be sure to install new "O" rings and screens, as shown in Figure 29.

## HEIGHT CONTROL VALVE ADJUSTMENTS

### GENERAL

To properly adjust the height control valve, it is **ESSENTIAL** that the following procedures be followed and in the sequence mentioned:

Three main adjustments are required:

1. Overtravel lever center position adjustment.

2. Air intake and exhaust valve lever gap adjustments.
3. Time delay check.

**NOTE:** The height control valve assembly must be removed from vehicle to make the above adjustments.

Instructions for checking the ride height dimensions are explained under "Ride Height Check and Adjustment."

**IMPORTANT:** The silicone fluid should be drained from control valve assembly before making the first two adjustments.

### OVERTRAVEL LEVER CENTER POSITION ADJUSTMENT

1. Clean exterior of control valve assembly.

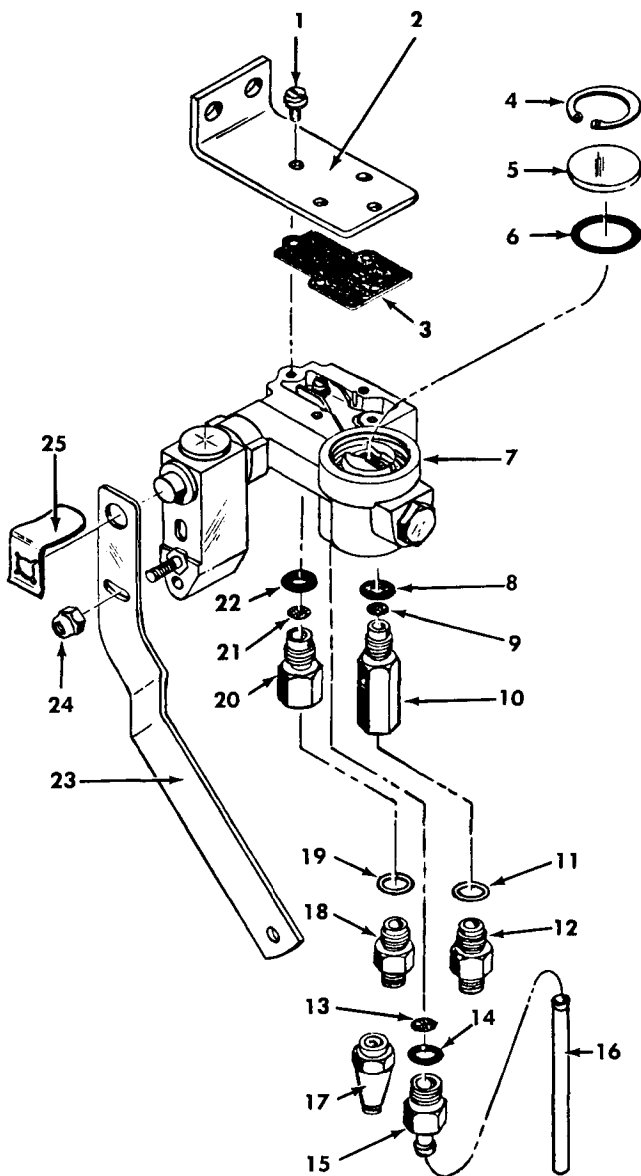

- 1 Screw, Cover Plate & Mounting Bracket
- 2 Cover Plate and Mounting Bracket
- 3 Gasket, Cover Plate & Mounting Bracket
- 4 Retaining Ring
- 5 Retainer, Delay Piston
- 6 "O" Ring
- 7 Valve Body
- 8 "O" Ring
- 9 Screen
- 10 Intake Valve Adapter Assembly
- 11 Gasket
- 12 Adapter
- 13 Screen
- 14 "O" Ring
- 15 Check Valve - Exhaust
- 16 Exhaust Tube
- 17 Tube Fitting
- 18 Adapter
- 19 Gasket
- 20 Adapter Assembly
- 21 Screen
- 22 "O" Ring
- 23 Arm
- 24 Nut, Arm Retaining
- 25 Fastener, Plug Retaining

A-1302

Figure 29-Height Control Valve

2. Remove cover and rubber O-ring from valve assembly, then drain off the Silicone fluid.

3. Remove exhaust fitting (15, figure 29) and exhaust screen (13, figure 29) from control valve.

4. Referring to Figure 31, scribe a line 1-3/8 inch from plug end of overtravel lever control body.

5. Place control valve assembly in vise as shown in Figure 33.

6. If vacuum source is available, attach supply hose to valve exhaust port (figure 30) using Sun

Tester fitting #115-3 or equivalent. Do not apply vacuum at this time.

7. Attach air pressure supply hose to air inlet port (figure 30). Do not apply pressure at this time.

8. Locate dial indicator in position as shown in Figure 31. Move overtravel lever to full air exhaust position - TOP OF DELAY PISTON FLUSH WITH TOP OF BORE - without overtraveling (position "C," figure 32). Relocate indicator push rod to just contact 1-3/8-inch mark on control body and reset indicator dial to zero (0) at this point (position "C", figure 32).

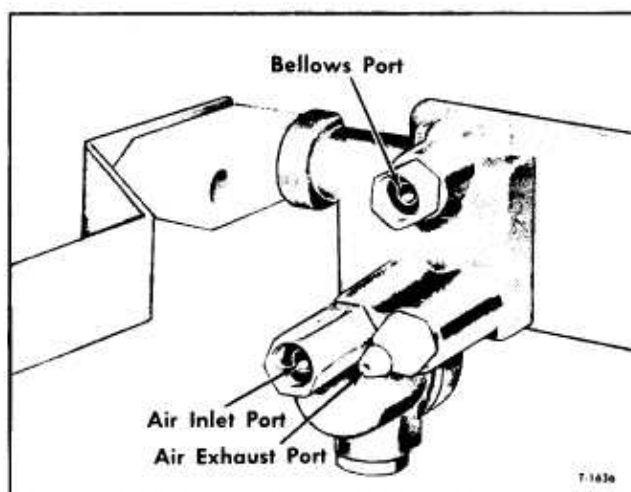

Figure 30—Height Control Valve Port Identification

9. Move overtravel lever to full air intake position without overtraveling (position "A", figure 32) (delay piston at bottom of bore). Take indicator reading which may vary from 0.160" to 0.190".

10. Repeat Steps 8 and 9 above to recheck this reading.

11. Divide the total travel dimension by two (example:  $0.170" \div 2 = 0.085"$ ), then move overtravel lever back this amount (0.085") to the center (position "B," figure 32).

**IMPORTANT:** Without disturbing lever center position, reset indicator dial to zero (0), which actually is 0.100" on indicator of type registering

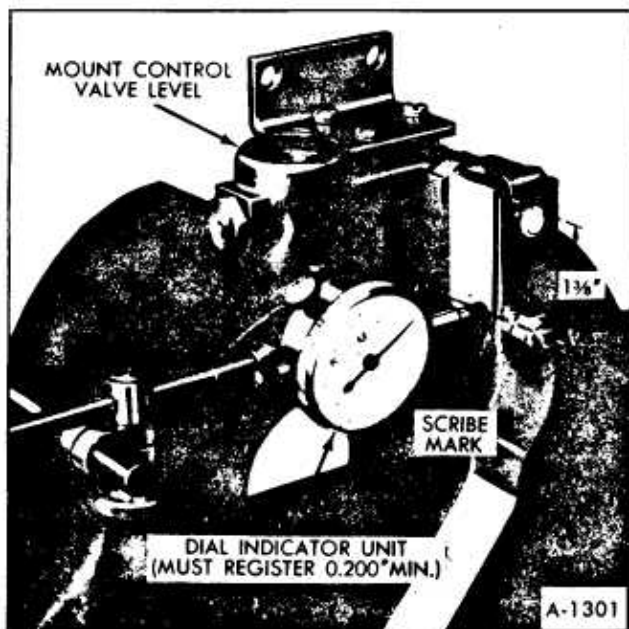

Figure 31—Dial Indicator Properly Installed

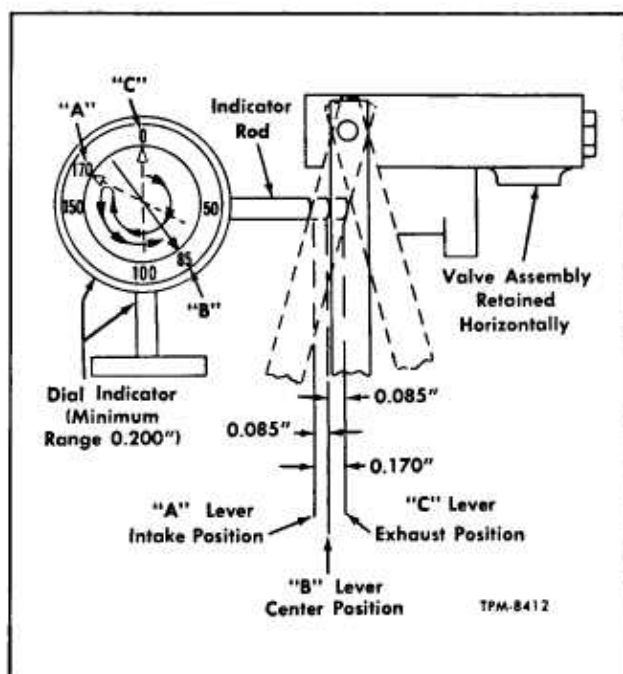

Figure 32—Locating Valve Overtravel Lever Center Position

0.100" for each revolution of indicator needle, then proceed with valve lever gap adjustments following:

## AIR INTAKE AND EXHAUST VALVE LEVER ADJUSTMENTS

**IMPORTANT:** Before making these adjustments the overtravel lever must be centered as explained previously.

Two methods of adjustment are available:

### 1. Using Both Air Pressure and Vacuum.

**NOTE:** If vacuum source is available, this method will take less time to perform adjustment. Vacuum source is used to make the exhaust valve lever gap check only.

### 2. Using Air Pressure Only.

**NOTE:** When this method is used, it will take longer to perform adjustments as the valve cover must be in place each time air pressure is applied and then removed to permit adjustment of exhaust valve lever.

## Method Using Air Pressure and Vacuum

1. If air supply and vacuum lines were not connected to control valve assembly as directed previously when centering valve overtravel lever, connect lines.

2. Apply air pressure and regulate it to 80 to 110 psi. Apply vacuum and regulate it at approximately 15 inches.

3. Move overtravel lever fore and aft several times and then back to true center position.

4. Starting at true center position, slowly move lever to where air intake valve just begins to open. Listen for escaping air. Note reading on dial at this point. Reading should be 0.025" to 0.027" from lever center position. Bend lever to correct setting. Refer to Figure 33.

5. Return overtravel lever to center position. Slowly move lever to exhaust side and at same time note the vacuum gauge reading. When vacuum just begins to fall off, the exhaust valve has opened. Valve should open when overtravel lever is moved 0.035" to 0.037" from center position. On both front and rear control valves, bend lever to correct setting. Refer to Figure 33.

6. Recheck intake and exhaust valve lever gaps, then proceed with "TIME DELAY CHECK" explained later.

## Method Using Air Pressure Only

**NOTE:** This method may be performed when a vacuum source is not available.

1. Connect air supply hose (80 to 110 psi) to air inlet port (figure 30).

2. To adjust air intake valve lever gap:

a. Move the overtravel lever slowly from true center position to point where intake valve just begins to open. Listen for escaping air. Note reading to dial at this point which should register 0.025" to 0.027".

b. Bend lever to correct setting. Refer to Figure 33.

3. To adjust air exhaust valve lever gap:

a. Install valve cover on the valve using the rubber gasket and four attaching screws.

b. Being careful not to disturb indicator setting, disconnect air supply from the air inlet port and connect it to the bellows port (figure 30).

c. Move overtravel lever slowly to open exhaust port while observing the indicator dial. Air should start to escape from exhaust port when indicator registers 0.035" to 0.037". If adjustment is necessary, shut off air pressure supply and remove valve cover. Bend lever to correct setting, then install cover and recheck valve opening dimension.

d. Recheck valve lever gaps, then proceed with "TIME DELAY CHECK" following:

## TIME DELAY CHECK

### Preliminary Procedures

After the valve lever gaps have been properly adjusted, the time delay check must be performed. A four to eighteen seconds delay from the closing of one valve to the opening of the other is recommended. Also, valves should close from full-open position within four seconds.

1. Pour 5.5 cc  $\pm$  0.25 cc of Silicone fluid (3,000 Centistokes viscosity at 25°C.) into delay piston bore. With valve body tilted slightly, as shown in Figure 34, carefully operate overtravel lever fore and aft to vent air from fluid. When all air has been expelled from piston pin cavity, check fluid level (figure 35).

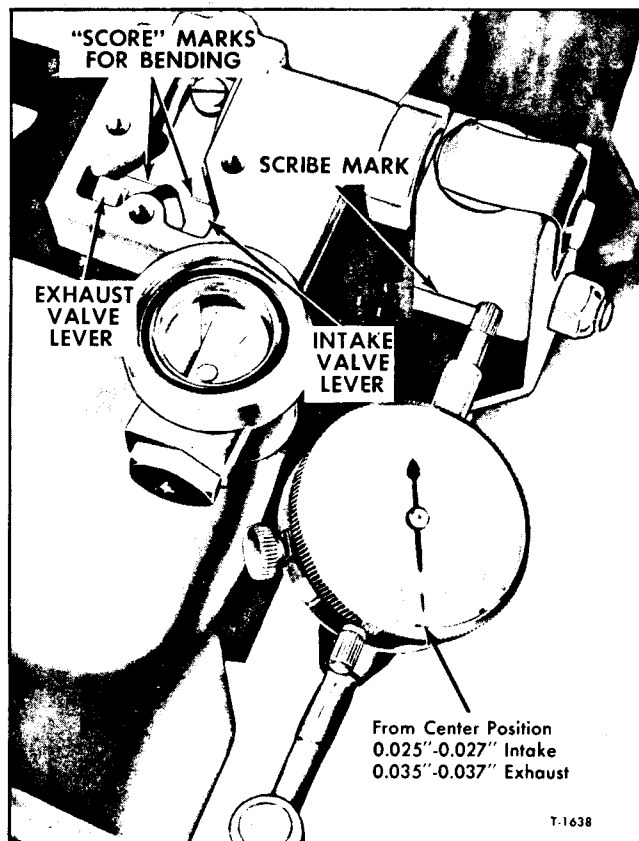

Figure 33—Method of Adjusting Air Valve Lever Gaps

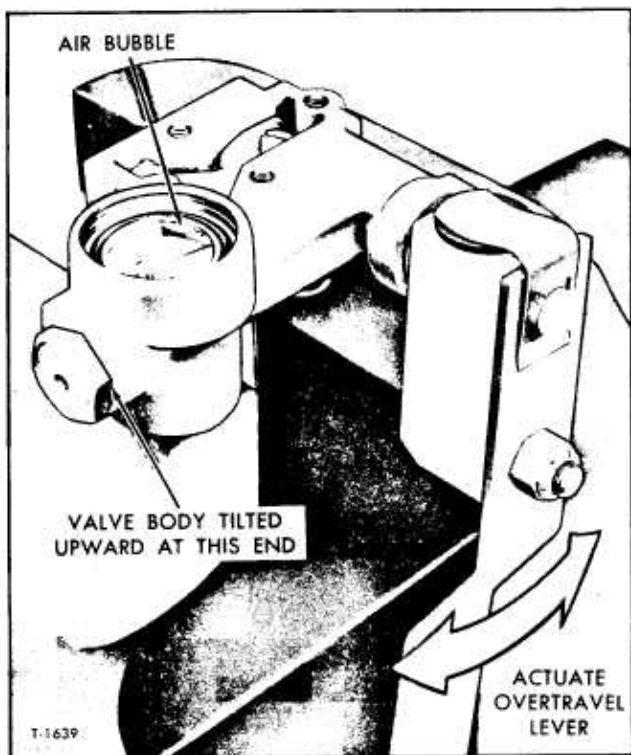

Figure 34-Venting Air From Silicone Fluid

**IMPORTANT:** With valve assembly level, take measurement from center of bore only. Add or remove fluid to bring fluid to dimension shown in Figure 35. An eyedropper will serve for this purpose.

2. Place new delay piston cover O-ring in groove of valve body. Install cover with retainer.

3. Place valve assembly vertically in holding vise (figure 36).

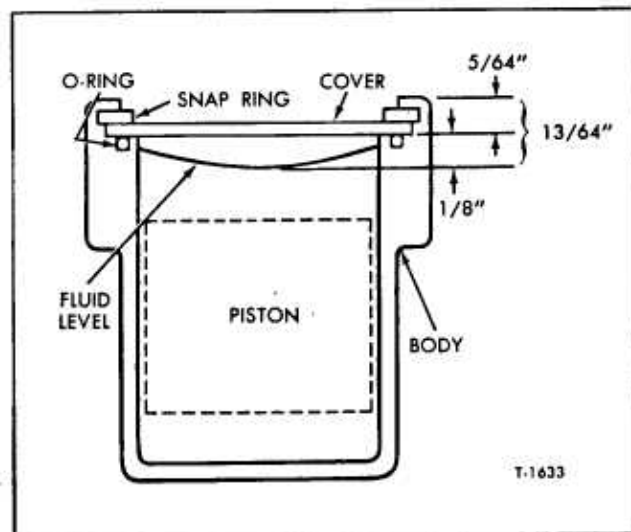

Figure 35-Silicone Fluid Level

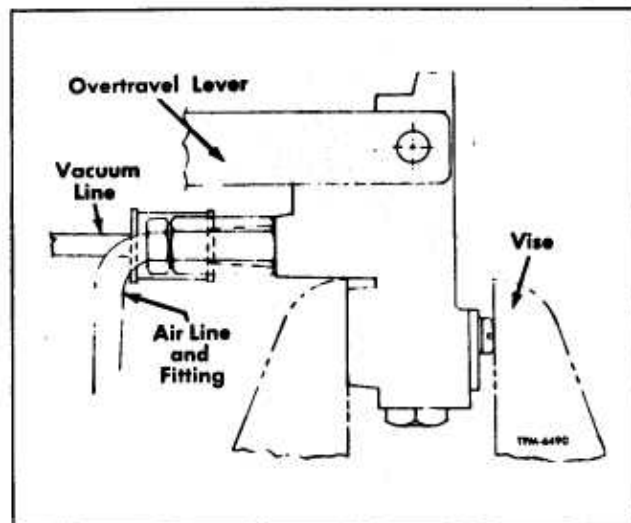

Figure 36-Valve Positioned for Time Delay Check

4. Cycle arm up and down for approximately one minute.

### Air Inlet Time Delay Check

1. Connect air pressure supply hose to valve air inlet port (figure 30).

2. Move overtravel lever upward (quickly) approximately two inches and simultaneously start counting the number of seconds before air starts to escape from bellows port. A delay of four to eighteen seconds should exist. Repeat this check.

### Air Exhaust Time Delay Check

To time the delay for exhaust, two methods can be used; one using vacuum source and one using air pressure.

#### 1. Method Using Vacuum

a. Connect vacuum hose to air exhaust port (figure 30). Adjust vacuum to 15 inches.

b. Move the overtravel lever downward (quickly) approximately two inches and simultaneously start counting the number of seconds before the vacuum gauge starts to drop off. A delay of ten to fifty seconds should exist. Repeat this check.

#### 2. Method Using Air Pressure

a. Install valve cover with rubber gasket on valve assembly.

b. Connect air pressure supply hose to bellows port (figure 30).

c. Move overtravel lever downward (quickly) approximately two inches and simultaneously start counting the seconds before air starts to escape from the exhaust port. A delay of ten to fifty seconds should exist.

**IMPORTANT:** A time delay over fifty seconds could mean too large a valve lever gap adjustment and a time delay under ten seconds would mean too small a valve lever gap adjustment. If the time delay is not within 10 to 50 seconds, first recheck the fluid level. If fluid level is satis-

factory, the valve lever gap adjustment must be repeated, step by step.

**NOTE:** (Refer to figure 29.) After obtaining proper valve adjustments, install valve cover using new rubber gasket (3). Install new screen (21), in bellows port, then using new O-ring (22), install outlet adapter (20) into bellows port. If screen (13) was removed from exhaust port, install new screen and exhaust fitting (15).

**NOTE:** Place tape over ends of air line ports until such time valve assembly is installed on the vehicle.

## COMPONENT INSTALLATION

### AIR COMPRESSOR AND PRESSURE SWITCH INSTALLATION

1. Referring to Figure 2, install pressure switch by attaching to fitting at mounting bracket.
2. Install compressor to mounting bracket using four nuts and bolts.
3. Connect motor lead to pressure switch. Connect ground wire to mounting bracket.
4. Place compressor switch assembly in position and fasten with three bolts to vertical bracket.
5. Install two bolts on horizontal bracket.
6. Connect pressure-switch assembly wiring.
7. Connect air line to compressor-switch assembly.
8. Run compressor to pressurize system.

### AIR RESERVOIR INSTALLATION

1. Referring to Figure 5, install drain cock, safety valve, and schrader valve.
2. Install reservoir.
3. Install retaining bolt and nut and tighten securely.
4. Connect two air lines to tank.

5. Run compressor to pressurize system and check for leaks.

### HEIGHT CONTROL VALVE INSTALLATION

Before installing height control valve assembly, see that air line fittings are clean and undamaged.

**NOTE: DO NOT USE SEALING COMPOUND ON THREADS.** Sealer is unnecessary, and if used, may cause valves to stick. Absolute cleanliness is essential when installing height control valves. Dirt and sealing compound must be kept out of valves. Even minute particles of foreign matter may become lodged in valve cores or flapper valves and may seriously affect operation of suspension system.

1. Position height control valve at mounting studs on wheelwell. Attach with two nuts and tighten to 80-120 in.-lbs. torque.
2. Connect air supply line to intake adapter, connect bellows air line to outlet adapter. Tighten air line connector nuts firmly.

3. Connect height control valve overtravel lever to valve link and tighten to 60-90 ft.-lbs. Build up air pressure in system and test for leaks. Check ride height dimension and adjust if necessary as described later in this section.

### AIR BELLOWS INSTALLATION

1. Place air bellows piston on floor, cone section pointing up. Place air bellows in piston, with open end pointing up.

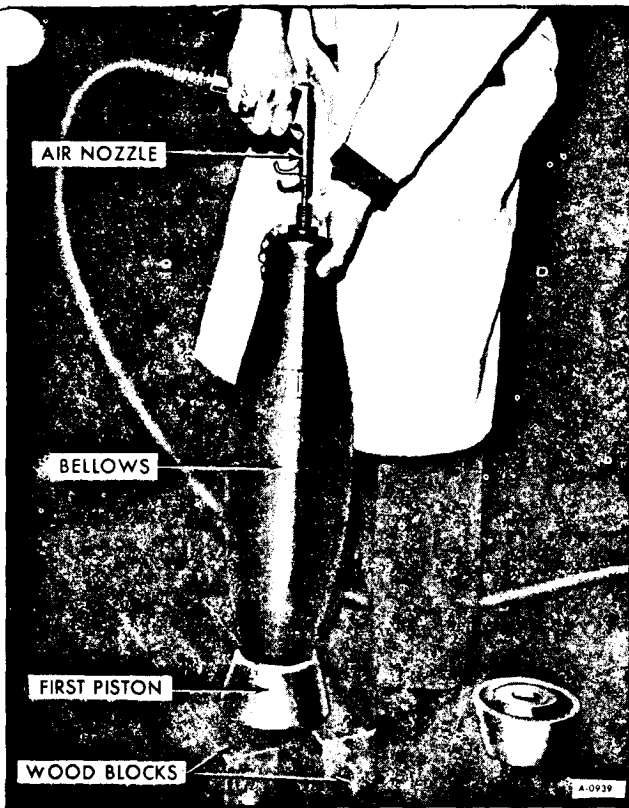

Figure 37—Applying Shop Air to Air Bellows



Figure 38—Installing Second Piston on Air Bellows

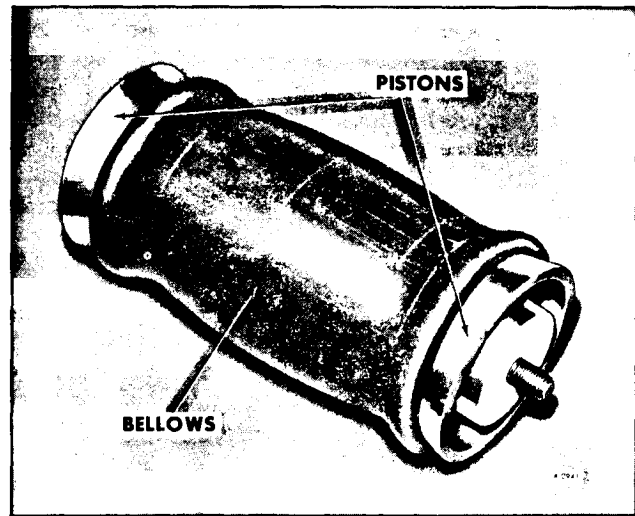

Figure 39—Air Bellows Assembly

2. Referring to Figure 37, apply shop air to bellows while pushing down on bellows, release air pressure. The bellows will fold over the piston.

3. Place second piston over top of bellows and apply shop air again as shown in Figure 38. Push down on bellows and release air pressure. Bellows will fold over piston. Completed bellows assembly should appear as shown in Figure 39.

4. Raise rear wheels to bring top of control arms close together. Block control arm as shown in Figure 20. Place air bellows in position. Install star washers and lock nuts. Torque lock nuts to 50-60 ft.-lbs.

5. Connect air line and move height control valve arm up to apply air to bag.

6. Connect leveling valve link. Lower vehicle to ground and allow leveling valve to bring it to proper ride height.

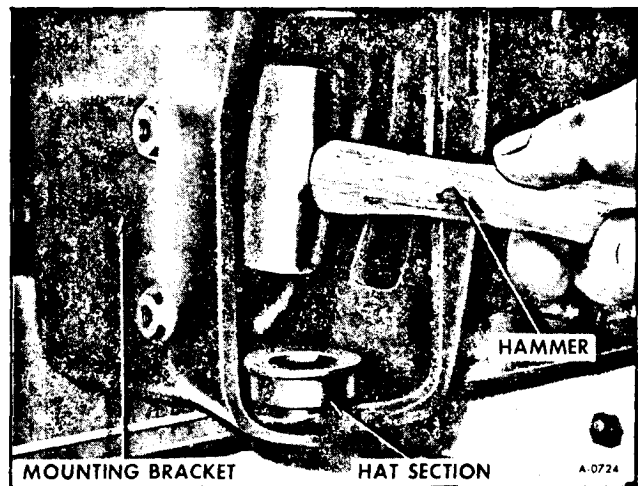

Figure 40—Repositioning Hat Section

## CONTROL ARM INSTALLATION

1. With the aid of hammer as shown in Figure 40, tap back hat section spacers (2) in mounting bracket to provide more room for control arms in bracket.
2. Place control arm in position in mounting bracket. Position thrust pack journal bearing between control arm and mounting bracket. (See figure 41).
3. Press bracket pins into proper position.
4. Place nut lock in position and install control arm lock nuts.
5. Tighten control arm lock nuts until hat section spacers are firmly seated, then back off nut until control arm moves freely, and retorque nuts to 15-20 lbs.-ft. Bend ears on nut lock over nut. (See figure 18).
6. Press in spindles.
7. Referring to Figure 17, position unit on vehicle and install four bolts from mounting bracket to frame rail. Install two (2) bolts from mounting bracket to frame crossmember (see figure 16).
8. Referring to Figure 16, install brake backing plate by installing four bolts and nuts retaining plate to control arm.
9. Referring to Figure 14, install brake drums and hubs on spindle. Tighten castilated nut (figure 13) to 25-30 ft.-lbs., back nut off one half turn and then finger tighten until cotter pin can be installed.

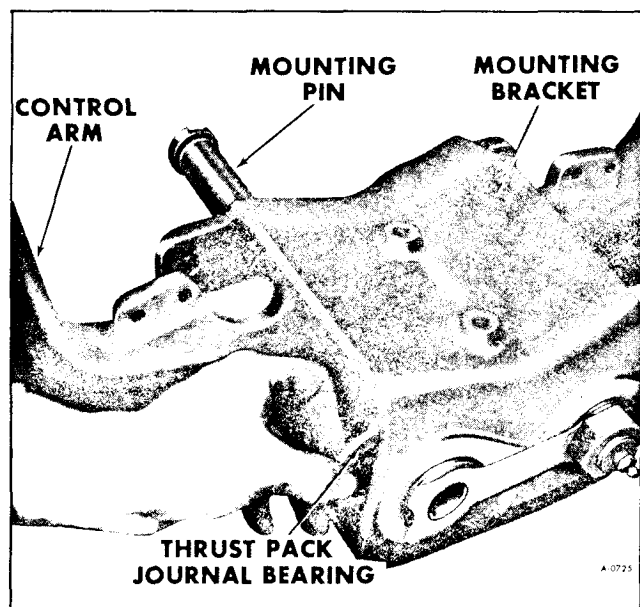

Figure 41—Installing Thrust Bearings

10. Install shock absorbers to control arms.
11. Install brake lines. Connect all mounting brackets and connect lines at brake backing plates and at control arm mounting bracket.
12. Referring to Figure 9, install air bellows.
13. Referring to Figure 7, connect leveling valve link and torque nut to 60-90 lbs.-ft.
14. Apply air to bellows.
15. Install tire and wheels.
16. Lower vehicle to floor and allow leveling valve to bring vehicle to ride height.
17. Bleed brakes as described in Section 5 Brakes.

## SHOCK ABSORBER INSTALLATION

Block control arms in an up position with a wooden block about one inch in thickness as shown in Figure 20. Install top of shock in upper control arm and secure with nut. Install bottom of shock on mounting bracket on frame rail, and secure with nut.

## POWER LEVEL VALVE INSTALLATION

1. Wrap threads on air line fittings with teflon tape.
2. Install lines to back of valves, referring to figure 44. On the right valve, red line goes to the port marked "MAN.," blue line goes to the port marked "OUT," and yellow lines goes to the port marked "AUTO." On left valve, red line goes to the port marked "MAN.," gray line goes to the port marked "OUT," purple line goes to the port marked "AUTO."
3. Install two (2) screws holding valve to mounting panel (see figure 22).
4. Install four (4) screw holding mounting panel to dash.
5. Install control knob using Allen Head screw in center of knob.
6. Close drain cock on air reservoir, place control



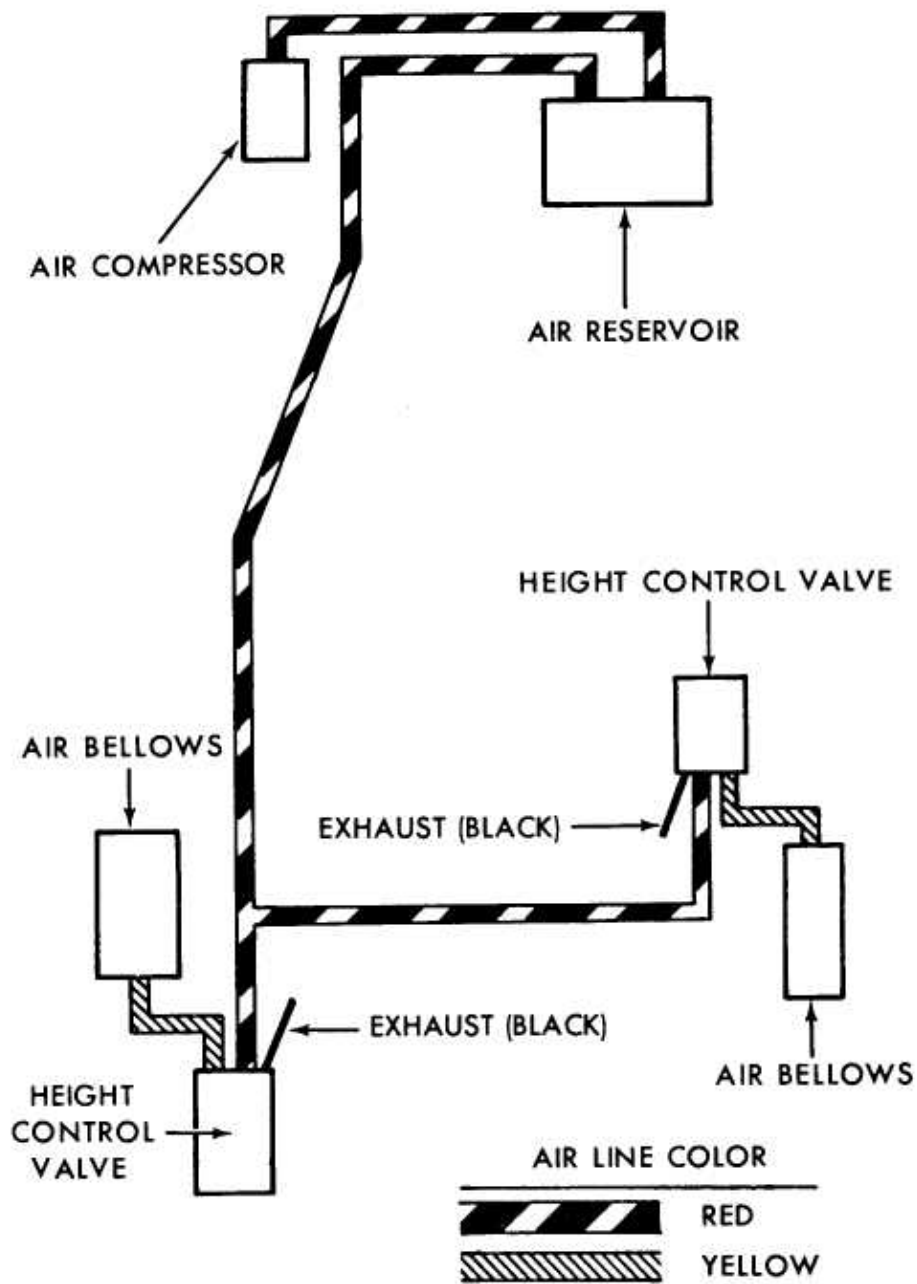

A-0942

@2-9.00 Neg. A-0942

Figure 42-Standard Rear Suspension Schematic

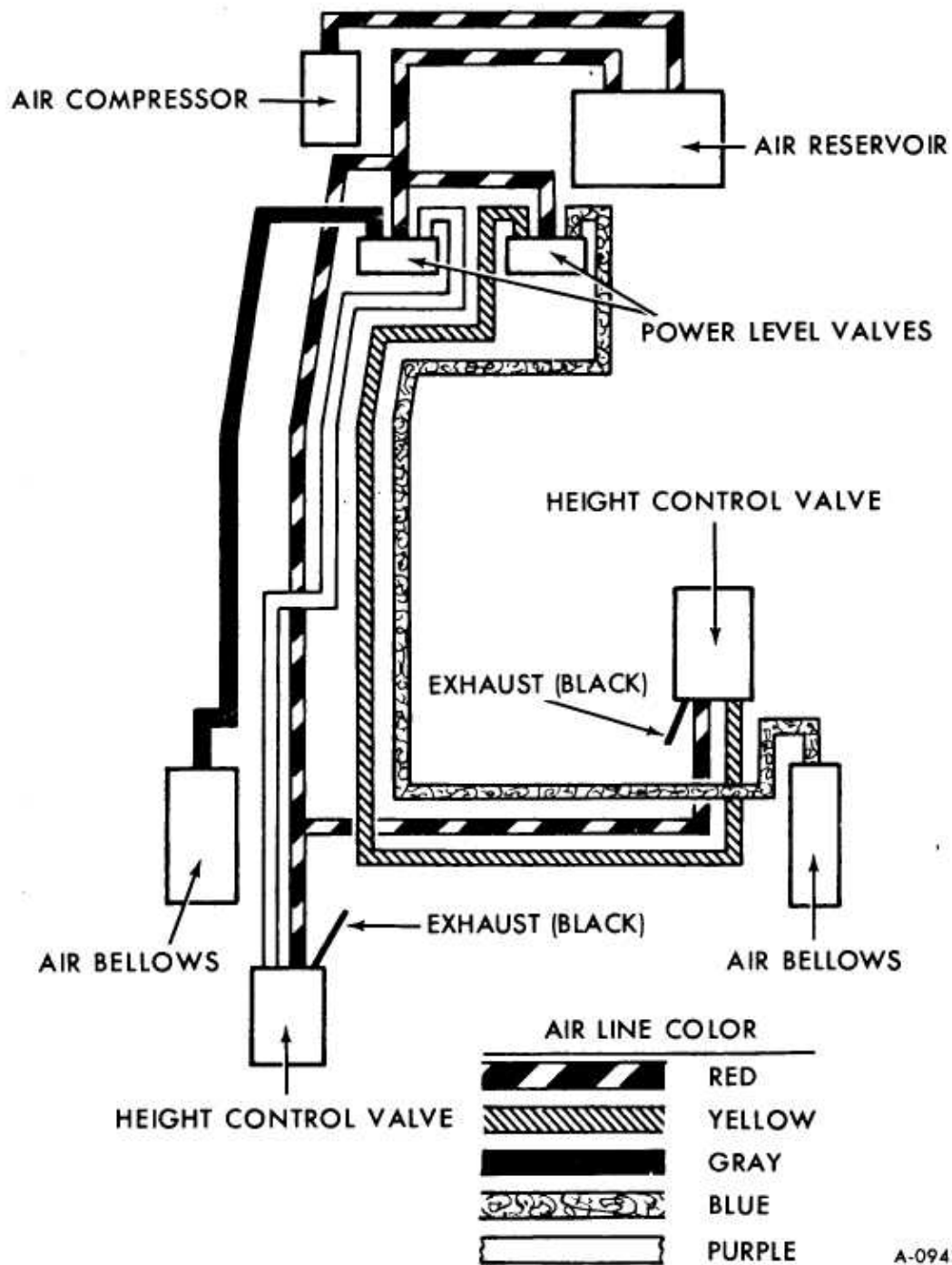

A-0943

©2-9.00 Neg. A-0943

Figure 43-Rear Suspension Schematic (With Power Level)

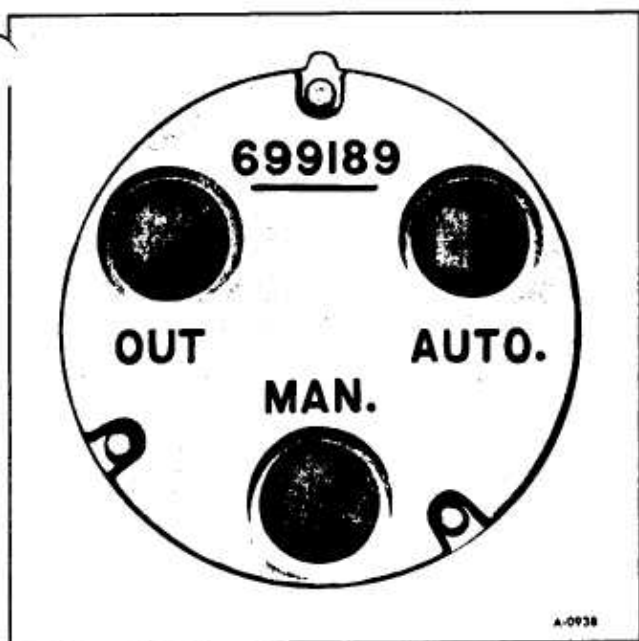

Figure 44—Power Level Valve Port Identification

knob in travel position, and operate compressor until suspension comes up to ride height. Checks for air leaks.

## AIR LINE INSTALLATION

Nylon tubing is used throughout the motor home for rear suspension air lines as shown in schematics,

Figures 42 and 43. It is flexible, durable and weather-resistant.

When installing nylon tubing make sure it is not routed close to a heat source, such as exhaust manifold or muffler. Tubing must be cut to required length and related fittings assembled.

**IMPORTANT:** Whenever threaded fittings on the rear suspension (excluding the height control valve, itself) are disassembled for any reason—be sure threads on male portion of fitting are wrapped with teflon tape or equivalent to avoid leakage.

1. Cut nylon tube to required length and be sure components are free of nicks or scratches.

2. Position nut and sleeve over tube.

3. Push tube insert into tube, then push tube and insert into fitting until firmly seated.

4. Seat sleeve into fitting, then tighten nut securely.

5. Install fitting at other end of nylon tube using the above procedure, then check for leaks.

6. If any trouble symptoms, such as slow suspension operation, indicates a restricted or clogged air lines, disconnect suspected tube or hose at both ends and blow through it to make sure the passage is clear. Inspect tubing and hose for partial restrictions such as dents or kinks. If such condition is found, replace the tubing.

## ON-VEHICLE ADJUSTMENTS

### REAR WHEEL ALIGNMENT

Proper rear wheel alignment must be maintained to ensure correct handling and satisfactory tire life.

Before checking alignment the following inspections should be made.

1. Check that tires are inflated to 60 psi.

2. Check wheel bearing adjustment and correct if necessary.

**NOTE:** Rear wheel alignment requires the vehicle to be level while being checked. Full weight must be on wheels with vehicle empty.

### TOE-IN MEASUREMENT

Toe-in may be measured from center of tire tread or from inside tires or rims. Measurements at both wheels must be made in same relationship (See "G" and "F," figure 45).

If measurement is to be made from center of tire treads, first hoist vehicle and spin wheels to obtain a center line on tire tread. Roll vehicle ahead several feet to where the inspection is to be made. This will remove any slack caused by looseness in wheel bearings.

Measure at point "F" and "G". The toe-in should follow the relationship.

$$G = F \pm .06"$$

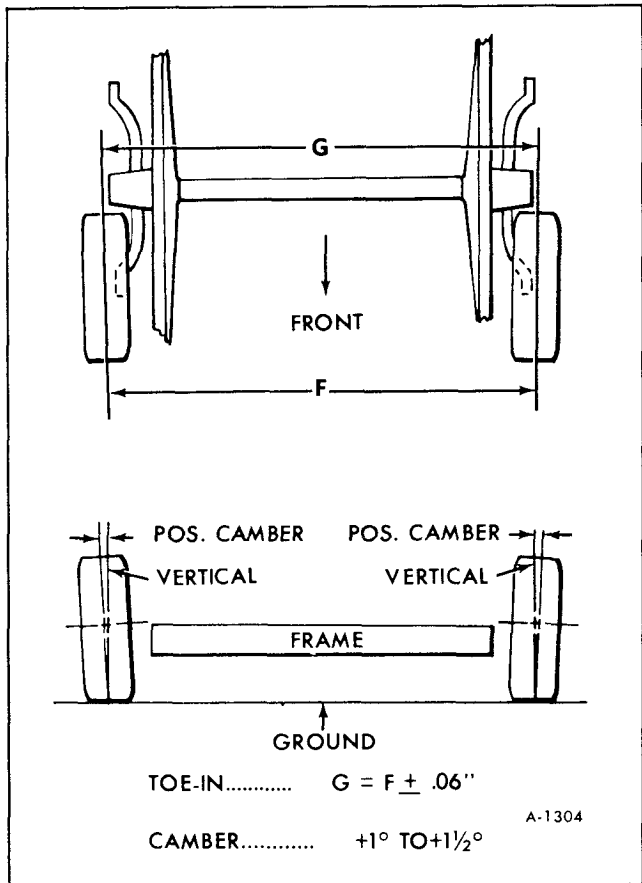

Figure 45-Rear Wheel Alignment Chart

### TOE-IN ADJUSTMENT

If toe-in is not correct it must be shimmed as shown in Figure 46. Follow this procedure for adjustment.

1. Raise vehicle off floor.

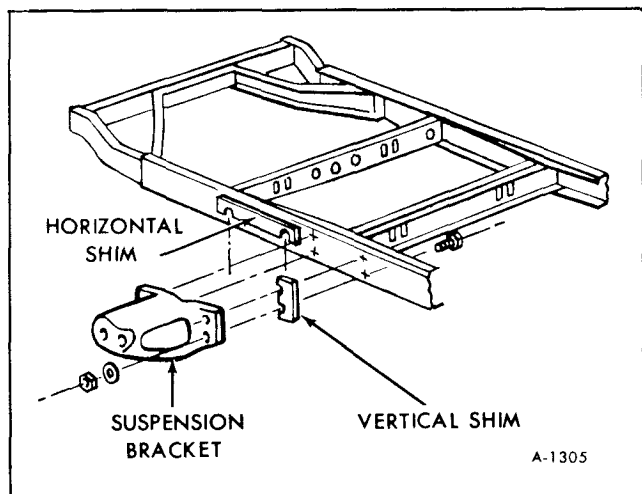

Figure 46-Rear Wheel Shim Location

2. Loosen six bolts on mounting bracket.
3. Insert proper shim as shown in Figure 46.
4. Tighten 4 retaining nuts on frame rail to 65-85 lbs.-ft. torque. Tighten 2 retaining nuts on cross-member to 50-60 lbs.-ft. torque.
5. Lower vehicle to floor and recheck alignment.

### REAR WHEEL CAMBER

The rear wheels are set with positive camber. Positive camber is outward inclination of wheels at top.

In checking camber, it is recommended that an accurate gauge be used. The camber should be set at  $+1^\circ$  to  $+1\frac{1}{2}^\circ$  (See figure 45).

Excessive positive camber results in irregular wear of tires at outer shoulder. Negative or reverse camber causes wear at inner shoulders.

Camber is adjusted by shimming as shown in Figure 46. Following the same shimming procedure as that used before to set toe-in.

### AIR COMPRESSOR PRESSURE SWITCH ADJUSTMENT

The switch is designed to maintain air pressure in the air reservoir between 100 and 120 psi. If the

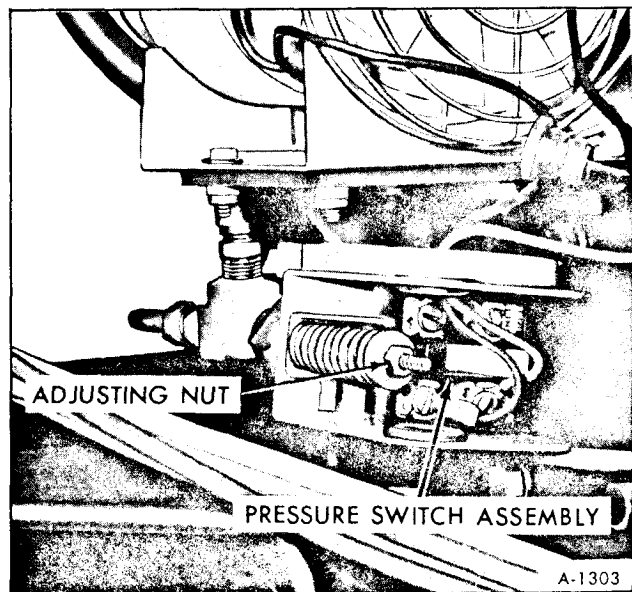

Figure 47-Air Compressor Pressure Switch Adjustment

pressure in the reservoir drops to 100 psi the contact points will close and this will complete the circuit supplying electricity to the compressor. If the pressure raises above 120 psi the contact point will open and open the circuit to the compressor. This setting may be adjusted at the nut which is located on the end of the spring inside the cover, refer to Figure 47. The pressure will rise by tightening the spring. Both the cut-in pressure and the cut-out pressure will be affected by this adjustment. The pressure can be measured at the schrader valve on the reservoir.

## RIDE HEIGHT ADJUSTMENT

The ride height at the rear suspension may be checked at an elongated slot on the frame rail, refer to Figure 48.

To adjust ride height loosen adjustment nut on height control valve (see figure 49). The valve arm has an elongated hole at the adjustment nut. This allows the valve arm to move in relation to the valve itself, and thus allows the ride height to change. Intake and exhaust valves of height control valve can then be operated independently of linkage. When proper ride height is reached tighten nut to 70-80 lbs.-in.

Height control valve lever will move 3/16 inch up or down from neutral position (free travel) without causing any valve action. If amount of adjustment required falls within these limits, adjust lever the required amount. However, frame will not raise

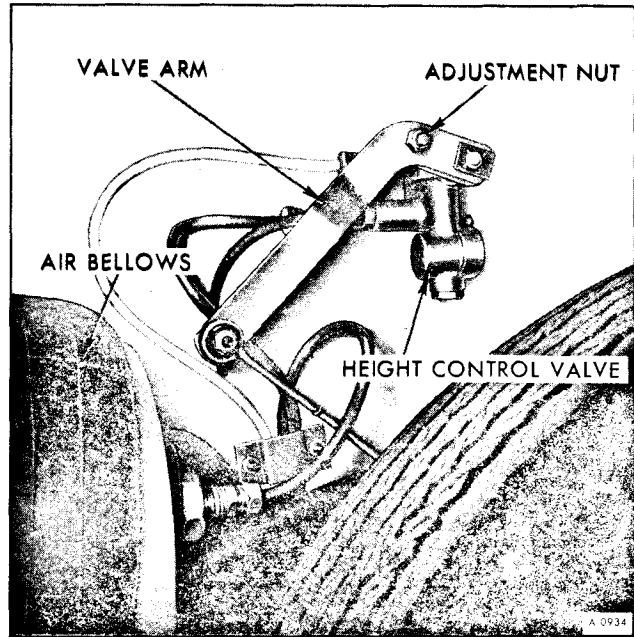

Figure 49—Location for Rear Ride Height Adjustment or lower until load is increased or decreased to actuate height control valve.

If any one of the height control valves does not function properly with the lever correctly adjusted, check for restricted air lines. If valve still does not hold frame at normal ride height with lever properly adjusted, and with no restriction in air line, valve should be overhauled or replaced with a new or rebuilt unit.

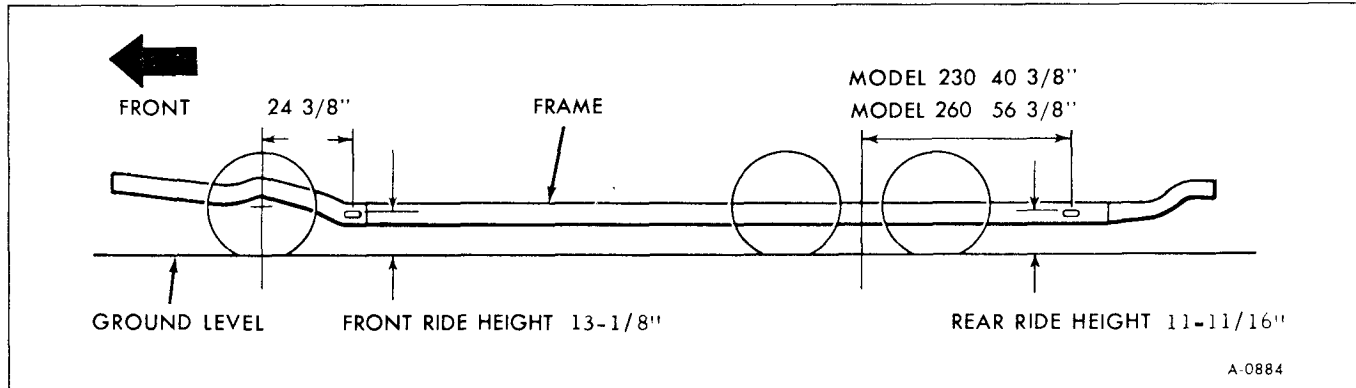

Figure 48—Checking Motor Home Ride Height

## PERIODIC MAINTENANCE

### AIR COMPRESSOR FILTER REPLACEMENT

The air filter on the compressor should be cleaned or replaced every six months or 6,000 miles.

The filter is removed by removing the filter retainer at the front of the compressor. The filter screen and filter element can now be removed. The filter element can be washed in soap and water. It should be fully dried before replacing it in the compressor.

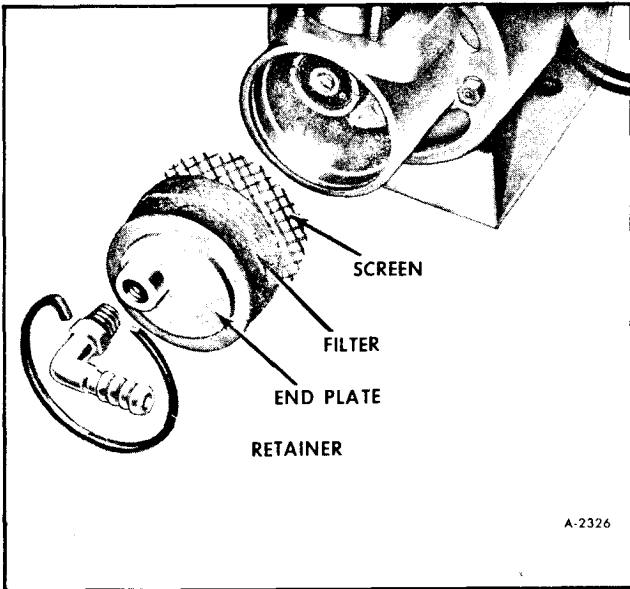

Figure 50-Compressor Air Filter Removed

## AIR RESERVOIR

Referring to Figure 5, condensation should be drained at least once a month. To drain reservoir properly, leave drain cock open until all air escapes and draining stops.

Air tank mounting bolts, and brackets should be checked at regular intervals for looseness and tighten if necessary. Air reservoir may be cleaned inside using steam or hot water. If corrosion or other damage has weakened tank it must be replaced.

## LUBRICATION

Details on lubrication of rear suspension components are covered in Section 0 at the beginning of this manual.

# REAR SUSPENSION TORQUE SPECIFICATIONS

LOCATION	TYPE OF PART	TORQUE
Center mounting bracket to frame rail nuts (4).....	Nut	65-85 ft.-lbs.
Center mounting bracket to crossmember nuts (2) .....	Nut	50-60 ft.-lbs.
Height control valve mounting Bolt .....	Bolt	80-120 in.-lbs.
Height control valve link Link to arm nut.....	Nut	60-90 ft.-lbs.
Link to control arm nut .....	Nut	60-90 ft.-lbs.
Control arm lock nut.....	Nut	15-20 ft.-lbs.