

X-7425

1973 GMC Motorhome Maintenance Manual

Table of Contents

Section	Description
0	Information, Periodic Maintenance and Lubrication
1	Body, Heating and Air Conditioning
2	Frame
3A	Front Suspension
3B	Drive Axles
3C	Final Drive
4	Rear Suspension
5	Brakes
6A	Engine
6K	Engine Cooling
6M	Engine Fuel System
6T	Emission Control Systems
6Y	Engine Electrical
7	Transmission
8	Fuel Tank and Exhaust
9	Steering System
10	Wheels and Tires
12	Chassis Electrical
13	Radiator and Coolant Recovery System
14	Bumpers
24	Miscellaneous Living Area Facilities
24A	Periodic Maintenance and Lubrication
24B	Living Area Electrical System
24C	Motor Generator
24D	Refrigerator
24E	Roof Mounted Air Conditioner (Information not available at time of publication)
24F	LP Gas System
24G	Furnace
24H	Range/Oven
24J	Living Area Water System
24K	Toilet
24L	Holding Tank and Drainage System
24M	Thermasan System
24N	Cabinets and Furniture
24P	Exhaust Vents
24Q	Other Equipment (Vacuum Cleaner) Wiring Diagrams



SECTION 7

TRANSMISSION

Contents of this section are listed below:

SUBJECT	PAGE NO.
General Information	7-1
Trouble Diagnosis	7-28
On Vehicle Servicing	7-42
Transmission Replacement	7-46
Transmission Overhaul	7-49
Transmission Specifications.....	7-86
Special Tools	7-86

GENERAL INFORMATION

DESCRIPTION

The Turbo Hydra-Matic transmission, Figure 1, is a fully automatic transmission used for front wheel drive applications.

The Turbo Hydra-matic transmission consists primarily of a three-element hydraulic torque converter, a dual sprocket and link assembly and a compound planetary gear set. Three multiple-disc clutches, a sprag unit, a roller clutch unit, and two bands provide the friction elements required to obtain the desired functions of the compound planetary gear set.

The torque converter, the dual sprocket and link, the clutches, the sprag and roller clutch, couple the engine to the planetary gears, providing three forward speeds and one reverse. The torque converter when required will supplement the gears by multiplying engine torque.

The torque converter is of welded construction and is serviced as an assembly. The unit is made up of two vaned sections, or halves, that face each other in an oil filled housing. The pump half of the converter is connected to the engine and the turbine half is, in effect, connected to the transmission.

The torque converter couples the engine to the planetary gear set through the use of a drive sprocket, a link assembly, and a driven sprocket. Clockwise engine torque turns the drive sprocket clockwise, which, in turn, drives the driven sprocket in a clockwise direction. This in effect is a reverse in the direction of engine torque due to the side mounting of the gear unit.

When the engine makes the converter pump revolve, it sends oil against the turbine, making it revolve also. The oil then returns in a circular flow back to the converter pump, continuing this flow as long as the engine is running.

The converter also has a smaller vaned section, called a stator, that funnels the oil back to the converter pump through smaller openings, at increased speed. The speeded up oil directs additional force to the engine-driven converter pump, thereby multiplying engine torque.

A hydraulic system pressurized by an internal-external type gear pump provides the working pressure required to operate the friction elements and automatic controls.

External control connections to the transmission are:

Manual Linkage—To select the desired operating range.

Engine Vacuum—To operate a vacuum modulator unit.

12 Volt Electrical Signal—To operate an electrical detent solenoid.

Gear or Torque ratios of the transmission are as follows:

First = 2.48:1 gear ratio

Second = 1.48:1 gear ratio

Third = 1.0:1 gear ratio

Reverse = 2.08:1 gear ratio

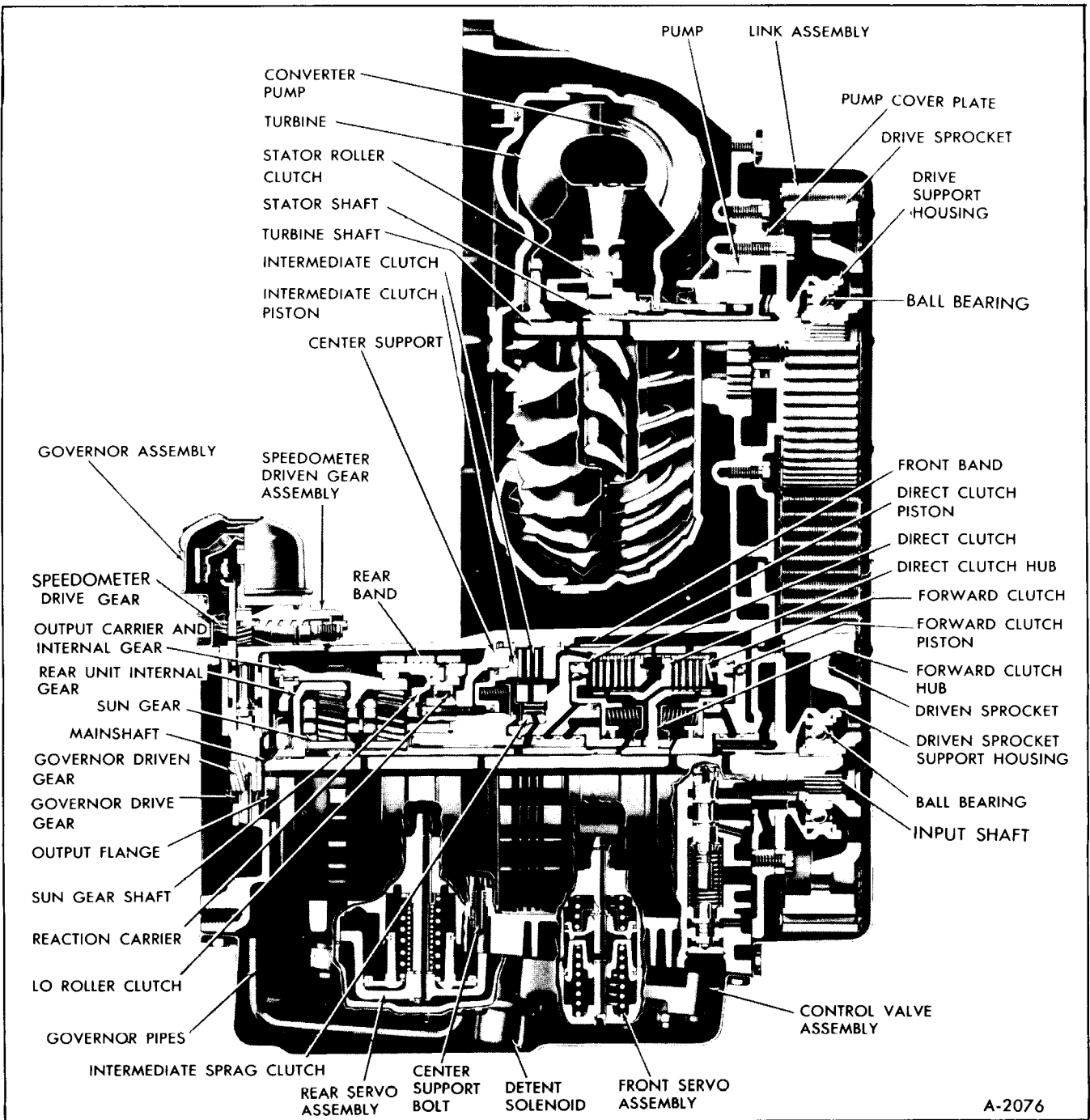

A-2076

Figure 1-Turbo Hydra-matic Transmission

First and reverse gears can be multiplied by as much as 2.2:1, depending upon the slip speed of the converter pump and turbine.

A vacuum modulator is used to sense engine torque input to the transmission automatically. The vacuum modulator transmits this signal to the pressure regulator, which controls line pressure, so that all torque requirements of the transmission are met

and proper shift spacing is obtained at all throttle openings.

The downshift solenoid is activated by an adjustable switch at the accelerator pedal. When the throttle is opened sufficiently to close this switch, the solenoid in the transmission is activated, causing a downshift at speeds below approximately 70 miles per hour. At lower speeds, downshifts will occur at

lesser throttle openings without use of the switch.

The oil cooler is located in the right hand tank of the radiator. The transmission is cooled by directing oil from the converter to the radiator. Oil returning from the radiator feeds the transmission lubrication system.

The oil system incorporates an intake pipe and filter assembly. The filter assembly should be replaced after each 12,000 miles or 12 months.

The transmission quadrant has six selector positions that enable the driver to control the operation of the transmission under various driving conditions. The six selector positions appear on the quadrant in the following sequence, from left to right; PARK-park, R-reverse, N-neutral, D-drive, S-super, L-lo.

PARK—Park position positively locks the output flange to the transmission case by means of a locking pawl and prevents the vehicle from rolling either forward or backward. For this reason, it is recommended that the engine be started with transmission selector lever in Park position. If it is necessary to re-start the engine with vehicle rolling, place selector lever in Neutral and start the engine.

R—Reverse enables the vehicle to be operated in a reverse direction.

N—Neutral position enables the engine to be started and run without driving the vehicle. It is recommended that Neutral be used to start the engine only if it is necessary to re-start the engine with the vehicle rolling. At all other times use Park.

D—Drive is used for all normal driving conditions and maximum economy. Drive has three gear ratios from starting to direct drive. Downshifts are available for safe passing by depressing the accelerator pedal.

S—Super adds performance for congested traffic or engine braking in hilly terrain. The Super range has the same starting gear ratio as Drive, but prevents the transmission from shifting above second speed to retain acceleration when extra performance is desired.

L—Lo range permits operation at a lower gear ratio, and should be used where maximum engine braking is desired, such as in descending a steep grade. When selector lever is moved from Drive to Lo range at normal highway speeds, the transmission will shift to second gear and remain in second gear until vehicle speed is reduced to approximately 45 mph. The transmission will then shift to first gear and remain in first gear regardless of vehicle or engine speed, until selector lever is moved back into either Super or Drive position.

HYDRAULIC SYSTEM

PRESSURE CONTROL

The transmission is controlled automatically by a hydraulic system, Figure 2. Hydraulic pressure is supplied by the transmission oil pump, which is engine driven. Main line pressure is controlled by a pressure regulator valve train located in the transmission case and by the vacuum modulator which is connected to engine vacuum. The pressure regulator controls line pressure automatically, in response to a pressure signal from a modulator valve in such a way that the torque requirements of the transmission clutches are met and proper shift spacing is obtained at all throttle openings and vehicle speeds.

To control line pressure properly, modulator pressure is used which varies in the same manner as torque input to the transmission. Since the torque input to the clutches is the product of engine torque and converter ratio, modulator pressure must compensate for changes in either or both of these.

To meet these requirements, modulator pressure is regulated by engine vacuum, which is an indicator of engine torque, (Governor pressure also controls modulator pressure). It will decrease with an increase in vehicle speed to compensate for the changing converter torque ratio, by virtue of the governor pressure influence.

VACUUM MODULATOR ASSEMBLY

The engine vacuum signal is received by the vacuum modulator, Figure 3, which consists of an

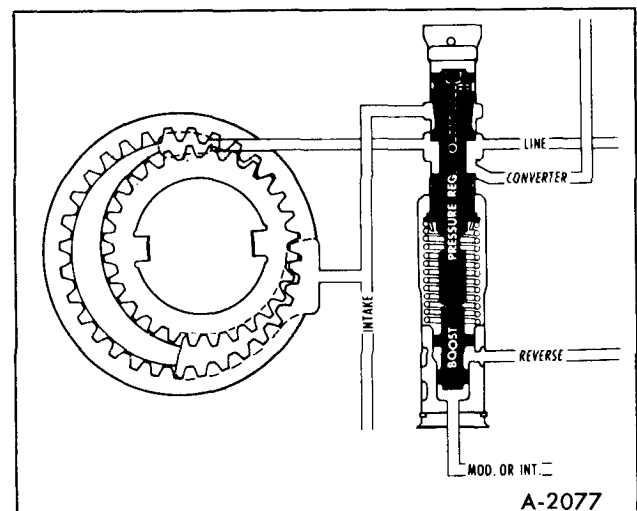

Figure 2—Pressure Control

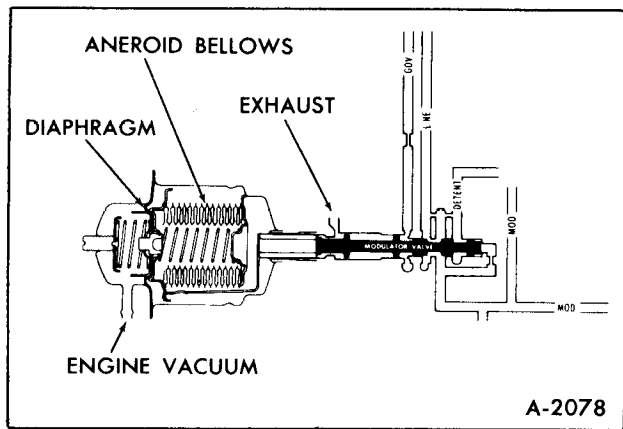

Figure 3-Vacuum Modulator Assembly

evacuated metal bellows, a diaphragm and a spring. These are so arranged that the bellows and spring apply a force that acts on the modulator valve so that it increases modulator pressure.

Engine vacuum and the enclosed spring oppose the bellows and spring to control modulator pressure.

To reduce the effect of altitude on shift points, the effective area of the diaphragm is different than that of the bellows. Atmospheric pressure acts on the resulting differential area to reduce modulator pressure.

GOVERNOR ASSEMBLY

The vehicle speed signal to the transmission is supplied by the governor, which is driven by the output flange. The governor consists of flyweights and a regulator valve. Centrifugal force of the flyweights is imposed on the regulator valve, causing it to regulate a pressure signal that increases with speed.

Governor pressure acts on the modulator valve to cause modulator pressure to decrease as vehicle speed increases.

FUNCTIONS OF VALVES AND HYDRAULIC CONTROL UNITS

Line Pressure Regulator

Regulates line pressure to satisfy engine torque.

Manual Valve

Establishes the range of transmission operation,

PARK, R, N, D, S, or L, as selected by the vehicle operator through the manual selector lever.

Governor Assembly

Generates a speed sensitive oil pressure that increases with output shaft or vehicle speed. Governor pressure is used to control the shift points and modulator pressure regulation.

Vacuum Modulator Valve

Provides modulator pressure that senses engine torque and vehicle speed. The vacuum modulator is used to vary the shift points according to throttle opening and to raise line pressure proportional to input torque to the transmission.

1-2 Shift Valve

Activates the 1-2 and 2-1 shifts.

1-2 Regulator Valve

Controls the flow of modulator pressure to the 1-2 shift valve to regulate the minimum shift point.

1-2 Detent Valve

Senses regulated modulator pressure tending to hold 1-2 shift valve downshifted and provides an area for detent pressure for detent 2-1 shifts.

2-3 Shift Valve

Activates the 2-3 and 3-2 shifts.

2-3 Modulator Valve

Senses modulator pressure to apply a variable force that tends to hold the 2-3 shift valve downshifted.

3-2 Valve

Shuts off modulator pressure from acting on the shift valves after the direct clutch has been applied. This allows fairly heavy throttle operation in third speed without downshifting. In third speed, detent pressure or modulator pressure above 87 psi can be directed to the shift valves to provide the downshift forces.

1-2 Accumulator Valve

Regulates drive oil to a proportional lesser value

that increases as modulator pressure increases, to control engagement of the intermediate clutch.

Detent Valve

Shifts when line oil is exhausted at the end of the valve when the detent solenoid is energized. This directs detent oil to the 1-2 and 2-3 modulator valves and allows the detent regulator valve to regulate.

Detent Regulator Valve

When the detent valve shifts, the detent regulator is freed to allow drive oil to enter the detent passage and thus becomes regulated at 70 psi. Detent pressures will also flow into the modulator passage which flows to the shift valves. Detent pressure acting on the modulator valve limits the low limit of modulator pressure to the value of detent pressure.

Rear Servo and Accumulator Assembly

The rear servo piston applies the rear band for engine braking in Lo range 1st gear. It applies the band in Reverse to hold the reaction carrier to provide the reverse gear ratio.

On the 1-2 shift in Drive or Super, the rear accumulator piston serves as an accumulator for the intermediate clutch to provide a smooth shift.

Front Servo

The front servo piston applies the front band to provide engine braking in 2nd gear in Super and Lo ranges. The front accumulator piston cushions the apply of the direct clutch, and in conjunction with a series of check balls controlling orifices, is a part of the timing for the release of the direct clutch.

To prevent the apply of the front band in Neutral, Drive and Reverse ranges, oil is directed from the manual valve to the release side of the servo piston.

In Drive the servo release oil from the manual valve is used to charge the servo in preparation for the apply of the direct clutch.

Direct clutch oil is directed to the front servo accumulator piston where spring force plus direct clutch pressure stroke the piston up against the force of servo release oil. This lowers the clutch apply pressure for a smooth engagement.

The release of the direct clutch and the exhausting of the front servo accumulator is slowed down by the three check balls and three orifices which permits a soft return of the drive load to the intermediate roller clutch and also allows engine rpm to increase during a detent 3-2 downshift in preparation for the lower gear ratio, which results in a smooth shift and better acceleration.

PARK OR NEUTRAL-ENGINE RUNNING

POWER FLOW

Forward Clutch – Released

Roller Clutch – Ineffective

Direct Clutch – Released

Front Band – Released

Rear Band – Released

Intermediate Clutch – Released

Intermediate Sprag – Ineffective

In Neutral or Park no bands or clutches are applied, therefore no power is transmitted.

OIL FLOW (FIGURE 4)

Whenever the engine is running at idle with the selector lever in “PARK” or “N”, oil from the pump is directed to the:

1. Converter
 - a. Oil Cooler
 - b. Lubrication System
2. Vacuum Modulator Valve
 - a. Pressure Regulator Boost Valve
 - b. 1-2 Accumulator and Primary Valves
 - c. Detent Valve
 - d. 3-2 Valve
 - e. 2-3 Shift Valve Train
 - f. 1-2 Shift Valve Train
3. Manual Valve
4. Detent Solenoid
5. Detent Valve
6. Front Servo Piston (Neutral only)

Cooling and Lubrication

Oil flows from the pump to the pressure regulator valve which regulates pump pressure. When the pump output exceeds the demand of line pressure, oil from the pressure regulator is directed to the converter feed passage to fill the converter. Oil from the converter is directed to the transmission cooler. Oil from the cooler is directed to the transmission lubrication system.

Line pressure acts on the:

1. Manual Valve
2. Detent Valve
3. Detent Solenoid
4. Modulator Valve
5. Front Servo Piston

Line pressure at the modulator valve is regulated to a pressure called modulator oil, which acts on the pressure boost valve, 1-2 accumulator and primary valves, and passes through the detent valve and 3-2 valve to the 1-2 and 2-3 valve trains.

Summary

The converter is filled. All clutches and bands are released. The transmission is in Neutral.

Figure 4-Neutral - Engine Running

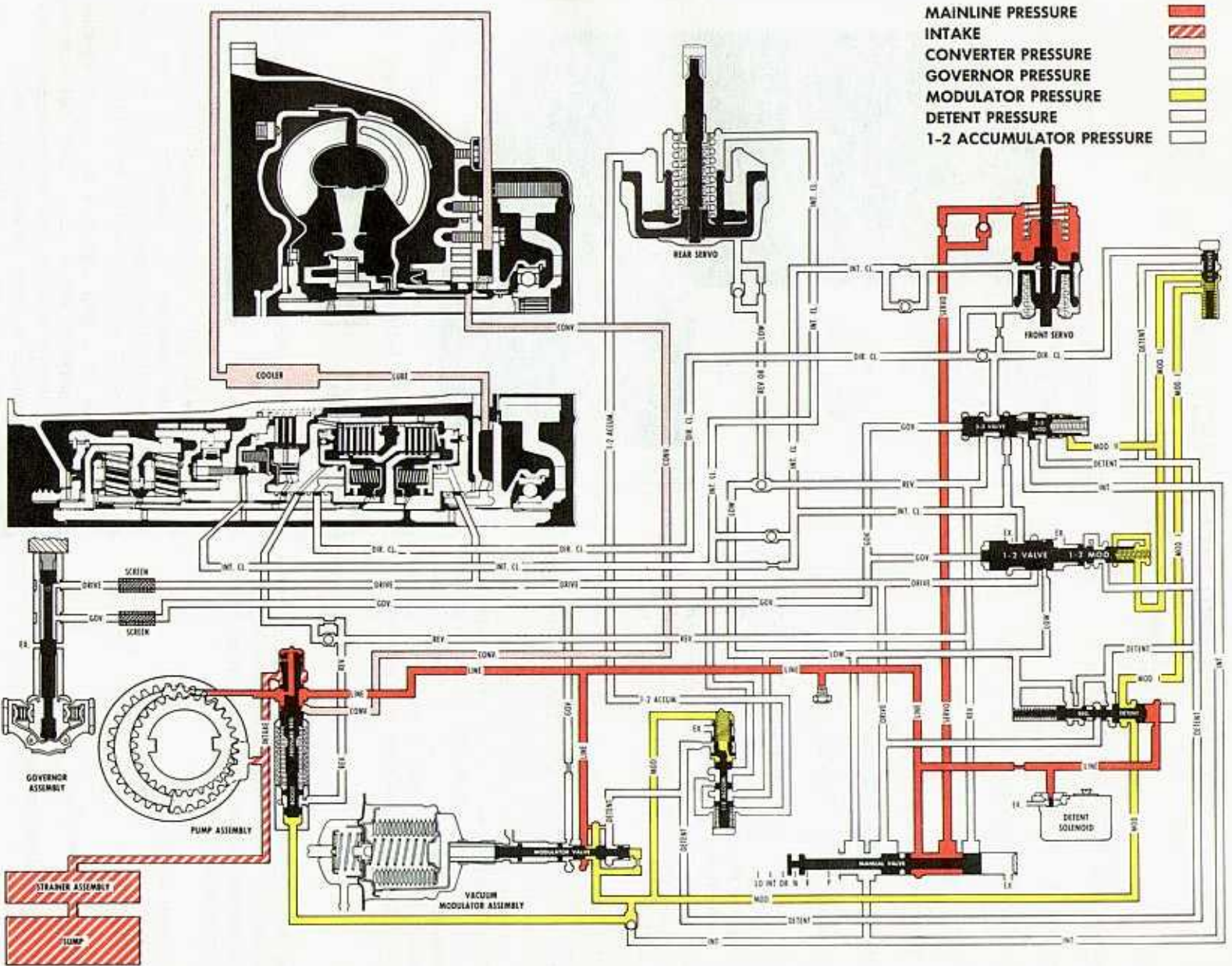

DRIVE AND SUPER-FIRST SPEED

POWER FLOW (FIGURE 5)

Forward Clutch – Applied

Roller Clutch – Effective

Direct Clutch – Released

Front Band – Released

Rear Band – Released

Intermediate Clutch – Released

Intermediate Sprag – Ineffective

With the selector lever in either Drive or Super Range, the forward clutch is applied. This delivers turbine torque to the drive sprocket, through the link assembly to the driven sprocket and mainshaft and turns the rear internal gear in a counterclockwise direction. (Converter torque ratio = approximately 2.2:1 at stall.)

Counterclockwise motion of the rear internal gear causes the rear pinions to turn counterclockwise to drive the sun gear clockwise. In turn, the sun gear drives the front pinions counterclockwise, thus turning the front internal gear, output carrier, and output flange counterclockwise in a reduction ratio of approximately 2.48:1. Reaction of the front pinions against the front internal gear is taken by reaction carrier and roller clutch assembly to the transmission case. (Approximate stall ratio – 5:1).

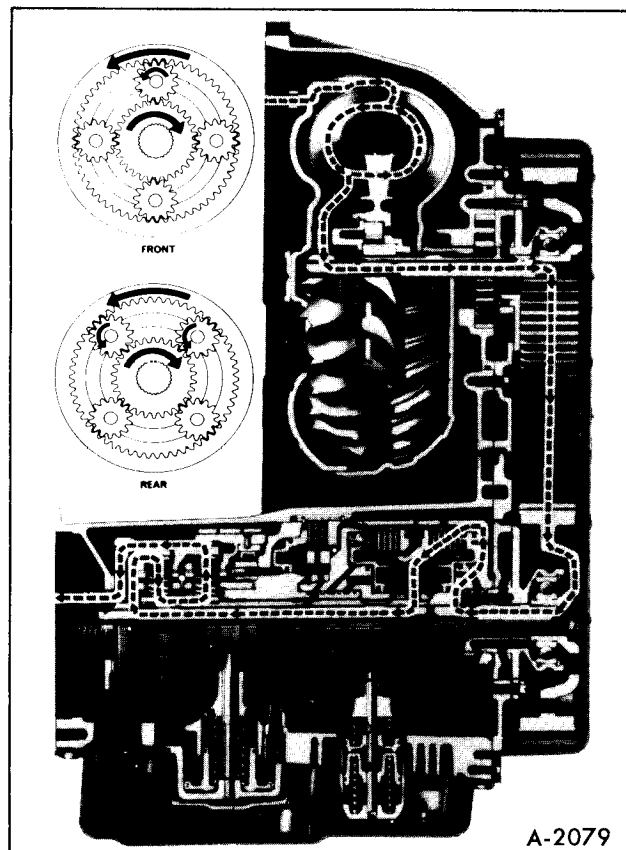

Figure 5–Drive Range–First Gear (Power)

OIL FLOW (FIGURE 6)

When the selector lever is moved to either Drive or Super position, the manual valve is repositioned to allow line pressure to enter the drive circuit. Drive oil then flows to the:

1. Forward Clutch
2. 1-2 Shift Valve
3. Governor Assembly
4. 1-2 Accumulator Valve
5. Detent Regulator Valve

Basic Control

Drive oil is directed to the forward clutch where it acts on two areas of the clutch piston to apply the forward clutch. The first, or inner area, is fed

through an unrestricted passage. The outer area is fed through an orifice to insure a smooth shift into Drive.

Drive oil at the governor assembly is regulated to a variable pressure. This pressure increases with vehicle speed and acts against the ends of the 1-2 and 2-3 shift valves and an area on the modulator valve.

Drive oil is also regulated to another variable pressure at the 1-2 accumulator valve. This pressure is controlled by modulator oil and is directed to the rear accumulator piston. In addition, to maintain the lower pressure in the 1-2 accumulator passage, the 1-2 accumulator valve intermittently uncovers the lo oil passage and oil is exhausted at the manual valve.

Summary

The converter is filled. The forward clutch is applied. The transmission is in first gear.

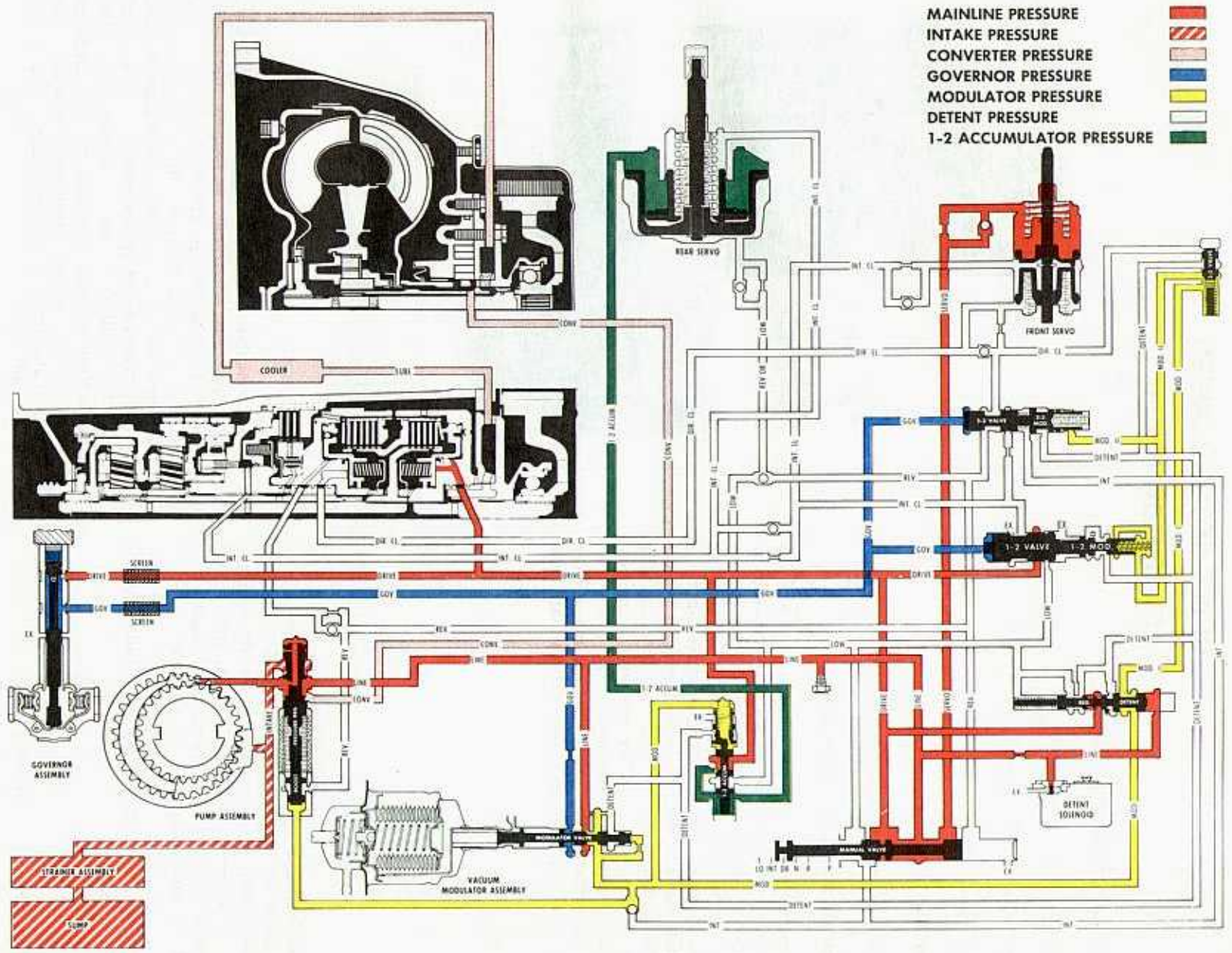

Figure 6-Drive Range-First Gear (Oil)

DRIVE-SECOND SPEED**POWER FLOW (FIGURE 7)**

- Forward Clutch – Applied
- Roller Clutch – Ineffective
- Direct Clutch – Released
- Front Band – Released
- Rear Band – Released
- Intermediate Clutch – Applied
- Intermediate Sprag – Effective

In second speed, the intermediate clutch is applied to allow the intermediate sprag to hold the sun gear against clockwise rotation. Turbine torque through the forward clutch is now applied through the drive sprocket, link assembly and driven sprocket to the mainshaft to the rear internal gear in a counterclockwise direction. Counterclockwise rotation of the rear internal gear turns the rear pinions counterclockwise against the stationary sun gear. This causes the output carrier and output flange to turn counterclockwise in a reduction ratio of approximately 1.48:1.

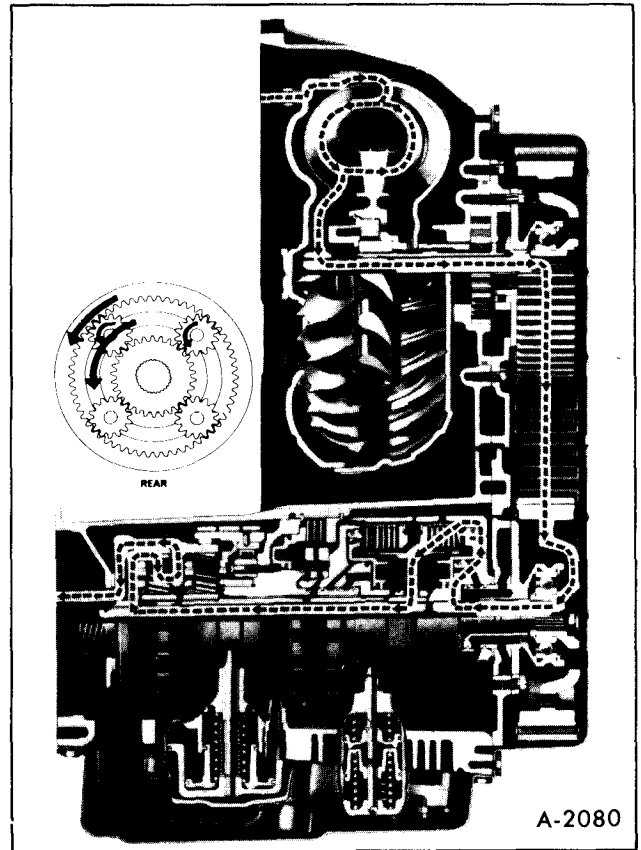

Figure 7-Drive-Second Gear (Power)

OIL FLOW (FIGURE 8)

As both vehicle speed and governor pressure increase, the force of governor oil acting on the 1-2 shift valve will overcome the force of regulated modulated oil pressure and the 1-2 valve spring. This allows the 1-2 shift valve to open, permitting drive oil to enter the intermediate clutch passage.

Intermediate clutch oil from the 1-2 shift valve is directed to the:

1. Intermediate Clutch
2. Rear Servo Accumulator
3. Front Servo Accumulator
4. 2-3 Shift Valve

Basic Control

Intermediate clutch oil from the 1-2 shift valve seats a one-way check ball and flows through an orifice to the intermediate clutch. At the same time, intermediate clutch oil moves the accumulator piston against the 1-2 accumulator oil and accumulator spring to maintain controlled pressure in the clutch during a 1-2 shift for a smooth clutch apply. Intermediate clutch oil seats a second one-way check ball and flows to the front servo and accumulator pistons. Intermediate clutch oil is also directed to a land of the 2-3 shift valve.

Summary

The forward and intermediate clutches are applied. The transmission is in second speed.

Figure 8-Drive-Second Gear (Oil)

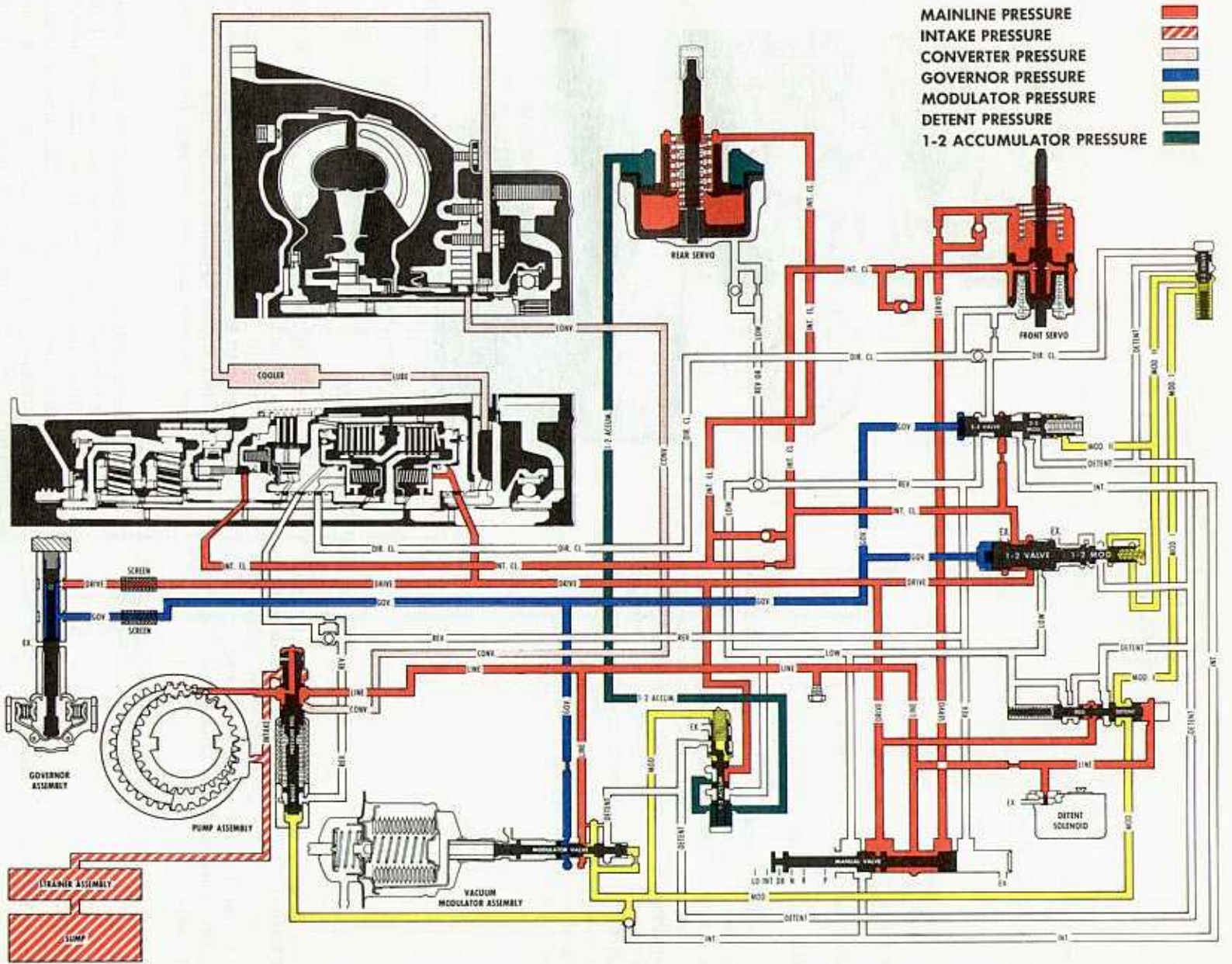

DRIVE-THIRD SPEED POWER FLOW (FIGURE 9)

- Forward Clutch – Applied
- Roller Clutch – Ineffective
- Direct Clutch – Applied
- Front Band – Released
- Rear Band – Released
- Intermediate Clutch – Applied
- Intermediate Sprag – Ineffective

In direct drive, engine torque is transmitted from the converter to the drive sprocket, through the link assembly, to the driven sprocket and through the forward clutch to the mainshaft and rear internal gear. Because the direct clutch is applied, equal power is transmitted to sun gear shaft and sun gear. Since both sun gear and internal gears are now turning at the same speed, the planetary gear set is essentially locked and turns as one unit in direct drive or a ratio of 1:1.

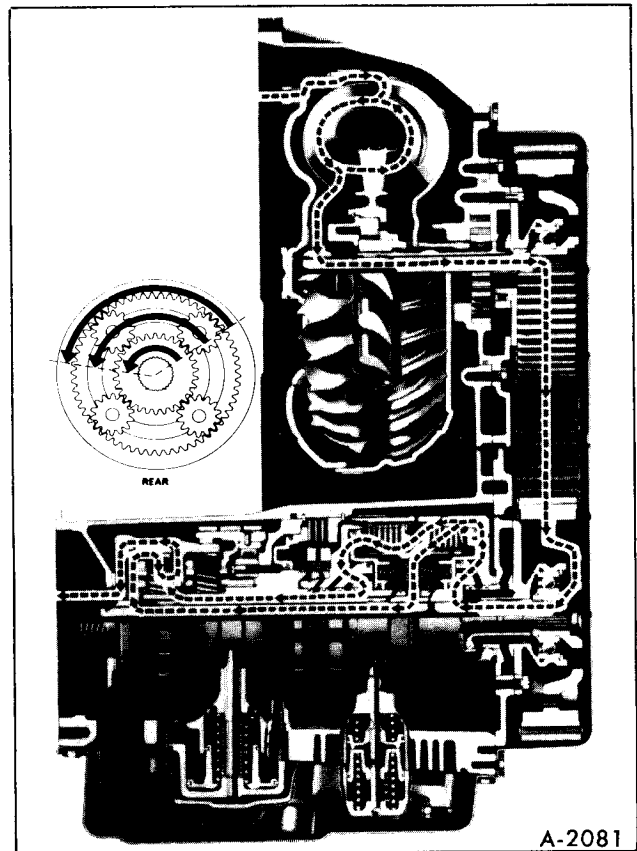

Figure 9—Drive—Third Gear (Power)

OIL FLOW (FIGURE 10)

As vehicle speed and governor pressure increase, force of governor oil acting on the 2-3 shift valve overcomes the force of 2-3 shift valve spring and modulator oil. This allows the 2-3 shift valve to move, feeding intermediate clutch oil to the direct clutch passage.

Direct clutch oil from the 2-3 shift valve is directed to the:

1. Direct Clutch
2. Front Accumulator Piston
3. 3-2 Valve

Basic Control

Direct clutch oil from the 2-3 shift valve flows past a one-way check valve to the inner area of the

direct clutch piston to apply the direct clutch. Simultaneously, direct clutch oil is fed to the front accumulator piston. Pressure of the direct clutch oil, combined with the accumulator spring, moves the accumulator and servo pistons against servo oil. This acts as an accumulator for a smooth direct clutch apply.

Direct clutch oil is also supplied to the 3-2 valve to move the valve against modulator pressure. This cuts off modulator oil to the 1-2 modulator and 2-3 modulator valves and allows the transmission to utilize the torque multiplying characteristics of the converter during medium throttle operation without downshifting.

Summary

The forward, intermediate and direct clutches are applied. The transmission is in third gear (direct drive).

Figure 10-Drive-Third Gear (Oil)

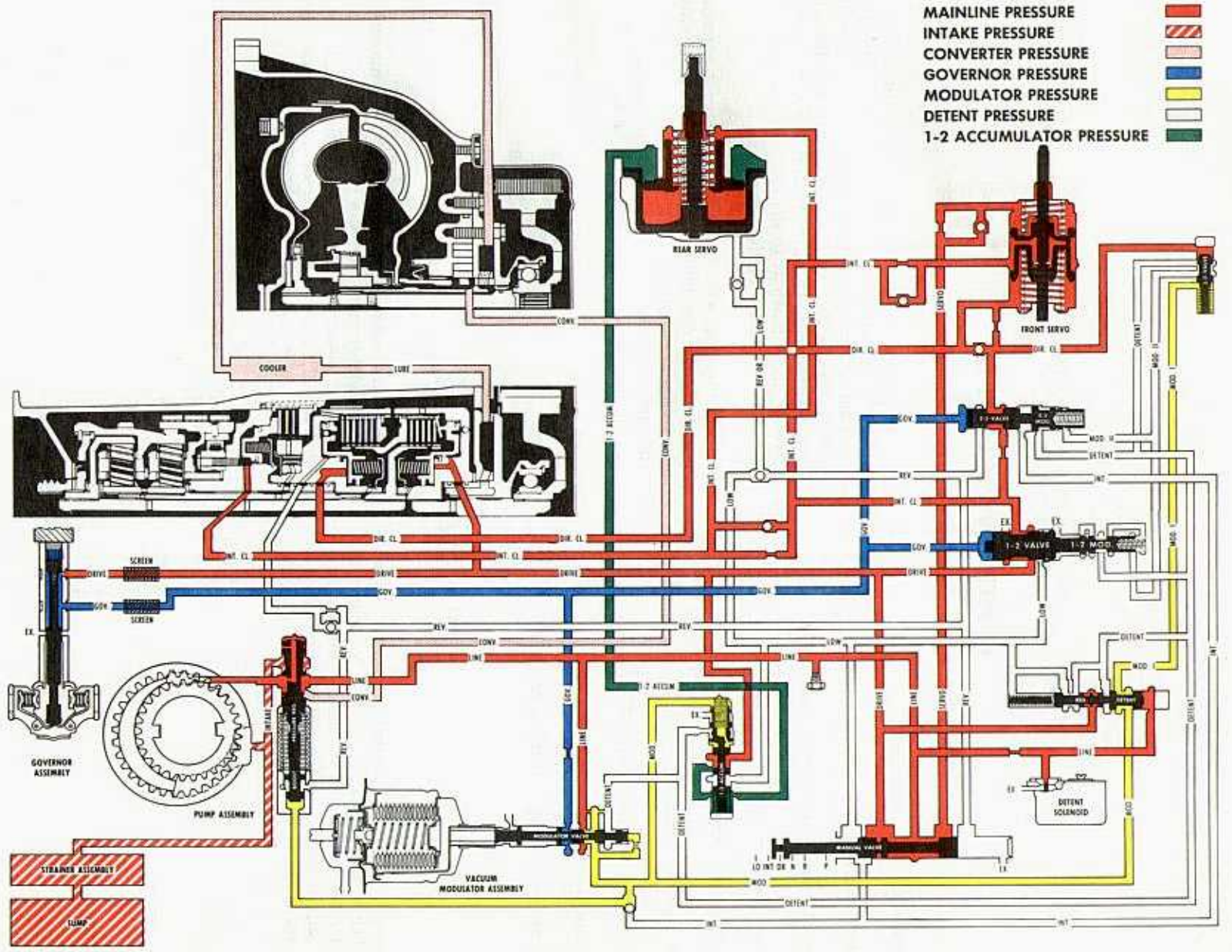

PART THROTTLE 3-2 DOWNSHIFT

POWER FLOW (FIGURE 11)

- Forward Clutch – Applied
- Roller Clutch – Ineffective
- Direct Clutch – Released in 2nd
- Direct Clutch – Applied in 3rd
- Front Band – Released
- Rear Band – Released
- Intermediate Clutch – Applied
- Intermediate Sprag – Effective in 2nd
- Intermediate Sprag – Ineffective in 3rd

In second speed, Figure 8, The intermediate clutch is applied to allow the intermediate sprag to hold the sun gear against clockwise rotation. Turbine torque through the drive sprocket, link assembly and driven sprocket to the forward clutch is now applied through the mainshaft to the rear internal gear in a counterclockwise direction.

Counterclockwise rotation of the rear internal gear turns the rear pinions counterclockwise against the stationary sun gear. This causes the output carrier and output flange to turn counterclockwise in a reduction ratio of approximately 1.48:1.

OIL FLOW (FIGURE 11)

A part throttle 3-2 downshift can be accomplished below approximately 30 mph by depressing the accelerator far enough to raise modulator pressure to approximately 81 psi. Modulator pressure and 3-2 valve spring will move the 3-2 valve against

direct clutch oil and allow modulator oil to act on the 2-3 modulator valve, moving it against the 2-3 shift valve and governor oil. The transmission will then shift to second speed, as the direct clutch oil passages are open to exhaust through lo-oil passages.

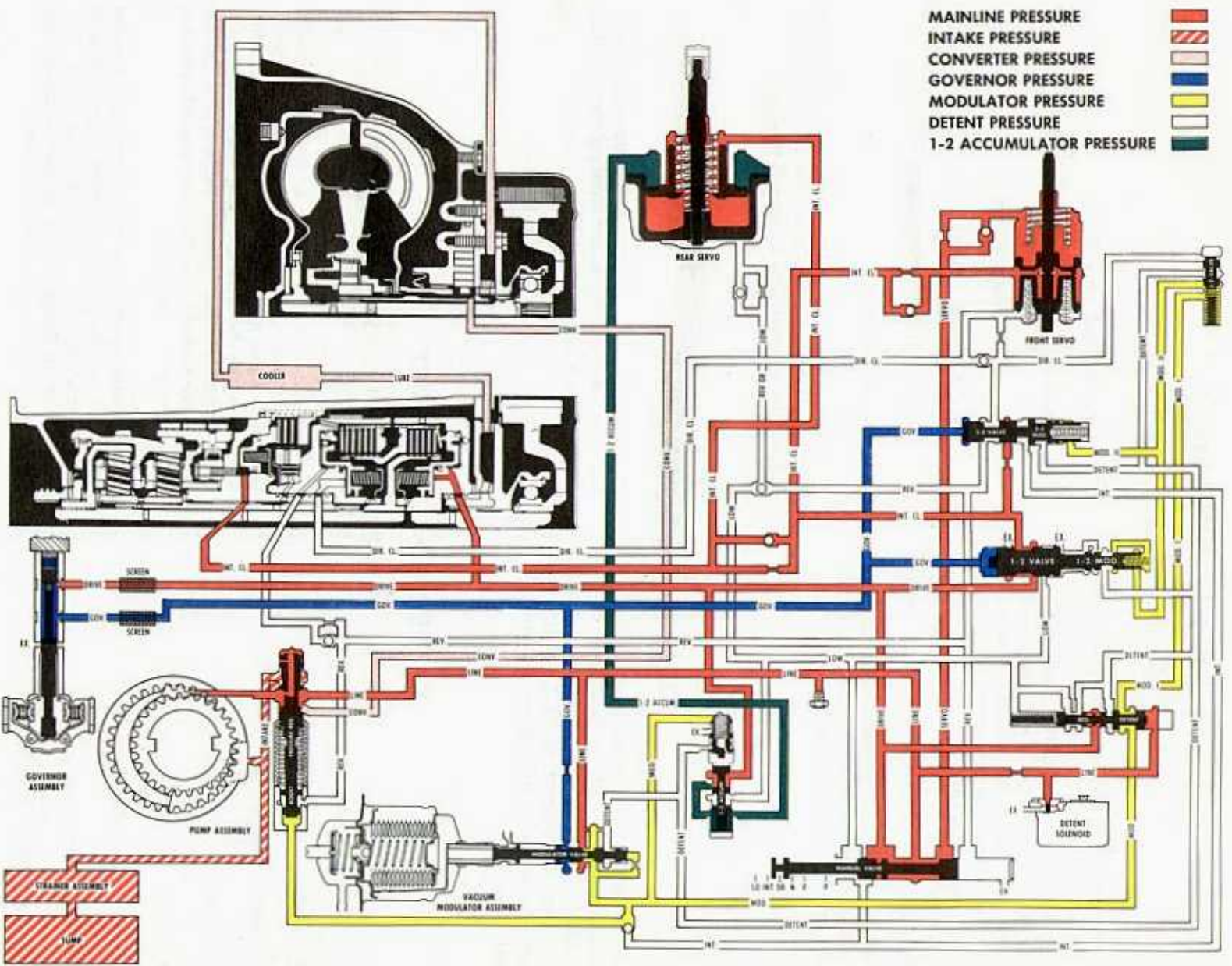

Figure 11-Part Throttle 3-2 Downshift

DETENT DOWNSHIFT

OIL FLOW (FIGURE 12)

While operating at speeds below approximately 70 mph a forced or detent 3-2 downshift is possible by depressing the accelerator fully. This energizes the switch at the accelerator pedal lever and actuates the detent solenoid. The detent solenoid opens an orifice that allows line oil at the detent valve to be exhausted, thus permitting the detent regulator valve to operate. Line oil acting on the detent valve and solenoid is supplied by a small orifice.

Drive oil on the detent regulator valve is then regulated to a pressure of approximately 70 psi and called detent oil. Detent oil is then routed to the:

1. Modulator passages

a. 3-2 Valve

b. 2-3 Modulator Valve

2. Detent Passages

a. 1-2 Modulator Valve

b. 2-3 Modulator Valve

c. 1-2 Primary Accumulator Valve

d. Modulator Valve

Detent oil in the modulator passage and at the 2-3 modulator valve will close the 2-3 shift valve, shifting the transmission to second gear.

DETENT 2-1 DOWNSHIFT

A detent 2-1 downshift can also be accomplished below approximately 25 mph because detent oil is directed to the 1-2 regulator valve. This allows detent oil to act on the 1-2 regulator, and 1-2 detent valve to close the 1-2 shift valve, shifting the transmission to first gear.

Detent oil is also directed to the modulator valve to prevent modulator pressure from regulating below 70 psi at high speeds or at high altitudes.

DETENT 3-2 DOWNSHIFT

POWER FLOW

Forward Clutch – Applied

Roller Clutch – Ineffective

Direct Clutch – Released in 2nd

Direct Clutch – Applied in 3rd

Front Band – Released

Rear Band – Released

Intermediate Clutch – Applied

Intermediate Sprag – Effective in 2nd

Intermediate Sprag – Ineffective in 3rd

In second speed, Figure 8, the intermediate clutch is applied to allow the intermediate sprag to hold the sun gear against clockwise rotation. Turbine torque through the drive sprocket, link assembly and driven sprocket to the forward clutch is now applied through the mainshaft to the rear internal gear in a counterclockwise direction.

Counterclockwise rotation of the rear internal gear turns the rear pinions counterclockwise against the stationary sun gear. This causes the output carrier and output flange to turn counterclockwise in a reduction ratio of approximately 1.48:1.

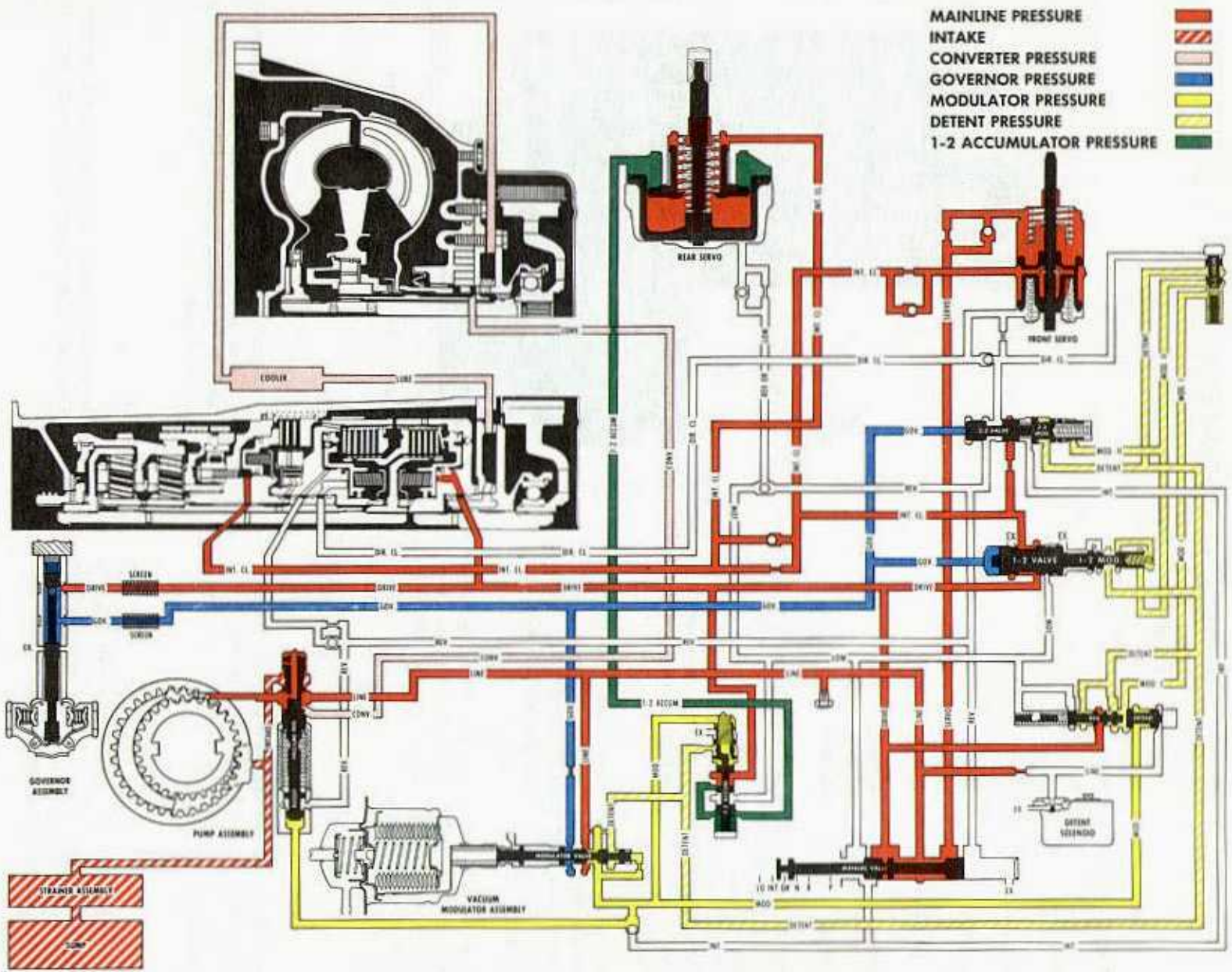

Figure 12-Detent 3-2 Downshift

SUPER-SECOND SPEED POWER FLOW (FIGURE 13)

Forward Clutch – Applied

Roller Clutch – Ineffective

Direct Clutch – Released

Front Band – Applied

Rear Band – Released

Intermediate Clutch – Applied

Intermediate Sprag – Effective

In second speed, the intermediate clutch is applied to allow the intermediate sprag to hold the sun gear against clockwise rotation. Turbine torque through the drive sprocket, link assembly and driven sprocket to the forward clutch is now applied through the mainshaft to the rear internal gear in a counterclockwise direction.

Counterclockwise rotation of the rear internal gear turns the rear pinions counterclockwise against the stationary sun gear. This causes the output carrier and output flange to turn counterclockwise in a reduction ratio of approximately 1.48:1.

In second speed – Super, engine braking is provided by the front band as it holds the sun gear fixed. Without the band applied, the sun gear would overrun the intermediate sprag.

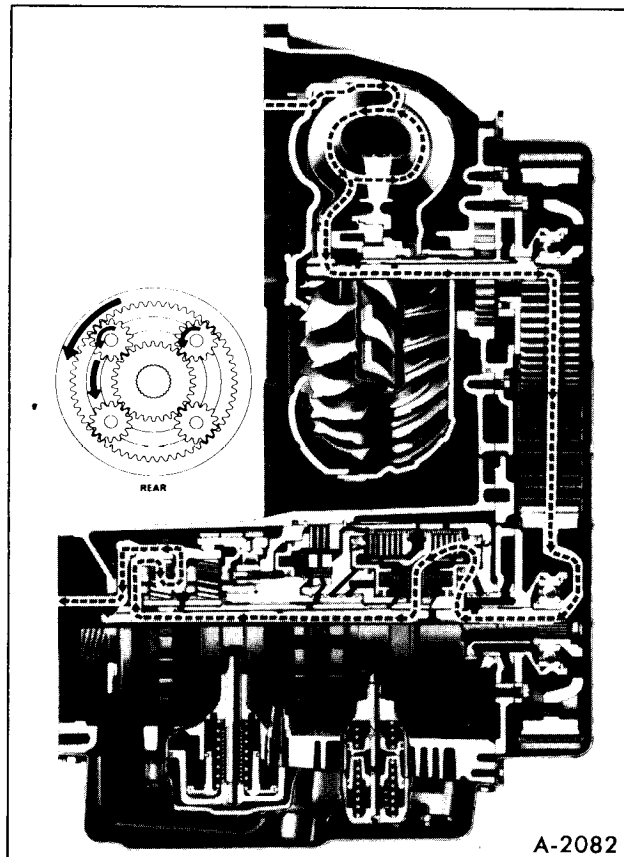

Figure 13–Super-Second Gear (Power)

OIL FLOW (FIGURE 14)

When the selector lever is in Super, intermediate oil from the manual valve is directed to the:

1. Pressure Boost Valve
2. 2-3 Shift Valve

Intermediate oil at the boost valve will increase line pressure to 150 psi. This increased intermediate oil pressure at the 2-3 shift valve will close the 2-3 shift valve, regardless of vehicle speed.

For engine braking the front band is applied by exhausting servo oil at the manual valve. This allows

intermediate clutch oil, acting on the servo piston, to move the piston and apply the front band. Once the transmission is in second speed – Super, it cannot upshift to third gear.

Summary

The forward and intermediate clutches and front band are applied. The transmission is in second gear – Super.

Figure 14-Super-Second Gear (Oil)

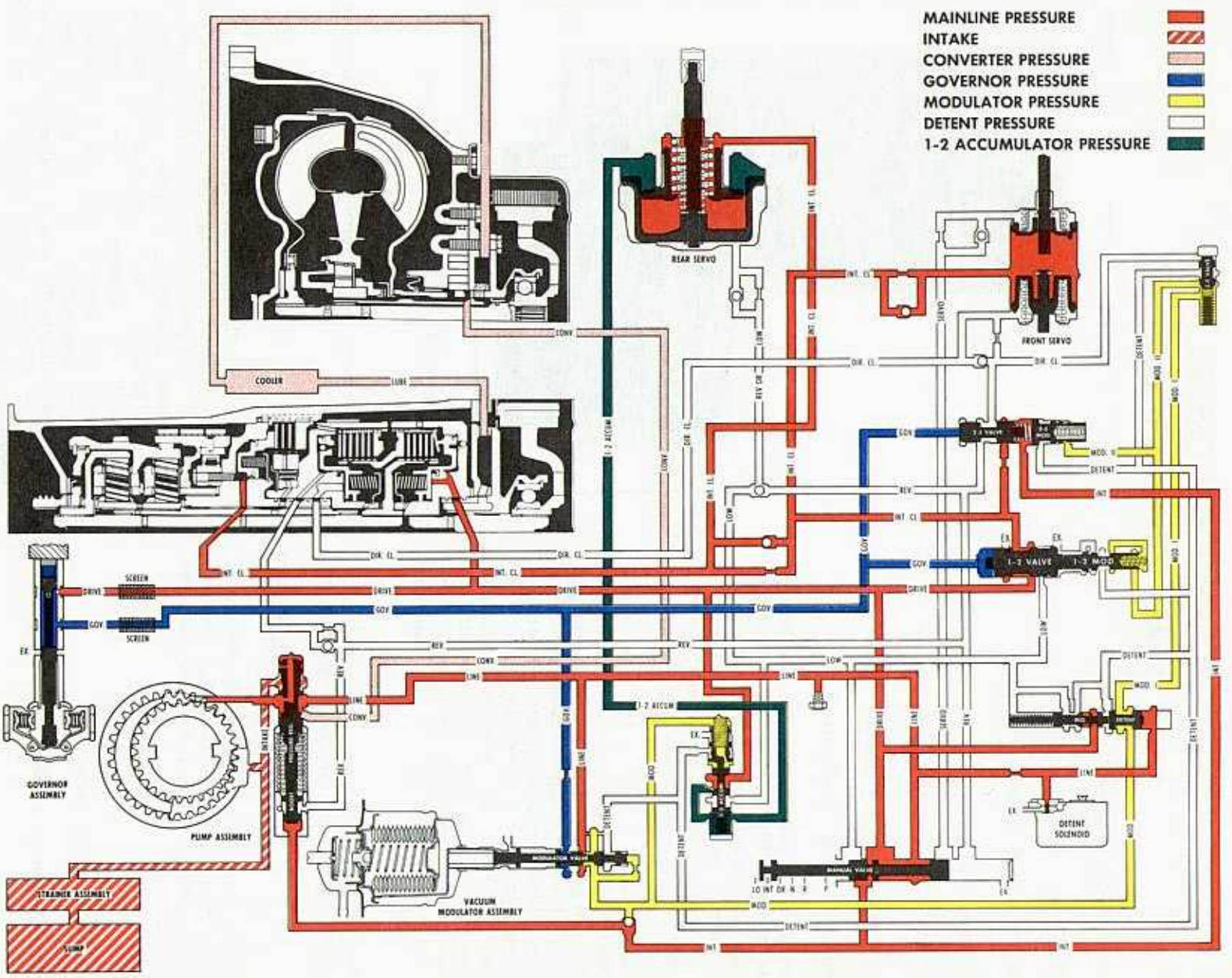

LO RANGE-FIRST SPEED POWER FLOW (FIGURE 15)

- Forward Clutch – Applied
- Roller Clutch – Effective
- Direct Clutch – Released
- Front Band – Released
- Rear Band – Applied
- Intermediate Clutch – Released
- Intermediate Sprag – Ineffective

With the selector lever in Lo range, the forward clutch is applied. This delivers turbine torque, through the drive sprocket, link assembly and driven sprocket, to the mainshaft and turns the rear internal gear in a counterclockwise direction. (Converter torque ratio = approximately 2.2:1 at stall.)

Counterclockwise motion of the rear internal gear causes the rear pinions to turn counterclockwise to drive the sun gear clockwise. In turn, the sun gear drives the front pinions counterclockwise, thus turning the front internal gear, output carrier, and output flange counterclockwise in a reduction ratio of approximately 2.48:1. The reaction of the front pinions against the front internal gear is taken by the reaction carrier and roller clutch assembly to the transmission case. (Total stall ratio = approximately 5.46:1).

Downhill or overrun braking is provided in Lo range by applying the rear band, as this prevents the

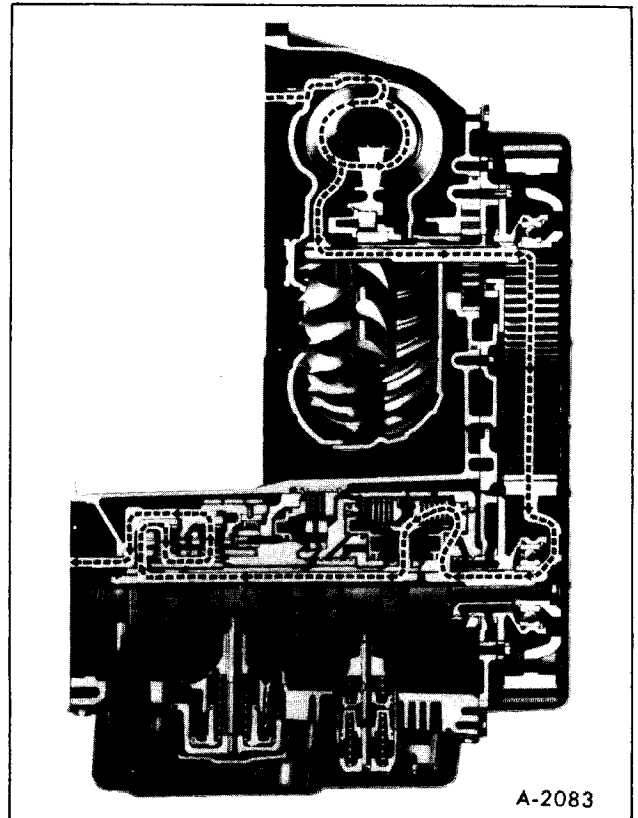

Figure 15-Lo Range-First Gear (Power)

reaction carrier from overrunning the Lo roller clutch.

OIL FLOW (FIGURE 16)

Maximum downhill braking can be attained at speeds below approximately 45 mph, with the selector lever in Lo position as this directs Lo oil from the manual valve to the:

1. Rear Servo
2. 1-2 Accumulator Valve
3. Detent Regulator Valve
4. 1-2 Shift Valve

Basic Control

Lo oil flows past a ball check to the apply side of the rear servo piston and to the 1-2 accumulator valve to raise the 1-2 accumulator oil to line pressure for a smooth band apply. Lo oil acts on the detent

regulator valve. Combined with the detent spring, Lo oil holds the detent valve against line oil acting on the detent valve, causing drive oil to flow through the detent regulator valve into the detent and modulator passages. Modulator and detent oil at line pressure acting on the 1-2 modulator valve overcomes governor oil and Lo oil on the 1-2 shift valve at any vehicle speed below approximately 40 mph, and the transmission will shift to first gear. Lo oil acts on a small area of the 1-2 shift valve to prevent the 2-1 shift occurring at too high a vehicle speed.

In first speed – Lo range, the transmission cannot upshift to second speed regardless of vehicle or engine speed.

Summary

The forward clutch and rear band are applied. The transmission is in first speed – Lo range.

Figure 16-Lo Range-First Gear (Oil)

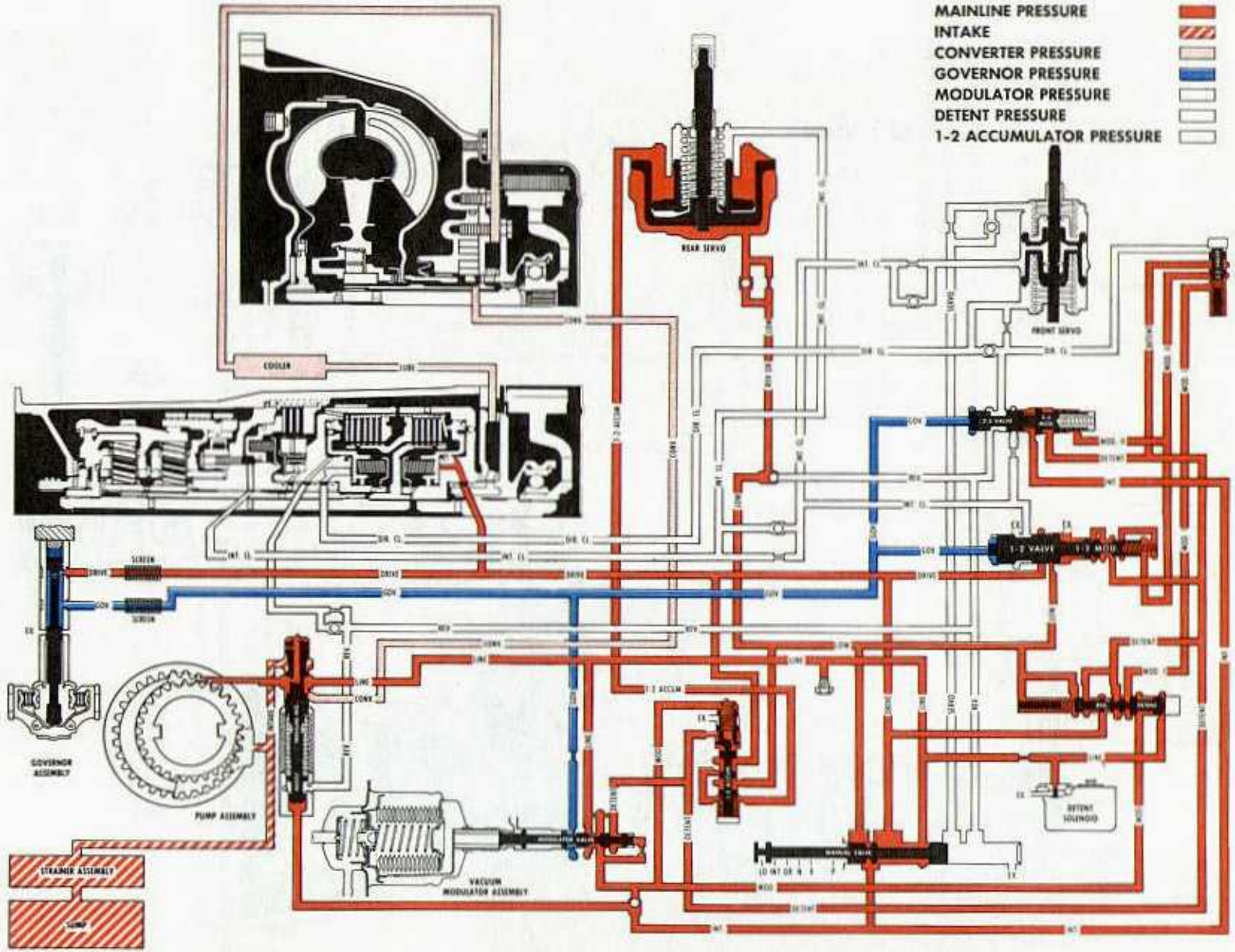

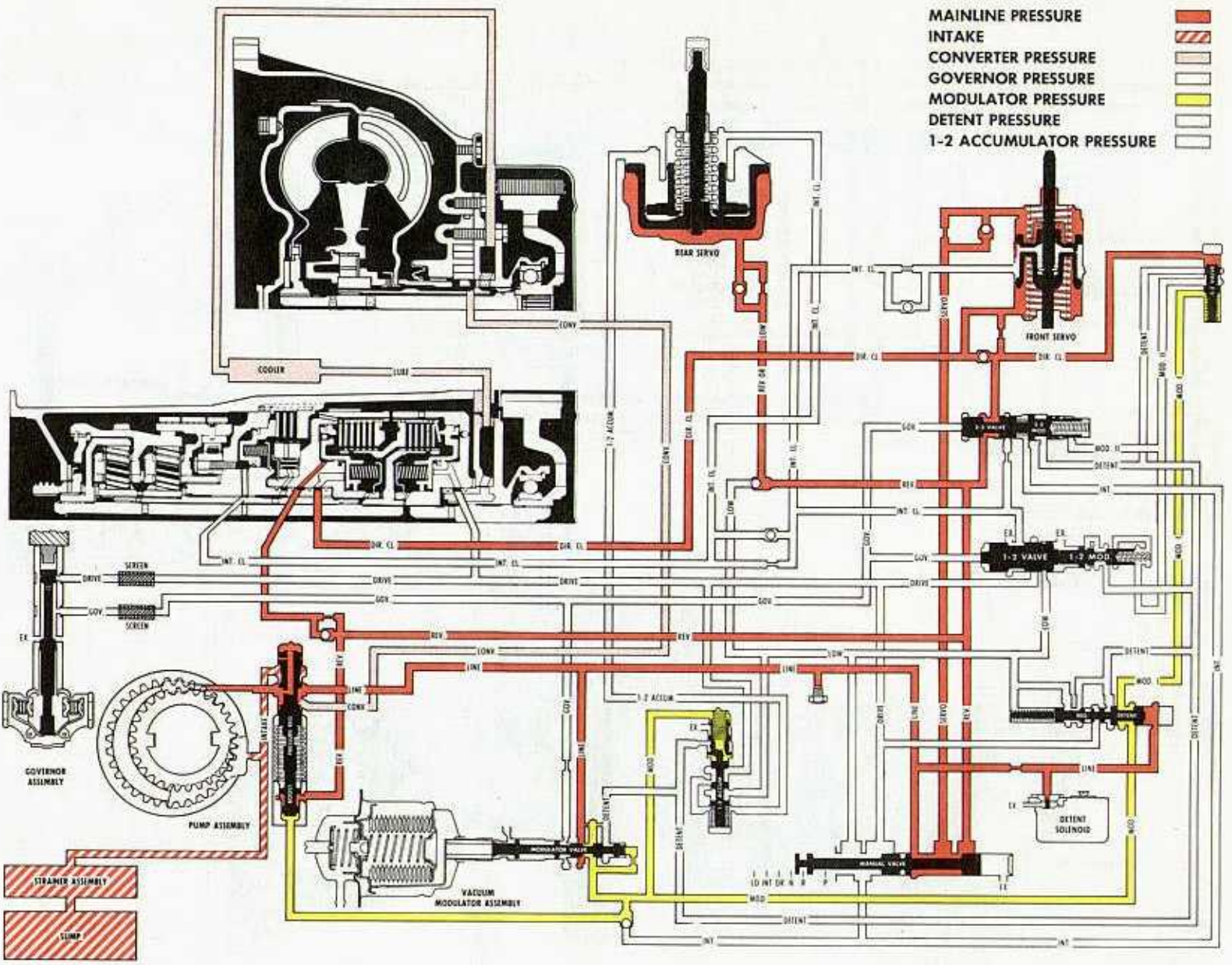

Figure 18-Reverse (Oil)

REVERSE

POWER FLOW (FIGURE 17)

Forward Clutch – Released

Roller Clutch – Ineffective

Direct Clutch – Applied

Front Band – Released

Rear Band – Applied

Intermediate Clutch – Released

Intermediate Sprag – Ineffective

In Reverse, the direct clutch is applied to direct turbine torque through the drive sprocket, link assembly and driven sprocket to the sun gear shaft and sun gear. The rear band is applied, holding the reaction carrier.

Counterclockwise torque to the sun gear causes the front pinions and front internal gear to turn clockwise in reduction. The front internal gear is connected directly to the output flange, thus providing the reverse output gear ratio of approximately 2.08:1. The reverse torque multiplication at stall (converter and gear ratios) is approximately 4.57:1.

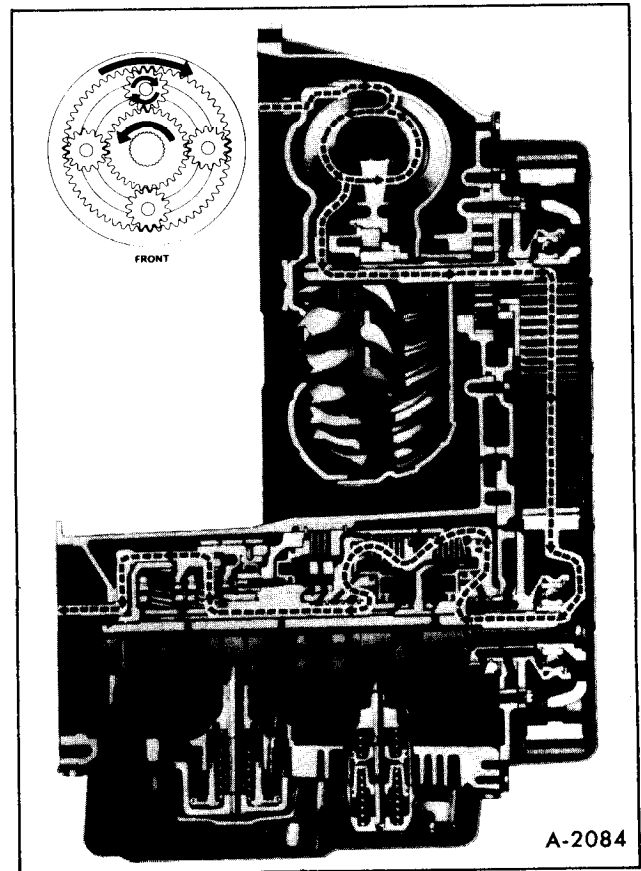

Figure 17–Reverse (Power)

OIL FLOW (FIGURE 18)

When the selector lever is moved to the Reverse position, the manual valve is positioned to allow line pressure to enter the reverse circuit. Reverse oil then flows to the:

1. Direct Clutch
2. 2-3 Shift Valve
3. Rear Servo Piston
4. Pressure Boost Valve

Basic Control

Reverse oil from the manual valve flows to the

large area of the direct clutch piston and to the 2-3 shift valve. From the 2-3 shift valve, it enters the direct clutch passage and is directed to the small area of the direct clutch piston to apply direct clutch.

Reverse oil flows to the rear servo and acts on the servo piston to apply the rear band. Reverse oil also acts on the pressure boost valve to boost line pressure.

Summary

The direct clutch and the rear band are applied. The transmission is in Reverse.

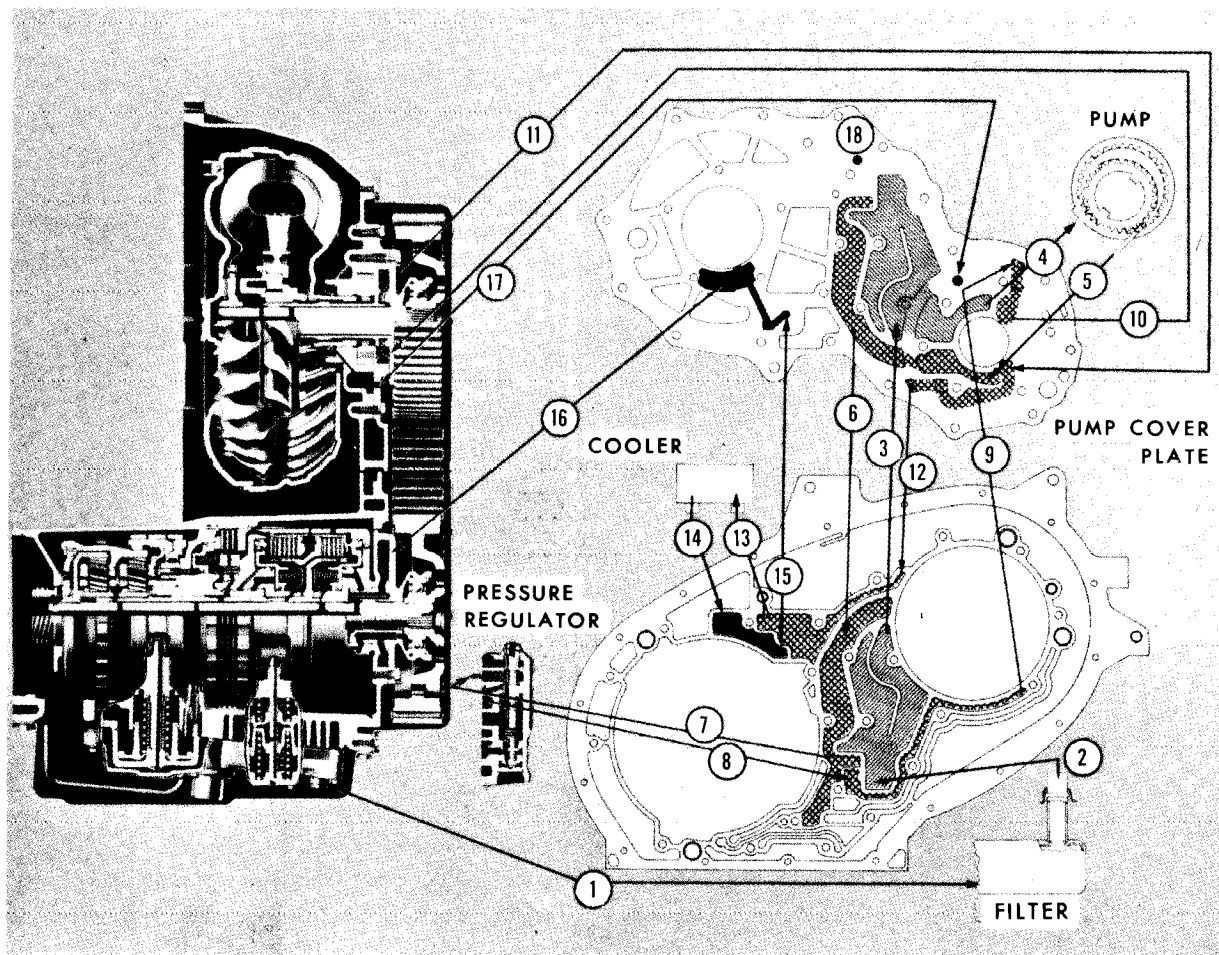

- 1 OIL FROM SUMP TO FILTER
- 2 FILTER TO CASE PASSAGE
- 3 CASE PASSAGE TO PUMP COVER PLATE PASSAGE
- 4 PUMP COVER PLATE PASSAGE TO PUMP
- 5 PUMP TO PUMP COVER PLATE PASSAGE
- 6 PUMP COVER PLATE PASSAGE TO CASE PASSAGE
- 7 CASE PASSAGE TO PRESSURE REGULATOR VALVE
- 8 PRESSURE REGULATOR VALVE TO CASE PASSAGE
- 9 CASE PASSAGE TO PUMP COVER PLATE PASSAGE
- 10 PUMP COVER PLATE PASSAGE TO CONVERTER
- 11 CONVERTER TO PUMP COVER PLATE PASSAGE
- 12 PUMP COVER PLATE PASSAGE TO CASE PASSAGE

- 13 CASE PASSAGE TO COOLER
 - 14 COOLER RETURN TO CASE PASSAGE
 - 15 CASE PASSAGE TO PUMP COVER PLATE PASSAGE
 - 16 PUMP COVER PLATE PASSAGE TO TRANSMISSION POWER TRAIN (ALL INTERNAL LUBRICATION)
- NOTE: THE NUMBERS IN THE CROSS SECTION INDICATE THAT THERE ARE ADDITIONAL LUBRICATION HOLES IN THIS AREA THAT ARE NOT SHOWN IN THE CROSS SECTION
- 17 FRONT SEAL DRAIN BACK HOLE
 - 18 PRESSURE REGULATOR VENT HOLE

A-2085

Figure 19-Lubrication Chart

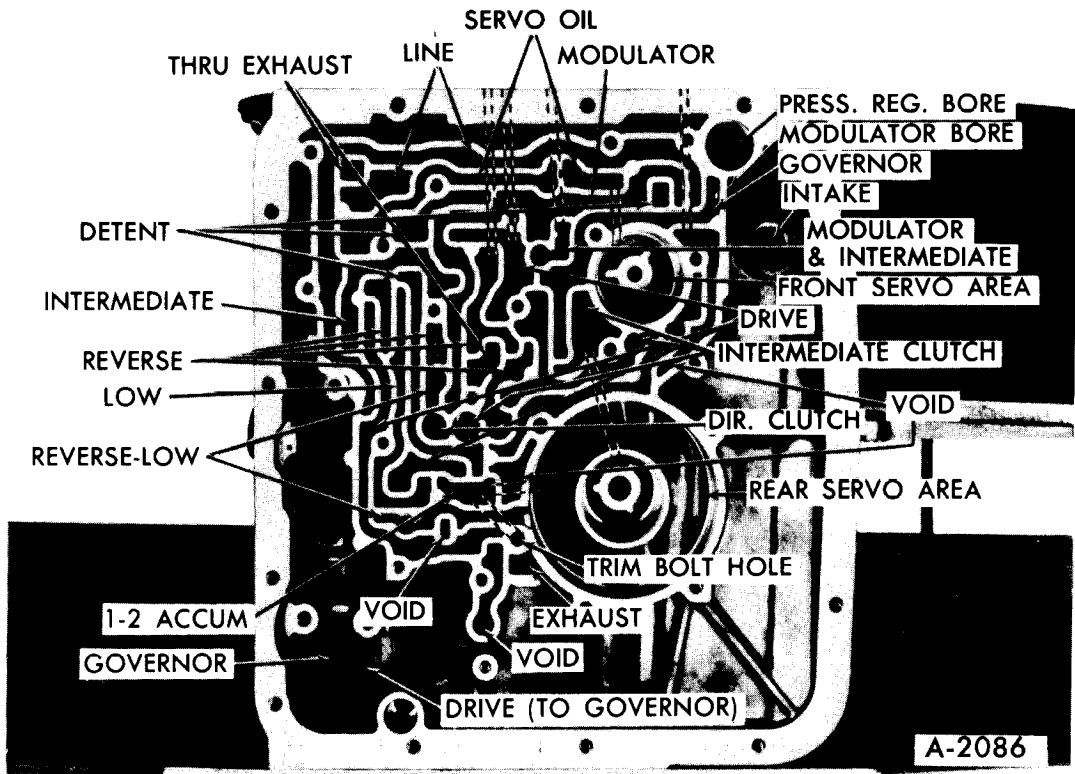
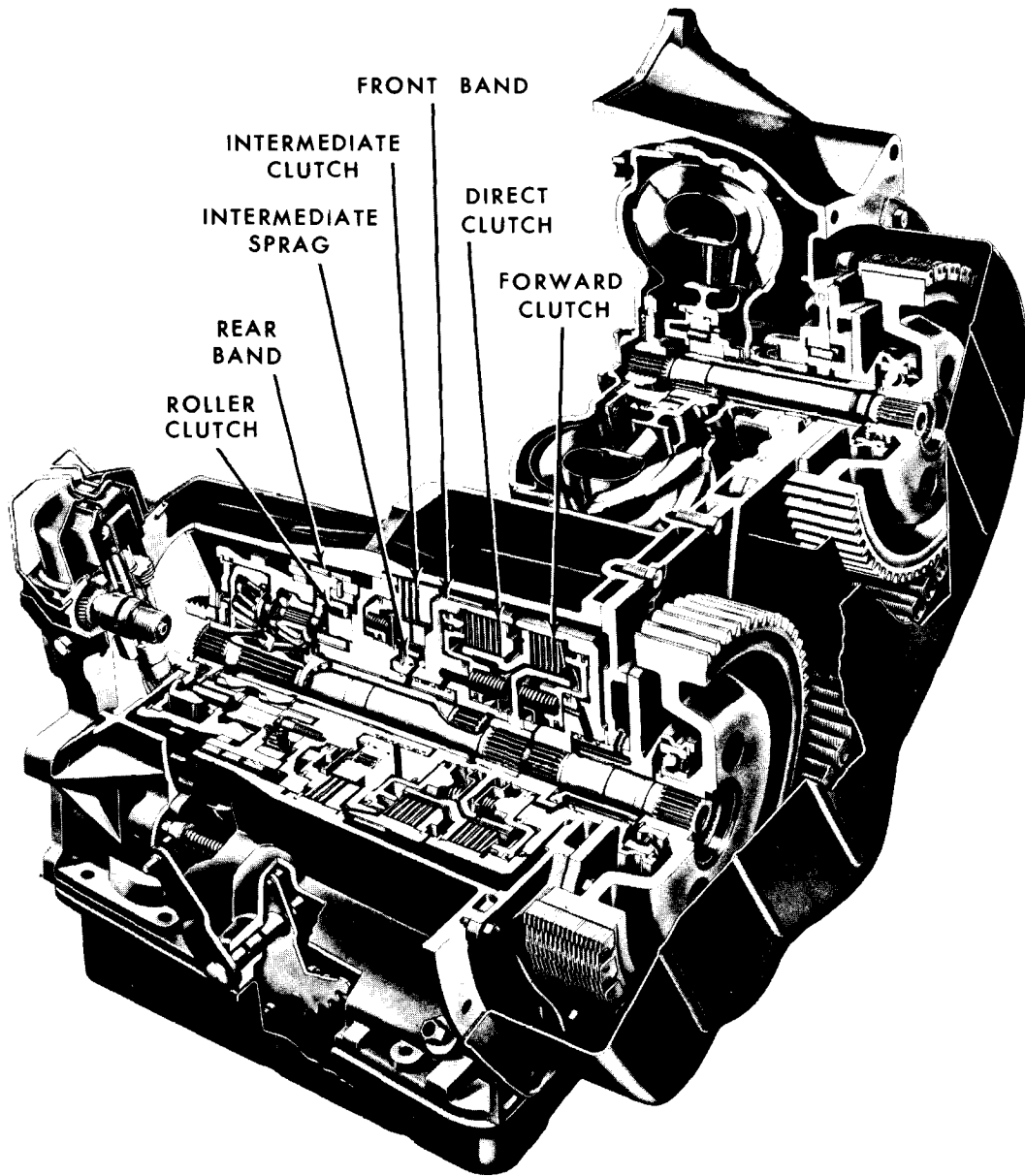

Figure 20-Case Oil Passages-Front & Bottom



A-2089

SELECTOR POSITION	PUMP PRESSURE	FORWARD CLUTCH	DIRECT CLUTCH	FRONT BAND	INT. CLUTCH	INT. SPRAG	ROLLER CLUTCH	REAR BAND
PARK-NEUT.	60-150	OFF	OFF	OFF	OFF	OFF	OFF	OFF
DRIVE 1	60-150	ON	OFF	OFF	OFF	OFF	ON	OFF
LEFT 2	60-150	ON	OFF	OFF	ON	ON	OFF	OFF
3	60-150	ON	ON	OFF	ON	OFF	OFF	OFF
DRIVE 1	150	ON	OFF	OFF	OFF	OFF	ON	OFF
RIGHT 2	150	ON	OFF	ON	ON	ON	OFF	OFF
LO 1	150	ON	OFF	OFF	OFF	OFF	ON	ON
2	150	ON	OFF	ON	ON	ON	OFF	OFF
REV.	95 - 230	OFF	ON	OFF	OFF	OFF	OFF	ON

Figure 23-Clutch, Band, and Sprag Application

TROUBLE DIAGNOSIS

FLUID LEAKAGE PRECAUTIONS

The precautions that must be observed to prevent fluid leaks are as follows:

1. Use new gaskets and O-ring seals whenever there is a disassembly.
2. Use a very small amount of petrolatum to hold gaskets and thrust washers in place during assembly, or to seal gaskets. Never use gasket paste or shellac.
3. Make sure that composition cork and paper gaskets are not wrinkled or creased when installed. Make sure that gaskets have not stretched or shrunk during storage.
4. Make sure the square type O-ring seals are installed squarely and are not twisted during assembly.
5. Make sure that mating surfaces of castings are flat and smooth, free of deep scratches, chips, and burrs.
6. Torque bolts to proper torque.

POINTS OF POSSIBLE OIL LEAKS

When checking for oil leaks, first determine whether leak originates from transmission or engine. The original factory fill fluid in the transmission is formulated with a red aniline dye to assist in locating leaks. However, the fluid color will change after a short time in service. Red dye appearing in the leaking oil will give positive identification as to the location of the leak.

If oil leak is found to be in transmission, check for leak in following areas:

REAR END

It will be necessary to remove converter cover to determine location of leaks at rear end. To correct leaks at rear end, it will be necessary to remove transmission from vehicle.

1. Pump oil seal leak – Check pump oil seal to make certain it is correctly installed and not damaged.

When installing a new pump oil seal, make certain that bore is free from foreign material and that garter spring on seal is correctly positioned. Check finish of converter neck and bearing surface in pump body.

2. Pump assembly-to-case O-ring damaged.
3. Converter – Inspect converter for indications of leakage.
4. Vent fitting damaged.

COVER AND PLATE ASSEMBLY SPROCKET HOUSING LEAK

1. Attaching bolts not correctly torqued.
2. Housing to case gasket improperly installed or damaged.
3. Housing to case gasket face not flat.

FINAL DRIVE TO TRANSMISSION LEAK

1. Attaching bolts not correctly torqued.
2. Final drive to transmission gasket improperly installed or damaged.
3. Mounting surfaces not flat.

TRANSMISSION CASE

1. Speedometer driven gear housing retainer attaching screw loose. Tighten to 18 foot-pounds.
2. Speedometer driven gear housing O-ring or lip seal damaged.
3. Governor cover bale-type attaching retainer not tight.
4. Damaged governor O-ring.
5. Solenoid connector terminal O-ring damaged.
6. Manual shaft O-ring damaged.

7. Vacuum modulator damaged.

8. Vacuum modulator retainer screw loose. Tighten to 18 foot-pounds.

9. Vacuum modulator diaphragm damaged, (not an external oil leak).

NOTE: A ruptured diaphragm would allow transmission oil to be drawn into intake manifold and vacuum line. Usually the exhaust will be excessively smoky due to transmission oil added to the combustion. Oil level of transmission will also be low.

10. Bottom pan gasket damaged.

11. Bottom pan attaching screws loose. Tighten to 12 foot-pounds.

12. Line pressure plug not tight. Tighten to 10 foot-pounds.

13. Porous or cracked casting.

14. Vent pipe.

a. Transmission over-filled.

b. Water in oil.

c. Pump to case gasket mispositioned.

d. Foreign material between pump and case, or between pump cover and body.

e. Case – Porous, pump face improperly machined.

f. Pump – Shy of stock, porous.

OIL COOLER PIPE CONNECTIONS

1. Outside oil cooler pipe connections improperly installed or damaged. Also connectors in radiator and transmission.

2. Oil cooler pipe connections not tight. Tighten to 20 foot-pounds.

3. Flare on oil cooler pipes damaged at radiator or transmission.

FILLER PIPE

1. O-ring damaged or improperly installed on pipe.

2. Filler Pipe not fully seated in case.

INTERNAL LEAKS

It will be necessary to remove bottom pan to determine location of internal leaks.

1. Governor pipes damaged.

2. Control valve assembly-to-spacer or case gaskets damaged.

3. Control valve assembly attaching screws loose. Tighten to 8 foot-pounds.

4. Solenoid gaskets damaged.

5. Solenoid attaching screws loose. Tighten to 8 foot-pounds.

6. Intake pipe O-ring damaged.

7. Rear servo square cut O-ring improperly installed or damaged.

FUNCTIONAL DIAGNOSIS PROCEDURE

ROAD TEST

Check All Shifts In The Following Manner:

DRIVE RANGE:

Position selector lever in DRIVE RANGE and accelerate the vehicle from 0 mph. A 1-2 and 2-3 shift should occur at all throttle openings. (The shift points will vary with the throttle opening). As the vehicle decreases in speed to 0 mph, the 3-2 and 2-1 shifts should occur.

SUPER RANGE:

Position the selector lever in SUPER RANGE and accelerate the vehicle from 0 mph. A 1-2 shift should occur at all throttle openings. (No 2-3 shift can be obtained in this range). The 1-2 shift point will vary with throttle opening. As the vehicle decreases in speed to 0 mph, a 2-1 shift should occur. **NOTE:** The 1-2 shift in SUPER RANGE is somewhat firmer than in DRIVE RANGE. This is normal.

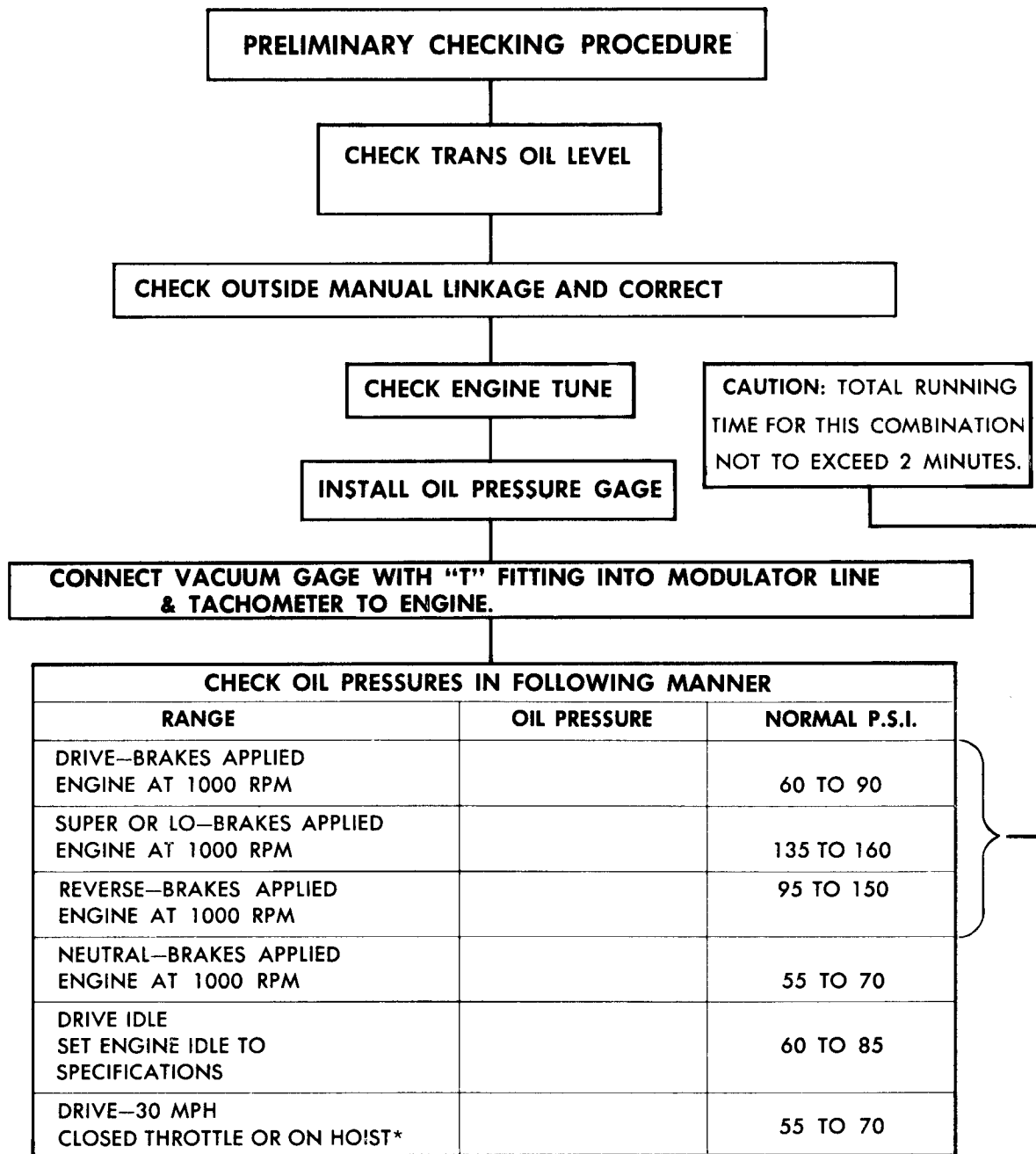

*THE DRIVE—30 MPH CLOSED THROTTLE PRESSURE READING MAY BE TAKEN DURING A ROAD TEST OR:

1. VEHICLE ON HOIST—DRIVING WHEELS OFF GROUND, FOOT OFF BRAKE, IN DRIVE RANGE.
2. Engine 2000 RPM.
3. CLOSE THROTTLE (FOOT OFF ACCELERATOR) AND TAKE PRESSURE READING ENGINE 2000-1200 RPM.

NOTE: WITH CLOSED THROTTLE AND DRIVING WHEELS OFF THE GROUND, ENGINE RPM WILL DROP RAPIDLY. PRESSURE READING MUST BE TAKEN WITHIN RPM'S INDICATED AND WITH CLOSED THROTTLE.

TRANSMISSION MALFUNCTION RELATED TO OIL PRESSURE
(PRESSURES OBTAINED BY THE PRELIMINARY CHECKING PROCEDURE)

MALFUNCTION	DRIVE BRAKES APPLIED 1000 RPM	REVERSE BRAKES APPLIED 1000 RPM	SUPER OR LO BRAKES APPLIED 1000 RPM	NEUTRAL BRAKES APPLIED 1000 RPM	DRIVE 30 MPH CLOSED THROTTLE	DRIVE IDLE	PRESSURE DROP OCCURS WHILE ENGINE RPM INCREASES FROM 1000 TO 3000 RPM WHEELS FREE TO MOVE*	POSSIBLE CAUSE OF MALFUNCTION
	OIL PRESSURE	OIL PRESSURE	OIL PRESSURE	OIL PRESSURE	OIL PRESSURE	OIL PRESSURE		
NO 1-2 UPSHIFT AND/OR DELAYED UPSHIFT	NORMAL	NORMAL	NORMAL	NORMAL	NORMAL	NORMAL	DROP	MALFUNCTION IN CONTROL VALVE ASSY.
	NORMAL	NORMAL	NORMAL	NORMAL	NORMAL	NORMAL	NO DROP	MALFUNCTION IN GOVERNOR OR GOVERNOR FEED SYSTEM
	HIGH	NORMAL	NORMAL	NORMAL	HIGH	—	—	MALFUNCTION IN DETENT SYSTEM
	HIGH	HIGH	NORMAL	HIGH	—	—	—	MALFUNCTION IN MODULATOR OR VACUUM FEED SYSTEM TO MODULATOR
SLIPPING—REVERSE	NORMAL	LOW	NORMAL	NORMAL	NORMAL	—	—	OIL LEAK IN FEED SYSTEM TO THE DIRECT CLUTCH
SLIPPING—1ST GEAR	LOW	NORMAL	LOW TO NORMAL	NORMAL	LOW TO NORMAL	—	—	OIL LEAK IN FEED SYSTEM TO THE FORWARD CLUTCH

* DRIVE RANGE, VACUUM LINE DISCONNECTED TO MODULATOR

**NO 1-2 UPSHIFT AND/OR DELAYED UPSHIFT
OR 1-2 & 2-3 UPSHIFT—FULL THROTTLE ONLY**

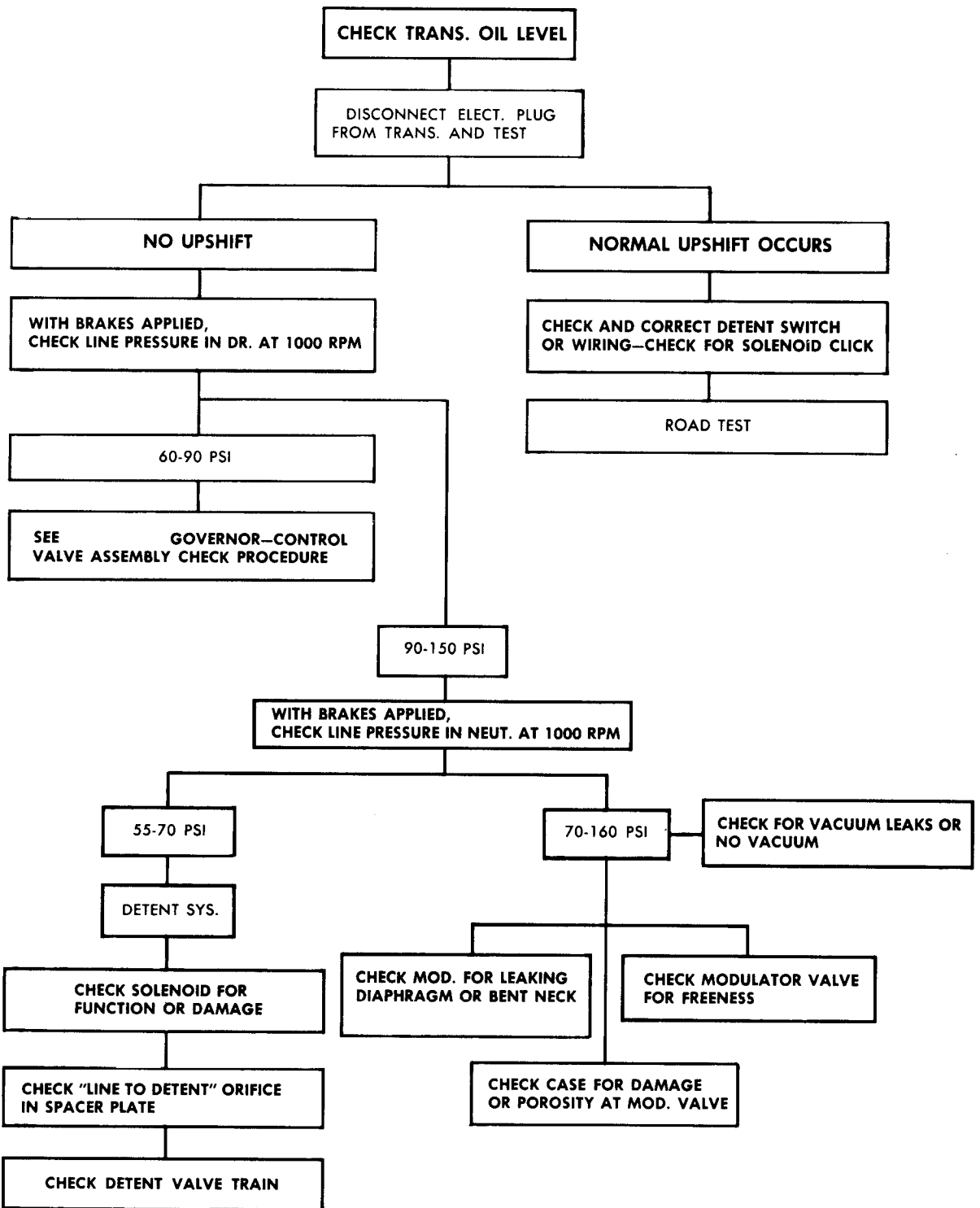

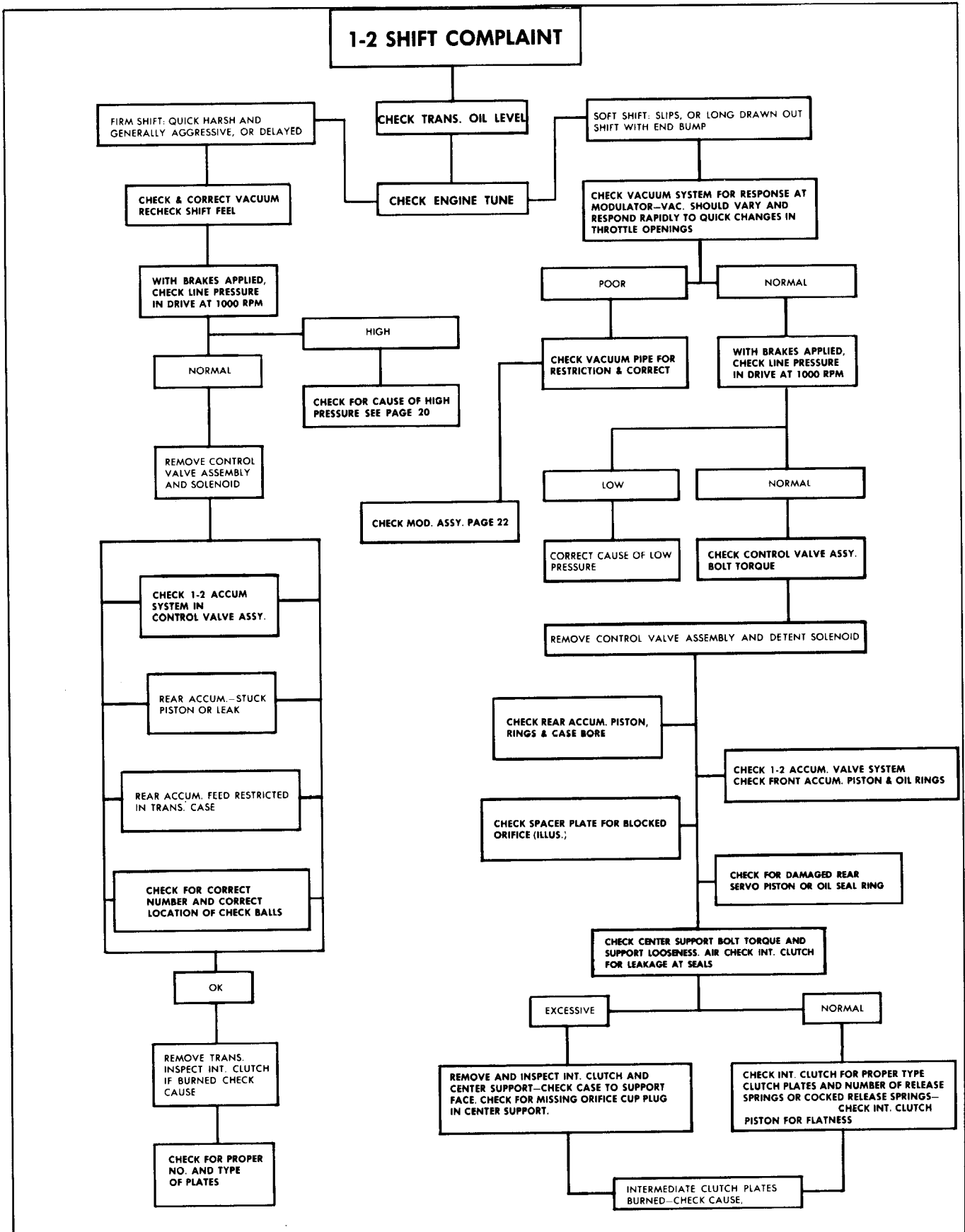

1-2 Shift Complaint

2-3 SHIFT COMPLAINT

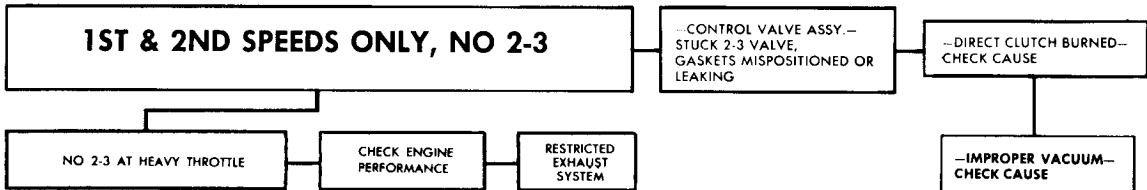
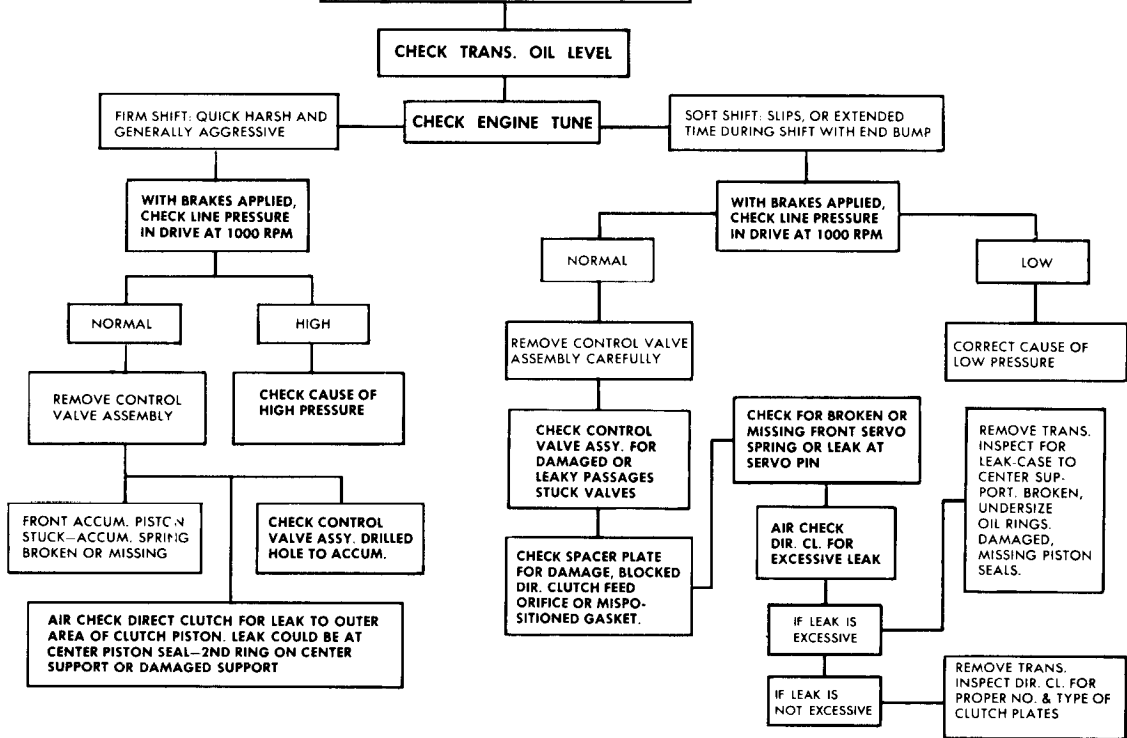

NO DETENT DOWNSHIFTS

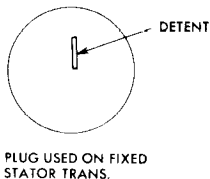
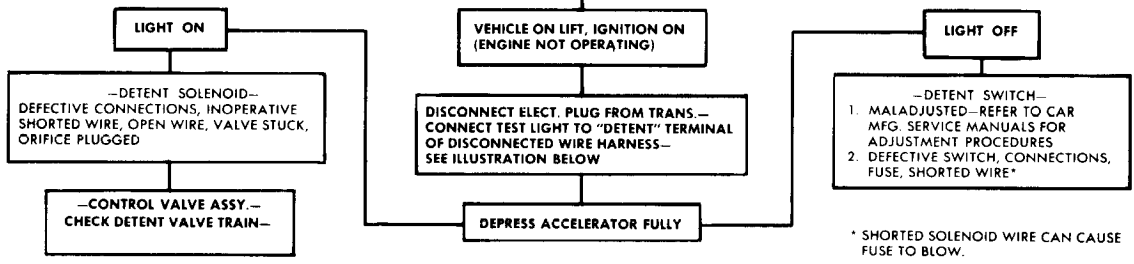

* SHORTED SOLENOID WIRE CAN CAUSE FUSE TO BLOW.

2-3 Shift, 1st 2nd Speeds, No Detent

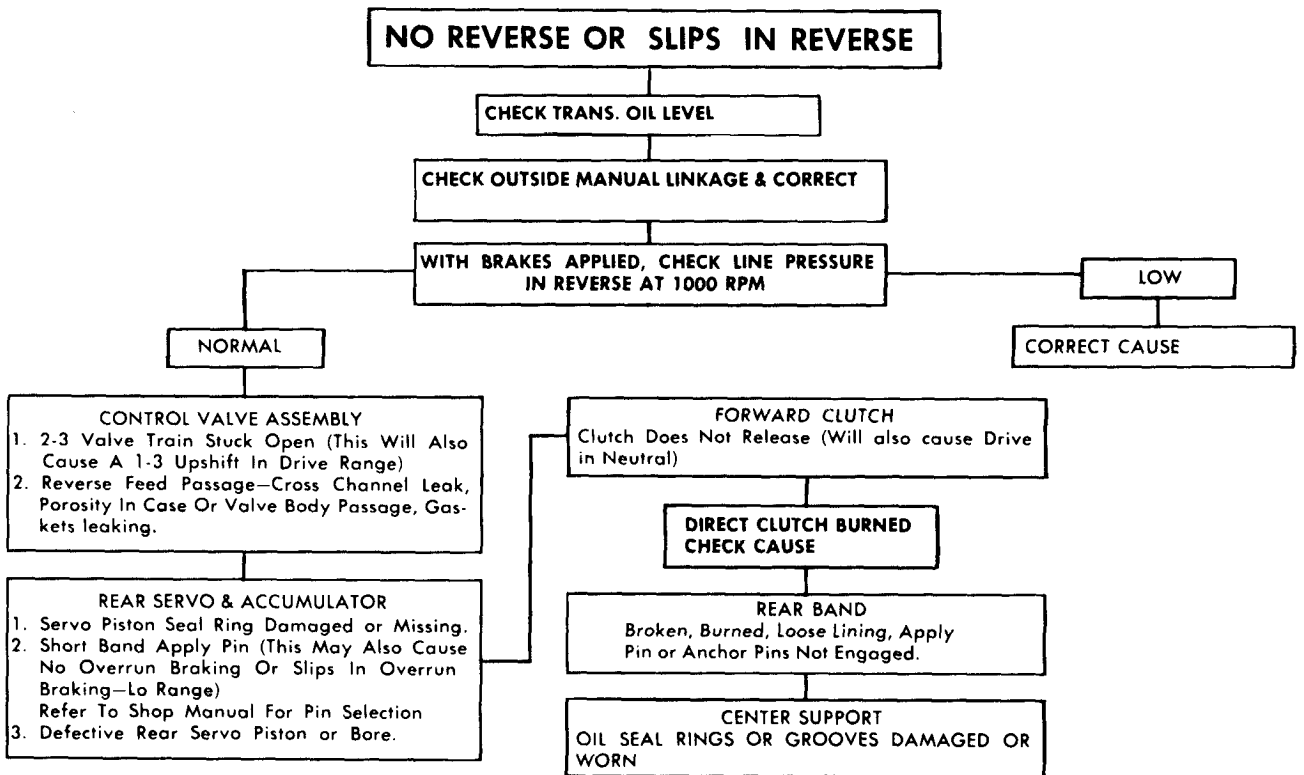
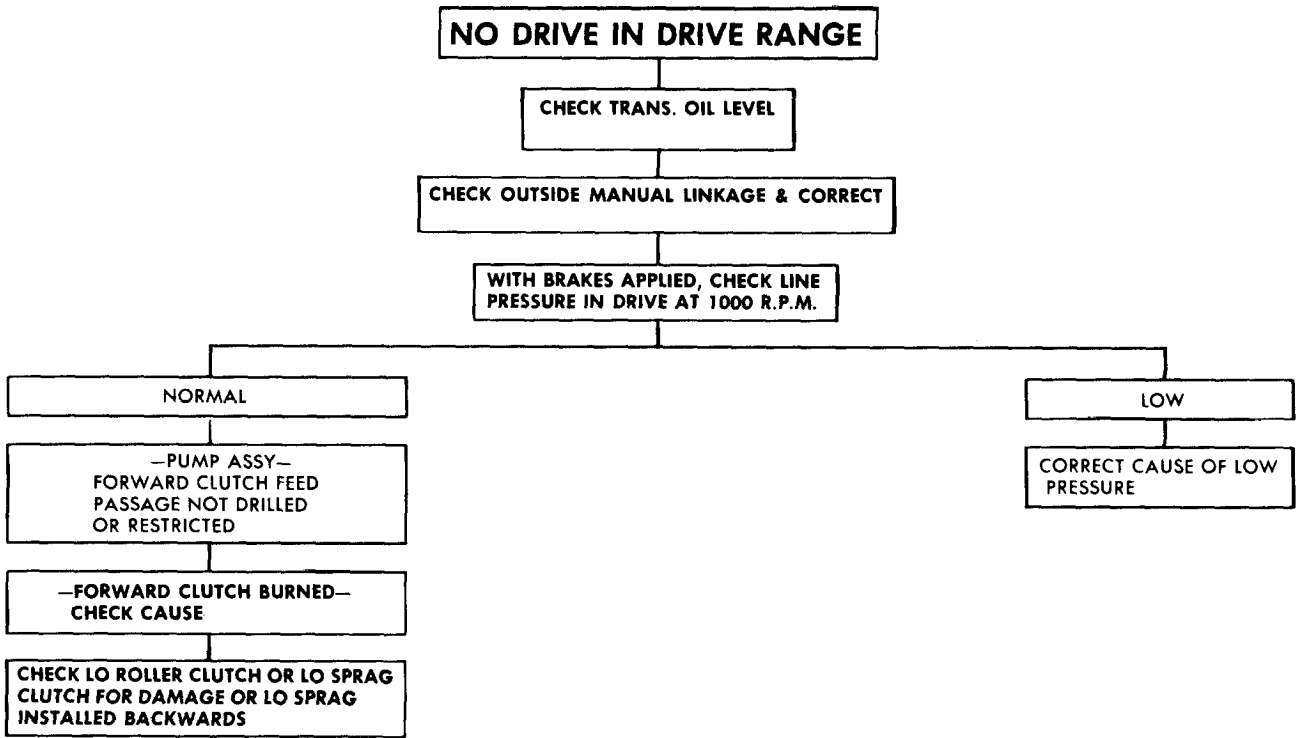

No Drive, No Reverse

NO ENGINE BRAKING—INTERMEDIATE RANGE—SECOND GEAR

—FRONT SERVO & ACCUMULATOR—
OIL RINGS AND/OR BORES LEAKING OR
FRONT SERVO PISTON COCKED OR STUCK

INCORRECT COMBINATION OF FRONT
SERVO AND ACCUMULATOR PARTS.

—FRONT BAND—
BROKEN, BURNED (CHECK FOR CAUSE), NOT
ENGAGED ON ANCHOR PIN AND/OR
SERVO PIN.

DRIVE IN NEUTRAL

CHECK OUTSIDE MANUAL LINKAGE & CORRECT

—INTERNAL LINKAGE—
MANUAL VALVE DISCONNECTED OR END
BROKEN, INSIDE DETENT LEVER PIN BROKEN.

—PUMP ASSEMBLY—
TRANS. LUBE PRESSURE LEAKING INTO
FORWARD CLUTCH APPLY PASSAGE.

—FORWARD CLUTCH—
BURNED PLATES—CHECK CAUSE
INCORRECT CLUTCH PLATE USAGE

**NO ENGINE BRAKING— LO RANGE—
1ST GEAR**

—CASE ASSEMBLY—
LO—REVERSE CHECK BALL MISPOSITIONED OR
MISSING. CASE DAMAGED AT LO—REVERSE
CHECK BALL AREA.

—REAR SERVO—
OIL SEAL RING, BORE OR PISTON DAMAGED
REAR BAND APPLY PIN SHORT,
IMPROPERLY ASSEMBLED

—REAR BAND—
BROKEN, BURNED (CHECK FOR CAUSE), NOT
ENGAGED ON ANCHOR PINS AND/OR
SERVO PIN.

**WON'T HOLD IN PARK OR WON'T
RELEASE FROM PARK**

CHECK OUTSIDE MANUAL LINKAGE & CORRECT

—INTERNAL LINKAGE—

1. Parking Brake Rod Assy. (Check Actuator For Chamfer)
2. Parking Pawl Broken, Chamfer Omitted.
3. Parking Brake Bracket Loose, Burr Or Rough Edges, or Incorrectly Installed.
4. Parking Pawl Return Spring Missing, Broken or Incorrectly Hooked.

CAUTION: BEFORE CHECKING TRANSMISSION FOR WHAT IS BELIEVED TO BE "TRANS. NOISE," MAKE CERTAIN THE NOISE IS NOT FROM THE WATER PUMP, ALTERNATOR, AIR CONDITIONER, POWER STEERING, ETC. THESE COMPONENTS CAN BE ISOLATED BY REMOVING THE PROPER BELT AND RUNNING THE ENGINE NOT MORE THAN TWO MINUTES AT ONE TIME.

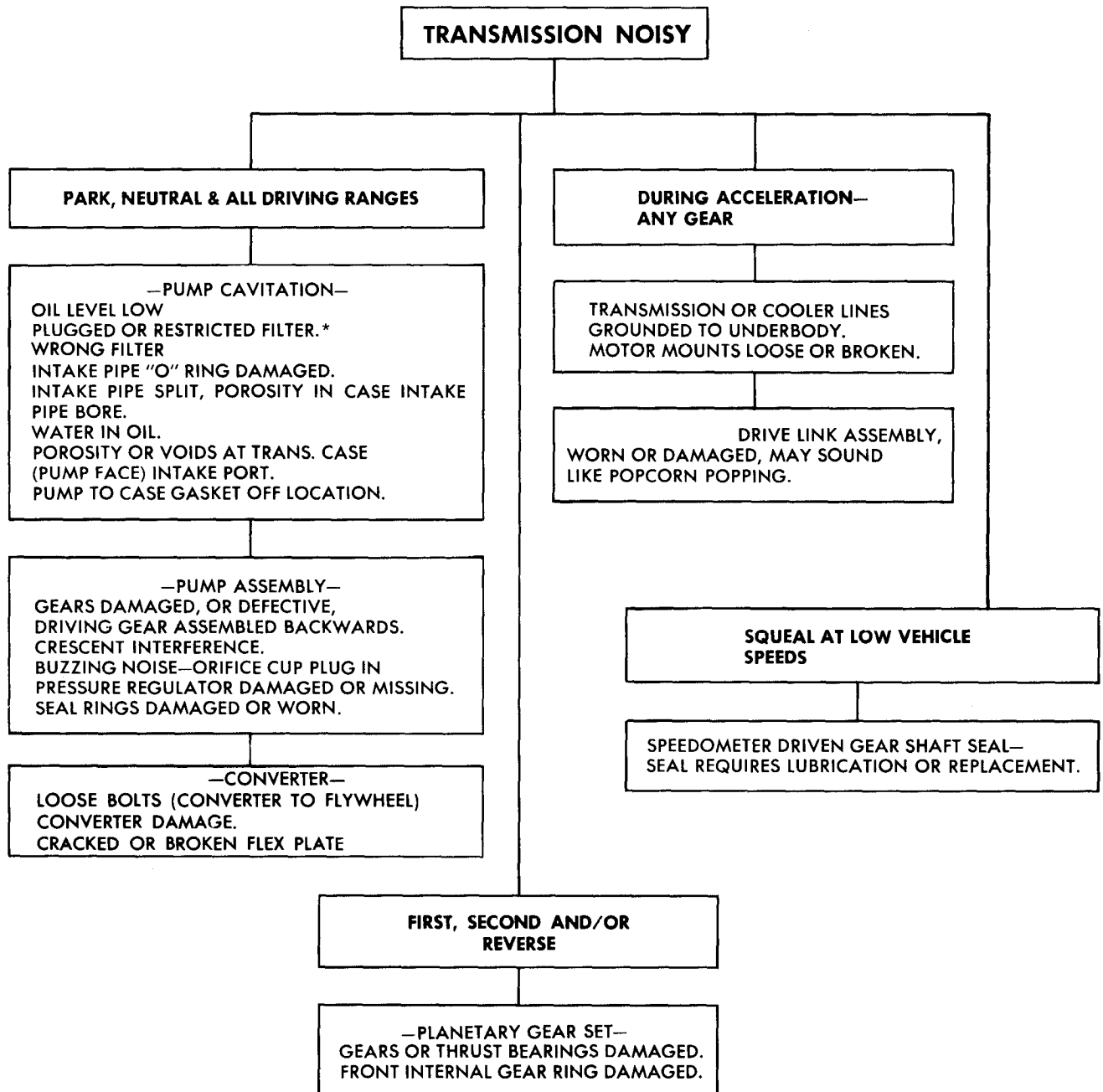

* There is no approved way of checking or cleaning the filter. If the filter is suspected of being plugged or restricted, it must be replaced.

LO RANGE:

Position the selector lever in **LO RANGE** and accelerate the vehicle from 0 mph. No upshift should occur in this range, except in some vehicles which have a high numerical axle ratio and/or high engine rpm.

2ND GEAR - OVERRUN BRAKING:

Position the selector lever in **DRIVE RANGE**, and with the vehicle speed at approximately 35 mph, move the selector lever to **SUPER RANGE**. The transmission should downshift to 2nd. An increase in engine rpm and an engine braking effect should be noticed. Line pressure should change from approximately 70 psi to approximately 150 psi in 2nd.

1st GEAR - OVERRUN BRAKING:

Position the selector lever in **SUPER RANGE** at approximately 30 to 40 mph, with throttle closed, move the selector lever to **Lo**. A 2-1 downshift should occur in the speed range of approximately 40 to 20 mph, depending on axle ratio and valve body calibration. The 2-1 downshift at closed throttle will be accompanied by increased engine rpm and an engine braking effect should be noticed. Line pressure should be approximately 150 psi. Stop vehicle.

REVERSE RANGE:

Position the selector lever in **REVERSE POSITION** and check for reverse operation.

CAUSES OF LOW LINE PRESSURE

1. Low Transmission Oil Level.
2. Modulator Assembly
3. Filter.
 - a. Blocked or restricted.*
 - b. "O" Ring on intake pipe and/or grommet omitted or damaged.
 - c. Split or leaking intake pipe.

d. Wrong filter assembly.

4. Pump.

a. Pressure regulator or boost valve stuck.

b. Gear clearance, damaged worn. (Pump will become damaged if drive gear is installed backwards, or if converter pilot does not enter crankshaft freely).

c. Pressure regulator spring, too weak.

d. Not enough spacers in pressure regulator.

e. Pump to case gasket mispositioned.

f. Defective pump body and/or cover.

g. Mismatch pump cover/pump body.

5. Internal Circuit Leaks.

a. Forward clutch leak (pressure normal in neutral and reverse-pressure low in drive).

1. Check pump rings.

2. Check forward clutch seals.

b. Direct clutch leak (pressure normal in neutral, low, intermediate, and drive-pressure low in reverse).

1. Check center support oil seal rings.

2. Check direct clutch outer seal for damage.

3. Check rear servo and front accumulator pistons and rings for damage or missing.

6. Case Assembly.

a. Porosity in intake bore area.

b. Check case for intermediate clutch plug leak or blown out.

c. Lo-reverse check ball mispositioned or missing (this will cause no reverse and no overrun braking in Lo range).

*There is no approved service procedure for checking or cleaning the filter. If the filter is suspected of being plugged or restricted, it must be replaced.

CAUSES OF HIGH LINE PRESSURE

1. Vacuum Leak.

- a. Full leak (vacuum line disconnected).
- b. Partial leak in line from engine modulator.
- c. Improper engine vacuum.
- d. Vacuum operated accessory leak. (Hoses, vacuum advance, etc.).

2. Damaged Modulator.

- a. Stuck valve.
- b. Water in modulator.
- c. Not operating properly.

3. Detent System.

- a. Detent switch actuated (plunger stuck) or shorted.
- b. Detent wiring shorted.
- c. Detent solenoid stuck open.
- d. Detent feed orifice in spacer plate blocked.
- e. Detent solenoid loose.
- f. Detent valve bore plug damaged.
- g. Detent regulator valve pin short.

4. Pump.

- a. Pressure regulator and/or boost valve stuck.
- b. Incorrect pressure regulator spring.
- c. Too many pressure regulator valve spacers.
- d. Pump casting bad.
- e. Pressure boost valve installed backwards or defective.
- f. Aluminium bore plug has hole or otherwise defective.
- g. Pressure boost bushing broken or otherwise defective.

5. Control Valve Assembly.

- a. Spacer plate-to-case gasket off location.
- b. Wrong spacer plate-to-case gasket.

CAUSES OF IMPROPER VACUUM AT MODULATOR

1. Engine.

- a. Requires tune up.

- b. Loose vacuum fittings.

- c. Vacuum operated accessory leak (hoses, vacuum advance, etc.)

2. Vacuum Line to Modulator.

- a. Leak.

- b. Loose fitting.

- c. Restricted orifice, or incorrect orifice size.

- d. Carbon build up at modulator vacuum fitting.

- e. Pinched line.

- f. Grease or varnish material in pipe (no or delayed up-shift-cold).

CONTROL VALVE ASSEMBLY- GOVERNOR LINE PRESSURE CHECK

1. Install line pressure gage.

2. Disconnect vacuum line to modulator.

3. With vehicle on hoist (front wheels off ground), foot off brake, in drive, check line pressure at 1000 rpm.

4. Slowly increase engine rpm to 3000 rpm and determine if a line drop occurs (7 psi or more).

5. If pressure drop occurs, disassemble, clean and inspect control valve assembly.

6. If no pressure drop occurs:

- a. Inspect governor.

1. Stuck valve.

2. Weight freeness.

3. Restricted orifice in governor valve.

b. Governor feed system.

1. Check screen in governor feed pipe hole in case assembly.

2. Check for restrictions in governor pipe.

CAUSES OF BURNED CLUTCH PLATES

NOTE: Burned clutch plates can be caused by incorrect usage of clutch plates. Also, anti-freeze in transmission fluid can cause severe damage, such as large pieces of composition clutch material peeling off.

1. Forward Clutch.

a. Check ball in clutch housing damaged, stuck or missing.

b. Clutch piston cracked, seals damaged or missing.

c. Low line pressure.

d. Manual valve mispositioned.

e. Restricted oil feed to forward clutch (Examples: Clutch housing to inner and outer areas not drilled, restricted or porosity in pump).

f. Pump cover oil seal rings missing, broken or undersize; ring groove oversize.

g. Case valve body face not flat or porosity between channels.

h. Manual valve bent and center land not ground properly.

2. Intermediate Clutch.

a. Rear accumulator piston oil ring, damaged or missing.

b. 1-2 accumulator valve stuck in control valve assembly.

c. Intermediate clutch piston seals damaged or missing.

d. Center support bolt loose.

e. Low line pressure.

f. Intermediate clutch plug in case missing.

g. Case valve body face not flat or porosity between channels.

h. Manual valve bent and center land not ground properly.

3. Direct Clutch.

a. Restricted orifice in vacuum line to modulator (poor vacuum response.)

b. Check ball in direct clutch piston damaged, stuck or missing.

c. Defective Modulator bellows.

d. Center support bolt loose. (Bolt may be tight in support but not holding support tight to case).

e. Center support oil rings or grooves damaged or missing.

f. Clutch piston seals damaged or missing.

g. Front and rear servo pistons and seals damaged.

h. Manual valve bent and center land not cleaned up.

i. Case valve body face not flat or porosity between channels.

j. Intermediate roller clutch installed backwards.

k. 3-2 valve, 3-2 spring or 3-2 spacer pin installed in wrong location in 3-2 valve bore.

NOTE: If direct clutch plates and front band are burned, check manual linkage.

VACUUM MODULATOR ASSEMBLY

The following procedure is recommended for checking Turbo Hydra-matic modulator assemblies in the field before replacement is accomplished.

1. Vacuum Diaphragm Leak Check. Insert a pipe cleaner into the vacuum connector pipe as far as possible and check for the presence of transmission oil. If oil is found, replace the modulator.

CAUTION: Gasoline or water vapor may settle in the vacuum side of the modulator. If this is found without the presence of oil, the modulator should not be changed.

2. Atmospheric Leak Check. Using Hand Vacuum Pump, such as J-23738, apply 20" HG to

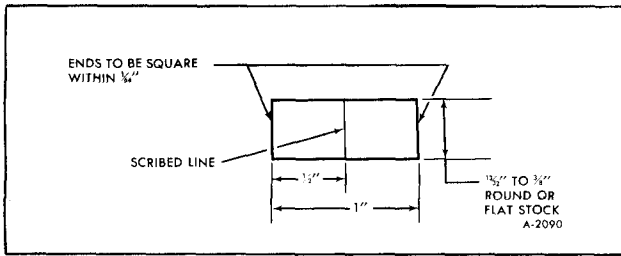

Figure 24—Vacuum Modulator Test Gage

diaphragm. Modulator should hold vacuum for 10 seconds. If vacuum drops, replace modulator.

3. **Bellows Comparison Check.** Make a comparison gage, as shown in Figure 24, and compare the load of a known good Hydra-matic modulator with the assembly in question. Modulator Tension Tester such as J-24466 may also be used for this purpose.

a. Install the modulator that is known to be acceptable on either end of the gage.

b. Install the modulator in question on the opposite end of the gage.

c. Holding the modulators in a horizontal position, bring them together under pressure until either modulator sleeve end just touches the line in the center of the gage. The gap between the opposite modulator sleeve end and the gage line should then be $1/16$ " or less. If the distance is greater than this amount, the modulator in question should be replaced.

4. **Sleeve Alignment Check.** Roll the main body of the modulator on a flat surface and observe the sleeve for concentricity to the can. If the sleeve is concentric and the plunger is free, the modulator is acceptable.

Once the modulator assembly passes all of the above tests, it is an acceptable part and should be re-used.

DOWNSHIFT SOLENOID CIRCUIT CHECK

NOTE: Before checking the downshift solenoid circuitry, make certain that the transmission downshift switch is properly adjusted.

1. With transmission shift lever in Park, turn ignition switch to "ON" position, but do not start vehicle. Leave ignition switch "ON" throughout checking procedure.

2. With the engine cover removed, slowly ad-

vance throttle linkage to wide open position. One click should be heard from transmission.

3. Allow throttle to return to closed position. One click should be heard from transmission.

4. If system performed as described above, downshift circuit is operating properly. If system does not perform as described above, proceed to step 5.

5. Use test light to check orange wire at connector on side of transmission case. Test light should light with throttle wide open and go out when throttle is released.

a. If system operates as described above, but did not perform properly during steps 1-3, replace solenoid after first checking to see that internal wiring is operational.

b. If light fails to light with throttle in wide open position, the circuit is open, proceed to step 6.

c. If light lights with throttle closed, the circuit is shorted. Proceed to step 9.

6. At transmission downshift switch, use test light to check from the top terminal at switch with throttle wide open.

a. If test light lights, recheck system.

b. If test light fails to light, proceed to step 7.

7. Check lower feed wire at transmission downshift switch with test light.

a. If test light lights, replace transmission downshift switch. Recheck system.

b. If test light fails to light, proceed to step 8.

8. Check 10 amp. (gages and transmission control fuse) in fuse panel.

a. If necessary to replace fuse, recheck system.

b. If fuse is all right, it will be necessary to locate the open in the wiring. Test the circuit continuity from the lower wire at the downshift switch to the battery.

9. At the transmission downshift switch, use test light to check from the disconnected top terminal at switch with throttle closed.

a. If test light fails to light, orange wire is shorted. Correct shorting condition.

b. If test light lights, proceed to step 10.

10. With throttle in closed position, check lower feed wire at transmission downshift switch.

a. If test light fails to light, replace transmission downshift switch. Recheck system.

b. If test light lights, it will be necessary to locate the short in the wiring. Test the circuit from the lower wire at the downshift switch to the battery.

CLUTCH PARTS

Clutch	No. of Flat Steel Clutch Plates	No. of Waved Steel Clutch Plates
Forward Clutch.....	5	1
Direct Clutch.....	5	1
Intermediate Clutch.....	3	-

Clutch Plate Dished

Clutch	No. of Clutch Composition Plates	No. of Piston Release Springs
Forward Clutch.....	5	16
Direct Clutch.....	6	14
Intermediate Clutch.....	3	6

ON VEHICLE SERVICING

FLUSHING OIL COOLER

The oil cooler is located in the side tank of the radiator and its purpose is to cool the oil in the event excessive temperature tends to develop. (figure 25)

In a major transmission failure, where particles of metal have been carried with the oil throughout the units of the transmission. It will be necessary to flush out the oil cooler and connecting lines. The oil cooler is a sealed container providing a passage for oil to flow from the inlet to the outlet. Clean solvent can be flushed through the cooler with air pressure. (An engine desludge gun may be used.) The cooler should be back-flushed first through the return line to remove all foreign material possible. Then flush through the inlet line and finish by flushing through the return line. Clean remaining solvent from cooler with compressed air applied to the return line and flush with transmission fluid.

LINKAGE ADJUSTMENT (FIGURE 26)

CAUTION: *Block vehicle wheels and apply*

parking brake before attempting transmission linkage adjustment.

1. Place steering column shift lever in neutral against stop in column, (a detent will hold it there).
2. Loosen relay rod clamp screw.
3. Position range selector lever in the neutral detent position.

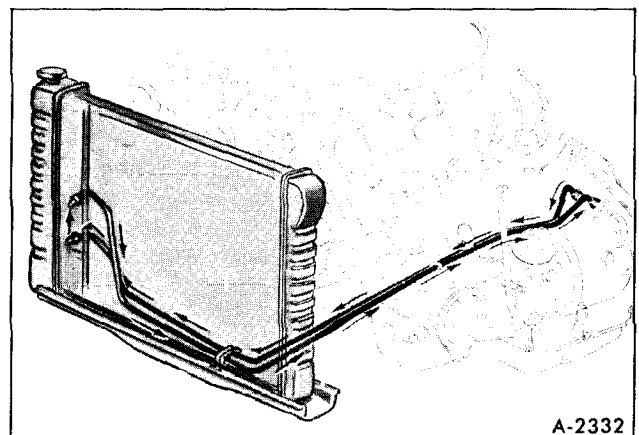

Figure 25—Oil Cooler and Lines

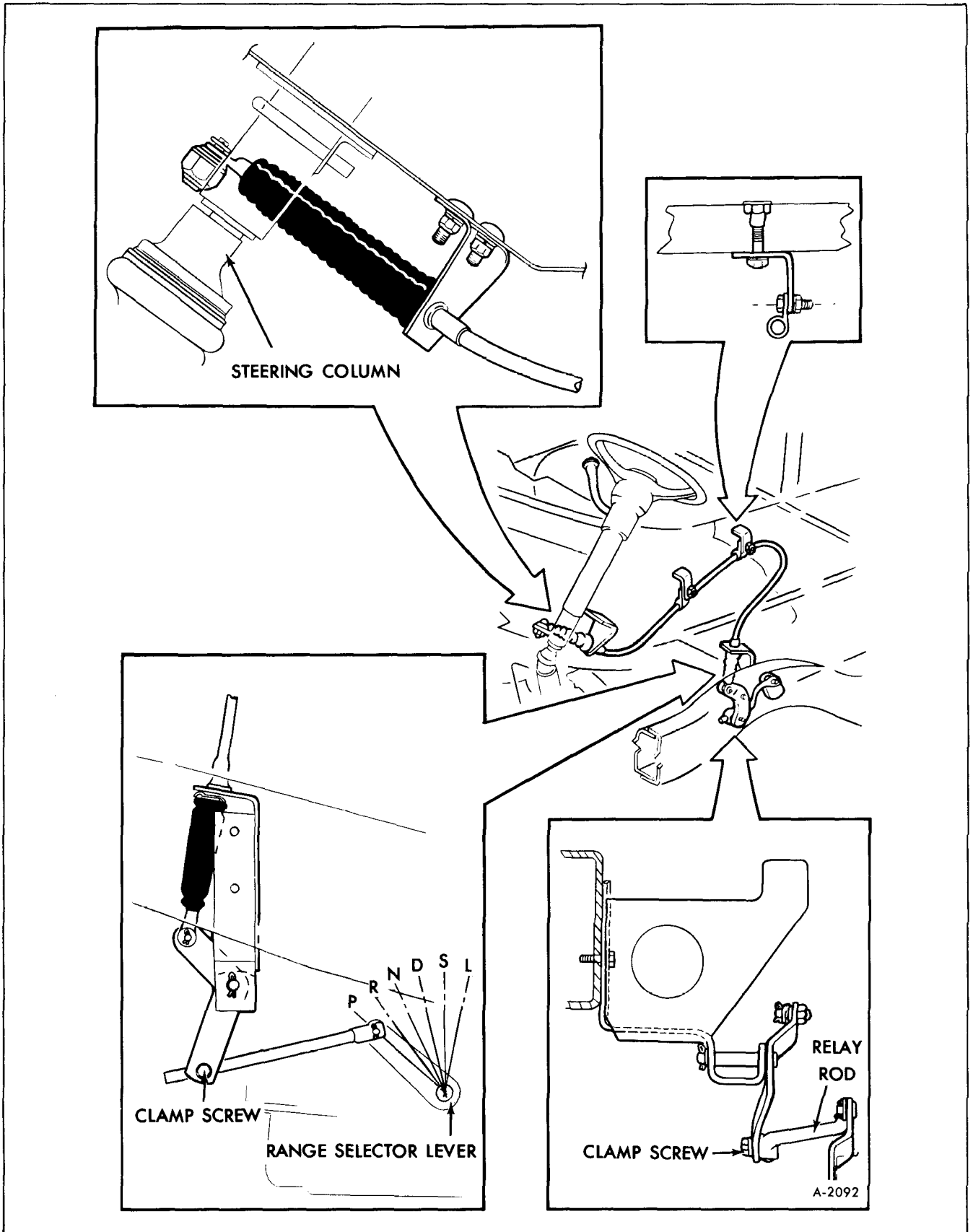

Figure 26-Transmission Manual Linkage

4. Tighten relay rod clamp screw to 20 ft. lbs., making sure shift lever is held against Neutral stop while this operation is being performed.

5. Check operation of selector lever by performing the following steps:

a. Lift lever and move to Neutral detent. (This is the detent in the transmission.) Release the lever and check to make sure that the lever fits into the neutral notch in the steering column.

b. Move lever to Drive detent. There should be a slight travel of the lever beyond this detent until the drive stop in the steering column is reached.

c. Move lever to Reverse detent and check as in b above.

6. Check for proper operation of neutral safety switch and back-up lights, (be sure vehicle has positive "PARK" engagement and "L" range engagement). When parking on a hill, refer to additional details on PARKING BRAKE in Operating Manual.

DOWNSHIFT SWITCH ADJUSTMENT

The procedure for adjusting the downshift switch is described in SECTION 6M under "Accelerator Control".

CHECKING AND ADDING FLUID

NOTE: Vehicle level and oil temperature are particularly important when checking fluid level on a Turbo Hydra-matic transmission. Careful attention to the following procedures is necessary in order to determine the actual fluid level.

Oil Recommendations

Whenever fluid is added to the transmission use only DEXRON type transmission fluid, or fluids of equivalent quality that have been especially formulated and tested for use in the Turbo Hydra-matic transmission.

Oil Level

The transmission dipstick and filler tube is located under the engine access cover at the left center side of the engine. The "FULL" and "ADD" dimple marks on the transmission dipstick indicate one pint difference. Correct fluid level is determined at normal engine coolant operating temperature (180°F-190°F). Careful attention to transmission oil

temperature is necessary, as proper fluid level at low operating temperatures will be below the "ADD" mark on the dipstick, Figure 27, and proper fluid level at higher operating temperatures will rise above the "FULL" mark. Fluid level must always be checked with the vehicle on level surface, and with engine running to make certain converter is full. To determine proper fluid level, proceed as follows:

NOTE: The full mark on the dipstick is an indication of transmission fluid at normal operating temperature of 170°. This temperature is only obtained after several miles of stop-and-go driving.

1. With manual control lever in Park position start engine. **DO NOT RACE ENGINE.** Move manual control lever through each range.

2. Immediately check fluid level with selector lever in Park, engine running, and vehicle on LEVEL surface.

At this point, when a reading is made, fluid level on the dipstick should be between the add and full mark.

3. If additional fluid is required, add fluid to raise the level between the add and full mark.

If vehicle is not driven 15 expressway miles or equivalent, and it becomes necessary to check fluid level, the transmission fluid must be at room temperature (approximately 70°F.).

With fluid at room temperature follow steps 1, 2 and 3 below.

1. With manual control lever in Park position start engine. **DO NOT RACE ENGINE.** Move manual control lever through each range.

2. Immediately check fluid level with selector lever in Park, engine running, and vehicle on LEVEL surface.

At this point, when a reading is made, fluid level on the dipstick should be 1/4" below the "ADD" mark.

3. If additional fluid is required add fluid to bring level to 1/4" below the "ADD" mark on the dipstick.

CAUTION: Do not overfill, as forming and loss of fluid through the vent pipe might occur as fluid heats up. If fluid is too low, especially when cold, complete loss of drive may result which can cause transmission failure.

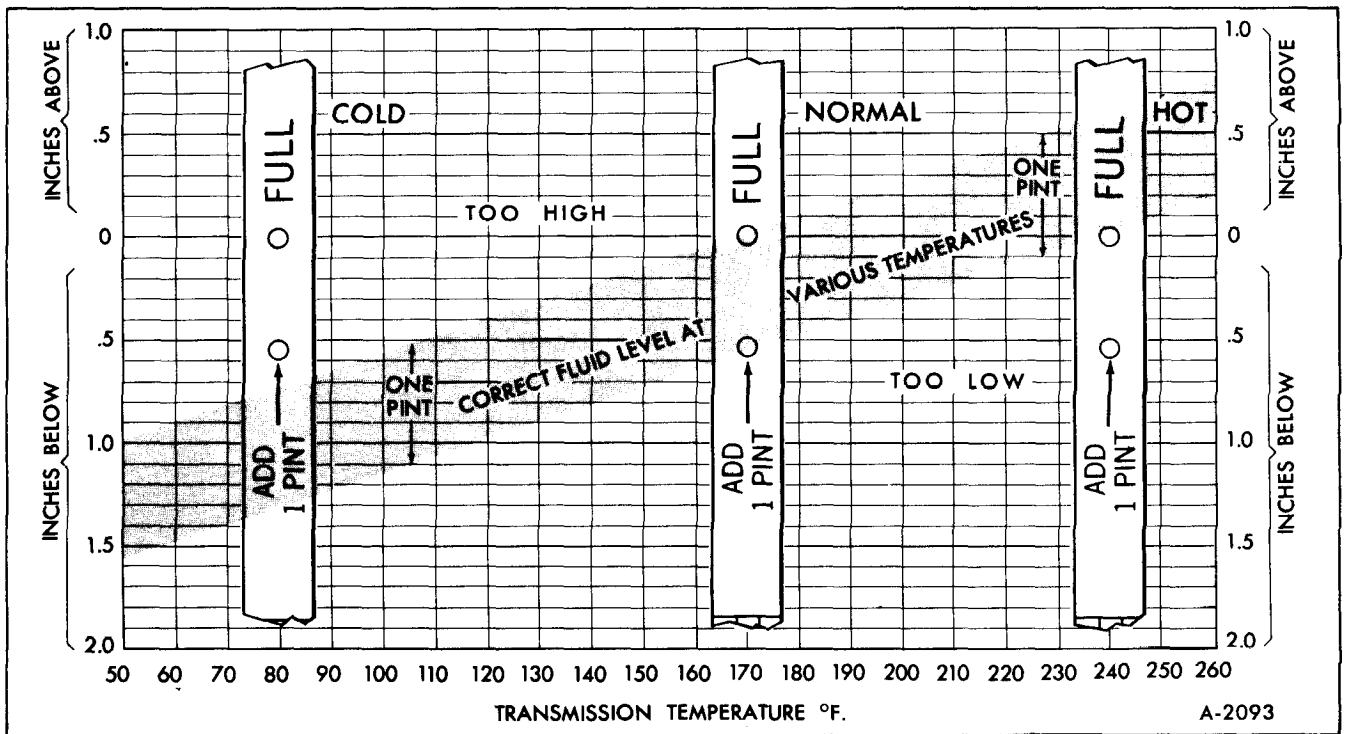

Figure 27—Transmission Oil Level

NOTE: If transmission fluid level is correctly established at 70°F. (.9" below full) it will appear at the "FULL" mark on the dipstick when the transmission reaches normal operating temperature (170°F.). When cold the fluid level is set 1/4" below the "ADD" mark on the dipstick to allow for expansion of the fluid which occurs as transmission temperatures rise to normal operating temperature of 170°F.

Draining Bottom Pan and Replacing Intake Pipe and Filter Assembly

To drain bottom pan only, eliminate steps 5 and 6.

1. Remove dipstick from filler tube and insert a length of hose secured to a suction gun down the dipstick. Remove enough transmission fluid so that bottom pan will not overflow when removed.

2. Raise vehicle on hoist or place on jack stands, and provide container to collect draining oil.

3. Remove bottom pan and gasket. Discard gasket.

4. Drain fluid from bottom pan. Clean pan with solvent and dry thoroughly with clean compressed air.

5. Remove intake pipe and filter assembly. Remove and discard intake pipe O-ring.

6. Install new intake pipe O-ring into pipe bore in transmission case and install new intake pipe and filter assembly.

7. Install new gasket on bottom pan and install bottom pan. Tighten bottom pan attaching screws to 12 foot-pounds.

8. Lower vehicle and add five quarts of transmission fluid through filler tube when replacing intake pipe and filter assembly. When draining bottom pan only, add four quarts of transmission fluid.

9. Operate engine at 800 rpm for approximately 1-1/2 minutes with selector lever in park "P" position.

10. Reduce engine speed to slow idle and check fluid level. Add fluid to bring to proper level, Figure 27.

Adding Fluid to Dry Transmission and Converter Assembly

The fluid capacity of the Turbo Hydra-matic transmission and converter assembly is approximately 13 quarts, but correct level is determined by

mark on dipstick rather than by amount added. It is important that proper level be maintained. In cases of transmission overhaul, when a complete fill is required, including converter, proceed as follows:

1. Add 9 quarts of transmission fluid through filler tube.
2. Operate engine at 800 rpm for approximately 1-1/2 minutes with selector lever in park "P" position.
3. Reduce engine speed to slow idle.
4. Check fluid level and add additional fluid to bring to proper level, Figure 27.

Sprocket Housing Cover Removal

If the sprocket housing cover is removed, add transmission oil as described under "OIL LEVEL".

TOWING INSTRUCTIONS

Refer to SECTION 0 for towing instructions.

UNITS THAT CAN BE REMOVED WITH TRANSMISSION IN VEHICLE

The following units can be removed from the

transmission without removing transmission from vehicle.

While the detailed procedure for removing each of the units is not outlined separately, the procedures covered under the transmission disassembly and assembly will apply.

1. Oil pan and pan to case gasket.
2. Pressure regulator valve assembly.
3. Valve body assembly.
4. Rear servo and accumulator assembly.
5. Front servo and accumulator assembly.
6. Governor pipes.
7. Detent solenoid.
8. Solenoid connector.
9. Parking linkage.
10. Valve body to case spacers and gaskets.
11. Check balls.
12. Detent roller and spring assembly.
13. Filter assembly.

TRANSMISSION REPLACEMENT

REMOVAL OF TRANSMISSION

Due to the power train configuration, it is easier to remove the transmission and final drive as an assembly. The following is the procedure to remove the transmission and final drive assembly.

1. Disconnect negative battery cables.
2. Remove engine access cover.
3. Position engine holding fixture as shown in Figure 28 and adjust mechanism to remove slack from cable.
4. Raise vehicle.
5. Disconnect starting motor wires.
6. Remove starting motor.

7. Remove flywheel cover behind starter.
8. Disconnect manual shift linkage at transmission.
9. Disconnect speedometer cable.
10. Disconnect oil cooler lines at transmission and position out of the way. Cap lines and connectors.
11. Disconnect detent wire and vacuum modulator tube.
12. Disconnect right axle shaft at output shaft flange.
13. Remove right output shaft and support assembly, (includes disconnecting radiator fan venturi ring bracket).

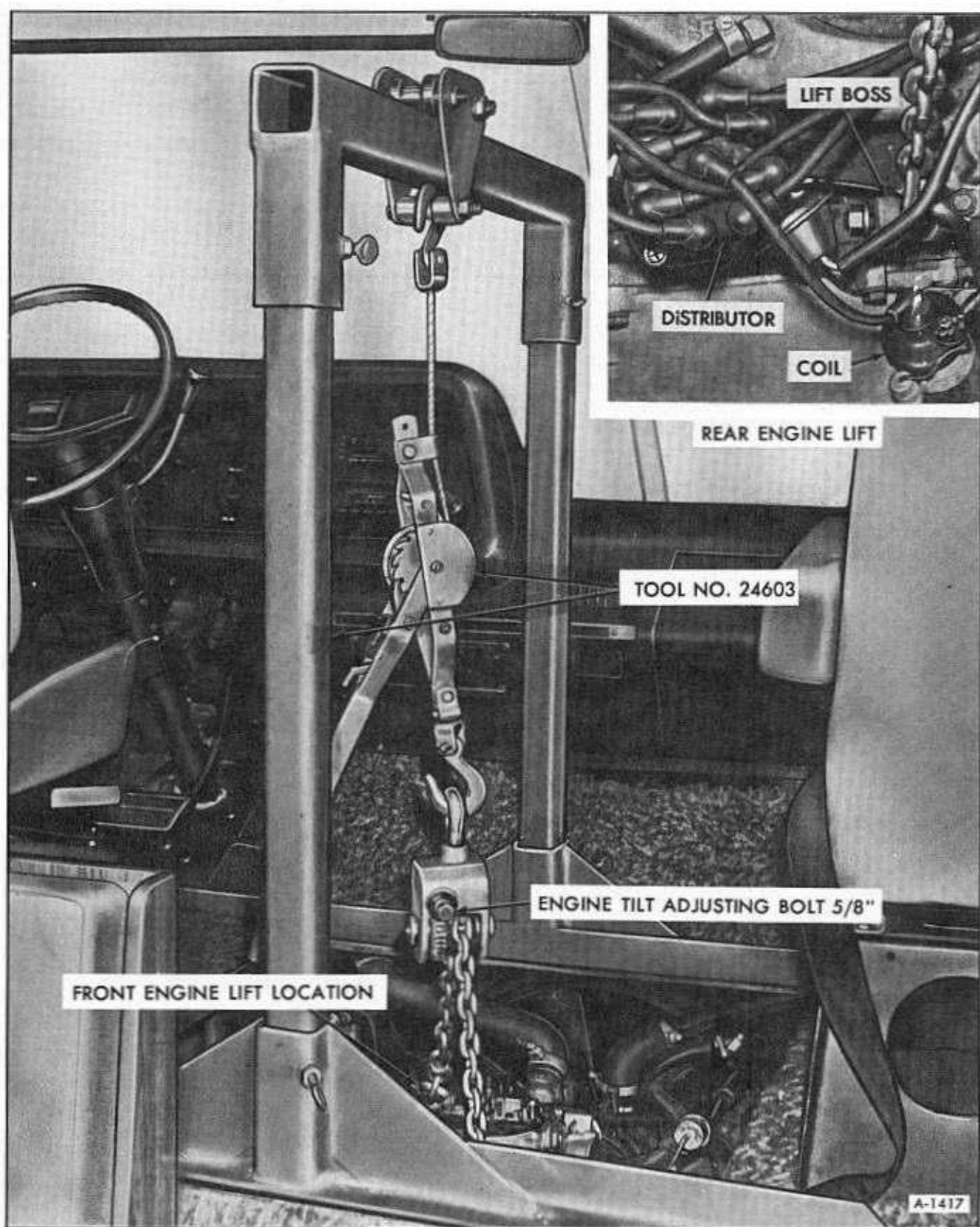

Figure 28—Engine Holding Fixture

14. Disconnect left axle shaft at left output flange.

15. Remove final drive to support bracket through bolt, washers and nut.

16. Remove three (3) converter to flywheel bolts by rotating crankshaft at harmonic balancer.

17. Remove three (3) rear support bracket to transmission bolts.

18. Remove two (2) rear motor mount to support bracket bolts.

19. Position transmission jack under transmission and secure with safety chain around transmission gear case.

20. Remove six (6) transmission converter housing to engine bolts.

21. Move transmission and final drive assembly rearward 1/2"-3/4" and lower from vehicle, installing converter holding clamp, such as J-21366, as soon as transmission is low enough.

INSTALLATION OF TRANSMISSION

1. Position transmission and final drive on jack secured with a safety chain, under the vehicle.

2. Remove converter holding clamp.

3. Raise transmission into place.

4. Loosely install top two (2) converter housing to engine bolts.

5. Slide transmission forward and engage converter pilot into flywheel.

6. Install remaining converter housing to engine bolts. Torque six (6) bolts to 30 ft. lbs.

7. Shift transmission to neutral to align weld nuts to the flywheel. Rotate the crankshaft to install three (3) attaching bolts and torque to 30 ft. lbs. (Note: Weld nuts must be flush to flywheel).

8. Remove safety chain and jack from transmission.

9. Install three (3) rear support bracket to transmission bolts. Torque to 55 ft. lbs.

10. Install two (2) rear motor mount to support bracket bolts. Torque to 55 ft. lbs.

11. Install final drive to support bracket through bolt, washers and nut. Torque bolt to 105 ft. lbs.

12. Connect left axle shaft to output flange using new bolts. Torque bolts to 65 ft. lbs.

13. Install right output shaft and support assembly and fan venturi bracket. Torque bolt to 50 ft. lbs.

14. Connect right axle shaft to output flange using new bolts. Torque bolts to 65 ft. lbs.

15. Connect detent wire and vacuum modulator tube.

16. Connect oil cooler lines. Torque fitting to 20 ft. lbs.

17. Connect speedometer cable.

18. Connect manual shift linkage using a new cotter pin.

19. Install flywheel cover behind starter. Torque bolts to 5 ft. lbs.

20. Connect wires to starting motor.

21. Install starting motor. Torque bolts to 30 ft. lbs.

22. Lower vehicle.

23. Remove engine holding fixture.

24. Connect negative battery cables.

25. Fill transmission with fluid as described under **CHECKING AND ADDING FLUID** in this SECTION.

26. Check manual linkage and adjust if necessary.

TRANSMISSION OVERHAUL

REMOVE FINAL DRIVE (FIGURE 29)

1. Remove bolt "A" and transmission dipstick and tube assembly.

2. Remove bolts "B, C, E, F and G" and nut "H". (NOTE: One bolt is omitted between nut "H" and bolt "C".)

3. Remove final drive from transmission, (about 1 quart of transmission fluid will drain).

REMOVE TORQUE CONVERTER

With transmission on portable jack, remove Converter Holding Clamp, J-21366, and then remove converter assembly from transmission by pulling converter straight out of housing.

CAUTION: Converter with oil weighs approximately 50 pounds. Be careful not to drop or damage converter when removing it.

ARRANGE TRANSMISSION FOR OVERHAUL

1. Install two 3/8 x 8 bolts with nuts into the case to engine mounting face. (figure 30)

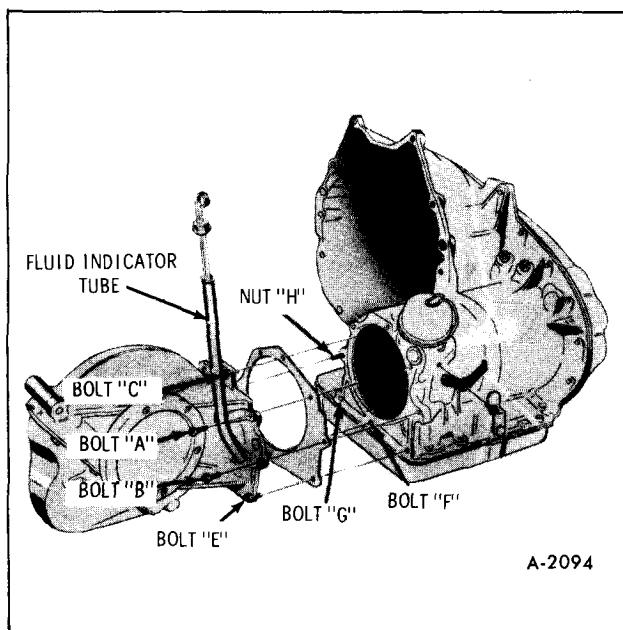

Figure 29—Final Drive Attachment

2. Remove the speedometer driven gear attaching screw and retainer clip. (figure 31)

3. Remove speedometer driven gear assembly from case bore. Remove and discard "O" ring seal.

4. Remove the governor attaching bail wire.

5. Remove governor assembly and "O" ring seal from case bore. (figure 32)

6. Remove stud from output end of case and place a piece of plywood under output end of case, place transmission on work bench with bottom pan facing the outside edge of work bench. (Let pan overhang edge of bench.) Stand transmission on the two eight inch bolts and the output flange end of the transmission case. (figure 33)

REMOVE VACUUM MODULATOR AND VALVE

NOTE: Unit may be removed without removing transmission or bottom pan, after removing vacuum hose.

1. Remove vacuum modulator attaching screw and retainer from transmission case.

2. Remove modulator assembly and O-ring from transmission case. Remove and discard O-ring from vacuum modulator, Figure 34.

3. Remove modulator valve from transmission case.

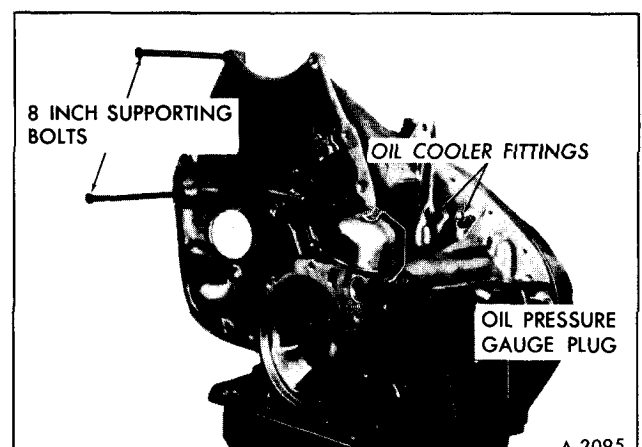

Figure 30—Transmission Support Bolts

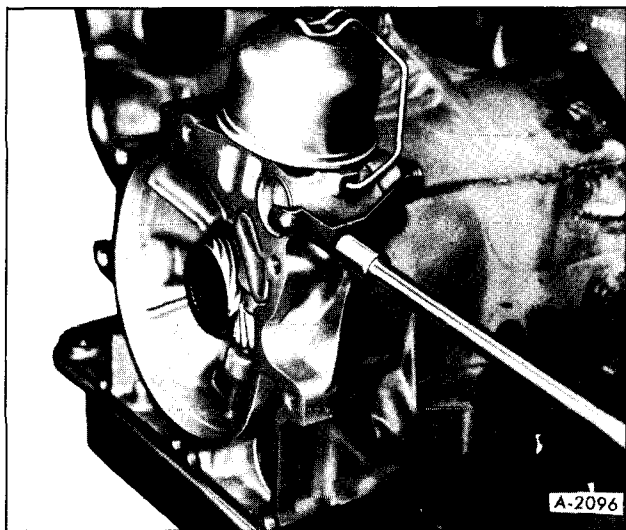

Figure 31—Removing Speedometer Driven Gear Retainer

NOTE: Modulator bushing is a snug fit in transmission case and should not be removed forcibly unless it is damaged, scored, or otherwise deformed.

REMOVE INTAKE PIPE AND FILTER ASSEMBLY AND BOTTOM PAN

NOTE: Units may be removed with transmission in vehicle. In cases of transmission failure, intake pipe and filter must be replaced.

1. Remove thirteen bottom pan attaching screws.



Figure 32—Governor Removal

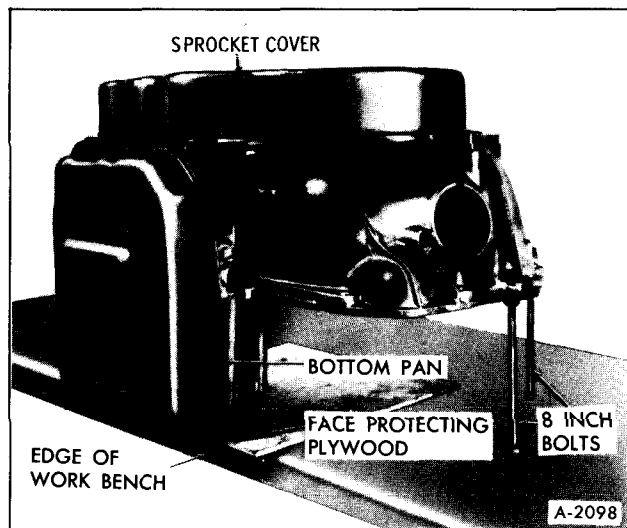

Figure 33—Arrangement of Transmission on Bench

2. Remove bottom pan and discard gasket.
3. Remove oil filter assembly.
4. Remove and discard the intake pipe to case "O" ring seal from the oil filter assembly or from the case counterbore.

REMOVE PRESSURE REGULATOR VALVE

NOTE: Unit may be removed with transmission in vehicle after removing bottom pan.

1. Compress regulator boost valve bushing against pressure regulator spring and remove snap

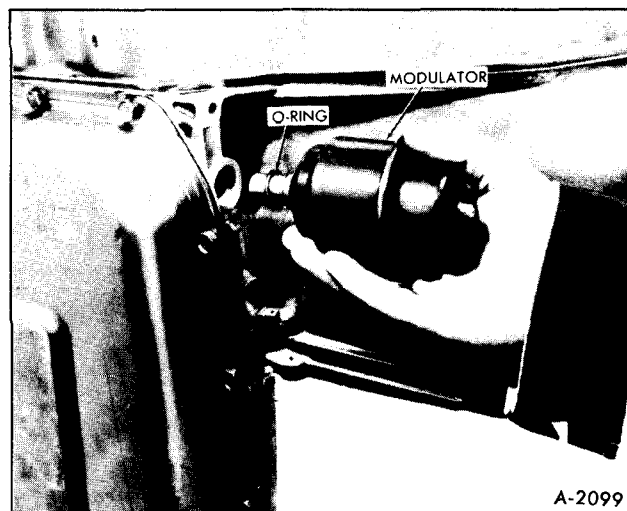

Figure 34—Removing Vacuum Modulator

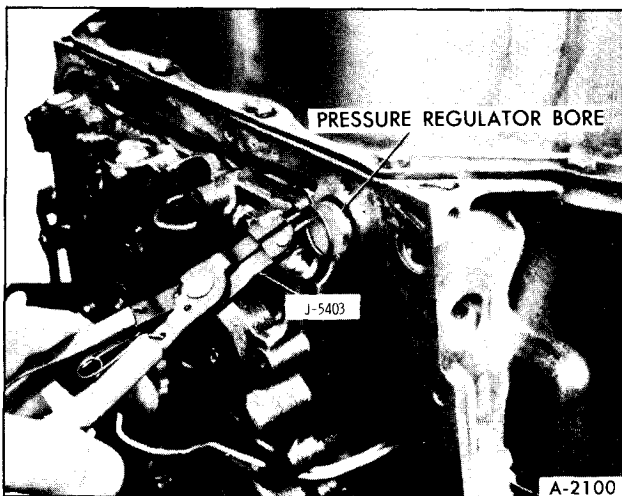

Figure 35—Removing Pressure Regulator Valve

ring using Snap Ring Pliers, J-5403 (#21), Figure 35.

WARNING: PRESSURE REGULATOR SPRING IS UNDER CONSIDERABLE COMPRESSION.

2. Remove regulator boost valve bushing and valve.
3. Remove pressure regulator spring.
4. Remove regulator valve, spring retainer, and spacer or spacers if present.

REMOVE CONTROL VALVE ASSEMBLY, GOVERNOR PIPES, DETENT SPRING, AND ROLLER ASSEMBLY, AND CHECK BALLS

NOTE: Units may be removed with transmission in vehicle, after removing bottom pan.

1. Remove attaching screw and remove detent roller and spring assembly.
2. Disconnect detent wire from case connector.
3. Remove governor feed pipe from transmission case and valve body by lifting straight out.
4. Remove nineteen remaining control valve assembly attaching screws. Do not remove detent solenoid attaching screws at this time.

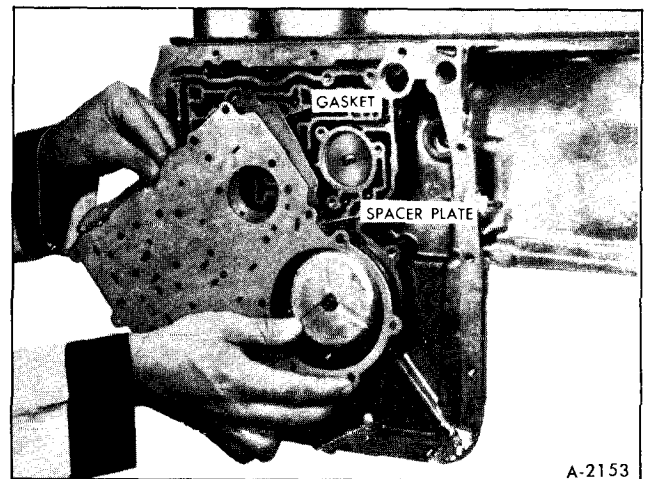

Figure 36—Removing Control Valve Spacer

NOTE: If the transmission is in the vehicle, the front servo piston assembly may drop down as the control valve assembly and governor pipe are removed.

5. Remove control valve assembly with remaining governor pipe attached.

CAUTION: Do not allow manual valve to fall out of its bore in control valve assembly.

6. Remove remaining governor pipe from valve body.
7. Remove control valve assembly to spacer gasket.
8. Remove control valve spacer and spacer-to-transmission case gasket, Figure 36.

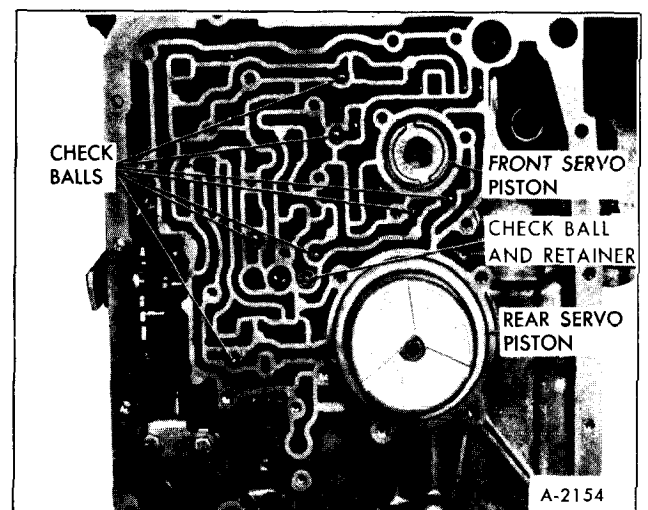

Figure 37—Location of Check Balls

CAUTION: *If control valve is removed in vehicle, seven check balls will come down with spacer.*

9. Remove seven check balls from cored passages in transmission case, Figure 37.

NOTE: The eighth check ball is held in by a retainer and should not be removed unless replacement is required.

REMOVE FRONT SERVO PISTON AND REAR SERVO PISTON

NOTE: Units may be removed with transmission in vehicle after removing bottom pan and control valve assembly.

1. Lift front servo piston retainer ring, pin, spring retainer and spring out of transmission case, Figure 37.

2. Remove rear servo assembly from transmission case, Figure 37.

3. Remove rear servo accumulator spring.

4. Make band apply pin selection check to determine proper size pin to use at time rear servo is assembled. Proceed as described in the following.

BAND APPLY PIN SELECTION CHECK (FIGURE 38)

NOTE: Check may be made with transmission in vehicle. Remove bottom pan, control valve assembly, and rear servo.

1. Position Adapter Plate, J-21370-8, on transmission case over rear servo bore, and, using screws provided with Adapter Plate, attach Band Apply Pin Selector Gage, J-21370 to Adapter Plate.

2. Position Band Apply Pin Selector Gage, J-21370, with hex nut on side of gage facing toward converter housing, and smaller diameter end of Gage Pin, J-21370-7, in servo pin bore.

3. Secure Adapter Plate to transmission case with two 5/16-18 x 1 inch screws, tightening screws to 18 foot-pounds and secure Selector Gage to Adapter Plate, tighten attaching screws to 18 foot-pounds. Make certain that stepped gage pin is free to move up and down in both tool and servo pin bore. Stepped side of pin must face rear of transmission case.

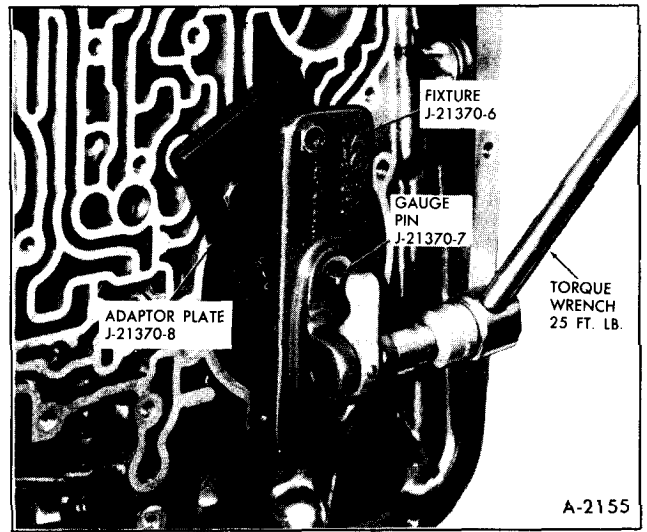

Figure 38—Checking Rear Band Apply Pin Length

Band apply pins are available in three sizes as shown in the following chart:

Identification	Length
Three Rings	Long
Two Rings	Medium
One Ring	Short

Identification ring is located on band lug end of pin. Selecting the proper pin is equivalent to adjusting band.

4. To determine proper size pin to use, apply 25 foot-pounds torque on hex nut on side of gage. This will cause lever on top of gage to depress stepped gage pin into servo pin bore, simulating actual operating conditions. Note relation of steps on gage pin and machined surface on top of gage. Determine proper size pin as follows:

a. If machined surface on top of gage is even with or above upper step on gage pin, long size pin (three rings) is required.

b. If machined surface on top of gage is even with or below lower step on gage pin, short size pin (one ring) is required.

5. If new pin is required, make note of pin size required, and remove gage from transmission case.

REMOVE DETENT LEVER, MANUAL SHAFT, AND PARKING LINKAGE (FIGURE 39)

NOTE: Units may be removed with transmission in vehicle after removing bottom pan and detent roller and spring assembly from control valve assembly.

1. Remove pin securing manual shaft to case by pulling straight out, (Be careful not to damage the case or pin).

2. Loosen locknut securing detent lever to manual shaft.

3. Pry or work detent lever loose from ground flats on manual shaft.

4. Remove manual shaft from case bore and remove and discard O-ring seal from manual shaft.

NOTE: Be careful not to drop jam nut inside of case.

5. Remove detent lever and parking brake actuator assembly from case and remove actuator assembly from detent lever.

6. Remove parking brake bracket attaching screws and remove bracket.

7. Remove retainer pin securing parking pawl shaft to transmission case by pulling straight out.

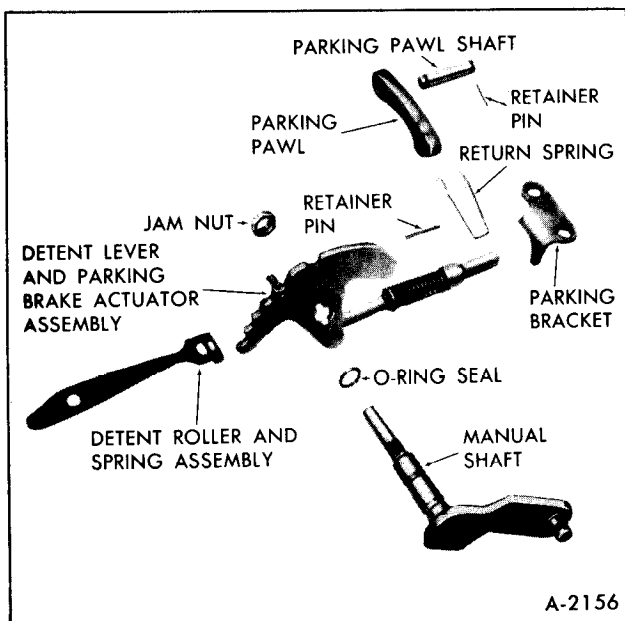

Figure 39—Manual and Parking Linkage

8. Remove parking pawl shaft, parking pawl and return spring.

REMOVE SPROCKET COVER, LINK ASSEMBLY, DRIVE AND DRIVEN SPROCKETS

1. Remove eighteen cover attaching screws.

2. Remove cover and gasket and discard gasket.

3. Install Snap Ring Pliers, J-4646, into sprocket bearing retaining snap rings located under the drive and driven sprockets, and remove snap rings from retaining grooves on support housing, Figure 40.

NOTE: Leave snap rings in a loose position between sprockets and bearing assemblies.

4. Remove drive and driven sprockets, link assembly, bearings, and shafts simultaneously by alternately pulling upwards on the drive and driven sprockets until the bearings are out of the drive and driven support housings, Figure 41.

NOTE: If the sprockets are difficult to remove, place a small piece of fiberboard between the sprocket and sprocket support cover. Using a 1/2 x 9 inch pry bar, alternately pry upward under each sprocket on sprocket support cover. Do not pry on the guide links or the aluminum case. Pry only on the sprockets, Figure 42.

5. Remove link assembly from drive and driven sprockets.

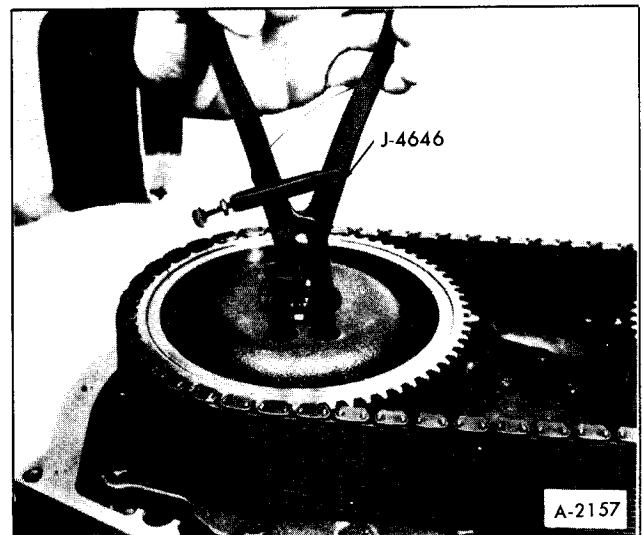

Figure 40—Removing Sprocket to Housing Snap Rings

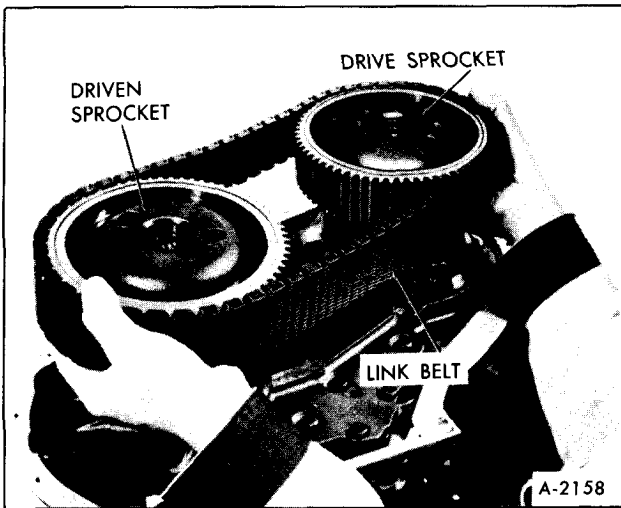

Figure 41—Removing Sprocket & Link Assembly

6. Remove the hook type oil seal ring from turbine shaft.

7. Inspect drive and driven sprocket bearing assemblies for rough or defective bearings.

NOTE: Do not remove bearing assemblies from drive and driven sprockets unless they need replacement.

8. If removal of bearing assembly from drive and/or driven sprockets is necessary, proceed as follows:

a. Remove sprocket to bearing assembly retaining snap ring using Snap Ring Pliers, J-8059, Figure 43.

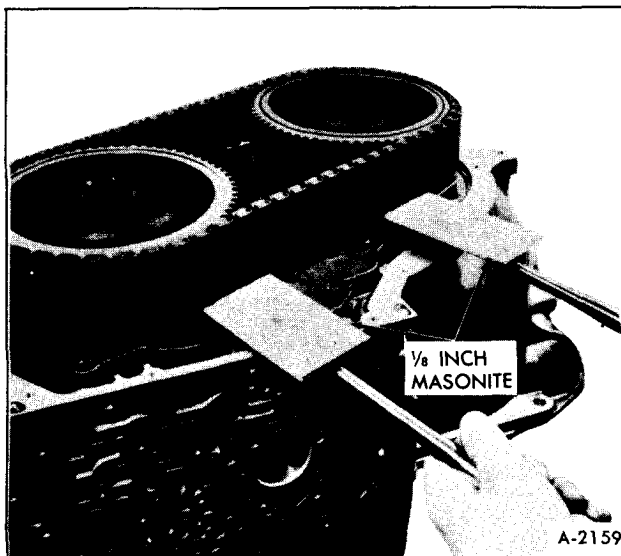

Figure 42—Removing Tight Sprockets

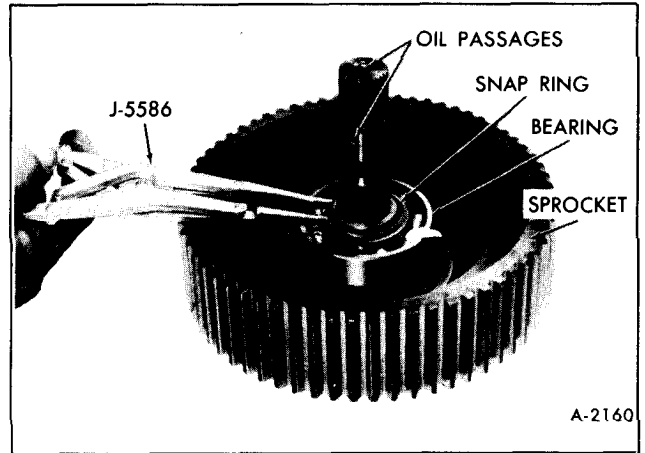

Figure 43—Removing Sprocket Bearing Snap Ring

b. Mount sprocket, with turbine or input shaft placed down between two 2" x 4" x 10" wood blocks.

NOTE: Wood blocks are positioned on sides or ends, depending on which bearing is to be replaced.

c. With a hammer and brass rod, drive the inner race, alternately through each of the access openings, until the bearing assembly is removed from the sprocket hub, Figure 44.

INSPECT DRIVE SPROCKET, TURBINE SHAFT, AND LINK ASSEMBLY

1. Inspect drive sprocket teeth for nicks, burrs, scoring, galling, and excessive wear.

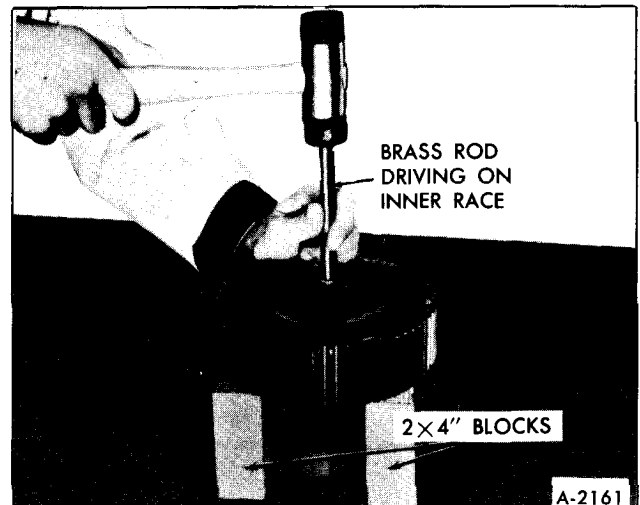

Figure 44—Removing Sprocket Bearing

NOTE: Wear pattern at bottom of tooth form is normal.

2. Inspect drive sprocket to ball bearing retaining snap ring for damage.
3. Inspect drive sprocket ball bearing inner race mounting surface for damage.
4. Inspect turbine shaft for open lubrication passages. Run a tag wire through the passages to be sure they are open. See lubrication chart for passage location, Figure 19.
5. Inspect spline for damage.
6. Inspect the ground bushing journals for damage.
7. Inspect the hook type oil seal groove for damage or excessive wear.
8. Inspect the turbine shaft for cracks or distortion.
9. Inspect the link assembly for damage or loose links.

NOTE: Check the guide links. Guide links are the wide outside links on each side of the link assembly.

INSPECT DRIVEN SPROCKET AND INPUT SHAFT

1. Inspect driven sprocket teeth for nicks, burrs, scoring, galling, and excessive wear.

NOTE: Wear pattern at bottom of tooth form is normal.

2. Inspect sprocket to ball bearing retaining snap ring for damage.
3. Inspect ball bearing inner race mounting surface for damage.
4. Inspect input shaft for open lubrication holes. Run a tag wire through the holes to be sure they are open. See Figure 19 for location of holes.
5. Inspect spline for damage.
6. Inspect ground bushing journal for damage.

INSTALL SPROCKET BEARINGS

1. Turn sprocket so that turbine or input shaft is pointing upward.

2. Install new sprocket bearing as follows:

- a. Install support snap ring, letter side down onto shaft.
- b. Assemble bearing assembly on turbine or input shaft.
- c. Using a piece of pipe, drive the bearing assembly onto the hub of the sprocket until it is resting on the bearing seat of the sprocket.

CAUTION: Use pipe that closely fits I.D. of bearing assembly but does not contact shaft.

- d. Install sprocket to bearing assembly retaining snap ring into groove in sprocket hub.

3. Install new hook type oil seal ring on turbine shaft, (Note: original ring is plastic).

NOTE: Turbine and/or input shaft may appear not to be pressed fully into the sprocket. Do not attempt pressing shaft further as a specific length dimension is held during initial assembly.

FRONT UNIT END PLAY CHECK

1. Install Front Unit End Play Checking Tool, J-22241, into driven sprocket housing so that the urethane on the tool can engage the splines in the forward clutch housing. Let the tool bottom on the mainshaft and then withdraw it approximately 1/8 inch and tighten nut on tool, Figure 45.

2. Remove two of the 5/16" bolts from the driven support housing.

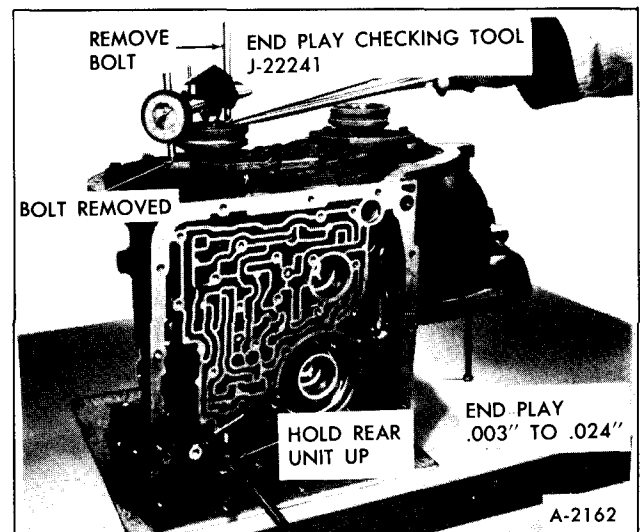

Figure 45—Checking Front Unit End Play

Install 5/16" threaded slide hammer bolt with jam nut into one bolt hole in driven support housing.

NOTE: Do not thread slide hammer bolt deep enough to interfere with forward clutch housing travel.

3. Mount Dial Indicator, such as J-8001, on slide hammer bolt and index indicator to register with the Front Unit End Play Checking Tool, J-22241, Figure 45 and push tool down to remove slack.

4. Push and hold output flange upward. Place a screw driver in case opening at parking pawl area and push upward on output carrier.

5. Place another screw driver between the metal lip of the end play tool and the driven sprocket housing and push upward on the metal lip of the end play tool and read the resulting end play, which should be between .003" and .024".

The selective washer controlling this end play is the thrust washer located between the driven support housing and the forward clutch housing. If more or less washer thickness is required to bring the end play within specifications, select the proper washer from the chart below:

THICK- NESS	COLOR
.060-.064	Yellow
.071-.075	Blue
.082-.086	Red
.093-.097	Brown
.104-.108	Green
.115-.119	Black
.126-.130	Purple

NOTE: An oil soaked washer may tend to discolor so that it will be necessary to measure the washer with a set of one inch micrometers to determine its actual thickness.

6. Remove end play tool from transmission and remove dial indicator and slide hammer bolt from transmission.

REMOVE OIL PUMP

1. Remove two opposite pump attaching bolts from the drive support housing.

2. Install two 5/16-18 x 4" guide pins in holes from previously removed bolts.

3. Remove the remaining pump attaching bolts from the drive support housing.

4. With one hand hold the underside of the pump and gently tap the guide pins until the pump is removed from the case.

REMOVE PUMP COVER PLATE, CONVERTER OUT CHECK VALVE AND DRIVE AND DRIVEN SUPPORT HOUSING ASSEMBLIES

1. Remove the twenty-three pump cover plate-to-case attaching screws and remove pump cover plate. Do not remove sprocket support housing bolts at this time.

2. Remove pump cover plate and plate-to-case face gasket. Discard gasket.

NOTE: Drive and driven support housing assemblies are pressed into and removed with the pump cover plate. Do not remove them unless it is necessary.

3. Remove oil seal rings from the driven support housing.

4. Remove the front unit end play selective thrust washer from the hub of the driven support housing.

5. If necessary to remove the drive and driven sprocket support housing assemblies, proceed as follows:

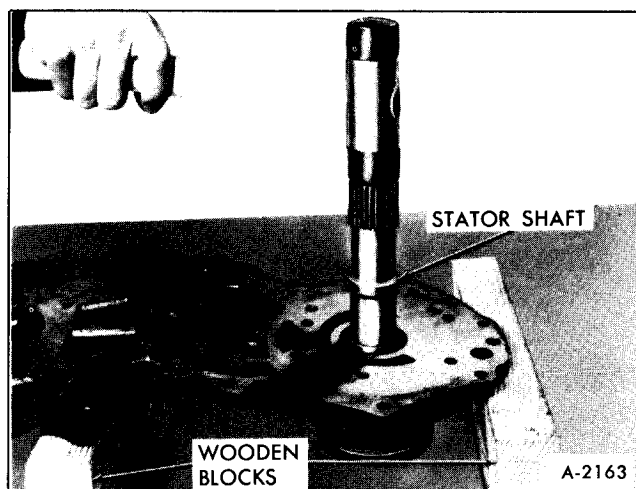

Figure 46—Removing Drive Sprocket Support

a. Remove the remaining sprocket support to pump cover plate attaching bolts.

b. Support cover plate on wooden blocks and using a plastic mallet, vigorously strike the stator shaft of the drive sprocket support, Figure 46, and the hub of the driven sprocket support, until they are removed from their pump cover plate bores.

CAUTION: *When driving the housings out of the pump cover plate, avoid damaging or distorting the stator shaft or the ring grooves in the hub of the driven housing by striking the shaft or hub centrally.*

c. Remove and discard housing to pump cover plate gaskets.

d. Remove converter out check valve, Figure 47.

e. Install converter out check valve.

f. Install drive sprocket support housing to pump cover plate gasket.

g. Install drive sprocket support housing into pump cover plate by using a plastic mallet to seat the housing. Use bolts for guides, Figure 48.

h. Install driven sprocket support housing to pump cover plate gasket.

i. Install driven sprocket support housing to pump cover plate attaching bolts for gasket guides.

j. Install driven sprocket support housing into

pump cover plate by using a plastic mallet to seat the housing.

k. Install all but one driven support housing to pump cover plate attaching bolts. Torque to 20 ft. lbs.

6. Install proper front unit end play selective thrust washer on the hub of the driven sprocket support housing. Use micrometer to determine the actual thickness of the thrust washer.

7. Install one hook type and one teflon oil seal ring into the grooves in the hub of the driven sprocket support housing.

REMOVE FORWARD CLUTCH ASSEMBLY, DIRECT CLUTCH ASSEMBLY, SUN GEAR SHAFT, AND FRONT BAND

1. Remove forward clutch assembly from transmission, Figure 49, by installing Front End Play Checking Tool, J-22241, into forward clutch and lifting forward clutch straight out.

2. Remove forward clutch hub to direct clutch housing thrust washer if it did not come out with forward clutch assembly.

3. Remove direct clutch and intermediate sprag assembly by lifting straight out. Sun gear shaft may come out with direct clutch assembly.

4. Remove sun gear shaft if not previously removed.

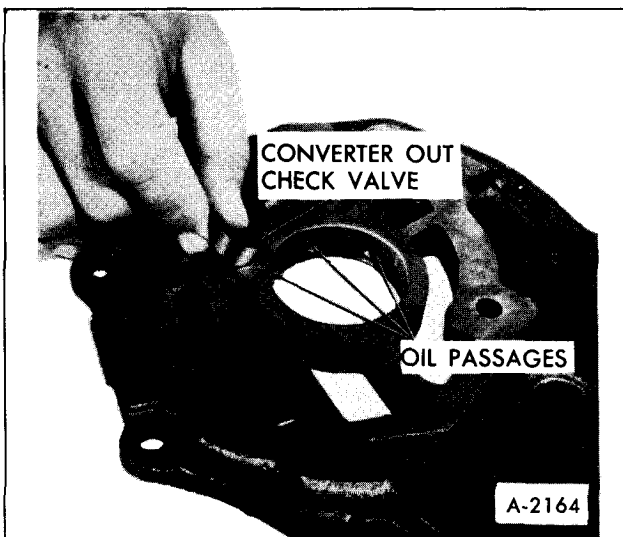

Figure 47—Converter Out Check Valve

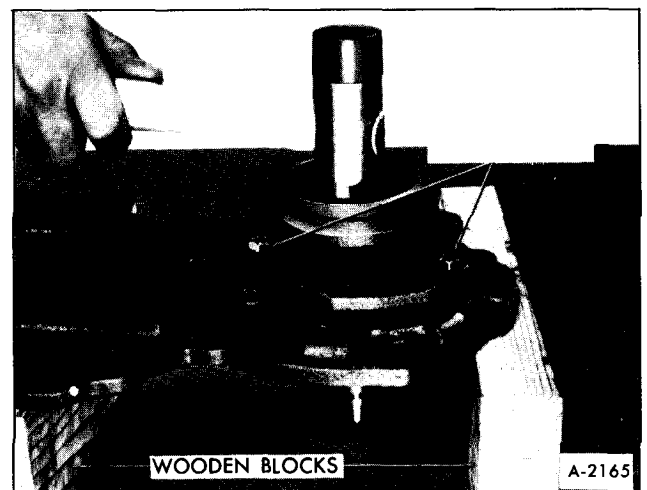

Figure 48—Installing Drive Sprocket Support

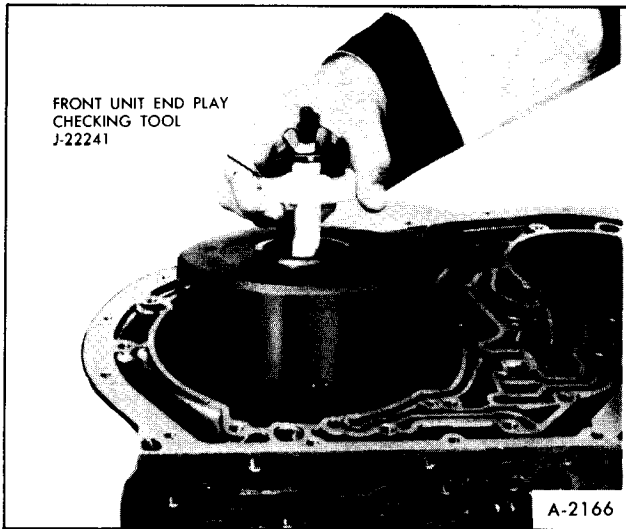

Figure 49—Removing Forward Clutch

5. Remove front band assembly.

NOTE: Check rear unit end play at this time.

REAR UNIT END PLAY CHECKING PROCEDURE

Make rear unit end play check as follows:

a. Install 3/8" bolt for slide hammer into one

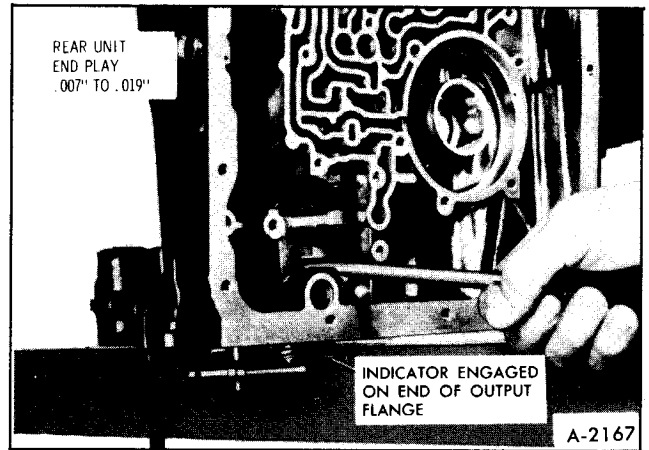

Figure 50—Rear Unit End Play

of the final drive attaching bolt holes. Allow end of case to hang over edge of bench, Figure 50.

b. Mount dial indicator on the bolt and index with end of output flange.

c. Move the output flange in and out to read the end play. End play should read .007" to .019". The selective washer controlling this end play is the steel washer having three lugs that is located between the output flange thrust washer and the rear face of the transmission case.

If a different washer thickness is required to bring the end play within specifications, it can be selected from the following chart:

Thickness	Notches and/or Numeral
.074" to .078"	None 1
.082" to .086"	1 Tab Side..... 2
.090" to .094"	2 Tab Side..... 3
.098" to .102"	1 Tab O.D. 4
.106" to .110"	2 Tabs O.D. 5
.114" to .118"	3 Tabs O.D. 6

REMOVE REMAINING COMPONENTS

1. Remove center support bolt from transmission case, Figure 51, using a 3/8 inch 12-point thin wall deep socket.

2. Remove intermediate clutch backing plate to case snap ring, Figure 52.

3. Remove intermediate clutch backing plate, and three composition and three steel clutch plates.

4. Using a needle-nose pliers, or screwdriver, remove center support to case snap ring, Figure 53.

5. Install Gear Assembly Remove and Installer Adapter, J-21795, on end of main shaft so that tangs engage groove in shaft. Using Slide Hammer Handle, such as J-6125, and Speedometer Puller Bolt, J-

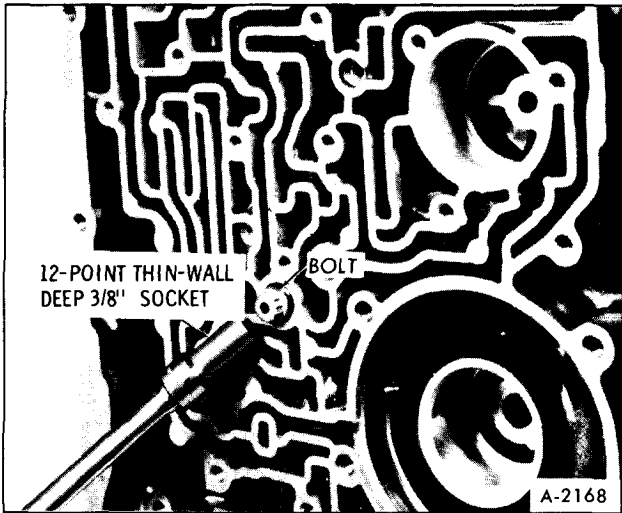

Figure 51-Remove Center Support Bolt

21797, tighten bolt on tool to secure tool on shaft, Figure 54.

6. Remove complete gear unit assembly from case, by lifting straight up.

CAUTION: *Be careful not to drop or bump assembly in transmission case during removal.*

7. Remove output flange to case metal thrust washer from output flange or case.

8. Place gear unit assembly on bench with output flange down, Figure 55. Remove Tool J-21795.

9. Remove support to case spacer.

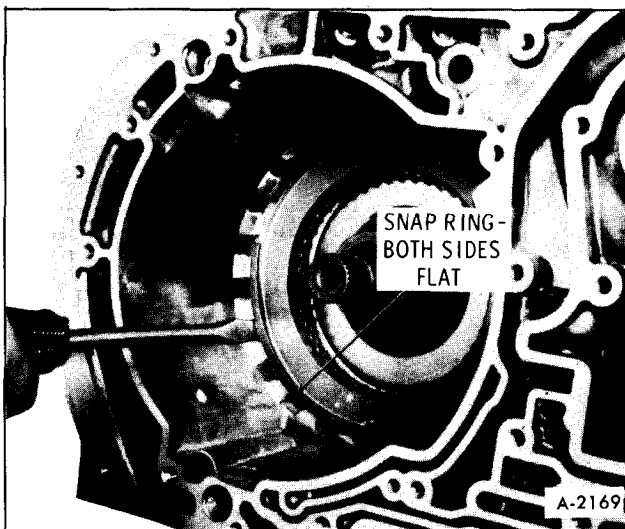

Figure 52-Intermediate Clutch Snap Ring

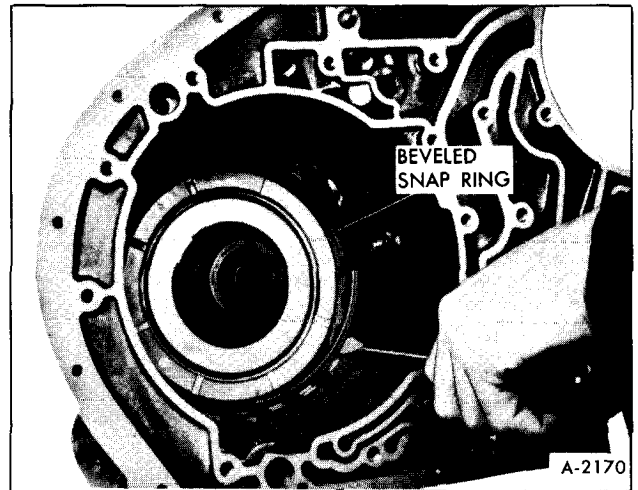

Figure 53-Center Support Snap Ring

10. Remove rear band assembly. To facilitate removal, rotate band lugs away from pins and pull band assembly out of transmission case.

11. Remove rear unit selective washer from transmission case.

INSPECTION OF TRANSMISSION CASE

1. Inspect case assembly for cracks, porosity or interconnected passages, Figure 20.

2. Check for good retention of band anchor pins.

3. Inspect all threaded holes for thread damage. (use insert to rebores threads if necessary).

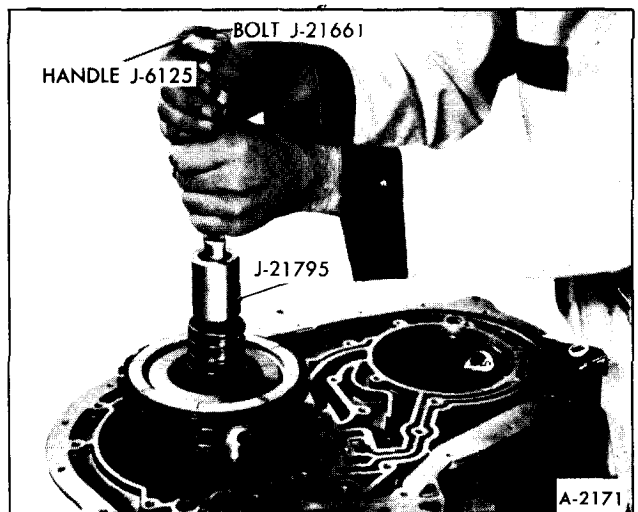

Figure 54-Gear Unit Removal

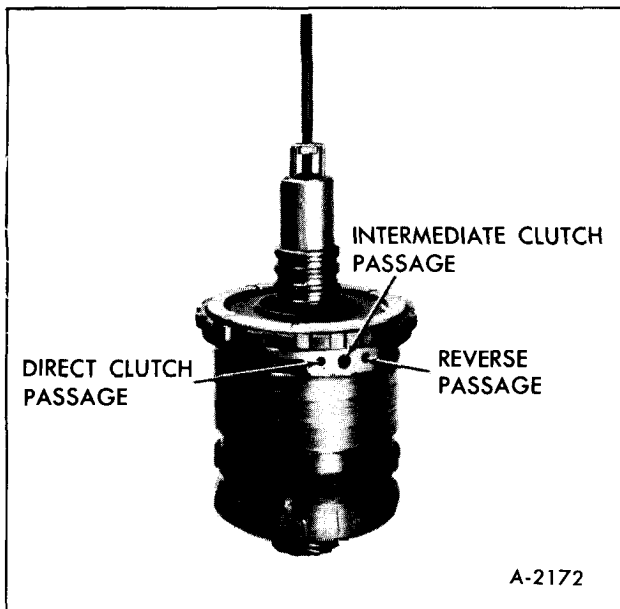

Figure 55-Gear Unit on Bench

4. Inspect intermediate clutch driven plate lugs for damage or brinelling.
5. Inspect snap ring grooves for damage.
6. Inspect governor assembly bore for scratches or scoring.
7. Inspect governor pipes screen assemblies (located in governor pipe holes in case) for plugging or damage.
8. Inspect modulator valve bore for scoring or damage.
9. Inspect output flange bushing for wear, galling and open lubrication groove.

CENTER SUPPORT AND GEAR UNIT

DISASSEMBLY

1. Remove center support assembly from reaction carrier by lifting center support straight up.
2. Remove center support to reaction carrier thrust washer.

NOTE: Thrust washer may have stuck to back of center support. If so, remove from center support.

3. Remove reaction carrier and roller clutch as-

sembly from output carrier, Figure 56, and remove roller clutch assembly from reaction carrier.

4. Remove center support to sun gear races and thrust bearing from sun gear.

NOTE: One of the races may have stuck to back of center support.

5. Remove front internal gear ring from output carrier assembly, Figure 57.

6. Remove sun gear from output carrier assembly.

7. Remove reaction carrier to output carrier plastic thrust washer from output carrier.

8. Invert gear unit and place in Rear Unit Holding Fixture, J-6116, with main shaft pointing downward.

9. Remove snap ring securing output flange to output carrier and remove output flange.

10. Remove thrust bearing and races from rear internal gear.

11. Lift rear internal gear and main shaft out of output carrier and remove thrust bearing and races from inner face of rear internal gear.

12. Remove snap ring from end of main shaft and remove rear internal gear.

13. Remove output carrier from holding fixture.

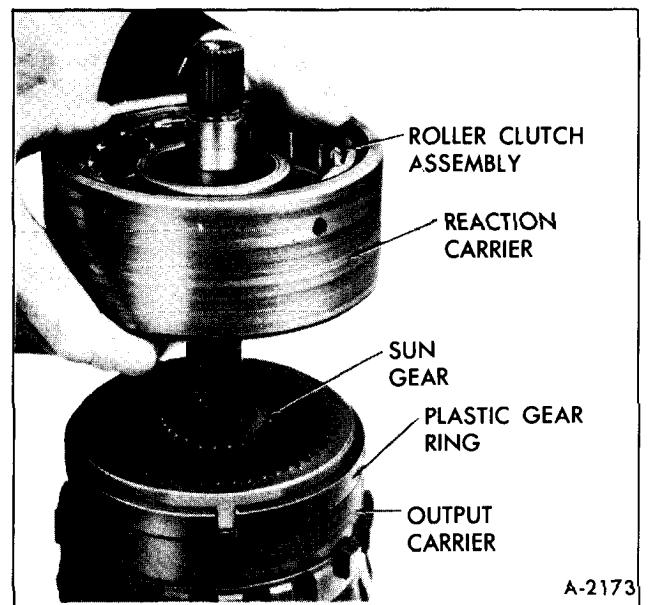

Figure 56-Removing Reaction Carrier

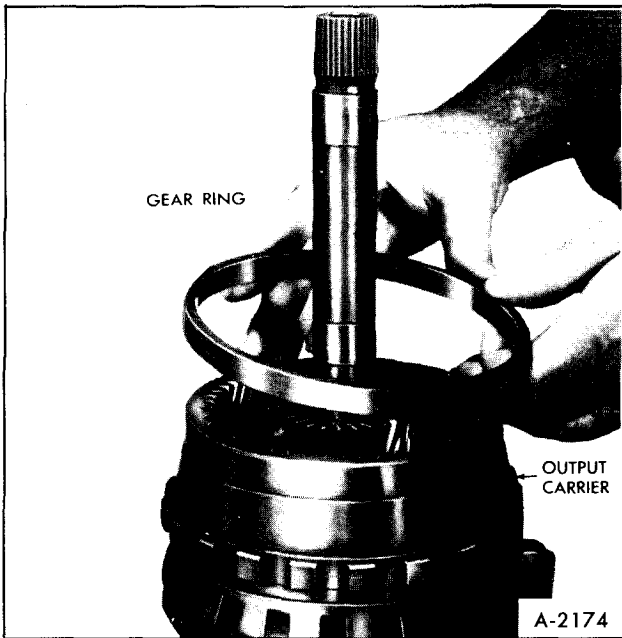

Figure 57—Removing Gear Ring

INSPECT OUTPUT FLANGE

1. Inspect bearing and thrust washer surfaces for damage.
2. Inspect drive lugs for damage.
3. Inspect splines for damage.
4. Inspect lubrication passages.

INSPECT MAIN SHAFT

1. Inspect shaft for cracks or distortion.
2. Inspect splines for damage.
3. Inspect ground bushing journals for damage.
4. Inspect snap ring groove for damage.
5. Inspect lubrication passages.

INSPECT REAR INTERNAL GEAR

1. Inspect gear teeth for damage or wear.
2. Inspect splines for damage.
3. Inspect gear for cracks.

4. Inspect bearing and thrust surfaces for wear or galling.

INSPECT OUTPUT CARRIER

1. Inspect front internal gear for damaged teeth.
2. Inspect pinion gears for damage, rough bearings or excessive tilt.
3. Check pinion end play. Pinion end play should be .009 inch-.024 inch, Figure 58.
4. Inspect parking gear lugs for cracks or damage.
5. Inspect output flange locating splines for damage.
6. Inspect front internal gear ring for flaking or cracks.

INSPECT REACTION CARRIER

1. Inspect band surface on reaction carrier for signs of burning or scoring.
2. Inspect roller clutch outer cam for scoring or wear.
3. Inspect thrust washer surfaces for signs of scoring or wear.
4. Inspect bushing for damage. If bushing is damaged, carrier must be replaced.
5. Inspect pinion gears for damage, rough bearings or excessive tilt.
6. Check pinion end play. Pinion end play should be .009 inch-.024 inch.

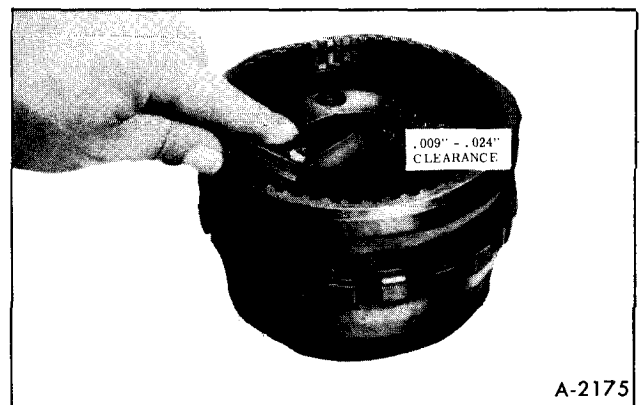

Figure 58—Check-Pinion End Play

PINION GEAR REPLACEMENT-REACTION AND OUTPUT CARRIER ASSEMBLIES

1. Support carrier assembly on its FRONT face.

2. Using a 1/2 inch diameter drill, remove the stake marks from the end of the pinion pin, or pins, to be replaced. This will reduce the probability of cracking the carrier when the pinion pins are pressed out.

CAUTION: *Do not allow drill to remove any stock from the carrier, as this will weaken the part, and could cause the carrier to break.*

3. Using a tapered punch, drive or press pinion pins out of carrier.

4. Remove pinion gears, thrust washers, and roller needle bearings.

5. Inspect pinion pocket thrust faces for burrs and remove if present.

6. Install eighteen needle bearings into each pinion gear using petrolatum to hold bearings in place. Use a pinion pin as a guide.

7. Place a bronze and steel thrust washer on each side of pinion gear with steel washers against gear, Figure 59. Hold washers in place with petrolatum.

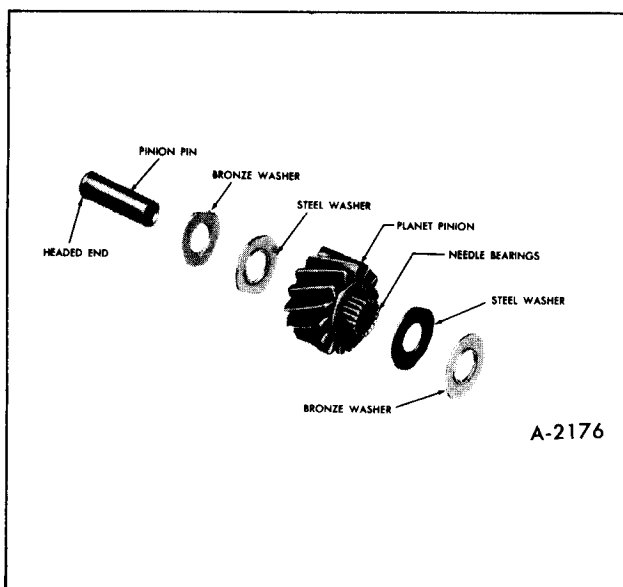

Figure 59—Planet Pinion Components

8. Place pinion gear assembly in position in carrier and install a pilot shaft through rear face of assembly to hold parts in place.

9. Drive a new pinion pin into place from the front, while rotating pinion gear. Be sure that headed end is flush or below face of carrier.

10. Using a punch in bench vise for an anvil, stake opposite end of pinion pin in three places with a blunt radius chisel, Figure 60.

NOTE: Both ends of pinion pins must lie below face of carrier or interference may occur.

11. Repeat installation procedure for each pinion gear.

INSPECT ROLLER CLUTCH

1. Inspect roller clutch for damaged rollers or springs.

2. Inspect roller clutch cage for damage.

INSPECT SUN GEAR

1. Inspect gear teeth for damage or wear.

2. Inspect splines for damage.

3. Be sure oil lubrication hole is open.



Figure 60—Staking Pinion Pin

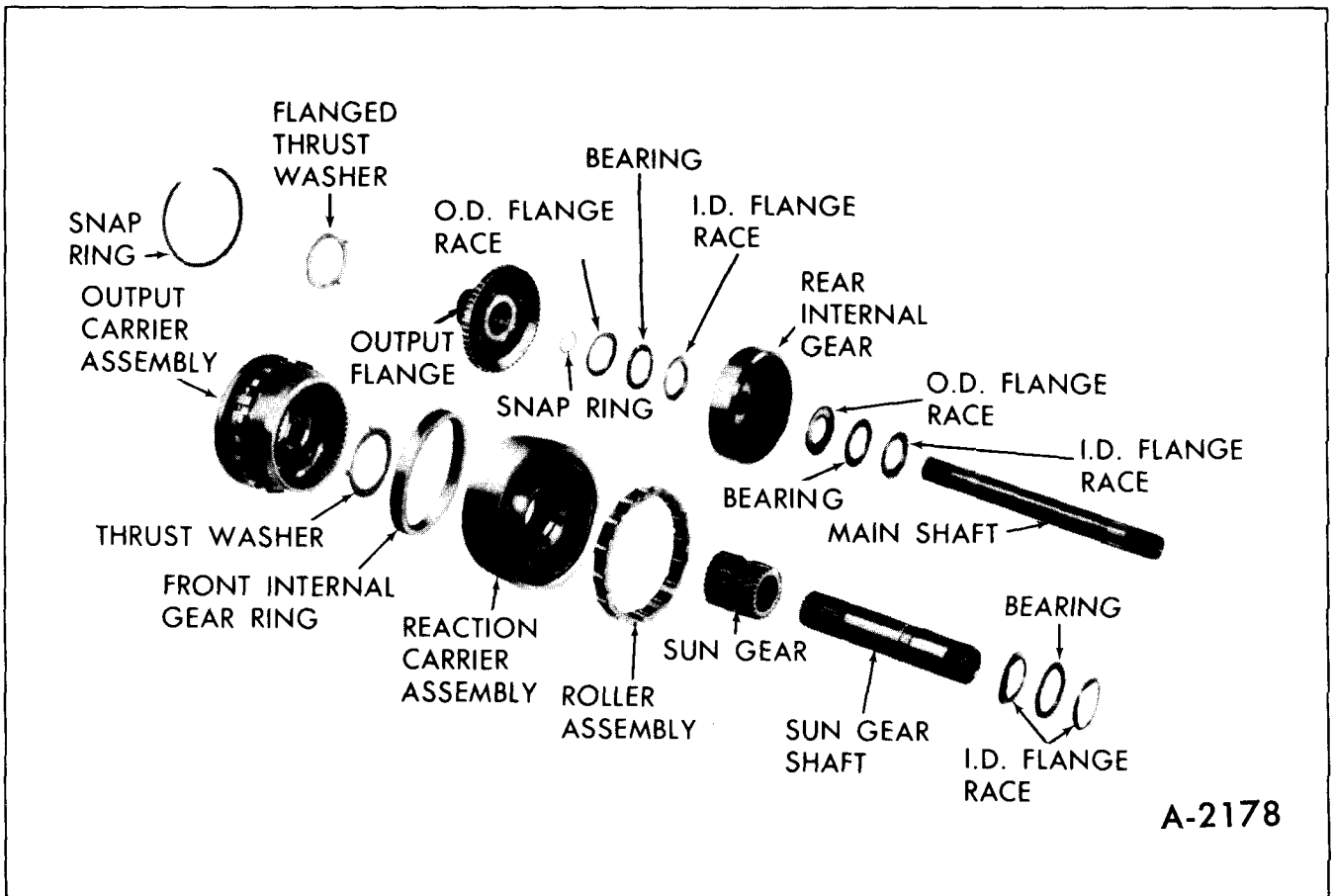

A-2178

Figure 61-Gear Unit Components

INSPECT SUN GEAR SHAFT

1. Inspect shaft for cracks or splits.
2. Inspect splines for damage.
3. Inspect bushings for scoring or galling.
4. Inspect ground bushing journals for damage.
5. Be sure oil lubrication hole is open.

ASSEMBLE GEAR UNIT (FIGURE 61)

1. Install rear internal gear on end of main shaft that has snap ring groove and install snap ring.
2. Install races and thrust bearing on inner face of rear internal gear, retaining races and bearing with petrolatum. Proceed as follows:

a. Install large diameter race first, with flange facing up, Figure 62.

b. Install thrust bearing in race.

c. Install small diameter race on bearing with inner flange facing down.

3. Lubricate pinion gears in output carrier with transmission fluid and install output carrier on main shaft so that pinion gears mesh with rear internal gear.

4. Place the above portion of the build-up through hole in bench so that the mainshaft hangs downward.

5. Install the rear internal gear to output flange thrust races and bearings as follows: (Retain with petrolatum) (figure 63).

a. Place the small diameter race against the internal gear with the center flange facing up.

b. Place the bearing on the race.

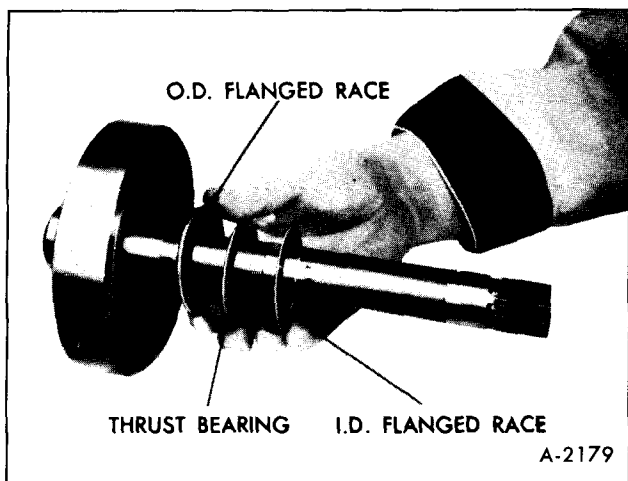

Figure 62—Thrust Bearing Installation

c. Place the second race on the bearing with the outer flange cupped over the bearing.

6. Install the output flange into the output carrier assembly.

7. Install the output flange to the output carrier snap ring.

8. Invert assembly and place on bench with output flange downward.

9. Lubricate tab side of reaction carrier to output carrier thrust washer with petrolatum and install thrust washer in output carrier with tabs in tab pockets.

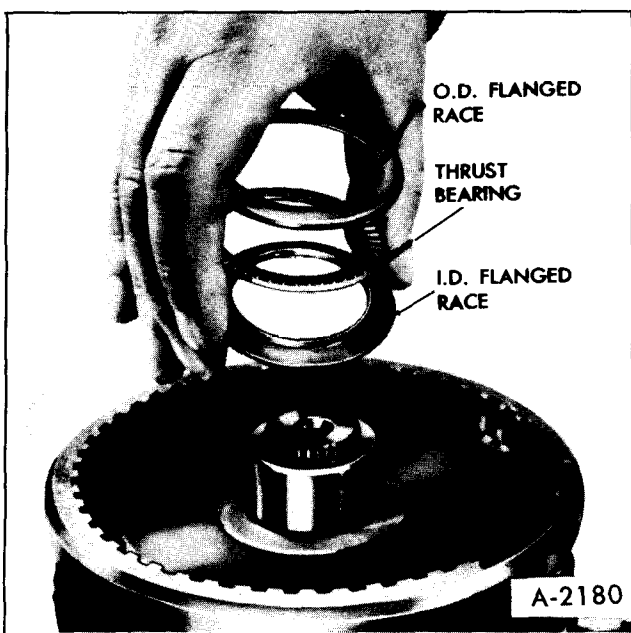

Figure 63—Installing Output Flange Thrust Bearing

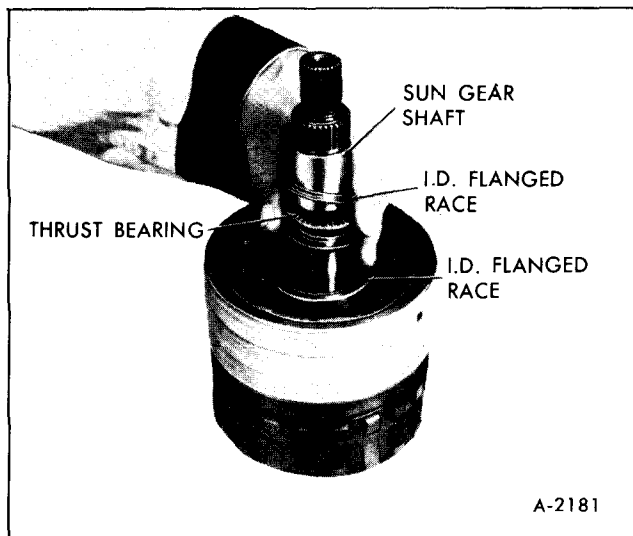

Figure 64—Installing Thrust Bearing over Sun Gear Shaft

10. Install sun gear with end having chamfered I.D. facing down.

11. Install sun gear shaft with longer splined end down.

12. Install gear ring over output carrier.

13. Lubricate pinion gears in reaction carrier with transmission fluid and install reaction carrier on output carrier so that pinion gears mesh with front internal gear.

NOTE: When a new output carrier and/or reaction carrier is being installed, and if the front internal gear ring prevents assembly of the carriers, replace the front internal gear ring with the service ring. The front internal gear ring is a selective fit at the factory, but not in service.

14. Install large diameter O.D. race on sun gear with flange facing up against sun gear shaft.

15. Install thrust bearing on race.

16. Lubricate small diameter race with petrolatum and install race on center support with flange facing toward tower end, Figure 64.

17. Install rollers that may have come out of roller clutch cage, by compressing energizing spring with forefinger and inserting roller from outer side.

NOTE: Make certain that energizing springs are not distorted, and that curved end leaf of springs are positioned against rollers.

18. Install roller clutch assembly in reaction carrier, Figure 65.

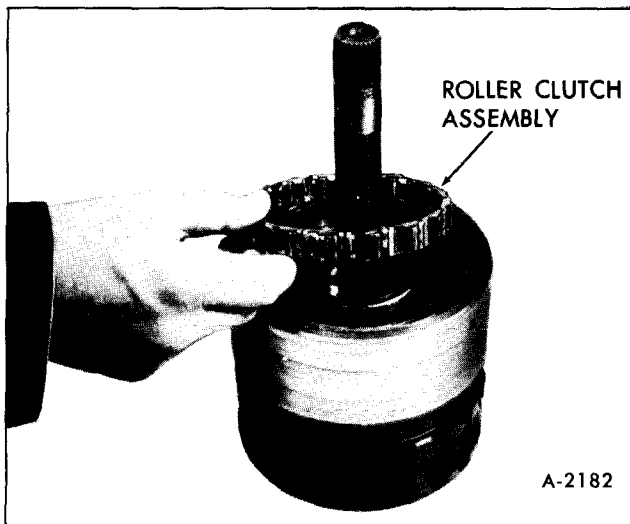

Figure 65—Roller Clutch Installation

DISASSEMBLE CENTER SUPPORT AND INTERMEDIATE CLUTCH PISTON

1. Remove center support to reaction carrier thrust washer from recess in center support.
2. Remove oil seal rings from the center support. All service center support oil seal rings are hook type cast iron.
3. Using Clutch Spring Compressor, J-4670, and Rear Clutch Spring Compressor, J-6129, Figure 66, compress spring retainer and remove snap ring with Snap Ring Pliers, J-8059 or J-5586.
4. Remove spring retainer, six intermediate clutch release springs, and spring guide.
5. Remove intermediate clutch piston from center support.
6. Remove inner and outer seals from clutch piston.

NOTE: Do not remove the three screws retaining roller clutch inner race to center support.

INSPECT CENTER SUPPORT

1. Inspect roller clutch inner race for scratches or indentations. Be sure lubrication hole is open.
2. Inspect bushing for scoring, wear or galling.

3. Check oil ring grooves for damage.
4. Air check oil passages to be sure they are open and not interconnected.
5. Inspect piston sealing surfaces for scratches.
6. Inspect piston seal grooves for nicks or other damage.
7. Inspect piston for cracks.
8. Inspect springs for collapsed coils or signs of distortion.
9. Inspect oil seal rings for damage.

NOTE: All service center support oil seal rings are hook type cast iron.

ASSEMBLE CENTER SUPPORT AND INTERMEDIATE CLUTCH PISTON ASSEMBLY

1. Lubricate new inner and outer clutch piston seals with transmission fluid. Lubricate seal grooves in intermediate clutch piston and install seals with lips facing away from spring guide.
2. Place Intermediate Clutch Inner Seal Protector, J-21363, over center support hub and install intermediate clutch piston.
3. Install plastic spring guide.
4. Install six clutch release springs equally spaced into spring holes in spring guide.

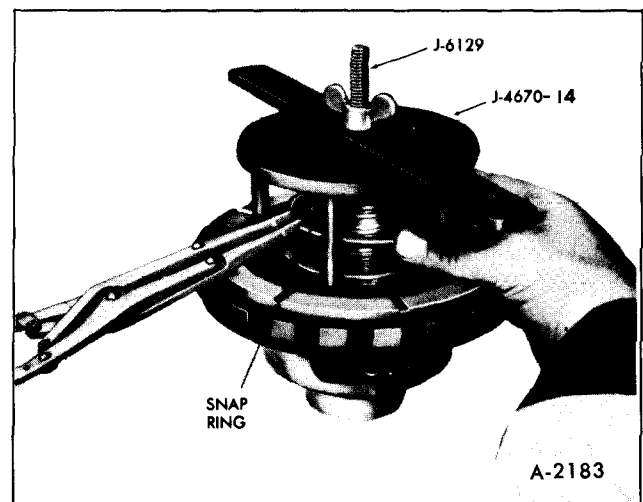

Figure 66—Removing Intermediate Clutch Retaining Snap Ring

5. Place spring retainer and snap ring over springs.

6. Using Clutch Spring Compressor, J-4670, and Rear Clutch Spring Compressor, J-6129, Figure 66, compress spring retainer, being careful that retainer does not get caught in snap ring groove, and install snap ring with Snap Ring Pliers. J-8059 or J-5586. Remove tools.

7. Install four oil seal rings on the center support.

8. Lubricate center support to reaction carrier thrust washer with petrolatum and install washer in recess of center support, Figure 67. Check to make sure sun gear thrust bearing race is on center support.

9. Install center support assembly into roller clutch in reaction carrier, Figure 68.

NOTE: With reaction carrier held, center support should turn clockwise only.

10. Install Gear Assembly Remover and Installer Adapter, J-21795, on end of main shaft so that tangs engage groove in shaft. Using Slide Hammer Handle, J-6125, and Speedometer Puller Bolt, J-21797, tighten bolt on tool to secure tool on shaft and prevent movement of the roller clutch during installation of the gear unit assembly, Figure 54.

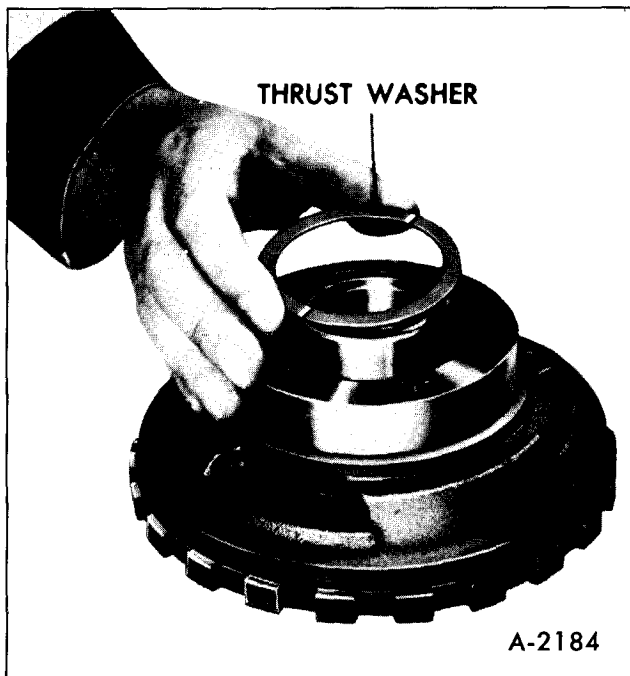

Figure 67—Center Support to Reaction Carrier Thrust Washer

INSTALL REAR BAND AND COMPLETE GEAR UNIT ASSEMBLY

1. Inspect rear band for cracks or distortion and band ends for damage to anchor lugs and apply lug. Also inspect lining for cracks, flaking, burning and looseness.

2. Install rear band assembly in transmission case so that band lugs index with anchor pins.

3. Inspect support to case spacer for burrs or raised edges. If present, remove with a stone or fine sandpaper.

4. Install the support case spacer against the shoulder at the bottom of case splines and the gap located adjacent to the band anchor pin, Figure 69.

CAUTION: Do not confuse this spacer (.040" thick and both sides flat) with either the center support to case snap ring (one side beveled) or the intermediate clutch backing plate to case snap ring (.093" thick and both sides flat).

5. Install previously selected rear unit selective washer into slots provided inside rear of transmission case. Retain washer with petrolatum.

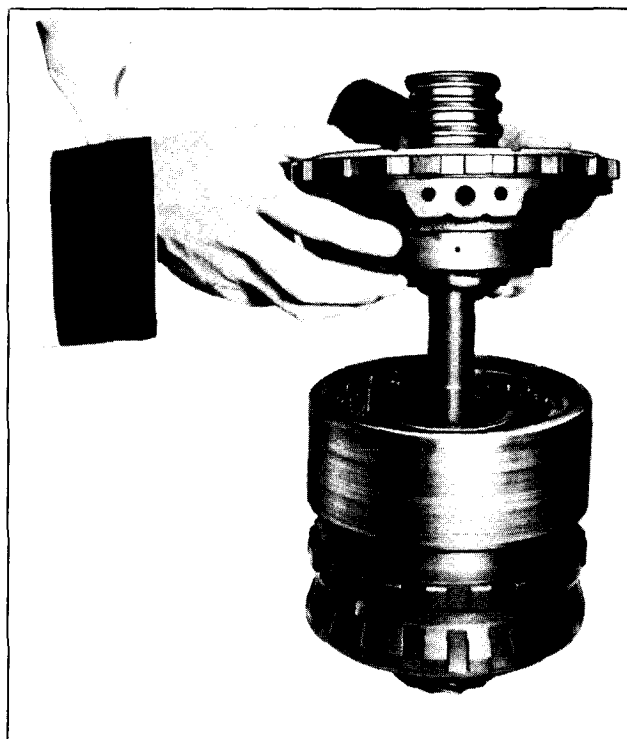

Figure 68—Center Support Installation



Figure 69—Installing Support-to-Case Spacer

NOTE: Proper washer size was determined at time of rear unit end play check.

6. Laying gear unit on its side, install metal thrust washer on output flange with bent tabs in tab pockets. Retain thrust washer with petrolatum.

CAUTION: *Be careful not to drop or bump gear unit assembly in transmission case during installation.*

7. Install gear unit, with center support and reaction carrier, by lining up center support bolt hole with hole in case and carefully guiding complete assembly into transmission case.

8. Lubricate center support to case snap ring with transmission fluid and install snap ring in transmission case with beveled side up, (flat side against center support) locating gap adjacent to front band anchor pin. Expand snap ring until center support is against shoulder of case.

9. Install case to center support bolt.

NOTE: To correctly perform this operation, it will be necessary to make the tool shown in Figure 70. Then follow procedure outlined below:

Place center support locating tool into the case direct clutch passage, with the handle of the tool pointing to the left, as viewed from the front of transmission and parallel to the bell housing mounting, Figure 71.

Lift upward on the tool which will tend to rotate the center support counterclockwise as viewed from the front of transmission. While holding the center

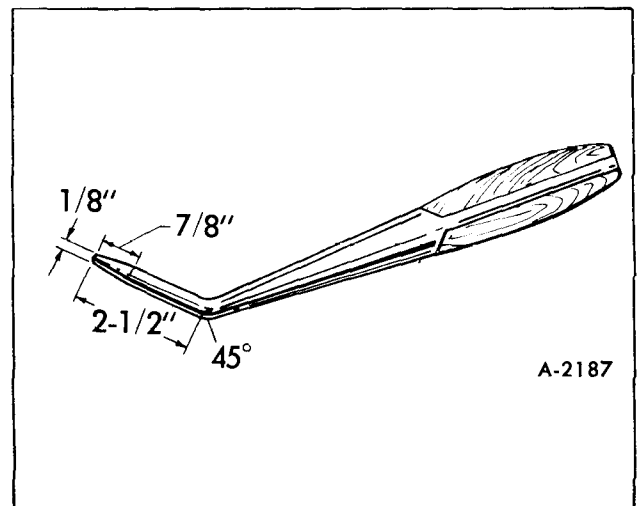

Figure 70—Center Support Locating Tool

support firmly counterclockwise against case splines, torque case to center support bolt to 23 ft. lbs., using a 3/8" 12-point thin-wall deep socket.

CAUTION: *When using the locating tool, care should be taken not to raise burrs on the case valve mounting face.*

10. Before installing intermediate clutch plates, inspect plates for signs of burning, scoring, and wear.

11. Lubricate three steel and three composition intermediate clutch plates with transmission fluid and install clutch plates in transmission case, Figure 72. Start with steel plate and alternate composition and steel plates.

12. Install intermediate clutch backing plate with flat machine surface against clutch plates.

13. Install backing plate to case snap ring with

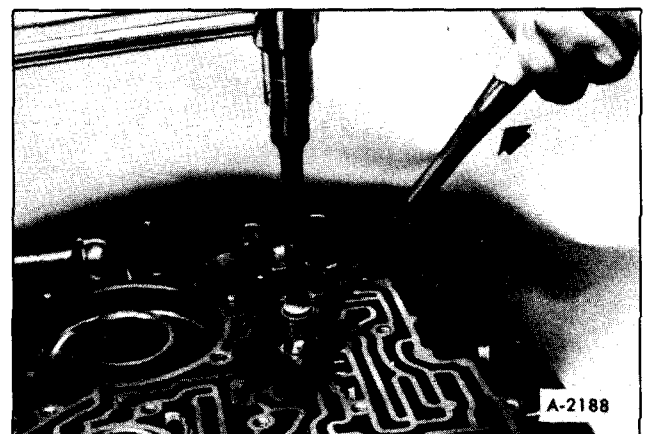

Figure 71—Locating Center Support

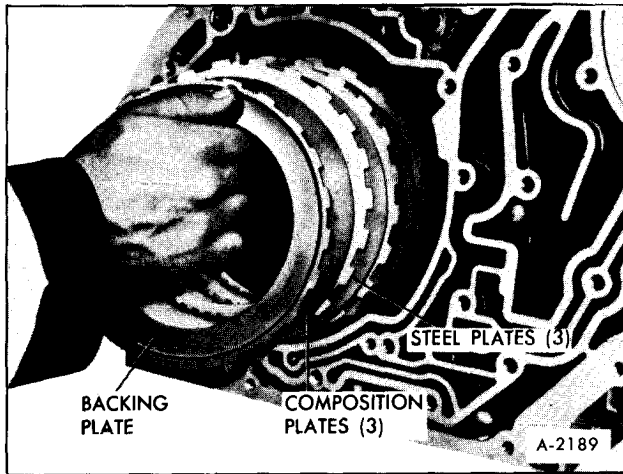

Figure 72—Installing Intermediate Clutch

snap ring gap on side of case opposite front band anchor pin.

NOTE: Both sides of this snap ring are flat, and it is approximately .093" thick.

14. Air check operation of intermediate clutch piston. Apply air through center oil feed hole to actuate clutch piston.

15. Recheck rear unit end play as described previously.

DIRECT CLUTCH AND INTERMEDIATE SPRAG ASSEMBLY (FIGURE 73)

DISASSEMBLY

1. Remove sprag retainer snap ring, and remove clutch retainer.

2. Remove sprag outer race and bushings, and remove sprag assembly from outer race.

3. Turn unit over and remove direct clutch backing plate to clutch housing snap ring.

4. Remove direct clutch backing plate and six composition and six steel clutch plates.

5. Using Clutch Spring Compressor, J-4670, Rear Clutch Spring Compressor, J-6129, or an arbor press, and Adapter, J-21664, compress spring retainer and remove snap ring with Snap Ring Pliers, J-8059 or J-5586.

6. Remove tools, spring retainers, and clutch release springs.

7. Remove direct clutch piston from direct clutch housing.

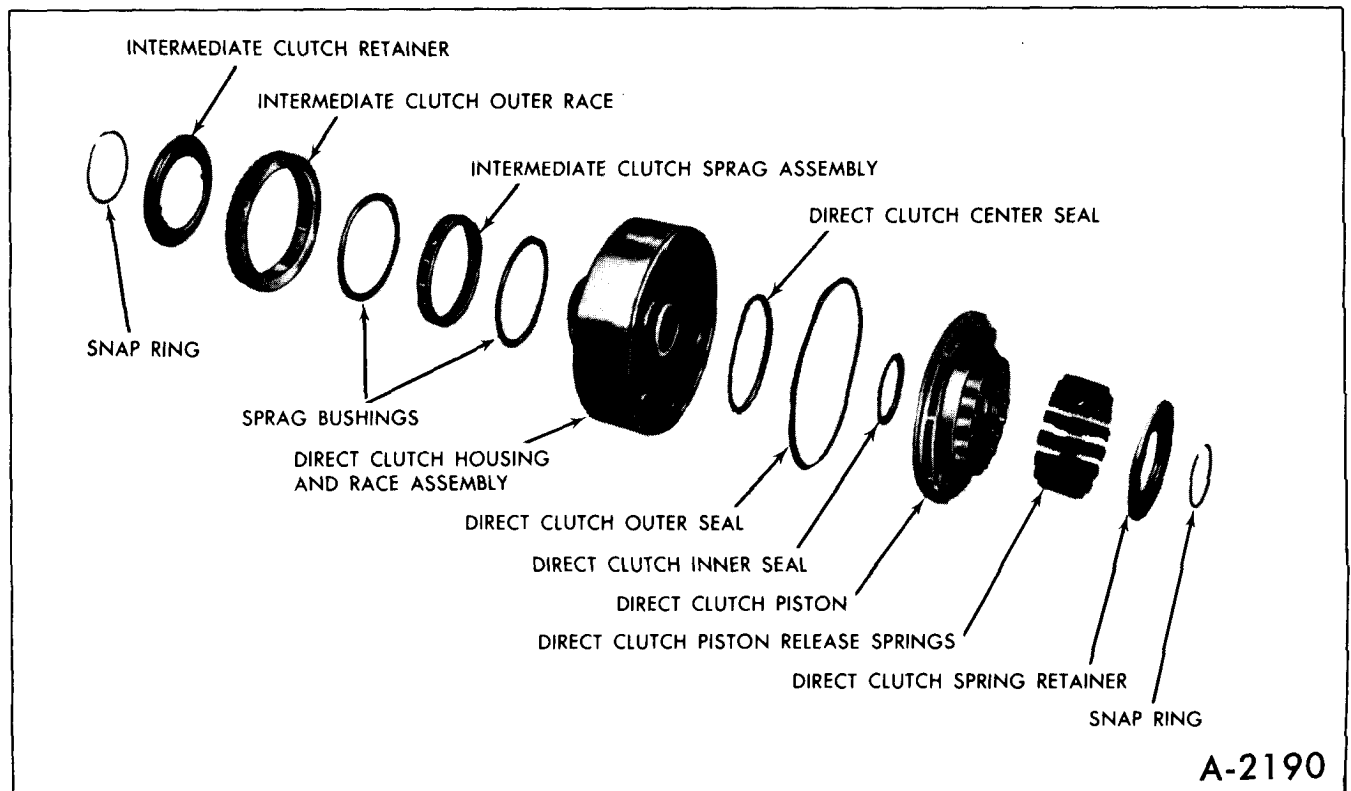

Figure 73—Direct Clutch and Piston

8. Remove inner and outer seals from clutch piston.

9. Remove center piston seal from direct clutch housing.

INSPECTION

1. Inspect sprag assembly for popped or loose sprags.

2. Inspect sprag bushing for wear or distortion.

3. Inspect inner and outer races for scratches or wear.

4. Inspect clutch housing for cracks, wear, proper openings of oil passages and wear on clutch plate drive lugs.

5. Inspect composition faced and steel clutch plates for sign of wear or burning.

6. Inspect backing plate for scratches or other damage.

7. Inspect piston for cracks and free operation of ball check.

8. Inspect springs for collapsed coils or signs of distortion.

NOTE: The 14 direct clutch release springs are not serviced individually. If one or more of these springs require replacement, discard all of them and install the 16 service direct clutch release springs.

ASSEMBLY

1. Lubricate new inner and outer clutch piston seals with transmission fluid. Lubricate seal grooves in direct clutch piston and install seals with lips facing away from spring pockets.

NOTE: Make certain piston has ball check.

2. Lubricate new center seal with transmission fluid. Lubricate seal groove in direct clutch housing and install seal in clutch housing with lip facing up.

3. Place Forward and Direct Clutch Inner Seal Protector, J-21362, over direct clutch hub. Install clutch piston inside Forward and Direct Clutch Piston Installer, J-21409, insert assembly in direct

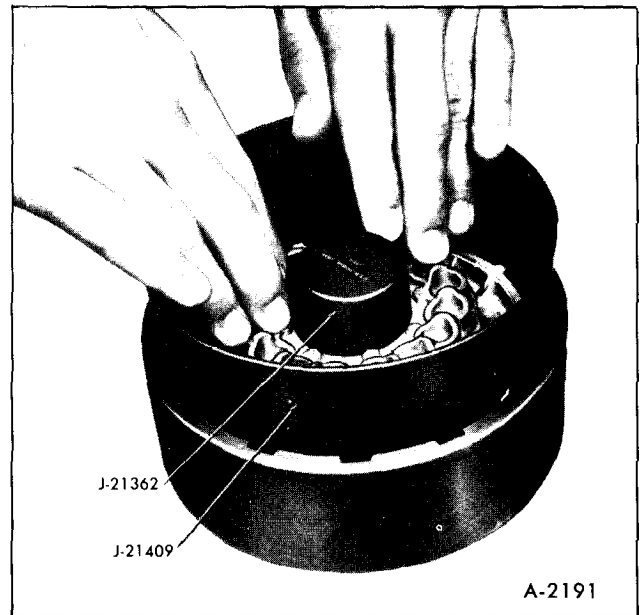

Figure 74—Installing Direct Clutch Piston

clutch housing Figure 74 and install clutch piston by rotating it slightly, in a clockwise direction.

4. Install 16 clutch release springs into spring pockets in clutch piston.

5. Place spring retainer and snap ring over springs.

6. Using Clutch Spring Compressor, J-4670, Rear Clutch Spring Compressor, J-6129, or an arbor press, and Adapter, J-21664, compress spring retainer, being careful that retainer does not get caught in snap ring groove, and install snap ring with Snap Ring Pliers, J-8059 or J-5586. Remove tools.

NOTE: Make certain clutch release springs are not leaning. If necessary, straighten springs with a small screwdriver.

7. Lubricate the five flat and one waved (plate with "U" notch) and steel and six composition clutch plates with transmission fluid and install clutch plates in direct clutch housing. Start with waved steel plate and alternate composition and flat steel clutch plates.

8. Install direct clutch backing plate over clutch plates and install backing plate snap ring.

9. Invert clutch housing and install one sprag bushing, cup side up, around sprag inner race.

10. Install sprag assembly into clutch outer race.

11. With ridge on inner cage of sprag facing up

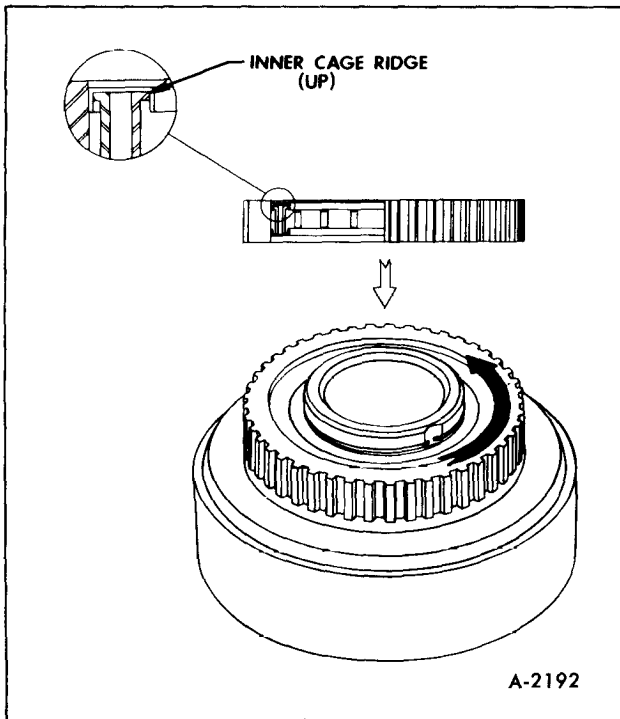

Figure 75—Sprag Rotation

install sprag and outer race on inner race with counterclockwise turning motion.

NOTE: When installed, outer race should turn only counterclockwise, Figure 75.

12. Install sprag bushing, cup side down, over sprag assembly.

13. Install sprag retainer and snap ring.

INSTALL FRONT BAND AND DIRECT CLUTCH ASSEMBLY

1. Inspect front band for cracks or distortion and band ends for damage at anchor lug and apply lug. Also inspect lining for cracks, flaking, burning, and looseness.

2. Install front band with band anchor hole over band anchor pin, and apply lug facing servo hole, Figure 76.

3. Install direct clutch housing and intermediate sprag assembly. Make certain that clutch housing hub bottoms on sun gear shaft and splines on forward end of sun gear shaft are flush with splines in direct clutch housing.

NOTE: It will be necessary to rotate clutch hous-

ing to allow sprag outer race to index with intermediate composition clutch plates. Removal of direct clutch composition-faced and steel plates may be helpful, and applying air pressure through the center support screw to apply the intermediate clutch plates may facilitate assembly.

4. Check operation of direct clutch by applying air pressure through direct clutch passage next to center support bolt.

FORWARD CLUTCH ASSEMBLY DISASSEMBLY (FIGURE 77)

1. Remove forward clutch housing to direct clutch hub snap ring.

2. Remove direct clutch hub.

3. Remove forward clutch hub and one thrust washer from inner side of hub.

4. Remove five composition and five flat and one dished steel clutch plates.

5. Using Clutch Spring Compressor, J-4670, and Adapter, J-21664, compress spring retainer with arbor press and remove snap ring using Snap Ring Pliers, J-8059 or J-5586.

6. Remove tools, spring retainer and 16 clutch release springs. Keep springs separate from direct clutch springs.

7. Remove forward clutch piston from forward clutch housing.

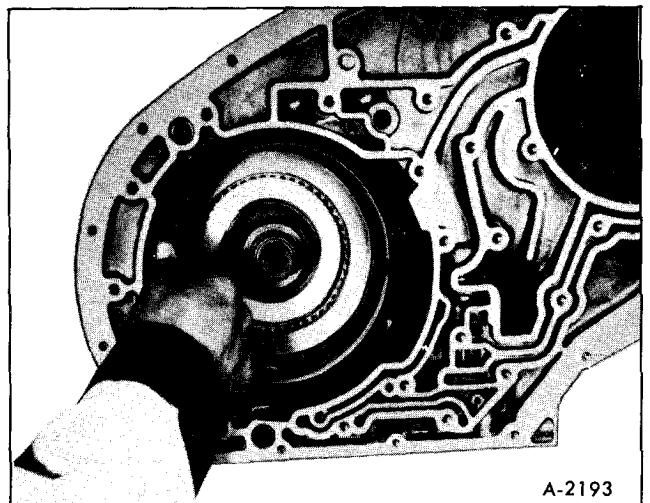

Figure 76—Front Band Installation

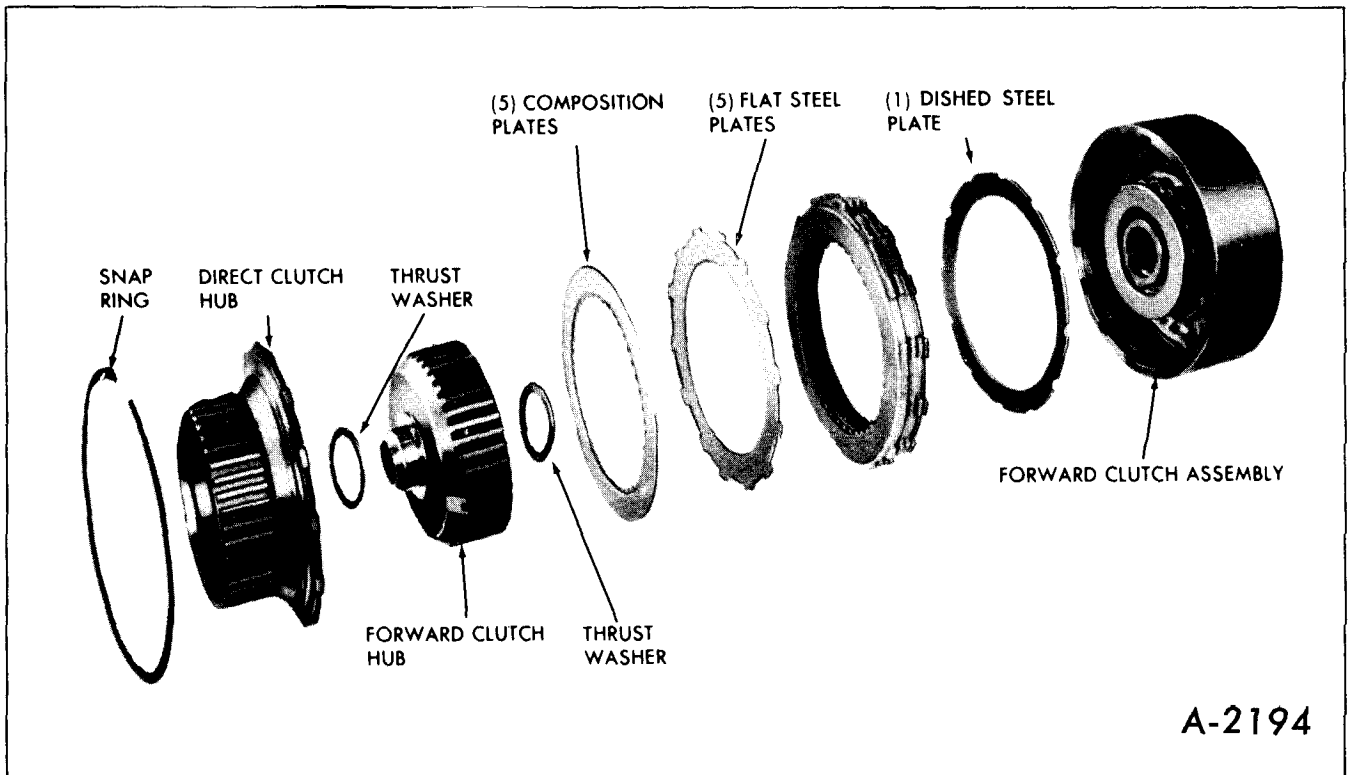

Figure 77-Forward Clutch Components

8. Remove inner and outer seals from clutch piston.

9. Remove center piston seal from forward clutch housing.

INSPECTION

1. Inspect composition-faced and steel clutch plates for signs of burning, scoring or wear.

2. Inspect release springs for collapsed coils or signs of distortion.

3. Inspect clutch hubs for worn splines, proper lubrication holes, and thrust faces.

4. Inspect piston for cracks.

5. Inspect clutch housing for wear, scoring, cracks and open oil passages.

ASSEMBLY (FIGURE 78)

1. Lubricate new inner and outer clutch piston seals with transmission fluid. Lubricate seal grooves

in forward clutch piston with petrolatum and install seals with lips facing away from spring pockets.

NOTE: The forward and direct clutch pistons have identical inside and outside diameters. Therefore, extreme care should be exercised during reassembly to assure the proper piston be installed in the clutch assemblies. The forward clutch piston can be identified by the absence of a check ball in the clutch apply face of the piston.

2. Lubricate new center piston seal with transmission fluid. Lubricate seal groove in forward clutch housing with petrolatum and install seal into clutch housing with lip facing up.

3. Place Forward and Direct Clutch Inner Seal Protector, J-21362, over forward clutch hub. Install clutch piston inside Forward and Direct Clutch Piston Installer, J-21409, insert assembly in forward clutch housing, and install clutch piston by rotating it slightly in a clockwise direction until seated.

4. Install sixteen clutch release springs into spring pockets in clutch piston.

5. Using Clutch Spring Compressor, J-4670, and Adapter, J-21664, compress spring retainer with arbor press, being careful that retainer does not catch in snap ring groove, and install snap ring using Snap Ring Pliers, J-8059 or J-5586, and remove tools.

A-2194

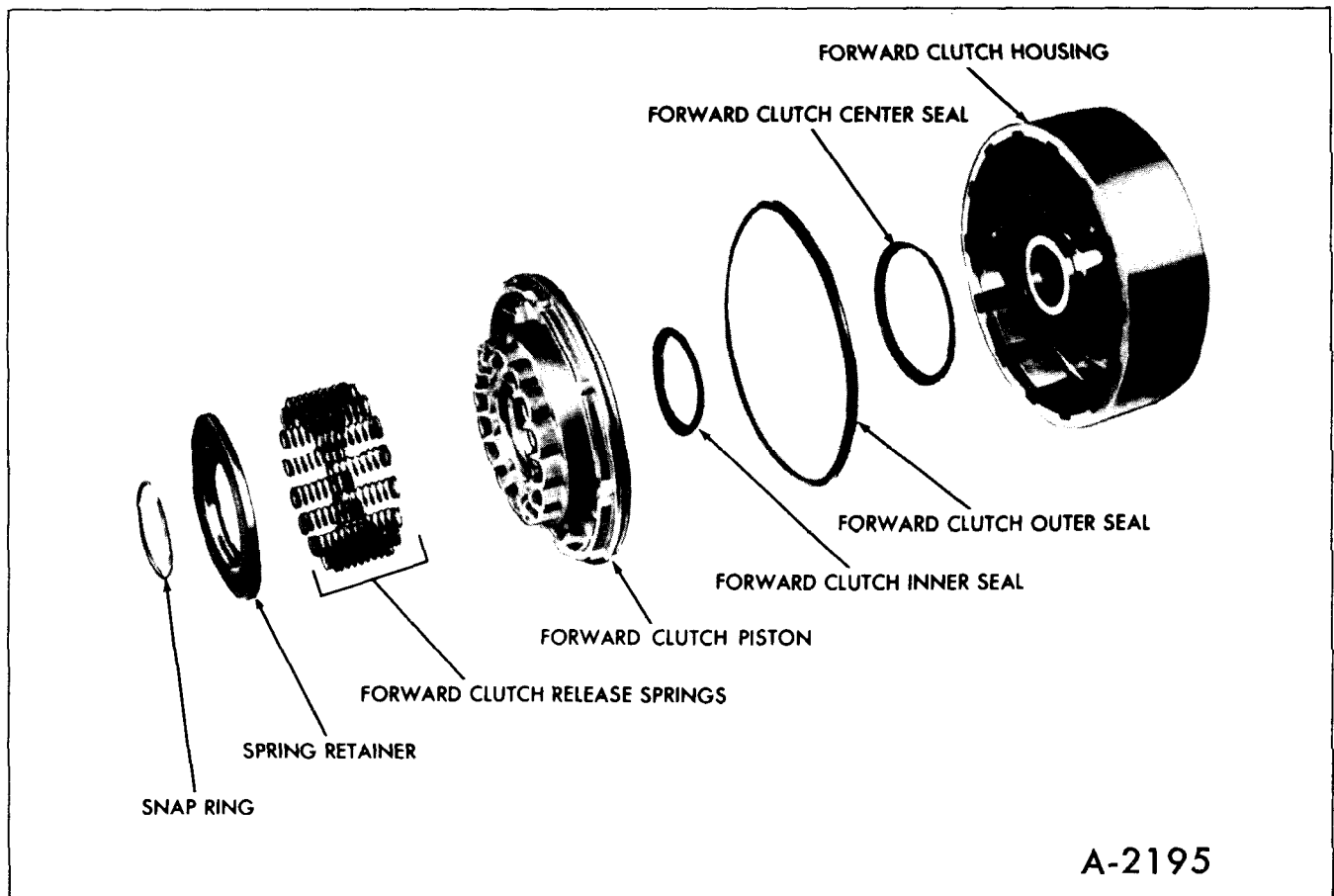

A-2195

Figure 78—Forward Clutch Piston Components

CAUTION: Make certain clutch release springs are not leaning. If necessary, straighten with a small screwdriver.

6. Remove forward clutch assembly from arbor press and place on work bench.

7. Install the forward clutch hub thrust washers on the forward clutch hub. Retain with petrolatum.

8. Install forward clutch hub in forward clutch housing.

9. Lubricate the dished and five flat steel and five composition clutch plates with transmission fluid and install clutch plates in forward clutch housing. Start with dished steel plate (O.D. up) and place a flat steel plate on top of the dished steel plate. Then alternate composition and flat steel clutch plates.

10. Install direct clutch hub in forward clutch housing over clutch plates, and install snap ring.

11. Air check forward clutch and piston operation, Figure 79.

INSTALL FORWARD CLUTCH

1. Install Front Unit End Play Checking Tool, J-22241 into forward clutch, Figure 45.

2. Install forward clutch assembly into transmission, making certain main shaft goes into forward

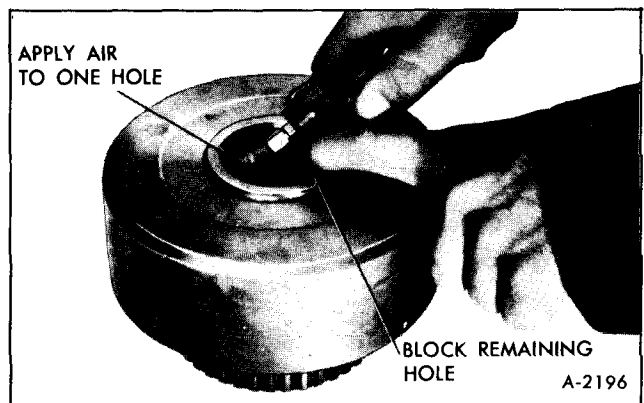

Figure 79—Air Check Forward Clutch Piston

clutch hub. It will be necessary to rotate clutch housing to allow direct clutch driving hub to index with direct clutch composition-faced plates.

3. Remove Front Unit End Play Checking Tool, J-22241.

INSTALL PUMP COVER PLATE

1. Install new pump cover plate gasket on transmission.

2. Install pump cover plate on transmission and install attaching bolts per bolt chart, Figure 80.

NOTE: Do not install pump attaching bolts (F) or single bolt (E) in pump cover plate at this time.

3. Using the driven sprocket as a driver rotate the forward clutch.

NOTE: If the forward clutch housing cannot be rotated as the pump cover plate is being pulled into place, the forward or direct clutch housings have not been properly installed to index with all the clutch plates. This condition must be corrected before the pump cover plate is pulled fully into place.

4. Torque all bolts to 20 foot-pounds.

5. Repeat front unit end play check as described.

6. Install remaining bolt (E) in driven support housing, tightening to 20 foot-pounds.

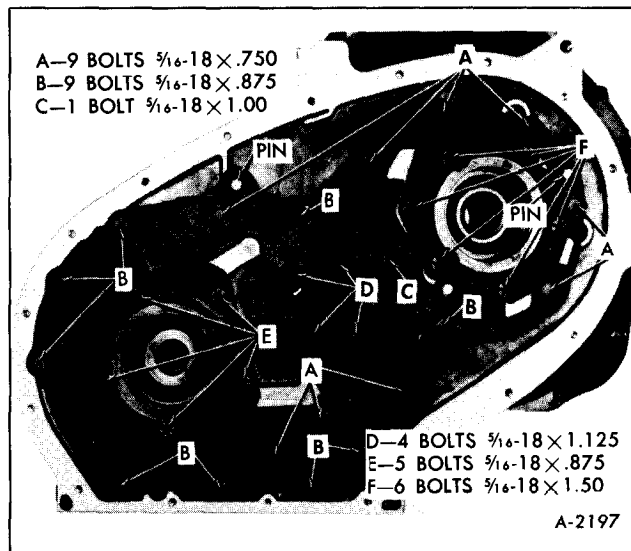

Figure 80-Pump Cover Plate Screws

OIL PUMP

DISASSEMBLY

1. Mark drive and driven gears for reassembly in same position and remove the pump body.

NOTE: Installing the gears in the same position as removed will assure the quietest operation, as the gear teeth will mesh in the established wear pattern.

2. Remove drive and driven gears from pump body.

3. Remove and discard pump body to case square-cut O-ring seal.

INSPECTION

1. Using tip of finger, inspect gear pocket and crescent for nicks, burrs, scoring or galling.

2. Inspect drive gear for nicks, burrs, scoring, or galling.

3. Inspect driven gear for nicks, burrs, scoring, or galling.

4. Place pump gears in pump body and check pump body face to gear face clearance. Clearance should be .0013"-.0035".

5. Check face of pump body for nicks, burrs, scoring, or galling.

6. Check pump body face flatness. Overall flatness should be .000" to .002".

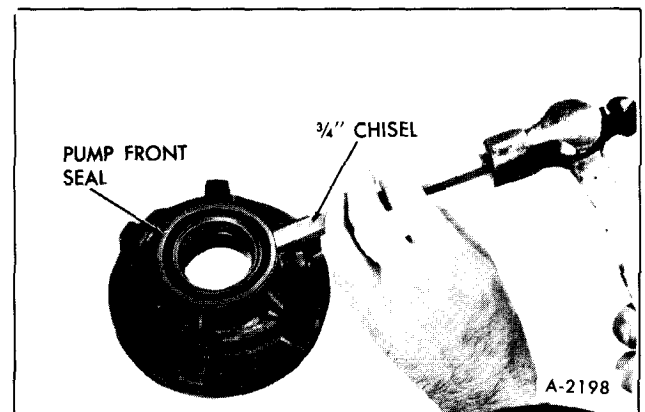

Figure 81-Removing Pump Front Seal

7. Inspect bushing for nicks, burrs, scoring, galling, out-of-round, or excessive wear.

NOTE: To check for out-of-round, install pump body on the converter hub and look for eccentricity between pump bushing and converter hub.

8. Check for damaged pump cover plate bolt holes.

9. Inspect front seal for damage. If replacement of front seal is necessary, use a standard 3/4" cold chisel and pry front seal from pump body, Figure 81.

ASSEMBLY

1. If necessary, install a new front seal, using Pump Oil Seal Installer, J-21359, to drive seal into place. Use a non-hardening sealer on outside of seal before installing into pump, Figure 82.

2. Install new pump to case square-cut O-ring seal.

3. Install driven gear into pump body with alignment mark up.

4. Install drive gear into pump body with drive tangs up, Figure 83.

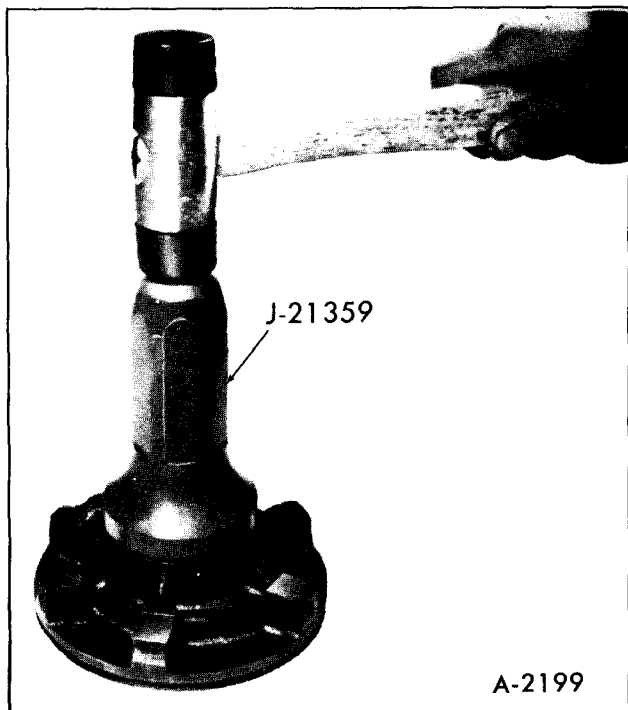

Figure 82—Installing Pump Front Seal

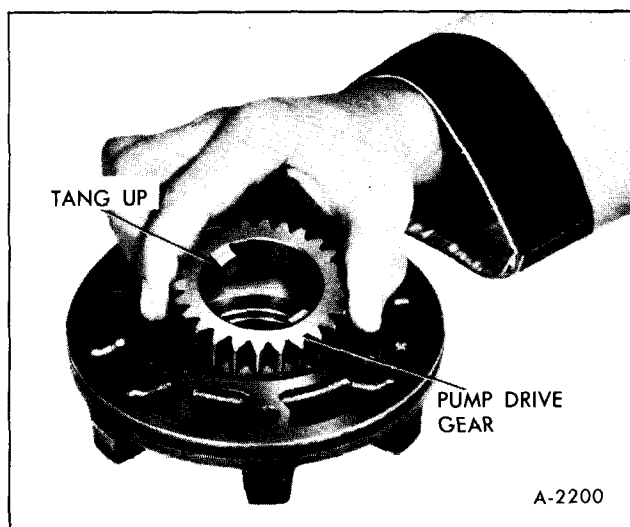

Figure 83—Installing Pump Drive Gear

NOTE: Drive gear should always be installed with counterbore down.

INSTALLATION

1. Rotate transmission in holding fixture base so that cored oil passages are up.

2. Install pump assembly over stator shaft and position to drive support housing, rotating pump as necessary to align holes in pump cover plate with pump attaching bolt holes.

3. Install six retaining bolts (F), finger tight, Figure 80.

4. Tighten pump attaching bolts to 20 ft. lbs.

INSTALL SPROCKETS, LINK ASSEMBLY AND SPROCKET COVER

1. Place link belt around the drive and driven sprockets so that the links engage the teeth of the sprockets, colored guide link which has etched numerals facing link cover.

2. Simultaneously place link belt, drive and driven sprockets into support housing.

3. Using a plastic mallet, gently seat the sprocket bearing assemblies into the support housings.

4. Install sprocket assembly to support housing snap rings using J-4646 snap ring pliers.

5. Install new case to cover and plate assembly sprocket housing gasket.

6. Install sprocket housing cover and plate assembly and eighteen attaching bolts. Torque bolts to 8 ft. lbs.

NOTE: One sprocket cover housing attaching bolt is 1/4 inch longer. This bolt must be installed in the tapped hole located directly over the cooler fittings on the transmission case.

DETENT LEVER, MANUAL SHAFT, PARKING LINKAGE, REAR SERVO, FRONT SERVO, CHECK BALLS, AND CONTROL VALVE SPACER

INSPECT DETENT LEVER, MANUAL SHAFT, AND PARKING LINKAGE

1. Inspect parking actuator rod for cracks, or broken spring retainer lugs.
2. Inspect actuator spring for damage.
3. Inspect actuator for a free fit on actuator rod.
4. Inspect parking pawl for cracks or wear.
5. Inspect manual shaft for damaged threads.
6. Inspect inside detent lever for cracks or a loose pin.
7. Inspect parking pawl return spring for deformed coils or ends.
8. Inspect parking bracket for cracks or wear.
9. Inspect detent spring and roller assembly.

INSTALL DETENT LEVER, MANUAL SHAFT AND PARKING LINKAGE

1. Install parking pawl (tooth toward inside of case), pawl return spring and parking pawl shaft into case, Figure 84.

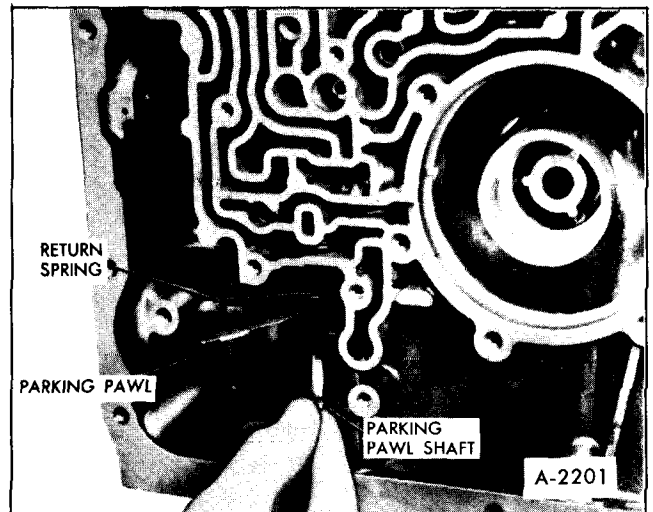

Figure 84—Installing Parking Pawl

2. Install parking pawl shaft retaining pin into case hole.
3. Install parking bracket into case, tightening attaching screws to 18 ft. lbs.
4. Install a new manual shaft O-ring seal on manual shaft.
5. Install the actuator rod plunger under the parking bracket and over the parking pawl and through hole in detent lever. Position detent lever in transmission case.
6. Install the manual shaft assembly through the retaining lock nut on manual shaft, Figure 85.
7. Install manual shaft retaining pin into case, long smooth end first.
8. Torque lock nut to 18 ft. lbs.

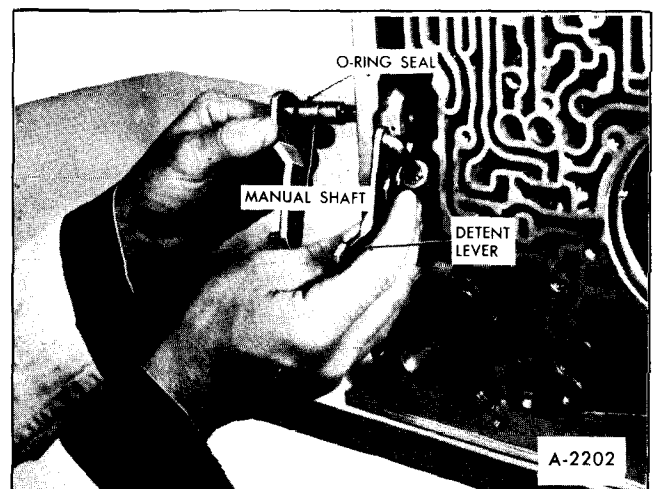

Figure 85—Installing Manual Shaft

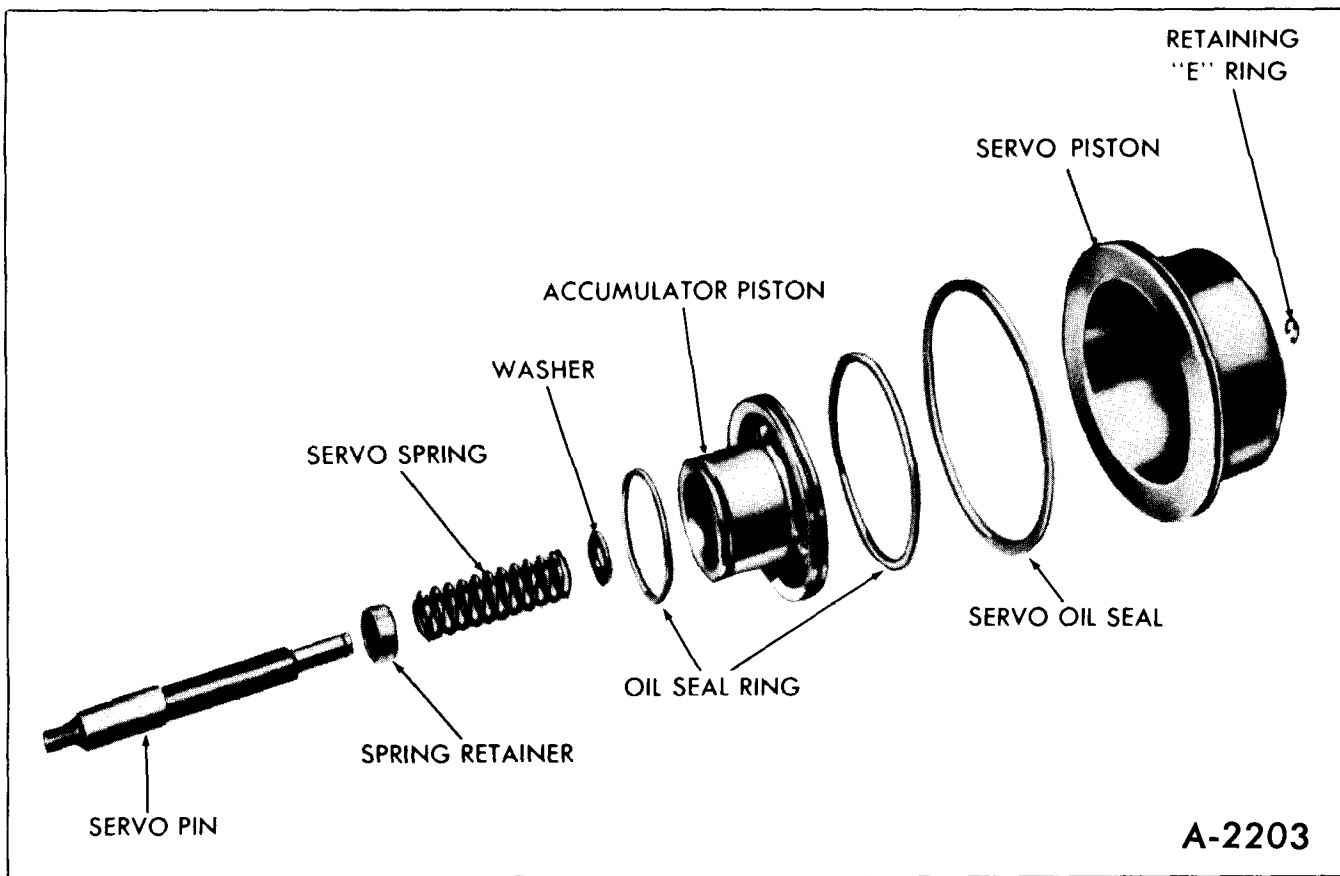

Figure 86—Rear Servo and Accumulator

DISASSEMBLE REAR SERVO ASSEMBLY (FIGURE 86)

1. Remove rear accumulator piston from rear servo piston.
2. Remove E-ring retaining rear servo piston to band apply pin.
3. Remove rear servo piston and seal from band apply pin.
4. Remove washer, spring and retainer.

INSPECT REAR SERVO

1. Check freeness of oil seal rings in accumulator piston grooves.

NOTE: Do not remove the teflon oil seal rings from the rear accumulator piston, unless the oil seal rings require replacement.

If the teflon inner oil seal ring. (small diameter) requires replacement, for service, use the aluminum oil seal ring.

The rear accumulator piston, large diameter ring groove depth, is machined shallower to take the large teflon oil seal ring; if this requires replacement, use only the teflon oil seal ring.

2. Inspect fit of band apply pin in servo piston.
3. Inspect band apply pin for scores or cracks.
4. Inspect band apply pin for proper size as determined by pin selection check.

ASSEMBLE REAR SERVO

1. Install spring retainer, cup side first, servo pin spring and washer on servo pin.
2. Install servo piston on pin and secure with E-ring retainer.

3. If removed, install oil seal ring on servo piston.
4. If removed, install inner and outer oil rings on accumulator piston.
5. Install accumulator piston into bore of servo piston.

INSTALL REAR SERVO

NOTE: If the transmission is in the vehicle, a sheet metal bracket will be required to hold the rear servo assembly, front servo assembly, check balls, valve body to spacer plate gasket and valve body spacer plate, until the control valve assembly is installed. See Figure 87.

1. Lubricate inner and outer rear servo bores in transmission case with transmission fluid and install rear accumulator spring in servo inner bore.

NOTE: Before installing rear servo assembly, make certain that rear band apply lug is aligned with servo pin bore in transmission case. Otherwise servo pin will not apply band.

2. Position rear servo assembly in transmission case bore.
3. Press down on rear servo assembly, making certain oil seal ring is properly seated in case bore.

INSPECT FRONT SERVO

NOTE: See Figure 88. Do not remove the teflon

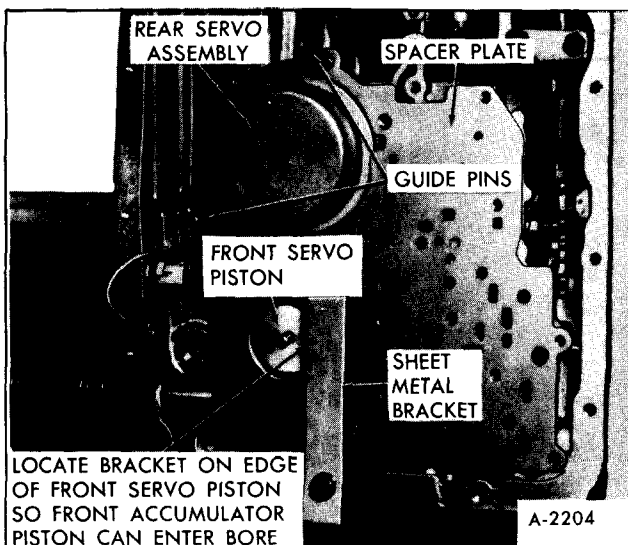

Figure 87—Spacer Plate Holding Bracket

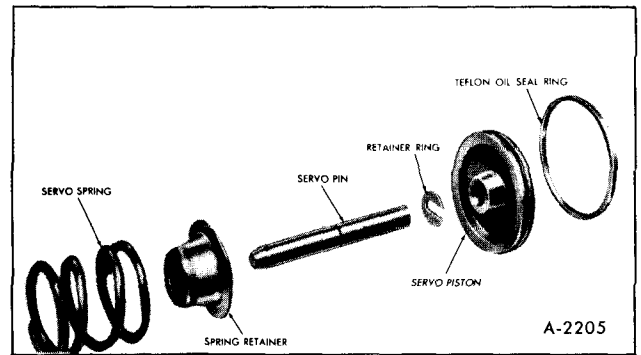

Figure 88—Front Servo Components

oil seal ring from the front accumulator piston unless the oil seal ring requires replacement. For service, the oil seal ring will be cast iron.

1. Inspect servo pin for damage.
2. Inspect piston oil ring for damage.
3. Inspect piston for cracks or porosity.
4. Check fit of servo pin in piston and case.

INSTALL FRONT SERVO ASSEMBLY

Reassemble parts of front servo, making sure tapered end of servo pin is pointed through the spring and spring retainer, and install in bore in case. Make sure the retainer ring is installed in the servo pin groove.

NOTE: The teflon ring allows the front servo piston to slide very freely in the case. The free fit of the ring in the bore is a normal characteristic and does not indicate leakage during operation. The teflon ring should only be replaced if it shows damage or if evidence of leakage during operation exists.

INSTALL CHECK BALLS AND CONTROL VALVE SPACER

1. Install seven check balls in cored passages, Figure 89. (Use petrolatum to retain balls in case.)

NOTE: If transmission is in vehicle, place check balls into ball seat pockets on spacer plate.

2. Install valve body spacer to case gasket on transmission case.

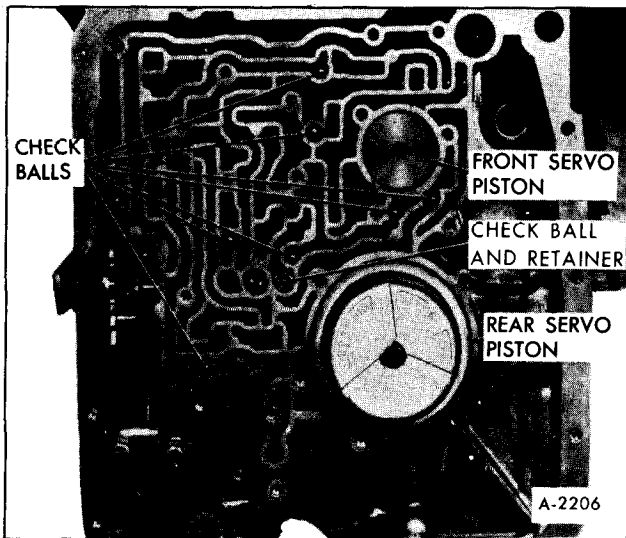

Figure 89—Check Ball Location

3. Install valve body spacer on transmission.

NOTE: Valve body spacer to case gasket should extend approximately 1/8 inch beyond the spacer plate, over the void case channel, Figure 90. If service gaskets are being installed, the valve body spacer to case gasket has an extension which will cover the void case channel.

4. Install valve body to spacer gasket.
5. Install guide pins.

CONTROL VALVE ASSEMBLY (FIGURE 91)

DISASSEMBLY

When disassembling control valve, make certain that springs are accurately identified so that they can be properly reassembled.

1. Position control valve assembly with cored face down.
2. Remove two screws securing detent solenoid to control valve body and remove downshift solenoid and gasket.
3. Position control valve assembly with cored face up and accumulator pocket on bottom.
4. Remove manual valve from upper bore.
5. Install Control Valve Accumulator Piston In-

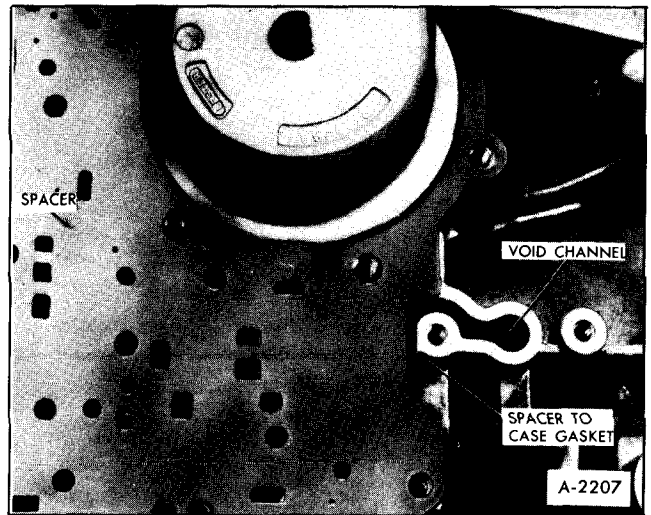

Figure 90—Valve Body Spacer-to-Case Gasket

staller, J-21885, on accumulator piston, compress piston and remove E-ring retainer, Figure 92.

6. Remove Installer, J-21885, and remove accumulator piston and spring.

7. Using pin punch, remove retaining pin from lower left bore, pressing on pin from outer side of valve body. Remove 2-3 modulator bushing, 2-3 shift valve spring, 2-3 modulator valve, 3-2 intermediate spring and 2-3 shift valve from left bore.

NOTE: 2-3 modulator valve will be inside of 2-3 modulator bushing.

8. Using pin punch, remove retaining pin from lower center left bore, pressing on pin from outer side of valve body. Remove 1-2 modulator bushing, 1-2 modulator spring, 1-2 modulator valve and 1-2 shift valve from lower left center bore.

NOTE: 1-2 regulator valve and spring and 1-2 detent valve may be inside of 1-2 modulator bushing.

9. Using pin punch, remove retainer pin from upper left center bore by pressing on outer side of valve body.

WARNING: HOLD HAND OVER BORE WHEN REMOVING RETAINER PIN AS DETENT REGULATOR VALVE SPRING MAY FORCE OTHER COMPONENTS OUT OF BORE.

10. Remove bore plug, detent valve, detent regulator valve, spacer and detent regulator valve spring from upper left center bore.

11. Remove retaining pin from bottom bore on left side by prying out with a pair of long nose pliers.

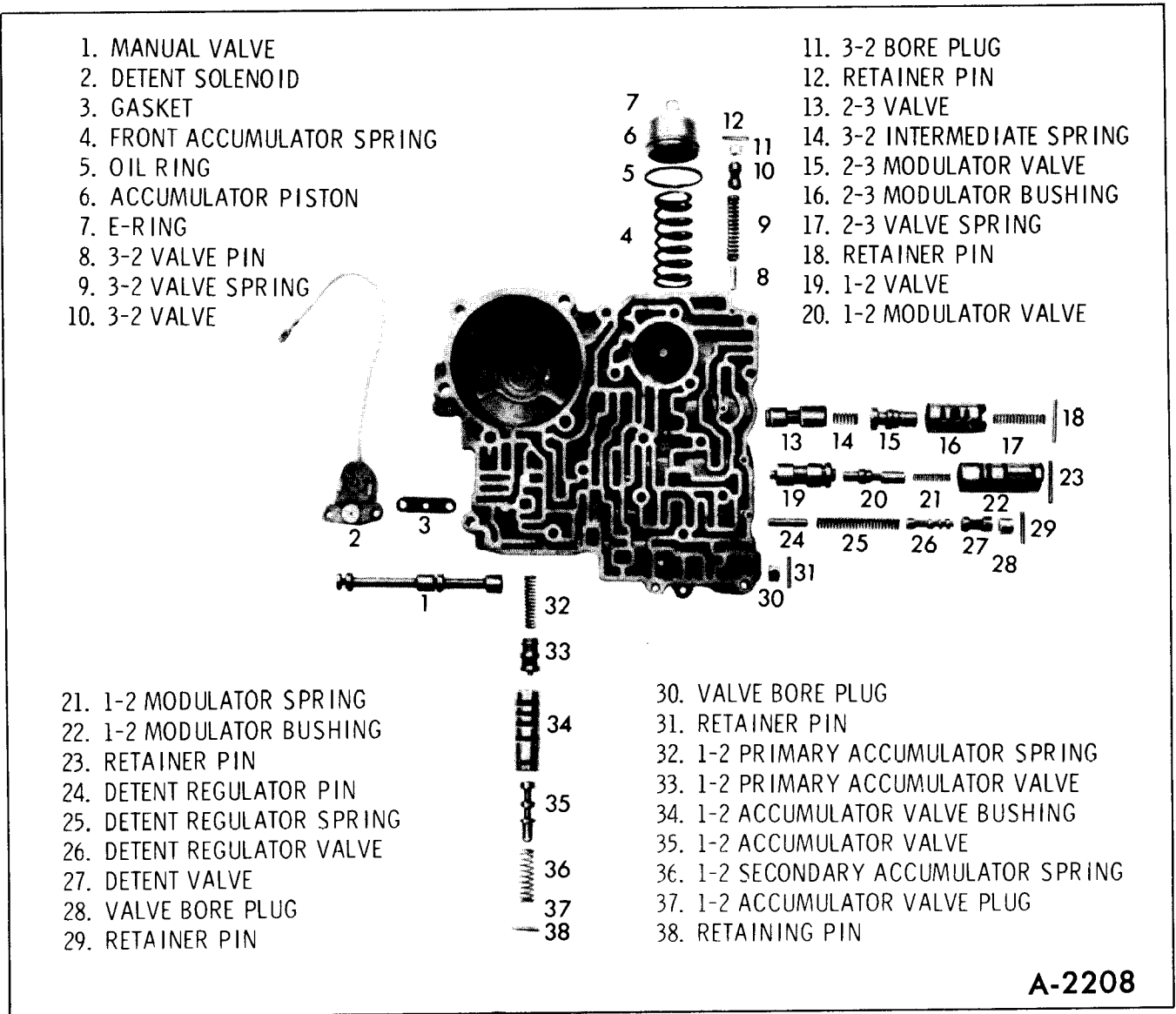

Figure 91-Control Valve

WARNING: HOLD HAND OVER BORE WHEN REMOVING RETAINER PIN AS 3-2 VALVE SPRING MAY FORCE BORE PLUG OUT.

12. Remove bore plug, 3-2 valve, spring and spacer from bottom left bore.

13. Remove retaining pin from top bore by prying out with long nose pliers from outer side of valve body.

WARNING: HOLD HAND OVER BORE WHEN REMOVING RETAINER PIN AS ACCUMULATOR SPRINGS MAY FORCE OTHER COMPONENTS OUT OF BORE.

14. Remove bore plug, 1-2 accumulator valve

bushing, 1-2 accumulator valve and secondary spring, 1-2 accumulator primary valve and spring.

INSPECTION

NOTE: Do not remove the teflon oil seal ring from the front accumulator piston unless the oil seal ring requires replacement. For service, the oil seal ring will be aluminum.

1. Wash control valve body, valves, and other parts in clean solvent.

CAUTION: Do not allow valves to bump

A-2208

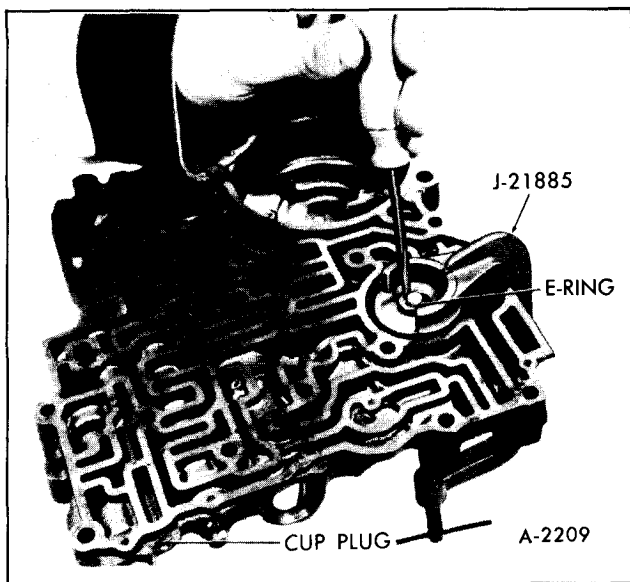

Figure 92—Removing Front Accumulator

together, as this might cause nicks and burrs.

2. Inspect all valves and bushings carefully to make sure that they are free from dirt and are not damaged in any respect. If burrs are present, they should be removed with a fine stone or fine grade of crocus cloth and light oil. Be careful not to round off shoulders of valves.

3. All valves and bushings should be tested in their individual bores to make certain that free movement can be obtained. All valves should fall freely of their own weight with a slight tapping action on the body. In checking be careful to prevent valve damage in any way.

4. The manual valve is the only valve that can be serviced separately. If other valves are defective or damaged beyond repair, a new control valve assembly should be installed.

5. Inspect body for cracks or scored bores.

6. Check all springs for distortion or collapsed coils.

7. Inspect piston and oil ring for damage.

ASSEMBLY (FIGURE 91)

1. Position control valve body and cored face up and accumulator pocket on bottom.

2. Install the 1-2 primary accumulator spring

into the 1-2 primary accumulator valve and install both, spring first, into top bore, using a retainer pin to temporarily hold valves and spring in their operating position.

3. Install the 1-2 accumulator valve, wide land first, into the 1-2 accumulator bushing.

4. Install the 1-2 accumulator valve bushing into the top bore, aligning the square port on the end of the bushing with hole for retaining pin.

5. Install the 1-2 secondary accumulator spring and the 1-2 bore plug into bushing.

6. Compress 1-2 accumulator valve train, install grooved retaining pin, grooved end entering hole last from outer side of valve body, pressing pin flush with valve body. Remove the temporary retaining pin.

7. Insert spacer inside of 3-2 valve spring and install spring and spacer in bottom left bore.

8. Install 3-2 valve in bottom left bore.

9. Compressing 3-2 valve spring, install bore plug, hole end out, and secure with grooved retaining pin from cored side of valve body.

10. Insert spacer inside of detent regulator valve spring and install spring and spacer into upper left center bore, making certain spring seats in bottom of bore.

11. Compress detent regulator valve spring and hold with a small screwdriver placed between end of spring and wall on cored side of valve body.

12. Install detent regulator valve, stem end out, and detent valve, small land first, into upper left center bore.

13. Insert bore plug, hole out, into upper left center bore and, pressing inward on bore plug, remove screwdriver and install remaining pin from cored side of valve body.

14. Install 1-2 shift valve, longer stem end first, in lower left center bore, making certain valve seats in bottom of bore.

15. Install 1-2 regulator valve and spring and 1-2 detent valve into 1-2 modulator bushing. Install assembly into lower left center bore of control valve body, open end of bushing first.

16. Compress bushing against spring and secure with retaining pin from cored side of control valve body.

17. Install 3-2 intermediate spring in open end of

2-3 shift valve, and install valve and spring, valve first, into lower left bore. Make certain valve seats in bottom of bore.

18. Install 2-3 modulator valve, hole end first, into 2-3 modulator bushing and install both parts in lower left bore.

19. Install 2-3 shift valve spring into hole in 2-3 modulator valve, and compressing spring, secure with retaining pin from cored side of control valve.

20. Position front accumulator spring and piston into valve body and install Control Valve Accumulator Piston Installer, J-21885, on piston. Compress spring and piston, aligning spring and piston with bore, Figure 92.

CAUTION: Make certain that piston pin is correctly aligned with hole in piston and that oil seal ring does not catch on lip of bore when installing piston.

21. Secure piston and spring with E-ring retainer and remove Installer, J-21885.

22. Install manual valve into top bore.

23. Placing control valve assembly on cored surface, position downshift solenoid gasket and detent solenoid on valve body.

24. Install downshift solenoid attaching screws.

25. Install governor drive pipe into control valve body in bore by rear servo cover.

26. Install two governor screen assemblies with open end up into case.

INSTALL CONTROL VALVE ASSEMBLY

1. Using two guide pins, install control valve as-

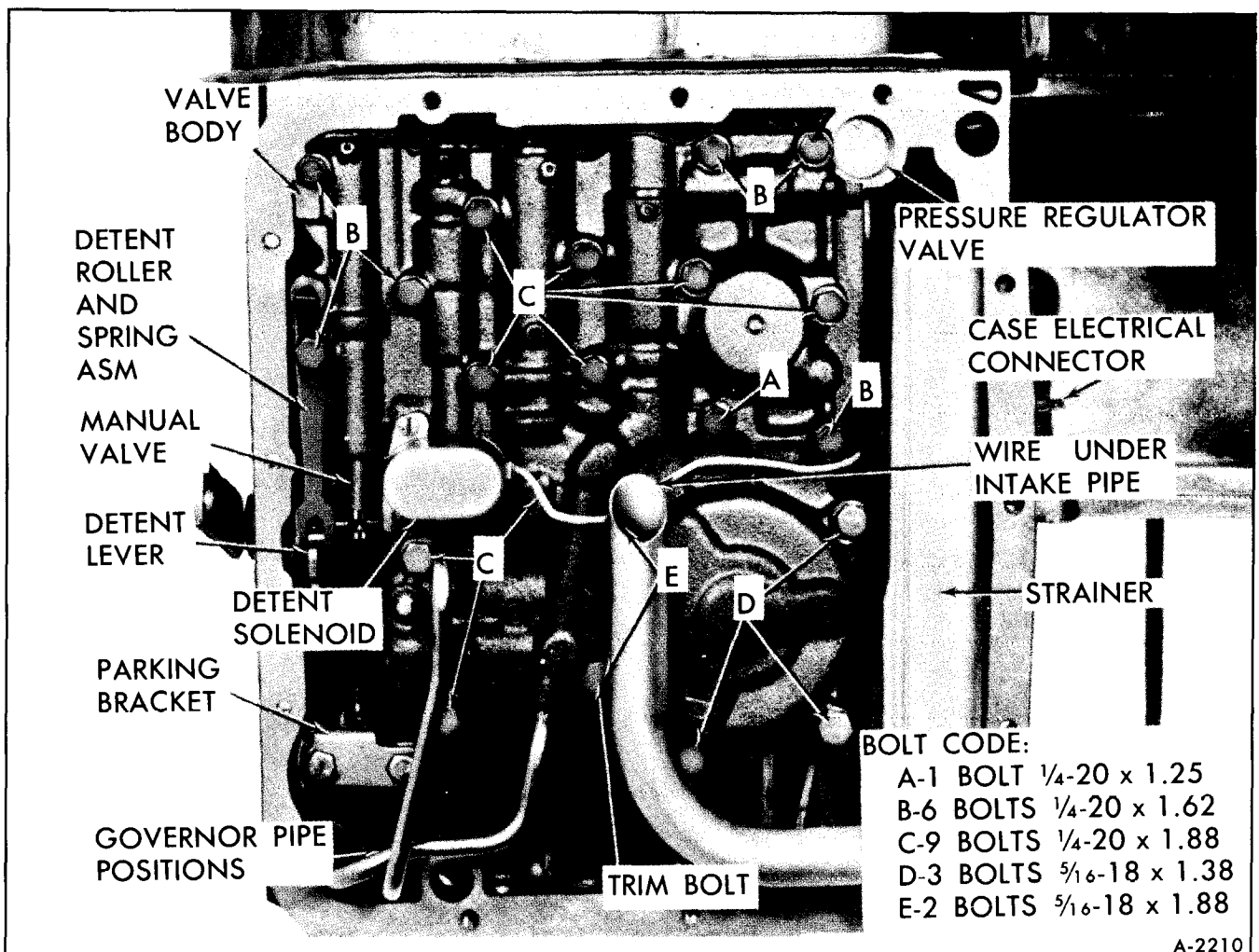

Figure 93—Control Valve Screws

sembly and governor pipe on transmission. Make certain gaskets and spacer do not become mispositioned.

NOTE: Check manual valve to make sure it is indexed properly with pin on detent lever and governor pipe to make certain it is properly seated in case hole.

2. Remove guide pins and install control valve assembly attaching screws, eliminating detent roller and spring assembly attaching screw. Torque bolts to 8 foot-pounds, Figure 93.

3. Install detent roller and spring assembly and attaching screw. Tighten screw to 8 foot-pounds.

4. Install detent terminal and lead wire to case connector.

5. Install governor feed pipe in transmission case and control valve body.

NOTE: Make certain that governor feed pipe is seated in bores in case and valve body.

PRESSURE REGULATOR VALVE, INTAKE PIPE AND FILTER ASSEMBLY, BOTTOM PAN, MODULATOR VALVE AND MODULATOR

INSTALL PRESSURE REGULATOR VALVE

1. Install spring retainer on pressure regulator spring. Also install spacers if previously removed, Figure 94.

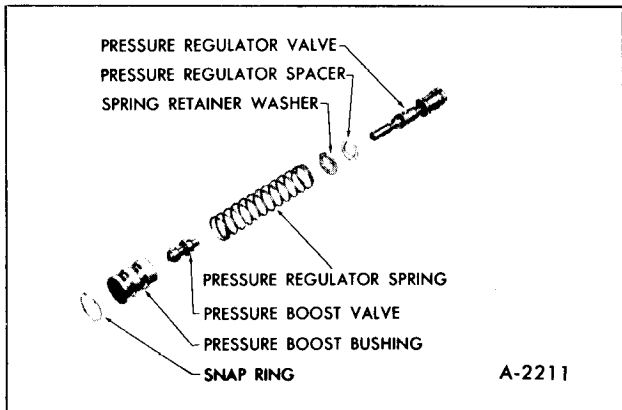

Figure 94-Pressure Regulator Valve

2. Install pressure regulator valve on spring, stem end first.

3. Install boost valve into bushing, stem end out, and stack parts so that pressure regulator spring is against valve bushing.

4. Install complete assembly, pressure regulator valve first, into pressure regulator valve bore, being careful not to drop parts during installation.

5. Using a screwdriver or steel rod, compress regulator boost valve bushing against pressure regulator spring until it is beyond snap ring groove, and install snap ring using Snap Ring Pliers, J-5403 (#21), Figure 35.

NOTE: To facilitate installation of snap ring, encircle it around screwdriver or steel rod, compress tangs with snap ring pliers, and slide snap ring into ring groove in valve bore.

INSTALL INTAKE PIPE AND FILTER ASSEMBLY AND BOTTOM PAN

1. Install new intake pipe O-ring into pipe bore in transmission case and install intake pipe and filter assembly.

2. Install new bottom pan gasket on transmission case and install bottom pan.

3. Install 13 bottom pan attaching screws. Tighten screws to 12 foot-pounds.

INSPECT VACUUM MODULATOR AND VALVE

1. Inspect vacuum modulator for any signs of bending or distortion.

2. Inspect O-ring seat for damage.

3. Inspect modulator valve for nicks or damage.

4. Check freeness of valve operation in case bore.

5. Check modulator for damaged bellows. Modulator plunger is under approximately 16 pounds pressure. If bellows is damaged, plunger will have very little pressure.

INSTALL MODULATOR VALVE AND VACUUM MODULATOR

1. Install modulator valve into case with stem end out.
2. Install new O-ring on vacuum modulator.
3. Install vacuum modulator into case with vacuum hose pipe facing case connector.
4. Install modulator retainer with curved side of tangs inboard and install attaching screw. Tighten screw to 18 foot-pounds.

GOVERNOR ASSEMBLY

NOTE: All components of the governor assembly, with the exception of the driven gear, are a select fit and each assembly is factory calibrated. The governor, including the driven gear, is serviced as a complete assembly. However, the driven gear can also be serviced separately.

GOVERNOR INSPECTION

1. Wash in cleaning solvent, and blow out all passages.
2. Inspect governor sleeve for nicks, burrs, scoring or galling.
3. Check governor sleeve for free operation in bore of transmission case.
4. Check governor valve for free operation in bore of governor sleeve.
5. Inspect governor driven gear for nicks, burrs, or damage.
6. Check governor driven gear for looseness in governor sleeve.
7. Inspect speedometer drive gear for nicks, burrs, or damage.
8. Check speedometer drive gear for looseness on governor sleeve.
9. Inspect governor springs for distortion or damage.
10. Check governor weights for free operation in their retainers.

11. Check valve opening at entry and exhaust (.020" minimum).

GOVERNOR DRIVEN GEAR REPLACEMENT

To facilitate governor repair in the field, governor driven gear and replacement pins are available for service use. The service package contains a nylon driven gear, two governor weight retaining pins and one governor gear retainer split pin. Replacement of gear must be performed with care in the following manner:

1. Place governor sleeve on a block of wood and drive retaining pin out, using a small punch or 1/8" drill rod.
2. Remove governor driven gear as follows:
 - a. Insert governor driven gear in a vice.
 - b. Firmly grip governor sleeve with hands and twisting and pulling at the same time, pull governor sleeve away from the governor driven gear.
 - c. Discard governor driven gear.
3. Remove generator valve and wash all parts in cleaning solvent and blow off parts.
4. Install governor valve, end with holes last, into governor sleeve.
5. Support governor on 7/64" plates, installed in exhaust slots of sleeve, position new gear in sleeve and with a 7/16" socket, press gear into sleeve until seated. See Figure 95.

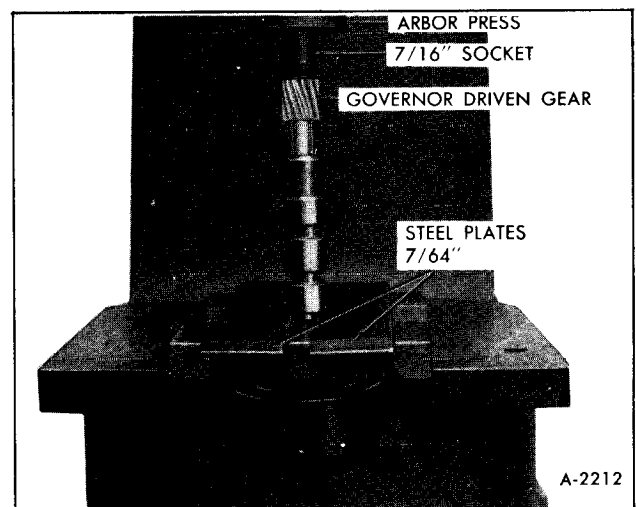

Figure 95—Installing Governor Gear

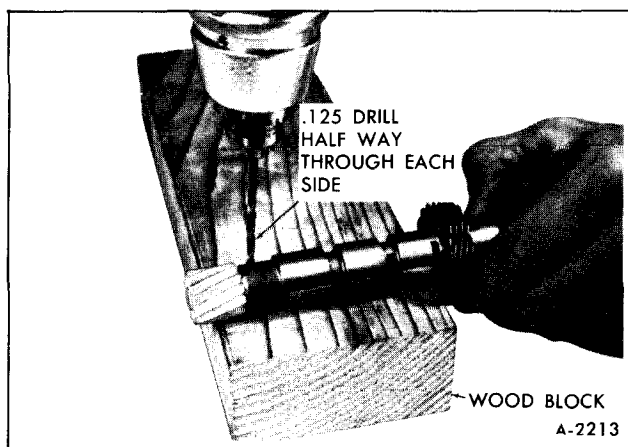

Figure 96—Drilling Governor Gear Shaft

6. Place governor sleeve on a block of wood and with a 1/8" drill, drill half way through each side of gear; drill through existing hole. See Figure 96.

7. Install split retaining pin, making sure each end is slightly below top of hole.

CAUTION: *Extreme care must be taken to prevent damaging the parts.*

8. Stake both ends of pin hole, two places.

9. Thoroughly wash governor assembly in cleaning solvent and blow out all passages.

INSTALL GOVERNOR

1. Rotate transmission in Holding Fixture Base so that governor bore is up.

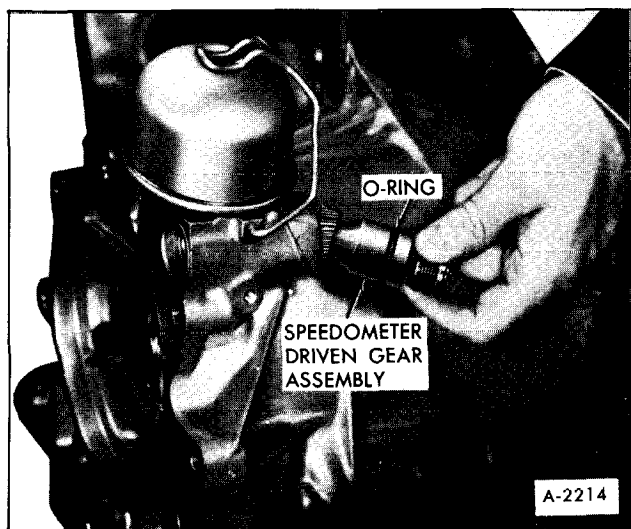

Figure 97—Installing Speedometer Driven Gear

2. Install new square cut O-ring seal on governor assembly and install assembly into transmission case.

3. Position retaining clip on top of governor assembly.

INSPECT SPEEDOMETER DRIVEN GEAR ASSEMBLY

1. Inspect gear for damaged teeth or shaft.

2. Inspect sleeve for scores, damaged threads or cracks.

INSTALL SPEEDOMETER DRIVEN GEAR

1. Install new O-ring seal on speedometer driven gear assembly.

2. Lubricate housing lip with a thin coat of Dex-ron transmission fluid.

3. Install speedometer housing and seal assembly and white nylon driven gear into transmission case, Figure 97.

4. Position retaining clip to transmission and driven gear assembly and secure with one attaching bolt, tightening bolt to 6 ft. lbs.

CONVERTER

INSPECT TORQUE CONVERTER

1. Check converter for leaks as follows:

a. Insert valve, part of Converter Leak Test Fixture, J-21369, in neck of converter and back-off large hex nut.

b. Install leak test fixture band crosswire on converter so that slotted plate fits around valve and under nut. Tighten nut to expand O-ring and secure a good seal.

c. Apply compressed air with a service air hose until approximately 80 to 100 psi. air pressure is obtained.

d. Immerse assembly in water, noting any sign of bubbles that would indicate a leak.

WARNING: ALWAYS RELEASE AIR PRESSURE BEFORE REMOVING VALVE, AS A DEFINITE HAZARD EXISTS SHOULD VALVE BLOW OUT DURING REMOVAL.

e. Thoroughly dry converter.

2. Check converter hub surfaces for signs of scoring or wear.

INSTALL TORQUE CONVERTER

1. Position transmission jack to transmission and install transmission on jack using safety chain.

2. Carefully position converter on turbine shaft, making certain converter is properly aligned. Long screws or eyebolts can be threaded into the weld nuts on the converter and used as handles.

3. Rotate converter until the shafts are piloted and the converter lugs are indexed in the pump gear.

4. If difficulty is experienced in alignment, tap on outer diameter of converter with plastic-headed hammer, while turning converter.

5. Install Converter Holding Clamp, J-21366, on transmission case.

6. Remove two (2) 8" bolts from case to engine mounting face.

INSTALLING FINAL DRIVE (FIGURE 29)

1. Install new gasket, on final drive, after first soaking with transmission fluid.

2. Align final drive to transmission and secure with bolts "B, C, E, F, G" and nut "H", torque to 25 ft.-lbs.

3. Install new O-ring on filler tube assembly and assembly to final drive. Torque bolt "A" to 25 ft.-lbs.

NOTE: Install transmission and final drive in vehicle as described earlier in this section.

TRANSMISSION SPECIFICATIONS

TORQUE CHART

Material Number	Application	Thread Size	Foot Pounds
280M	Transmission to Engine Bolts.....	3/8-16	35
300M	Torque Converter to Flywheel	3/8-16	30
1010	Flywheel Housing Cover	5/16-18	5
300M	Final Drive to Transmission	3/8-16	25
280M	Solenoid to Case Screw	1/4-20	10
Special	Line Pressure Plug.....	1/8 Pipe	13
260M	Vacuum Modulator Retainer.....	5/16-18	18
260M	Valve Body to Case.....	1/4-20	8
300M	Center Support to Case.....	3/8-16	23
286M	Manual Shaft to Inside Lever.....	3/8-24	18
280M	Pump Body to Cover Plate	5/16-18	20
280M	Parking Brake Bracket to Case	5/16-18	18
1010-1020	Oil Pan to Case.....	5/16-18	12
280M	Sprocket Housing	1/4-20	8
260M	Support Housing to Cover Plate	5/16-18	20
260M	Speedometer Driven Gear Retainer	5/16-18	18

SPECIAL TOOLS

J 4646	Snap Ring Pliers
J 4670-01	Forward Clutch Spring Compressor (Use with J-6129 & J-21664).....
J 5907	Pressure Gauge Set (0-300 psi-9' hose)
J 6116-01	Clutch Unit Holding Fixture
J 6129	Direct Clutch Spring Compressor
J 6133-01	Rear Oil Pump Bearing & Speedo Gear Installer
J 21359	Front Pump Oil Seal Installer
J 21362	Forward & Direct Clutch Inner Seal Protector.....
J 21363	Second Clutch Inner Seal Protector.....
J 21369	Converter Leak Test Fixture
J 21370-6	Band to Apply Pin-Body Arm Assembly (Use with J-21370-7 & 8).....
J 21370-7	Band to Apply Pin Gauge (Used with J-21370-6 & 8)
J 21370-8	Band to Apply Pin Selector Plate (Used with J-21370-6 & 7)
J 21409	Forward & Direct Clutch Outer Seal Protector
J 21661	Speedometer Drive Gear Remover Bolts
J 21664	Clutch Compressor Adapter
J 21795-02	Gear Unit Holding Tool
J 22241	Forward Clutch End Play Checking Tool.....
J 22269-01	Control Valve Direct Clutch Accumulator Piston Compressor



SECTION 8 FUEL TANK AND EXHAUST

Contents of this section are listed below:

SUBJECT	PAGE NO.
Evaporation Control System (E.C.S.).....	8-1
Description.....	8-1
Trouble Diagnosis	8-2
Servicing E.C.S.	8-3
Canister(s)	8-3
Canister Filter	8-3
Hoses and Lines.....	8-3
Liquid/Vapor Separator	8-3
Fuel Tanks and Lines	8-4
Description	8-4
Draining Fuel Tanks	8-4
Fuel Tank Replacement	8-4
Fuel Tank Gauge Replacement.....	8-6
Cleaning Fuel Systems.....	8-6
Fuel Tank Purging Procedure.....	8-7
Fuel Tank Leak Test Procedure	8-7
Exhaust System	8-7
Description	8-7
Maintenance.....	8-8

EVAPORATION CONTROL SYSTEM (E.C.S)

DESCRIPTION

In order to limit gasoline vapor discharge into the atmosphere, the following features are incorporated in the fuel system. The E.C.S. system (figure 1) is designed to trap fuel vapors which normally escape from the fuel tank. Vapor arrest is accomplished through the use of a charcoal canister(s) which absorbs the fuel vapors and stores them until they can be removed to be burned in the engine. Removal of vapors from the canister(s) to the engine is accomplished by a calibrated purge orifice in the carburetor. In addition to the carburetor modifications and the canister(s), the fuel tank requires a special

pressure-vacuum gas cap and extra vents to liquid/vapor separator. The liquid/vapor separator prevents liquid gasoline from entering the vapor system to the canister(s). Thus, as vapors are generated in the fuel tank, they flow through the liquid/vapor separator and to the canister(s) where they are stored. From the canister(s) the vapors are routed to the carburetor where they will be burned during normal combustion.

On vehicles sold in California an additional canister is used along with two shields between the fuel tanks and exhaust pipe.

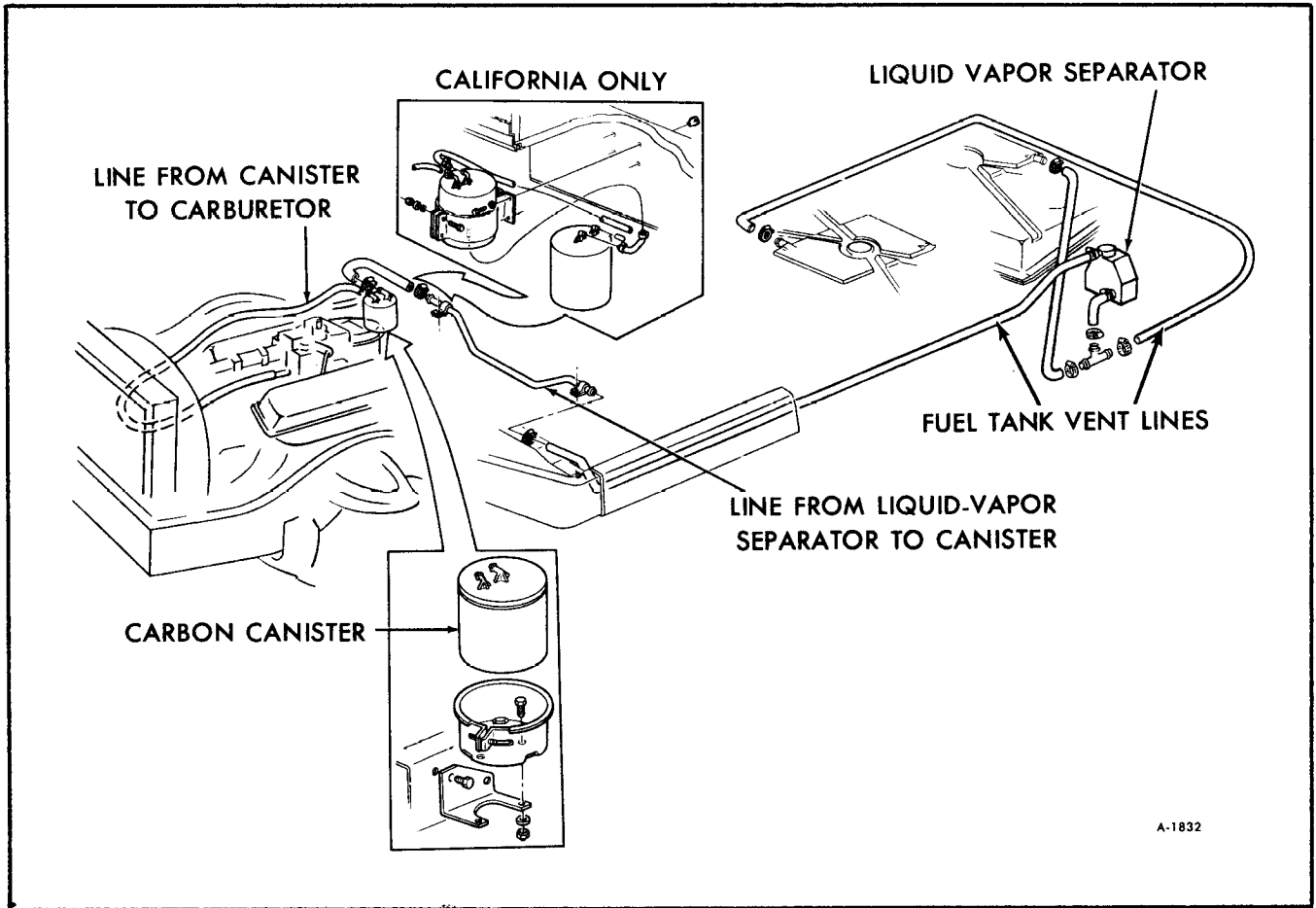

Figure 1—Evaporation Control System

TROUBLE DIAGNOSIS

Condition	Possible Cause	Correction
Fuel odor or loss of fuel rough idle.	Leak in fuel line(s) or hose(s). Purge hose improperly routed. Disconnected purge hose. Plugged canister filter. High volatility fuel.	Replace line or hose. Route hose correctly. Connect hose to proper fitting. Replace filter. Change brand of fuel.
Collapsed tank or pressure in tank.	Plugged or pinched vent line(s). Defective canister. Faulty valve in special tank filler cap.	Remove obstruction or replace line. Replace canister. Install specified replacement cap.

SERVICING E.C.S.

CANISTER(S)

The plastic canister is filled with charcoal which absorbs and stores fuel vapors. When fuel is drawn from the tank during engine operation, a fuel cap tank relief valve opens allowing air to be drawn into the tank. When the engine is running, air is drawn in through the bottom of the canister. This air picks up vapors which are being held in the charcoal and carries them through the carburetor into the engine where they are burned.

REMOVAL

1. Vehicle may be raised if desired.
2. If vehicle is equipped with one canister loosen clamp screw and lift canister up and out.
3. If vehicle is equipped with two canisters remove the lower canister clamp from bracket and slide canister and clamp out. See Figure 1.
4. Disconnect hoses from canister(s).
5. If vehicle is equipped a second canister loosen clamp and lower canister enough to disconnect hoses so it may be removed.

INSTALLATION

1. If the vehicle is equipped with two canisters connect hoses to the upper canister and install. Tighten clamp.
2. Connect hoses to remaining canister and install. Tighten clamp as required.

CANISTER FILTER

REMOVAL

1. Remove canister. Refer to "Canister-Removal" earlier in this section.
2. Filter is located in the bottom of the canister. If vehicle is equipped with two canisters the filter is in the lower canister.
3. Remove filter.

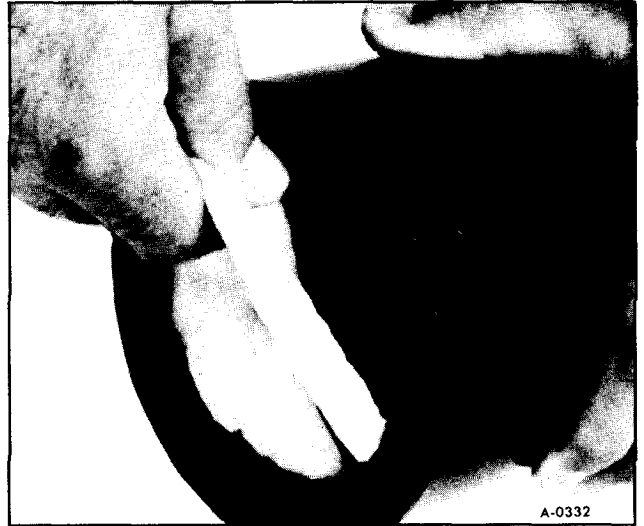

Figure 2—Replacing Canister Filter

INSTALLATION

1. Install filter. See Figure 2.
2. Install canister. Refer to "Canister-Installation" earlier in this section.

HOSES AND LINES

Conventional steel tubing, vapor resistant hose and hose clamps are used to connect the various components of the system. It is extremely important that all pipes and hoses are not kinked, are properly connected, and that all connections are tight. This is necessary to assure a vent through the system for the fuel tank to prevent restriction of vapors to the canister. Thorough visual inspection is and will remain one of the most important checks of the system.

IMPORTANT: Use only hose marked "EVAP" or "GM 6107M" if necessary to replace an E.C.S. hose. Gasoline vapors will deteriorate other types of hoses.

LIQUID/VAPOR SEPARATOR

DESCRIPTION

An external liquid-vapor separator is mounted to left rear wheel opening liner. Its purpose is to stop fuel that has drained out of tanks when the vehicle is parked off level. Once a level position is assumed the fuel in the separator will drain back into the tank.

Any vapors collected in the separator are routed to the canister by a hose. The separator can not be serviced. If damaged it must be replaced.

REMOVAL

1. Clean threads of dirt and remove attaching nuts.
2. Move separator off studs. Mark hoses with

some identification to assure proper matching of hoses and outlets.

3. Disconnect hoses and remove separator.

INSTALLATION

1. Connect hoses to proper ports.
2. Install separator and tighten nuts.

FUEL TANKS AND LINES

DESCRIPTION

The fuel tanks in the models 230 and 260 Motor Homes are dual 25 gallon capacity tanks for a total of 50 gallons. The tanks are located between the frame rails forward of the bogey crossmember.

The filler neck and tubes are constructed of steel tubing with rubber connecting hoses secured by worm-type hose clamps as shown in Figure 3.

The fuel pickup pipe is built integrally with the tank gauge sending unit, located at the top of the tank. A large area, fine mesh screen is located on the bottom of the fuel pickup pipe. This screen is designed to prevent the entrance of dirt or water into the fuel system, and operates with a self-cleaning action.

The tanks consist of an upper and lower half each with a wide flange. The two tank sections are seam welded at the flange to assure leak proof construction. Exceptional stiffness is obtained by the combination of the welded flanges and depressed ribs in both upper and lower tank sections.

DRAINING FUEL TANKS

WARNING: BEFORE ATTEMPTING TO DRAIN FUEL TANK, ALWAYS; REMOVE BATTERY NEGATIVE CABLES, PLACE "NO SMOKING" SIGNS AND A CO2 FIRE EXTINGUISHER NEAR WORK AREA, WEAR SAFETY GLASSES, AND SIPHON OR PUMP FUEL FROM TANK INTO AN EXPLOSIVE PROOF CONTAINER.

The fuel tanks incorporate a drain plug in the left front corner of the tanks. (See figure 4)

To drain the tank remove the drain plug in the tank with the correct size Allen wrench.

Always drain gasoline from complete fuel system including carburetor, fuel pump, all fuel lines and fuel tank if the vehicle is to be stored for any appreciable length of time. This precaution will prevent accumulation of gum formation and resultant poor engine performance.

FUEL TANK REPLACEMENT

WARNING: BEFORE ATTEMPTING FUEL TANK REMOVAL, ALWAYS; REMOVE BATTERY NEGATIVE CABLES, PLACE "NO SMOKING" SIGNS AND A CO2 FIRE EXTINGUISHER NEAR WORK AREA, WEAR SAFETY GLASSES, AND SIPHON OR PUMP FUEL FROM TANK INTO AN EXPLOSIVE PROOF CONTAINER.

1. Drain tanks as previously described.
2. Disconnect fuel filler tubes by loosening worm clamps and slide rubber connectors off ends.
3. Remove 3 bolts from angle at front of tank as shown in Figure 5. If both tanks are to be removed, the forward tank should be completely removed.
4. Slowly lower tanks to allow removal of vent lines and fuel feed lines, label or mark lines to allow reconnection of lines with the same outlet.
5. Using Tool J-24187 as illustrated in Figure 6. Remove fuel tank gauge unit.
6. Reverse steps 1-5.

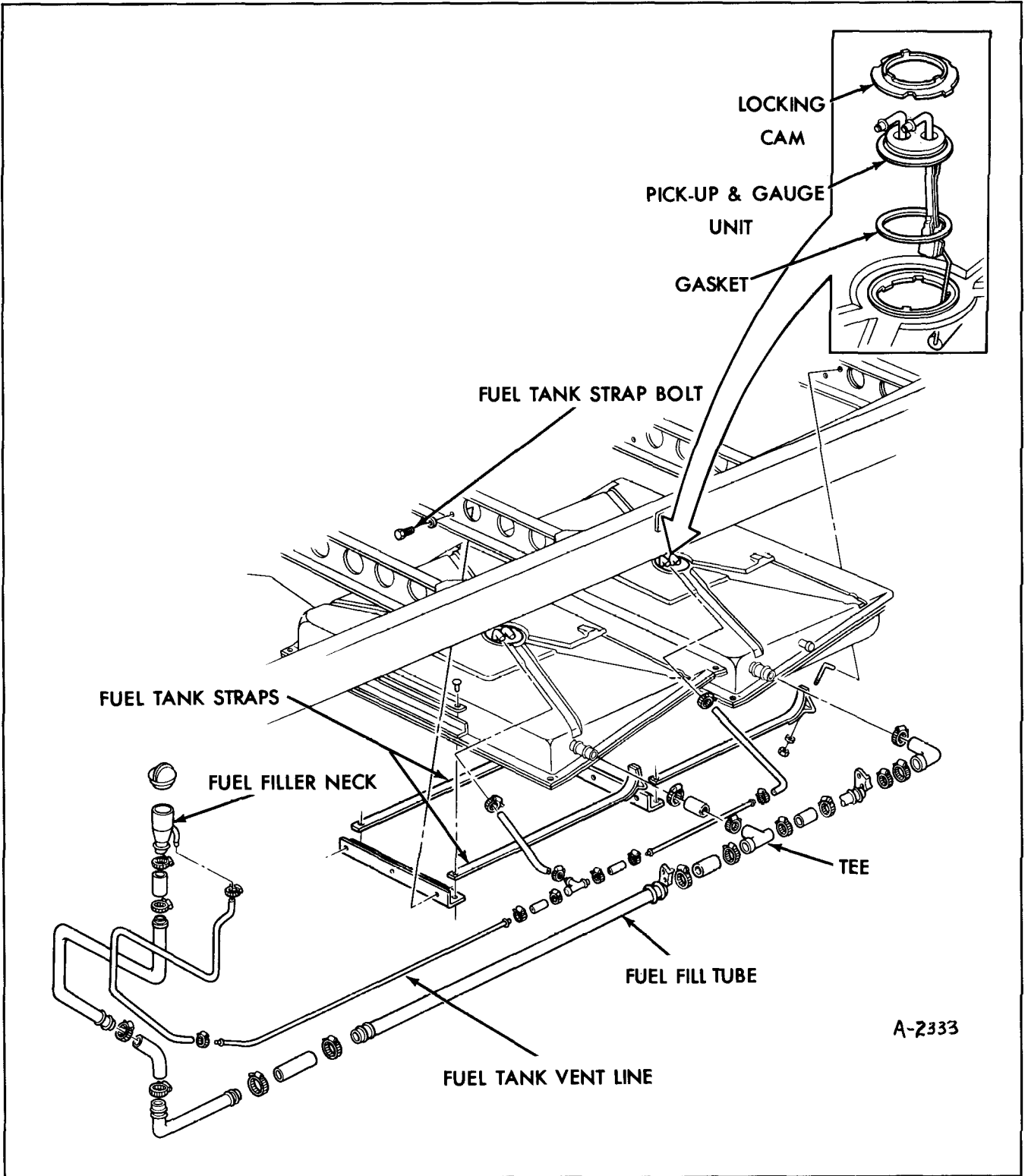

Figure 3—Fuel Tanks and Lines

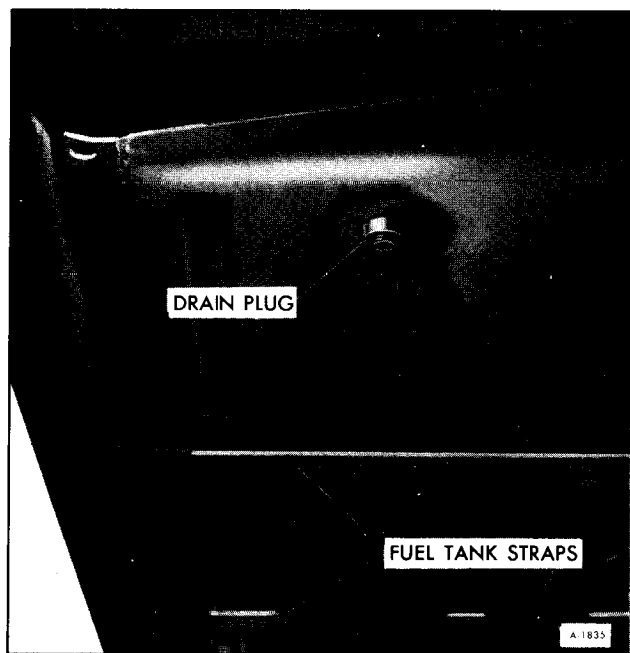

Figure 4—Fuel Tank Drain Plug

FUEL TANK GAUGE REPLACEMENT

1. Follow steps outlined in Fuel Tank Removal.
2. Remove fuel gauge retaining cam, using Tool J-24187 (figure 6).
3. Test gauge unit if required according to the diagnosis check list for fuel tank gauge in Section 12.
4. Reverse steps 1–3, and check operation of gauge.

CLEANING FUEL SYSTEMS

If trouble is due to contaminated fuel or foreign material that has been put into the tank, it can usu-

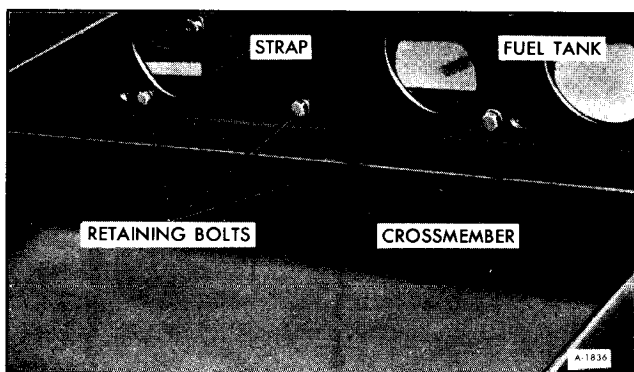

Figure 5—Removing Fuel Tank Strap Bolts

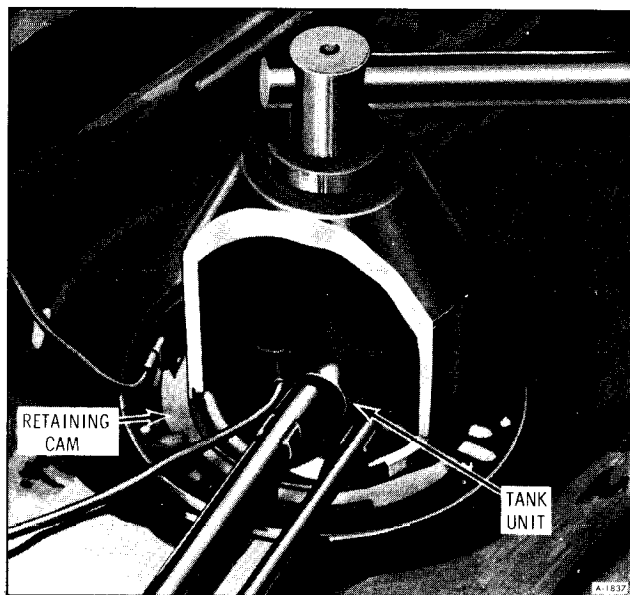

Figure 6—Removing Fuel Tank Gauge Unit

ally be cleaned. If tank is rusted internally, it should be replaced.

1. Disconnect battery ground cables and ignition coil primary wire (+ wire on ignition coil).
2. Drain fuel tank. (See DRAINING FUEL TANK).
3. Remove fuel tank. (See FUEL TANKS – REPLACEMENT).
4. Remove fuel inlet filter at carburetor and inspect for contamination. If filter is plugged, replace. (Leave fuel line disconnected.)
5. Locate tank away from heat, flame or other source of ignition. Remove fuel gauge tank unit and inspect condition of filter. If filter is contaminated, a new filter should be installed upon reassembly.
6. Complete draining of tank by rocking it and allowing fuel to run out of tank unit hole.
7. Purge fuel tank with steam or running hot water for at least five minutes. Pour water out of tank unit hole. (Rock tank to assure complete removal of water.)

IMPORTANT: This procedure will not remove fuel vapor. Do not attempt any repair on tank or filler neck where heat or flame is required.

8. Disconnect inlet fuel line at pump and use air pressure to clean fuel line and fuel return line (if equipped). Apply air pressure in the direction fuel normally flows through line.

9. Use low air pressure to clean pipes on tank unit.

10. Install new filter on fuel tank unit if required. Install fuel tank unit with new gasket into tank and install tank. Connect tank unit wires and all fuel lines except pump to carburetor line. (See REMOVAL OF TANK for proper procedure).

11. Connect a hose to fuel line at carburetor, insert other end of hose into a one gallon fuel can.

12. Connect battery cable. **MAKE SURE IGNITION COIL PRIMARY WIRE (+TERMINAL) IS DISCONNECTED.**

13. Put six gallons of clean fuel in tank and operate starter to pump two quarts of fuel into fuel can. This will purge fuel pump.

14. Remove hose and connect fuel line to carburetor.

15. Connect coil primary wire.

16. Connect battery ground cables.

FUEL TANK PURGING PROCEDURE

1. Remove fuel gauge unit and drain all remaining fuel from tank.

2. Visually inspect interior cavity of tank; if any fuel is evident, drain again.

3. Move tank to flushing area (wash rack).

4. Pour gasoline emulsifying agent and water solution into the tank and agitate mixture for 2 to 3 minutes, wetting all interior surfaces.

NOTE: For correct gasoline emulsifying agent – water mixture, refer to the emulsifying agent

manufacturer's specifications. Use an available emulsifying agent such as "Product -Sol No. 913" or equivalent.

5. Fill tank (with water) to capacity and agitate again.

6. Empty contents.

7. When empty, refill to overflowing with water to completely flush out remaining mixture and then empty tank.

8. If any vapor is present, repeat Steps 4 thru 8. Repeat as necessary until there is no evidence of fuel vapor.

9. Dry tank with compressed air and perform required service work.

FUEL TANK LEAK TEST PROCEDURE

1. Plug all outlets as follows:

a. Use a known good filler cap for filler neck.

b. Install tank unit and plug fuel line.

c. Plug two (2) of the three (3) tank vent tubes using a single short piece of fuel line hose.

d. Install another short piece of fuel line hose on third vent tube.

2. Apply air pressure to tank through open vent tube. Use extreme caution to prevent rupturing the tank. When air can be heard escaping from the filler neck cap (approximately 1 to 1-1/2 lbs. of pressure) pinch the fuel line hose to retain pressure.

3. Test repaired area for leaks with soap solution or by submersion. If leak is noted, make repair and retest.

EXHAUST SYSTEM

DESCRIPTION

The exhaust system on the models 230 and 260 are essentially identical except for a longer length tail

pipe on the 260 model. The exhaust manifolds empty into a muffler for each bank of cylinders which are Y'ed as shown in Figure 7. The tail pipe continues to rear of the vehicle. All exhaust system connections are of the split joint coupled design, secured with U-Bolt clamps.

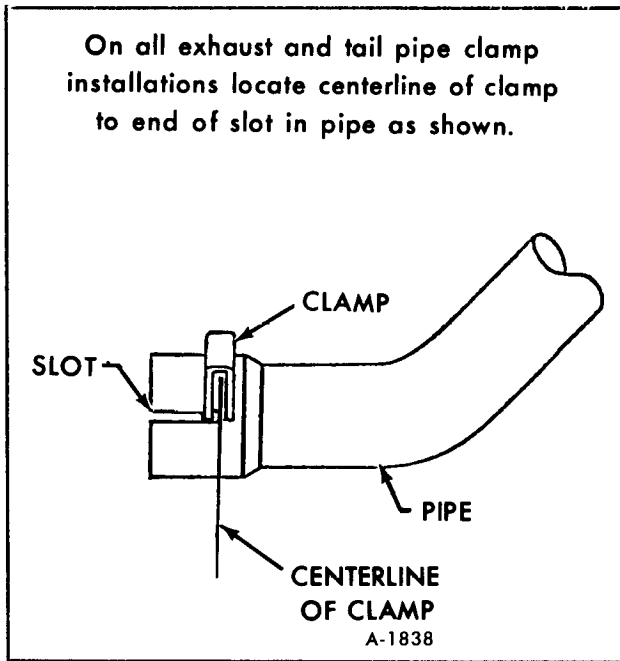

Figure 7—Exhaust System & Clamps

MAINTENANCE

EXHAUST RESTRICTION AND LEAKS

Exhaust system should be inspected periodically for restrictions and leaks. Restrictions such as kinked or crimped pipes result in excessive back pressure which can lead to increased fuel consumption, power loss, and possible damage to engine combustion chamber components. Exhaust leaks are commonly the result of loose clamp assemblies, defective exhaust pipe to manifold packing, or corroded pipes. In addition to objectionable noise, a leaking exhaust system could allow toxic gases to enter vehicle.

Damaged or corroded exhaust system components should be replaced without delay. If it is absolutely necessary to operate vehicle when an exhaust leak exists, use extreme caution and keep vehicle well ventilated.

EXHAUST SYSTEM ALIGNMENT

During installation of a new exhaust pipe, muffler or tail pipe, care should be taken to properly position components in relation to each other.

On all joints except exhaust manifold, apply sealer (GM 9985020) or equivalent, to prevent possible leaks.

Incorrectly assembled parts of exhaust system are frequently the cause of annoying noises and rattles due to improper clearances. Exhaust components must have 3/4" clearance from floor to avoid possible overheating. Therefore, leave all clamp assemblies and muffler strap bolts loose temporarily until the entire system has been inspected to determine if there is adequate clearance between exhaust components and frame members. The weight of the exhaust system should be properly distributed on all supporting brackets and hangers. If the load is not properly balanced, reposition pipes at connecting joints to relieve any concentrated loads. After adjusting hangers, aligning pipes, and repositioning muffler, check entire system for adequate clearance and then tighten all clamps, working from front to rear. (See figure 8) Start engine and inspect all connections for leakage.

NOTE: When installing exhaust pipe to manifold, always use new packing.

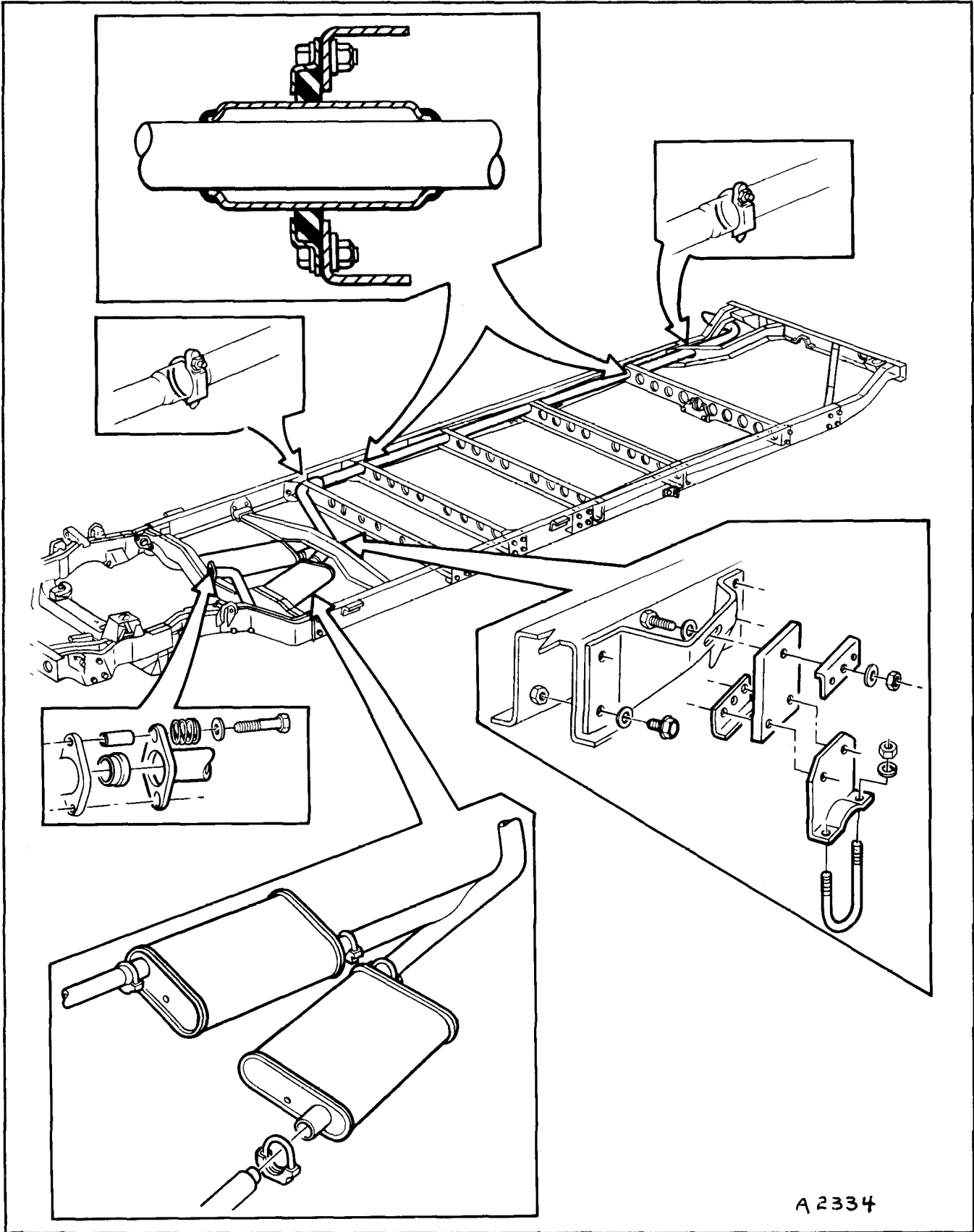

Figure 8-Exhaust Pipe Clamp Installation

SECTION 9

STEERING

Contents of this section are listed below.

SUBJECT	PAGE NO.
Steering Linkage	9- 1
Power Steering Pump	9- 4
Steering Gear	9-19
Steering Column	9-35
Torque Specifications.....	9-63
Special Tools	9-64

CAUTION: *All steering linkage fasteners are important attaching parts in that they could affect the performance of vital components and systems, and/or could result in major repair expense. They must be replaced with one of the same part number or with an equivalent part if replacement becomes necessary. Do not use a replacement part of lesser quality or substitute design. Torque values must be used as specified during reassembly to assure proper retention of these parts.*

STEERING LINKAGE

GENERAL INFORMATION

A parallelogram type steering linkage connects both front wheels to the steering gear through the pitman arm (See figure 1). The right and left tie rods are attached to steering arms at the wheels and to a forged intermediate rod by ball studs.

The left end of the intermediate rod is supported by the relay lever which is driven by the drag link

connected to the pitman arm on the steering gear. The right end of the intermediate rod is supported by an idler arm which pivots on a support attached to the frame. The rear portion of the relay lever and the idler arm are always parallel to each other and move through symmetrical arcs.

The steering linkage is equipped with a linkage shock absorber connected from the intermediate rod to the frame. This is designed to absorb much of the shock to the steering system.

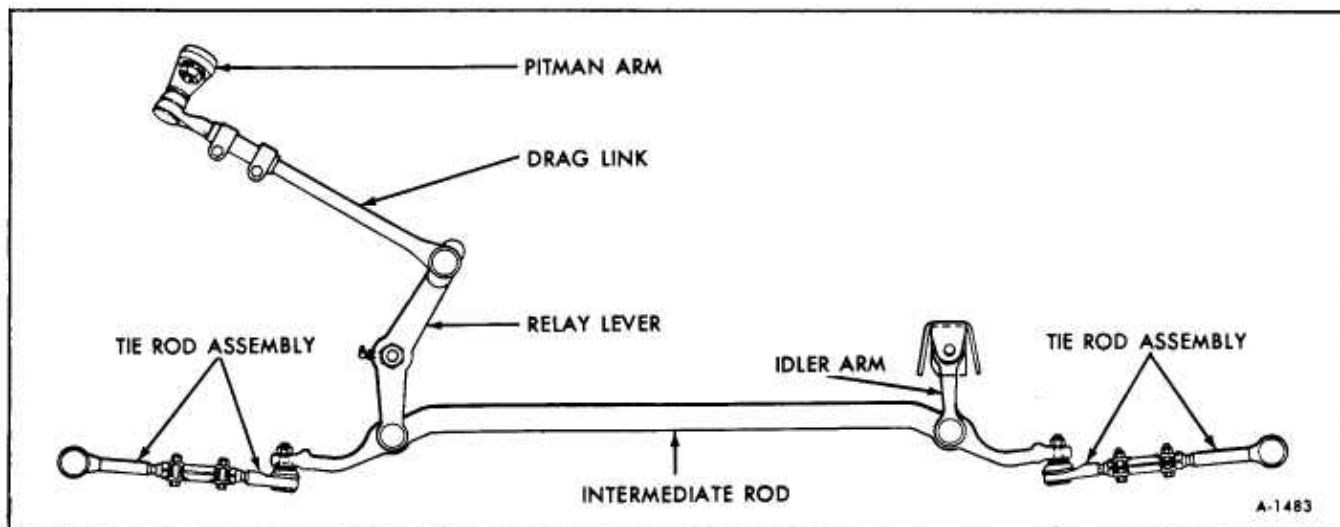

Figure 1-Steering Linkage

STEERING LINKAGE TROUBLE DIAGNOSIS

Condition	Possible Cause	Correction
<p>A. Excessive Play or Looseness in Steering System</p>	<ol style="list-style-type: none"> 1. Front wheel bearings loosely adjusted. 2. Worn couplings or steering shaft U-joints. 3. Worn upper ball joints. 4. Steering wheel loose on shaft, loose pitman arm, tie rods, steering arms or steering linkage ball studs. 5. Steering gear worm bearings loosely adjusted. 6. Excessive pitman shaft to ball nut lash in steering gear. 7. Worn intermediate rod or tie rod sockets. 	<ol style="list-style-type: none"> 1. Adjust bearings or replace with new parts as necessary. 2. Replace. 3. Replace. 4. Tighten to specified torque. 5. Adjust preload to specification. 6. Adjust preload to specification. 7. Replace worn part.
<p>B. Excessive looseness in tie rod or intermediate rod pivots, or excessive vertical lash in idler support.</p>	<ol style="list-style-type: none"> 1. Seal damage and leakage resulting in loss of lubricant, corrosion and excessive wear. 	<ol style="list-style-type: none"> 1. Replace damaged parts as necessary.
<p>C. Hard Steering--Excessive Effort Required at Steering Wheel.</p>	<ol style="list-style-type: none"> 1. Low or uneven tire pressure. 2. Steering linkage or ball joints need lubrication. 3. Tight or frozen intermediate rod, tie rod or idler socket. 4. Steering gear to column misalignment. 5. Steering gear adjusted too tightly. 6. Front wheel alignment incorrect. 	<ol style="list-style-type: none"> 1. Inflate to specified pressures. 2. Lube with specified lubricant. 3. Lube or replace as necessary. 4. Align column. 5. Adjust preload to specification. 6. Check alignment and correct as necessary.
<p>D. Poor Returnability.</p>	<ol style="list-style-type: none"> 1. Steering linkage or ball joints need lubrication. 2. Steering gear adjusted too tightly. 3. Steering gear to column misalignment. 4. Front wheel alignment incorrect. 	<ol style="list-style-type: none"> 1. Lube with specified lubricant. 2. Adjust preload to specifications. 3. Align column. 4. Check alignment and correct as necessary.

tighten nuts just enough to align slot in castellated nut to hole in ball stud and install cotter pin.

5. Lubricate all steering linkage sockets.
6. Lower vehicle.

IDLER ARM

REMOVAL (FIGURE 1)

1. Raise vehicle.
2. Remove cotter pin and castellated nut from idler arm ball stud at intermediate rod.
3. Disconnect idler arm from intermediate rod using a tool such as J-24319 or similar puller.

POWER STEERING PUMP

GENERAL INFORMATION

The housing and internal parts of the pump are inside the reservoir so that the pump parts operate submerged in oil. The reservoir is sealed against the pump housing, leaving the housing face and the shaft hub exposed. The reservoir has a filler neck fitted with a cap. A shaft bushing and seal are pressed into the housing from the front. The drive shaft is inserted through this seal and bushing. A large hole in the rear of the housing contains the functional parts; namely ring, rotor, vanes and plates. A smaller hole contains the control valve assembly and spring.

The thrust plate (figure 2) is located on the inner face of the housing by two dowel pins. This plate has four central blind cavities for undervane oil pressure. The two outer blind cavities direct discharge oil through the two cross-over holes in the pump ring (figure 3), through the pressure plate, and into cavity 1 (figure 4). The two outside indentations in the thrust plate are for intake of the oil from the suction part of the pump.

The pump ring (figure 3) is a plate having the mating surfaces ground flat and parallel. The center hole is a two lobed cam in which the rotor and vanes operate. The ring is placed next to the thrust plate, and located with the same dowel pins.

The pressure plate is fitted against the ring and located with the same two dowel pins. This plate has six through ports. The four central through ports connect from cavity 1 (figure 4) to supply undervane

4. Remove bolt and nut securing idler arm to frame.

INSTALLATION

1. Secure idler arm to frame using bolt and lock nut. Torque nut to 85 to 110 foot pounds.

2. Connect idler arm ball stud to intermediate rod. Install ball stud nut making sure threads are clean, and torque to 40-50 foot-pounds. Then tighten nuts just enough to align slot in castellated nut to hole in ball stud and install cotter pin.

3. Lubricate all steering linkage sockets as described in SECTION 0 of this manual.

4. Lower vehicle.

oil pressure. The two outer ports pass oil under discharge pressure to cavity 1. The two indentations are for oil intake from the suction part of the pump, cavity 7 (figure 4) into the rotor.

The reservoir is for oil storage. It receives and directs the return oil back to the make-up passage of the pump.

The drive shaft is fitted with a pulley and is belt driven from the crankshaft. The rotor is loosely splined to the drive shaft and secured with a retaining ring. It is located centrally within the ring and between the thrust and pressure plates. The ten vanes are mounted in radial slots in the rotor (figure 3).

OPERATION

The mode of operation of the power steering pump is based upon the demand of the power steering gear. The various major modes of operation are: slow cornering, moderate to high speed straight ahead driving, and cornering against the wheel stop. The pump is designed to recognize these conditions as required by the steering gear valve and compensates for them internally.

As the drive shaft turns the rotor, the vane tips follow the inner cam surface of the pump ring, moving outward and inward twice during each revolution. This results in a complete pumping cycle every 180 degrees of rotation (figure 3). Oil is moved in the

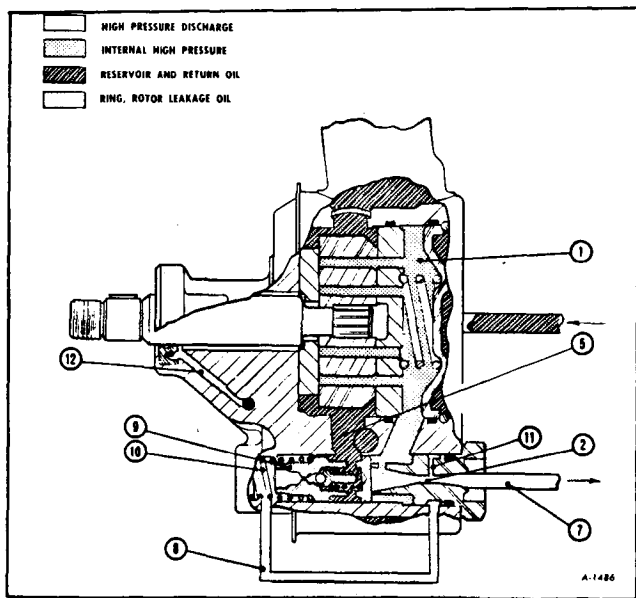

Figure 4-Slow Cornering

(2). This reduces the pressure at the bottom end of the pump control valve (9) because the orifice (11) is connected by passage (8) to (9) resulting in a pressure unbalance on the valve. The flow control valve moves away from the discharge fitting, but due to the force of the flow control spring (10) the valve remains closed to the bypass hole (5). The oil pressure does not build up high enough to cause the pressure relief valve to actuate, because the oil pump through the steering gear is allowed to recirculate through the entire system.

Moderate To High Speed Operation (Figure 5)

When operating at moderate to high speed, it is desirable to limit the temperature rise of the oil. This is done by flow controlling. The control valve in the steering gear is an open center rotary valve. When this valve is in the straight ahead position, oil flows from the pump through the open center valve and back to the pump reservoir without traveling through the power cylinder. When this flow exceeds the predetermined system requirements, oil is bypassed within the pump. This is accomplished by the pressure drop which occurs across the flow control orifice (2). The pressure is reduced at the bottom of the flow control valve (9) because the orifice (11) is connected by (8) to the bottom of valve (9).

The pressure unbalance of the valve is sufficient to overcome the force of the spring (10), allowing the valve to open the bypass hole (5), and diverting oil into the intake chamber (6). Supercharging of the intake chamber occurs under these conditions. Oil at high velocity discharging past the valve into the intake chamber picks up make-up oil at hole (4) from

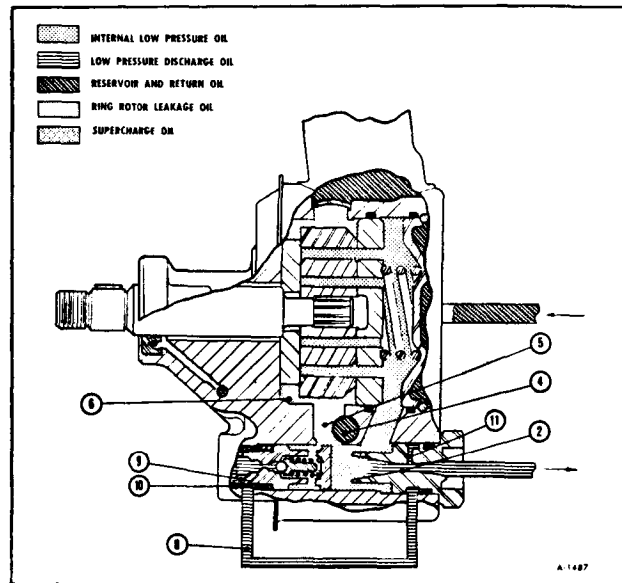

Figure 5-Moderate To High Speed Operation

the reservoir on the jet pump principle. By reduction of velocity, velocity energy is converted into supercharge pressure in cavity (6). During this straight ahead driving condition, the discharge pressure should not exceed 100 psi.

Cornering Against Wheel Stops (Figure 6)

When the steering gear control valve is actuated in either direction to the point of cut-off, the flow of oil from the pump is blocked. This condition occurs when the front wheels meet the wheel stop, or when

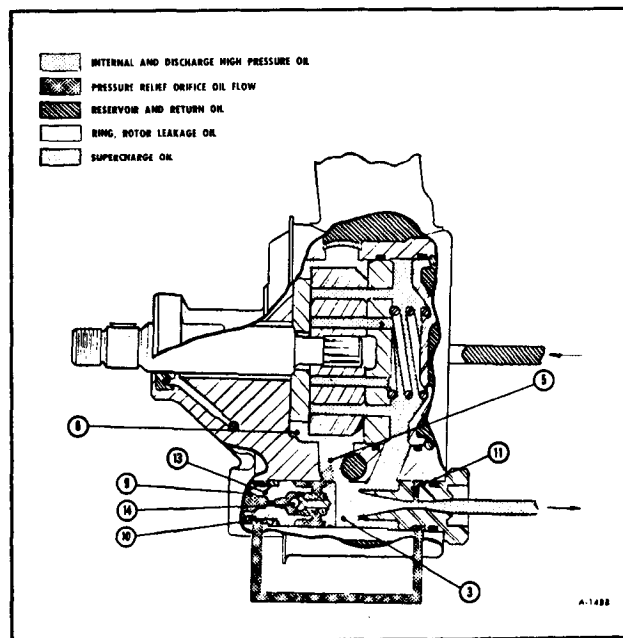

Figure 6-Pressure Relief

STEERING GEAR AND PUMP DIAGNOSIS CHART

Condition	Possible Cause	Correction
Hissing noise in steering gear.	<p>1. There is some noise in all power steering systems. One of the most common is a hissing sound most evident at standstill parking. There is no relationship between this noise and performance of the steering. "Hiss" may be expected when steering wheel is at end of travel or when slowly turning at standstill.</p>	<p>1. Slight "hiss" is normal and in no way affects steering. Do not replace valve unless "hiss" is extremely objectionable. A replacement valve will also exhibit slight noise and is not always a cure for the objection. Investigate clearance around flexible coupling rivets. Be sure steering shaft and gear are aligned so flexible coupling rotates in a flat plane and is not distorted as shaft rotates. Any metal-to-metal contacts through flexible coupling will transmit valve "hiss" into passenger compartment through the steering column.</p>
Rattle or chuckle noise in steering gear.	<p>1. Gear loose on frame.</p> <p>2. Steering linkage looseness.</p> <p>3. Pressure hose touching other parts of car.</p> <p>4. Loose pitman shaft over center adjustment</p> <p>NOTE: A slight rattle may occur on turns because of increased clearance off the "high point." This is normal and clearance must not be reduced below specified limits to eliminate this slight rattle.</p> <p>5. Loose pitman arm.</p>	<p>1. Check gear-to-frame mounting screws. Tighten screws to 70-foot-pounds.</p> <p>2. Check linkage pivot points for wear. Replace if necessary.</p> <p>3. Adjust hose position. Do not bend tubing by hand.</p> <p>4. Adjust to specifications.</p> <p>5. Tighten pitman arm nut to specifications.</p>
Squawk noise in steering gear when turning or recovering from a turn.	<p>1. Damper "O" ring on valve spool cut.</p>	<p>1. Replace damper "O" ring.</p>
Chirp noise in steering pump.	<p>1. Loose belt.</p>	<p>1. Adjust belt tension to specification.</p>
Belt squeal (Particularly noticeable at full wheel travel and stand still parking).	<p>1. Loose belt.</p>	<p>1. Adjust belt tension to specification.</p>

STEERING GEAR AND PUMP DIAGNOSIS CHART (Cont'd.)

Condition	Possible Cause	Correction
Growl noise in steering pump.	1. Excessive back pressure in hoses or steering gear caused by restriction.	1. Locate restriction and correct. Replace part if necessary.
Growl noise in steering pump. (Particularly noticeable at stand still parking).	1. Scored pressure plates, thrust plate or rotor. 2. Extreme wear of cam ring.	1. Replace parts and flush system. 2. Replace parts.
Groan noise in steering pump.	1. Low oil level. 2. Air in the oil. Poor pressure hose connection.	1. Fill reservoir to proper level. 2. Tighten connector to specified torque. Bleed system by operating steering from right to left—full turn.
Rattle or knock noise in steering pump.	1. Loose pump pulley nut.	1. Tighten nut to specified torque.
Rattle noise in steering pump.	1. Vanes not installed properly. 2. Vanes sticking in rotor slots.	1. Install properly. 2. Free up by removing burrs, varnish or dirt.
Swish noise in steering pump.	1. Defective flow control valve.	1. Replace part.
Whine noise in steering pump.	1. Pump shaft bearing scored.	1. Replace housing and shaft. Flush system.
Poor return of steering wheel to center.	1. Lack of lubrication in linkage and ball joints. 2. Lower coupling flange rubbing against steering gear adjuster plug. 3. Steering gear to column misalignment. 4. Tires not properly inflated. 5. Improper front wheel alignment. 6. Steering linkage binding.	1. Lube linkage and ball joints. 2. Loosen pinch bolt and assemble properly. 3. Align steering column. 4. Inflate to specified pressure. 5. Check and adjust as necessary. With front wheels still on alignment pads of front end machine, disconnect pitman arm of linkage from pitman shaft of gear. Turn front wheels by hand. If wheels will not turn or turn with considerable effort, determine if linkage or ball joints are binding. 6. Replace pivots.

STEERING GEAR AND PUMP DIAGNOSIS CHART (Cont'd.)

Condition	Possible Cause	Correction
	<p>7. Ball joints binding. (Turn steering wheel and listen for internal rubbing in column—check causes listed and correct as directed).</p> <p>8. Steering wheel rubbing against directional signal housing.</p> <p>9. Tight or frozen steering shaft bearings.</p> <p>10. Rubber spacer binding.</p> <p>11. Sticky or plugged valve spool.</p> <p>12. Steering gear adjustments over specifications.</p>	<p>7. Replace ball joints.</p> <p>8. Adjust steering jacket.</p> <p>9. Replace bearings.</p> <p>10. Make certain spacer is properly seated. Lubricate inside diameter with silicone.</p> <p>11. Remove and clean or replace valve.</p> <p>12. Check adjustment with gear out of vehicle. Adjust as required.</p>
<p>Vehicle leads to one side or the other. (Keep in mind road condition and wind. Test vehicle on flat road going in both directions).</p>	<p>2. Unbalanced steering gear valve. NOTE: If this is cause, steering effort will be very light in direction of lead and heavy in opposite direction.</p>	<p>2. Replace valve.</p>
<p>Momentary increase in effort when turning wheel fast to right or left.</p>	<p>1. Low oil level in pump.</p> <p>2. Pump belt slipping.</p> <p>3. High internal leakage.</p>	<p>1. Add power steering fluid as required.</p> <p>2. Tighten or replace belt.</p> <p>3. Check pump pressure. (See pump pressure test).</p>
<p>Steering wheel surges or jerks when turning with engine running especially during parking.</p>	<p>1. Low oil level.</p> <p>2. Loose pump belt.</p> <p>3. Steering linkage hitting engine oil pan at full turn.</p> <p>4. Insufficient pump pressure.</p> <p>5. Sticky flow control valve.</p>	<p>1. Fill as required.</p> <p>2. Adjust tension to specification.</p> <p>3. Correct clearance.</p> <p>4. Check pump pressure. (See pump pressure test). Replace relief valve if defective.</p> <p>5. Inspect for varnish or damage, replace if necessary.</p>

STEERING GEAR AND PUMP DIAGNOSIS CHART (Cont'd.)

Condition	Possible Cause	Correction
Excessive wheel kick-back or loose steering.	<ol style="list-style-type: none"> 1. Air in system. 2. Steering gear loose on frame. 3. Steering gear flexible coupling loose on shaft or rubber disc mounting screws loose. 4. Steering linkage joints worn enough to be loose. 5. Worn poppet valve (Gear). 6. Loose thrust bearing preload adjustment. (Gear). 7. Excessive "over-center" lash. 	<ol style="list-style-type: none"> 1. Add oil to pump reservoir and bleed by operating steering. Check hose connectors for proper torque and adjust as required. 2. Tighten attaching screws to specified torque. 3. Tighten flange pinch bolts to 30 foot-pounds, if serrations are not damaged. Tighten upper flange to coupling nuts to specified torque. 4. Replace loose pivots. 5. Replace poppet valve. 6. Adjust to specification with gear out of vehicle. 7. Adjust to specification with gear out of vehicle.
<p>Hard steering or lack of assist.</p> <p>NOTE: If checks 1 through 5 do not reveal cause of hard steering, follow the procedure below to determine fault.</p>	<ol style="list-style-type: none"> 1. Loose pump belt. 2. Low oil level in reservoir. <p>NOTE: Low oil level will also result in excessive pump noise.</p> <ol style="list-style-type: none"> 3. Steering gear to column misalignment. 4. Lower coupling flange rubbing against steering gear adjuster plug. 5. Tires not properly inflated. <p>Further possible causes could be:</p> <ol style="list-style-type: none"> 6. Sticky flow control valve. 7. Insufficient pump pressure output. 8. Excessive internal pump leakage. 9. Excessive internal gear leakage. 	<ol style="list-style-type: none"> 1. Adjust belt tension to specification. 2. Fill to proper level. If excessively low, check all lines and joints for evidence of external leakage. Tighten loose connectors to 30-ft-lbs. 3. Align steering column. 4. Loosen pinch bolt and assemble properly. 5. Inflate to recommended pressure. <p>In order to diagnose conditions such as listed in 6, 7, 8, 9 a test of the entire power steering system is required.</p>

STEERING GEAR AND PUMP DIAGNOSIS CHART (Cont'd.)**POWER STEERING SYSTEM TEST PROCEDURE**

1. Disconnect pressure hose at union of pump, use a small container to catch any fluid which might leak.
2. Connect a spare pressure hose to pump union.
3. Using pressure gage J 5176-1, adapter fitting J 22326, connect gage to both hoses.
4. Open hand valve on gage.
5. Start engine, allow system to reach operating temperatures and check fluid level adding any fluid if required. When engine is at normal operating temperature, the initial pressure read on the gage (valve open) should be in the 80-125 psi range. Should this pressure be in excess of 200 psi—check the hoses for restrictions and the poppet valve for proper assembly.
6. Close gate valve fully 3 times. Record the highest pressures attained each time. (Note: do not leave valve fully closed for more than 5 seconds as the pump could be damaged internally).
 - (a) If the pressures recorded are within 1250-1350 psi and the range of readings are within 50 psi, the pump is functioning within specs.
 - (b) If the pressures recorded are high, but do not repeat within 50 psi, the flow controlling valve is sticking. Remove the valve, clean it and remove any burrs using crocus cloth or fine hone. If the system contains some dirt, flush it. If it is exceptionally dirty, both the pump and the gear must be completely disassembled, cleaned and reassembled before further usage.
 - (c) If the pressures recorded are constant, but more than 100 psi, below the low listed spec., replace the flow control valve and recheck. If the pressures are still low, replace the rotating group.
7. If the pump checks to specs., leave the valve open and turn (or have turned) the steering wheel into both corners. Record the highest pressures and compare with the maximum pump pressure recorded. If this pressure cannot be built in either (or one) side of the gear, the gear is leaking internally and must be disassembled and repaired.
8. Shut off engine, remove testing gage, spare hose, reconnect pressure hose, check fluid level or make needed repairs.

STEERING GEAR AND PUMP DIAGNOSIS CHART (Cont'd.)

Condition	Possible Cause	Correction
Foaming milky power steering fluid, low fluid level and possible low pressure.	1. Air in the fluid, and loss of fluid due to internal pump leakage causing overflow.	1. Check for leak and correct. Bleed system. Extremely cold temperatures will cause system aeration should the oil level be low. If oil level is correct and pump still foams, remove pump from vehicle and separate reservoir from housing. Check welsh plug and housing for cracks. If plug is loose or housing is cracked, replace housing.
Low pressure due to steering pump.	1. Flow control valve stuck or inoperative. 2. Pressure plate not flat against cam ring. 3. Extreme wear of cam ring. 4. Scored pressure plate, thrust plate or rotor. 5. Vanes not installed properly. 6. Vanes sticking in rotor slots. 7. Cracked or broken thrust or pressure plate.	1. Remove burrs or dirt or replace. 2. Correct. 3. Replace parts. Flush system. 4. Replace parts. (If rotor, replace with rotating group kit). Flush system. 5. Install properly. 6. Free-up by removing burrs, varnish or dirt. 7. Replace part.
Low pressure due to steering gear.	1. Pressure loss in cylinder due to worn piston ring or badly worn housing bore. 2. Leakage at valve rings, valve body to worm seal.	1. Remove gear from vehicle for disassembly and inspection of ring and housing bore. 2. Remove gear from vehicle for disassembly and replace seals.

REMOVAL OF PUMP (FIGURE 7)

1. Loosen power steering and Delcotron belts.

2. Disconnect pressure line and return hose from pump. (Install caps at both pump fittings to prevent drainage of oil from pump.)

3. Remove power steering pump mounting bolts and nuts, and upper left venturi bracket. (See figure 7).

4. Remove power steering pump with adjusting link attached.

5. Remove adjusting link from pump.

6. Remove pulley by removing pulley nut and

then using a tool such as J-21239-1 or equivalent remove pulley.

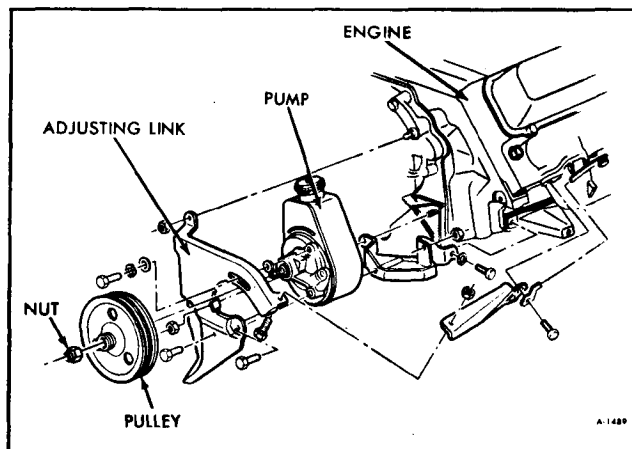

Figure 7—Pump Installation

PUMP DISASSEMBLY

Before disassembly of pump, remove reservoir filler cap and drain oil from reservoir by inverting the pump so oil may drain out the filler hole.

After oil is drained from reservoir, cap should be replaced and the entire pump assembly washed in a non-toxic solvent to remove all dirt and prevent any foreign matter from contaminating pump components.

1. Clamp front hub of pump in vise so that the extending portion of shaft is directed downward, being careful not to clamp vise too tight as this may distort the bearing (figure 8).

2. Using proper sized wrenches, remove union and "O" ring assembly and both mounting studs from back of reservoir. Discard all seals and "O" rings. (figure 8).

3. Reservoir may then be removed from housing by rocking it slightly back and forth to unseat the "O" ring. Remove "O" ring and discard.

4. Remove both mounting stud and union seals from counterbored spaces between reservoir and housing. Discard these seals also. (figure 9).

5. Remove the end plate retaining ring by inserting a small punch in the 1/8 inch diameter hole in the housing side opposite the flow control valve hole. Compress the retaining ring with the punch and remove by inserting a screwdriver under the ring and twisting the screwdriver. (figure 10).



Figure 8—Studs & Union Being Removed

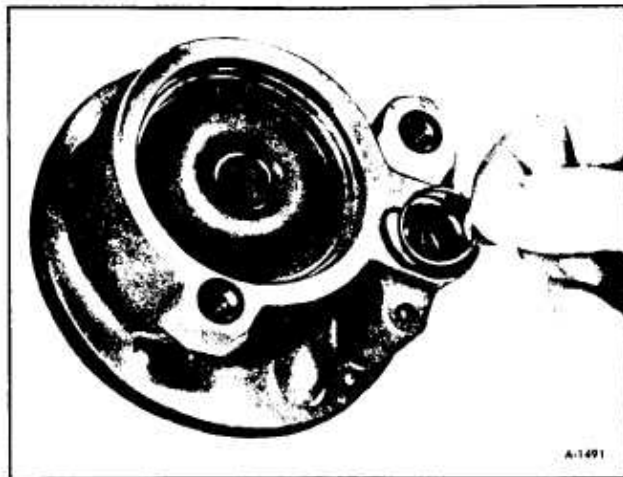

Figure 9—Removal of Stud & Union Seals

6. Remove end plate and end plate "O" ring. End plate is spring loaded and will generally sit above the housing level for ease of removal. If sticking should occur, a slight rocking action of the end plate should be used to free it. (figure 11).

7. Remove pump from vise and invert. Flow control valve and valve spring will fall free. (figure 12).

8. Remove key from shaft end where pulley was mounted.

9. With end cover "O" ring and shaft key removed, tap very lightly on end of shaft, only until pressure plate falls free. (figure 13).

10. Remove pressure plate, shaft, pump ring, vanes and rotor. (figure 14).

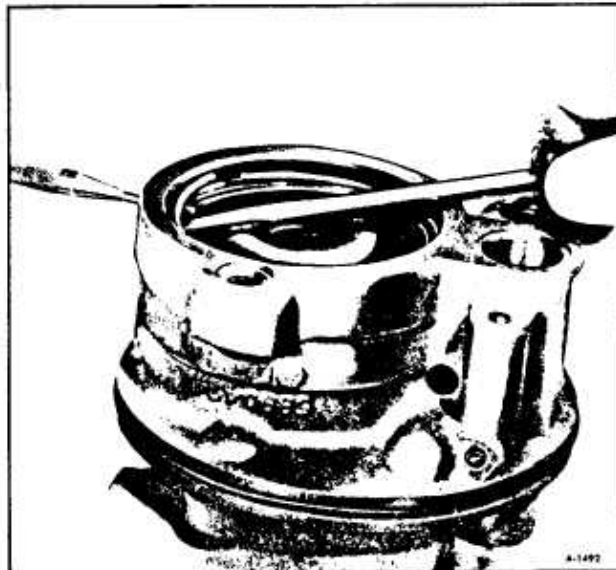

Figure 10—Removal of End Plate Retaining Ring



Figure 11-Removal of End Plate

11. Remove shaft retaining ring and discard. (Some models do not have retaining rings).

12. Remove rotor and thrust plate from shaft and both dowel pins from housing. (figure 15).

13. Pry shaft seal out of housing, being careful not to damage the housing bore; discard the shaft seal.

CLEANING AND INSPECTION

Carefully clean all pump parts in non-toxic cleaning solvent. Replace any damaged or worn parts.

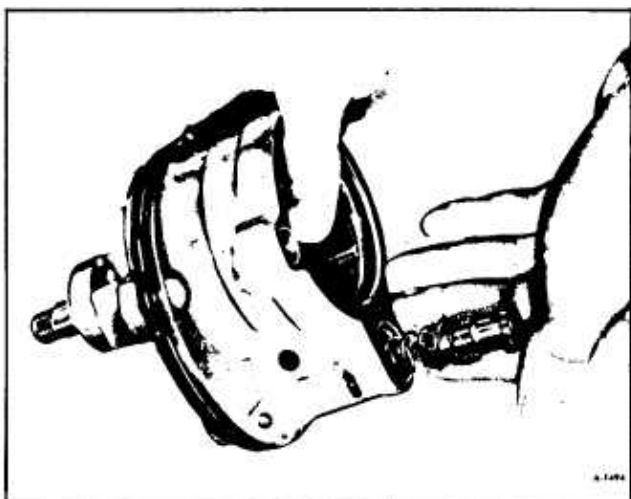

Figure 12-Removal of Relief Valve



Figure 13-Tapping Shaft to Unseat Pressure Plate

1. Inspect flow control valve assembly for score marks, wear, burrs, or other damage.

2. Inspect castings for cracks or other visual evidences of damage. Check machined surfaces, especially mating surfaces on "O" ring seats, for scratches or burrs that might permit leaks. Examine

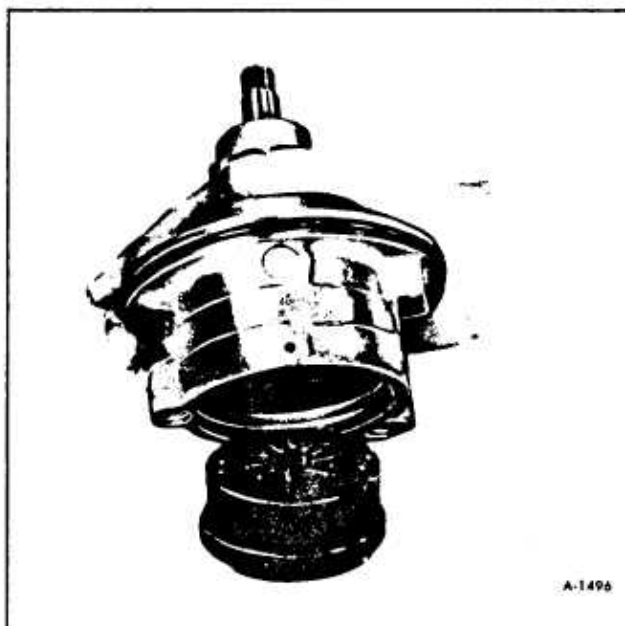

Figure 14-Removal of Shaft, Pressure Plate, Pump Ring, Vanes and Rotor

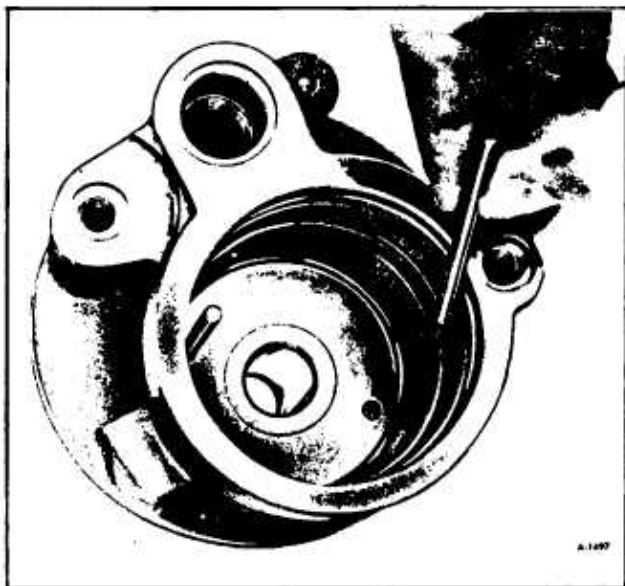

Figure 15—Removing Dowel Pins From Housing

the V-shaped notches at edges of discharge ports on pressure plate. These notches must be clean and undamaged if pump noise is to be avoided, as they cushion the hydraulic shock when each vane passes the port.

3. Inspect pump ring end surfaces for score marks.

NOTE: Pump ring is treated which leaves a dull gray-black finish on wear surface. Wavy grain appearance inside pump ring is normal.

4. Inspect pump shaft for score marks, excessive wear, or damage—particularly at splines, keyway, and at bearing and seal surfaces. Separate and inspect rotor and vanes for wear and general condition.

5. Inspect shaft bushing in pump housing, and replace pump housing if bushing is scored or excessively worn.

6. If any internal parts are found to be worn or damaged, flush steering gear or disassemble gear and clean internal parts.

ASSEMBLY OF PUMP

1. Install new pump shaft seal using seal protector J-22616 and seal installer J-7728 or a 1 inch socket with an arbor press or hammer. (figure 16). Do not use any more force than necessary to seat the seal.

2. Lubricate new pressure plate "O" ring with

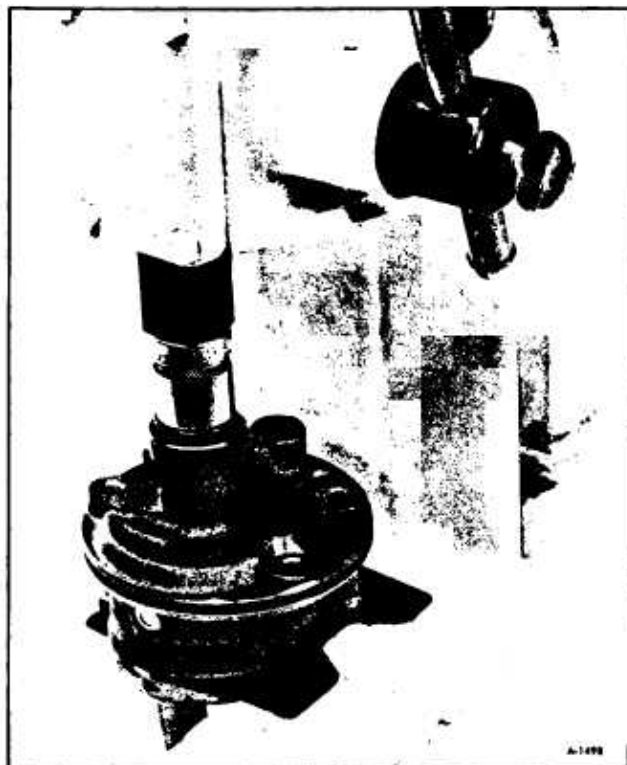

Figure 16—Installing Shaft Seal

Power Steering Fluid, and install in third groove from rear of housing.

3. Clamp end hub of housing in vise in same position as before and insert both dowel pins. (figure 15). Do not over tighten the vise—damage to the bearing could occur.

4. Insert shaft through thrust plate and rotor, and install new snap ring on shaft. Open the snap ring just enough to slide over the end of shaft. (Rotor must have counter sunk side toward thrust plate.) (figure 17).

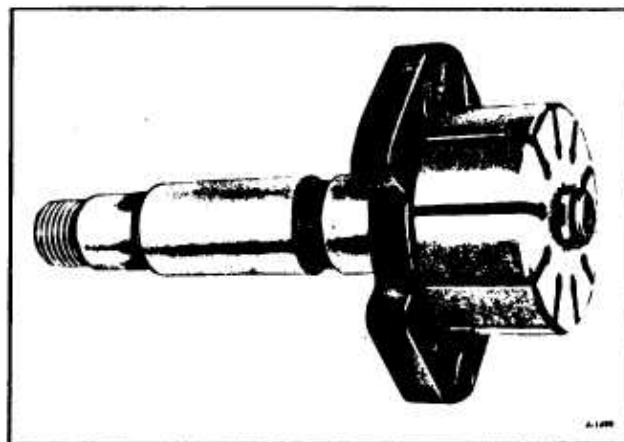

Figure 17—Shaft With Thrust Plate and Rotor



Figure 18—Pump Ring Showing Arrow

5. Insert shaft in housing, making sure thrust plate slides properly on dowel pins.

6. Install pump ring on dowel pins with the arrow toward rear of housing (figure 18).

7. Install all ten vanes in rotor slots with rounded edge of vanes outward (figure 3 and 19). Vanes should slide freely.

8. Lubricate pressure plate with Power Steering Fluid so as not to damage pressure plate "O" ring.



Figure 19—Replacement of Pump Vanes



Figure 20—Installing Pressure Plate

9. Install pressure plate on dowel pins with circular depression for spring toward rear of housing. Pressure plate must be pressed about 1/16 inch over the "O" ring to seat (figure 20).

10. Lubricate new end plate "O" ring with Power Steering Fluid and install in second groove from rear of housing.

11. Install end plate spring in groove provided in pressure plate (figure 11).

12. Lubricate end plate with Power Steering Fluid so as not to damage "O" ring and press into housing with an arbor press (figure 21). Depress only far enough to enable retaining ring to seat properly in groove.

13. Install end plate retaining ring and release arbor press.

14. Place flow control valve spring in hole first and then insert flow control valve with screened end toward front of housing.

15. Install new stud seals and union seals in counter sunk holes, and lubricate with Power Steering Fluid and install new reservoir "O" ring on housing (figure 9).

16. Lubricate inside edge of reservoir with Power Steering Fluid and install on housing being careful to align holes at the same time.

17. Insert both stud bolts and tighten with proper sized wrenches (25-40 ft. lb.) (figure 8).

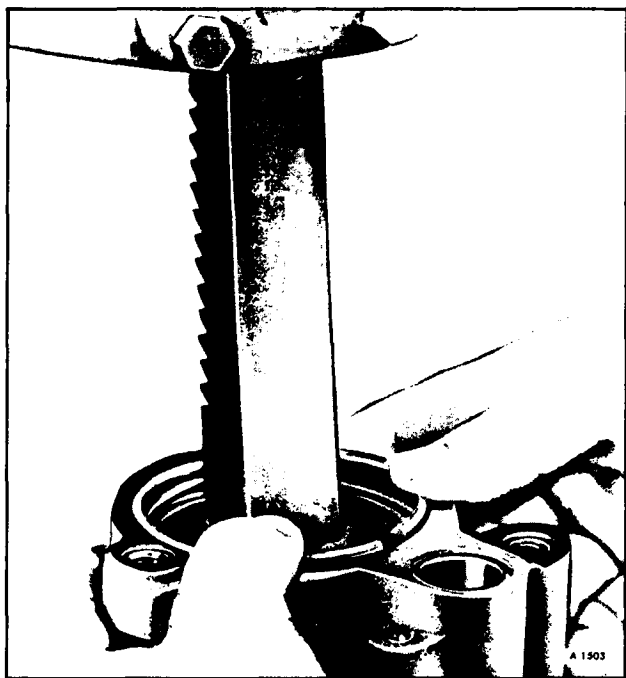

Figure 21—Installation of End Plate Retaining Spring

18. Install new “O” ring on union and lubricate with Power Steering Fluid. Make sure “O” ring is in the groove next to the head hex. Insert union in flow control valve hole in back of reservoir and tighten with proper size wrenches (25-40 ft. lbs.) (figure 8).

19. Install key in shaft end. Support the shaft on the opposite side of the key way and tap the key lightly into place with plastic hammer.

INSTALLATION OF PUMP (FIGURE 7)

1. Install adjusting link on pump.

2. Slide pulley on shaft. Do not hammer pulley on, as this will damage internal pump parts. Install pulley nut finger tight against pulley. (Always use a new nut).

3. Install pump assembly on engine and secure with bolts and nuts and install venturi bracket.

4. Connect and tighten hose fittings to 30-40 foot-pounds.

5. Fill reservoir with fluid.

Bleed pump by turning pulley backward (counterclockwise as viewed from front) until air bubbles cease to appear.

6. Install pump belts over pulley.

7. Move pump until belts are tight, then tighten adjusting screws. Do not pry on reservoir or pull on filler neck.

8. Torque pulley nut to 50-70 foot pounds.

9. Adjust belts. (Refer to ADJUSTMENTS).

10. Bleed system. (Refer to FLUID LEVEL under ADJUSTMENTS).

ADJUSTMENTS

FLUID LEVEL

1. Run engine until Power Steering Fluid reaches normal operating temperature, approximately 170°F., then shut engine off. Remove reservoir filler cap and check oil level on dipstick.

2. If oil level is low, add Power Steering Fluid to proper level on dipstick and replace filler cap.

NOTE: When adding or making a complete fluid change, always use special power steering fluid available from servicing parts warehouses.

3. When checking fluid level after the steering system has been serviced, air must be bled from the system. Proceed as follows:

a. With wheels turned all the way to the left, add power steering fluid to “Cold” mark on dipstick.

b. Start engine, and running at fast idle, recheck fluid level. Add fluid if necessary to “Cold” mark on dipstick.

c. Bleed system by turning wheels from side to side without hitting stops. Maintain fluid level just above internal pump casting. Fluid with air in it will have a light tan or red appearance. This air must be eliminated from fluid before normal steering action can be obtained.

d. Return wheels to center position and continue to run engine for two or three minutes then shut engine off.

e. Road test car to make sure steering functions normally and is free from noise.

f. Recheck fluid level as described in steps 1 and 2, making sure fluid level is at “Hot” mark on dipstick after the system has stabilized at its normal operating temperature.

BELT ADJUSTMENT

When adjusting a power steering pump belt, never pry against the pump reservoir or pull against the filler neck. To increase belt tension move the pump outward by prying against the bracket pry lugs or against the pump housing casting extension directly behind the pump drive pulley.

A belt that has been previously tensioned is considered to be a used belt and should be tightened to 70 to 80 pounds. A belt that has never been tensioned is considered to be a new belt and should be tightened to 110 to 140 pounds.

Place belt tension gauge J-23600 or equivalent midway between the pulleys on drive belt being checked. If the belt tension is incorrect proceed as follows:

ADJUSTING BELT TENSION

1. When power steering pump is driven by a single belt.

a. Loosen the pump attaching bolts and adjust the belt to correct tension by moving the pump outward, away from the engine.

b. Snug all pump mounting bolts and remove pry bar.

c. Tighten all pump mounting bolts to specified torque.

d. Check belt tension and remove the belt tension gage.

2. When the power steering pump pulley is driven by one primary belt and is used as an idler for a second belt driving some other auxiliary:

a. Follow same checking and adjusting procedure for the primary power steering pump drive belt as for 1 above.

b. Recheck and adjust as necessary the pump belt tension after adjusting tension on belt driving the auxiliary.

STEERING GEAR

GENERAL INFORMATION

The integral power steering gear has an open center, rotary type, three-way control valve, which directs oil to either side of the rack piston. The rack piston converts hydraulic power into mechanical output. The steering gear is mounted on the left frame rail by four mounting bolts. The steering shaft is joined to the steering gear through a flexible coupling, which reduces the transmission of hydraulic noise to the steering wheel.

A constant displacement pump provides hydraulic pressure for the steering system. The pump is a pulley driven vane type having an oil reservoir, which is part of the pump. It is attached to the front of the engine by a bracket, and is belt driven from an engine crank shaft pulley.

OPERATION

NEUTRAL (STRAIGHT AHEAD POSITION)

When turning effort is not being applied at the steering wheel, the slots in the spool valve are positioned so that oil entering the valve body from the housing pressure port passes through the slots in the

spool valve to the oil return port in the housing. The chambers at both ends of the rack-piston and around the pitman shaft are always full of oil, which acts as a cushion to absorb road shock so that they are not transferred to the driver. In addition, this oil lubricates all the internal components of the gear.

RIGHT TURN

When the steering wheel is turned to the right, the worm resists being turned because of the resistance offered by the front wheels. The valve body also resists turning because it is pinned to the worm. Driver force exerted at the steering wheel turns the stub shaft and spool valve a slight amount in relation to the valve body because of the twisting action of the torsion bar. This slight amount of turning of the spool valve is sufficient to position the slots in the valve body and spool valve for power assist.

The right turn slots in the spool valve are closed off from the return (wide) slots in the valve body and opened more to the pressure (narrow) slots in the valve body. The left turn slots in the spool valve are closed off from the pressure slots in the valve body and opened more to the return slots in the valve body.

Pressure immediately begins to build up against the lower end of the rack-piston, forcing it upward to apply turning effort to the pitman shaft. The oil in the chamber at the upper end of the rack-piston is then forced out through the valve body and spool valve through the oil return port to the pump reservoir.

The instant the driver stops applying turning effort to the steering wheel, the spool valve is forced back into its neutral position by the torsion bar. Oil pressure on the lower end of the rack-piston then decreases so that pressure is again equal on both sides of the rack-piston, and the front wheels return to the straight ahead position, when the vehicle is moving.

Under normal driving conditions, oil pressure does not exceed 200 psi except when turning corners where it does not ordinarily exceed 450 psi. Oil pressure, when parking, ranges from 900 to 1,300 psi depending upon road conditions and weight of the vehicle. The steering effort during normal driving, ranges from 1 to 2 lbs. and during parking from 2 to 3-1/2 lbs. again depending upon road conditions.

A check valve located under the high pressure connector seat hydraulically dampens the shock transmitted to the steering gear when driving on washboard roads.

LEFT TURN

When the steering wheel is turned to the left, the relationship between the spool valve slots and valve body slots is again changed through twisting of the torsion bar. Pressure immediately builds up against the upper end of the rack-piston, forcing it downward to apply turning effort to the pitman shaft. The oil in the chamber at the lower end of the rack-piston is forced out through the valve body and spool valve to the pump reservoir.

TROUBLE DIAGNOSIS

For complete power steering trouble diagnosis see TROUBLE DIAGNOSIS under POWER STEERING PUMP earlier in this section.

STEERING GEAR REMOVAL

1. Disconnect the power steering hoses from the steering gear and cap the hose fittings.

2. Remove the pitman arm shaft nut. Mark the relation of the pitman arm to the pitman shaft. Disconnect the pitman arm from the pitman shaft using tool number J-24319 or similar puller.

3. Loosen steering shaft yoke cinch bolt.

4. Remove the four bolts attaching the gear to the frame side rail, permit the steering shaft yoke to slide free of the steering gear stub shaft and remove the gear.

STEERING GEAR OVERHAUL

Disassembly of the major components within the gear must be performed on a clean work bench. The work area, tools, and parts must be kept clean at all times. Refer to Figures 22 and 23 for parts nomenclature and location.

STEERING GEAR DISASSEMBLY

1. Rotate end cover retainer ring so that one end of the ring is over the hole in the side of the housing. Force the end of the ring from its groove and remove ring (figure 24).

2. Turn the coupling flange counter-clockwise until the rack-piston just forces end cover out of housing. Remove cover and discard "O" ring.

CAUTION: Do not turn stub shaft any further than absolutely necessary to remove the end plug, or balls from rack-piston and worm circuit may escape and lay loose inside the rack-piston chamber.

3. Remove the rack-piston end plug as shown in Figure 25.

NOTE: To aid in loosening the aluminum end plug (female square drive) strike sharply using 1" diameter brass drift or larger and hammer.

4. Remove the pitman shaft and side cover as follows:

a. Loosen the over-center adjusting screw locknut and remove the 4 side cover attaching bolts.

b. Rotate the side cover until the rack-piston and pitman shaft teeth are visible, then turn the coupling flange until the pitman shaft teeth are centered in the housing opening. Tap the pitman shaft with a soft hammer and remove the pitman shaft and side cover from the housing. Remove the side cover "O"

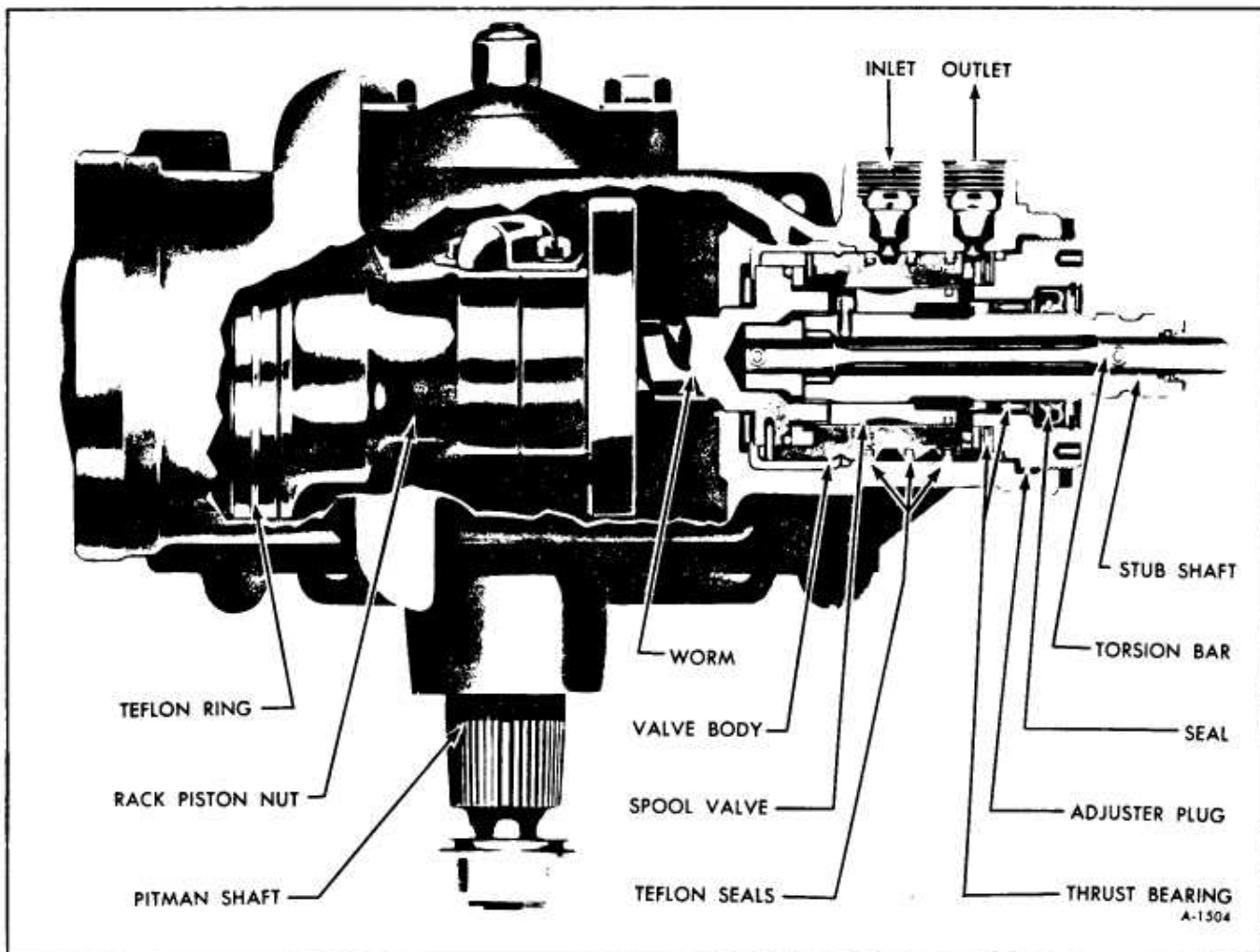

Figure 22—Power Steering Gear

ring and discard. If gasket seal is used, inspect, discard only if damaged.

5. Remove the rack-piston as follows:

a. Insert Ball Retainer Tool J-21552 into the rack-piston bore with pilot of tool seated in the end of the worm (figure 26). Turn stub shaft counterclockwise while holding tool tightly against worm. The rack-piston will be forced onto the tool. Hold tool and pull rack-piston farther onto tool to prevent end circuit balls from falling out.

b. Remove the rack-piston with Ball Retainer Tool J-21552 from gear housing.

6. Remove the adjuster plug as follows:

a. Loosen the adjuster plug locknut and remove.

b. Remove adjuster plug assembly with Spanner Wrench J-7624 (figure 27). Remove and discard the adjuster plug "O" ring.

7. Grasp the stub shaft and pull the valve assembly from the housing bore. Separate worm and valve and remove the lower shaft cap "O" ring and discard.

8. If the worm or the lower thrust bearing and race remained in the gear housing, remove them at this time.

ADJUSTER PLUG ASSEMBLY

Disassembly

1. If the oil seal ONLY is to be replaced, and not the bearing, install the adjuster plug (figure 28)

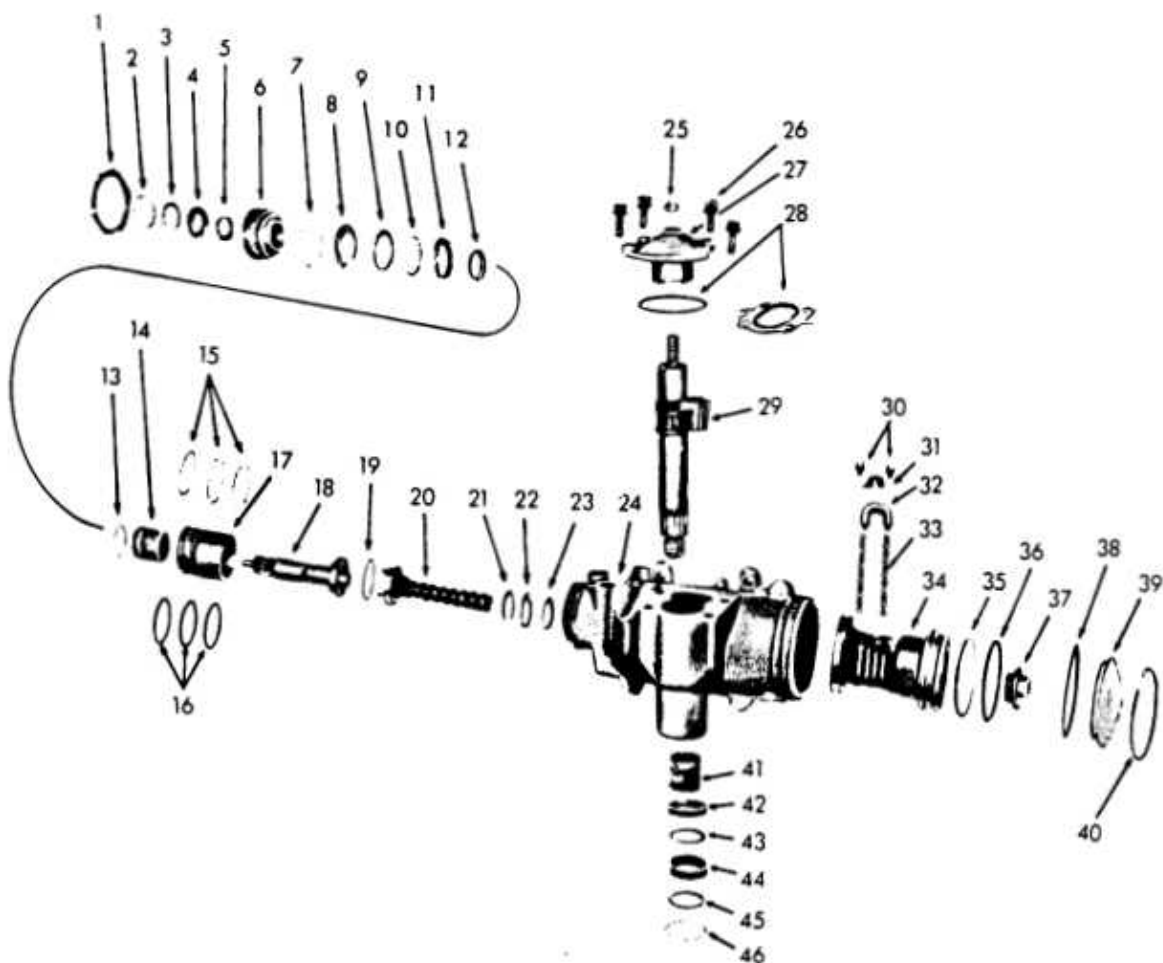

- | | | |
|--------------------------|--------------------------------|----------------------|
| 1 Locknut | 17 Valve Body | 32 Ball Return Guide |
| 2 Retaining Ring | 18 Stub Shaft | 33 Balls |
| 3 Dust Seal | 19 "O" Ring | 34 Rack-Piston |
| 4 Oil Seal | 20 Wormshaft | 35 Teflon Oil Seal |
| 5 Bearing | 21 Thrust Washer | 36 "O" Ring |
| 6 Adjuster Plug | 22 Thrust Bearing | 37 Plug |
| 7 "O" Ring | 23 Thrust Washer | 38 "O" Ring |
| 8 Thrust Washer (Large) | 24 Housing | 39 Housing End Cover |
| 9 Thrust Bearing | 25 Locknut | 40 Retainer Ring |
| 10 Thrust Washer (Small) | 26 Attaching Bolts and Washers | 41 Needle Bearing |
| 11 Spacer | 27 Side Cover | 42 Oil Seal |
| 12 Retainer | 28 "O" Ring | 43 Back Up Washer |
| 13 "O" Ring | 29 Pitman Shaft | 44 Oil Seal |
| 14 Spool Valve | 30 Screws and Lock Washers | 45 Back Up Washer |
| 15 Teflon Oil Rings | 31 Clamp | 46 Retaining Ring |
| 16 "O" Rings | | |

A-1505

Figure 23-Steering Gear (Exploded View)

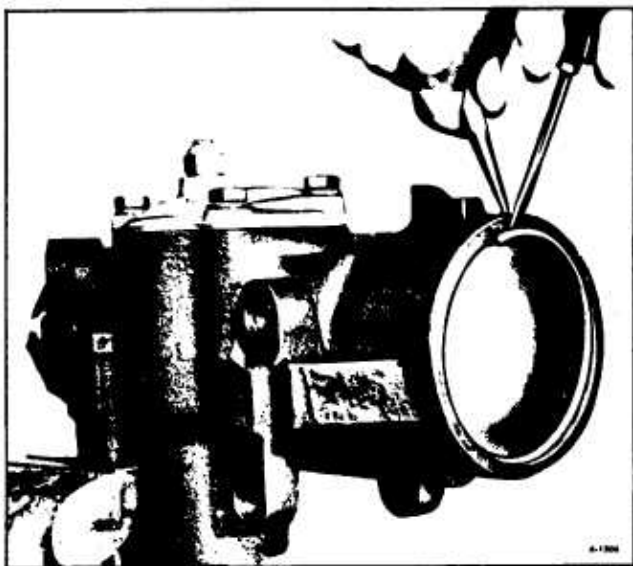

Figure 24—Removing End Cover

loosely in the gear housing. Remove the retaining ring with Internal Pliers J-4245. With a screw driver, pry the dust seal and oil seal from the bore of the adjuster plug being careful not to score the seal bore. Discard the oil seal.

2. If the thrust bearing **ONLY** is to be removed, pry the thrust bearing retainer at the two raised areas with a small screw driver (figure 29). Remove the spacer, thrust bearing washer, thrust bearing and washer.

3. If the needle bearing is to be replaced, remove the retaining ring using Internal Pliers J-4245. Remove thrust bearing as outlined in Step 2 above. Drive needle bearing, dust seal and oil seal from adjuster plug using Bearing Remover J-8524-2 and Driver J-7079-2 as shown in Figure 30. Discard the seals.

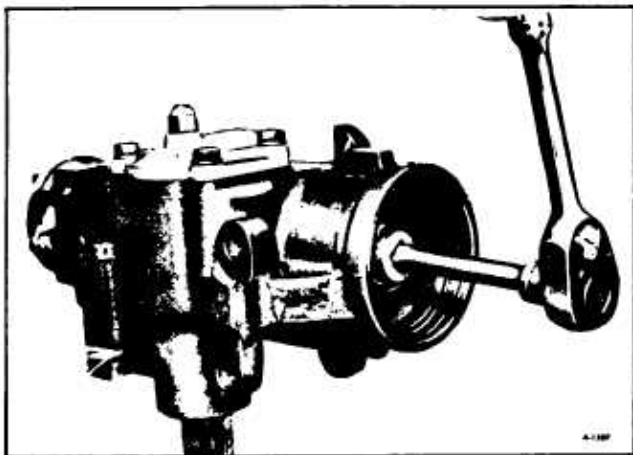

Figure 25—Removing Rack-Piston End Plug



Figure 26—Removing Rack Piston

4. Wash all parts in clean solvent and dry parts with compressed air.

5. Inspect thrust bearing spacer for wear or cracks. Replace if damaged.

6. Inspect thrust bearing rollers and thrust washers for wear, pitting or scoring. If any of these conditions exist, replace the bearing and thrust washers.

Assembly

1. If the needle bearing was removed, place new needle bearing over Tool J-8524-1 and J-7079-2, with the bearing manufacturer's identification against the tool, and drive the bearing into the adjuster plug until the tool bottoms in the housing (figure 31).

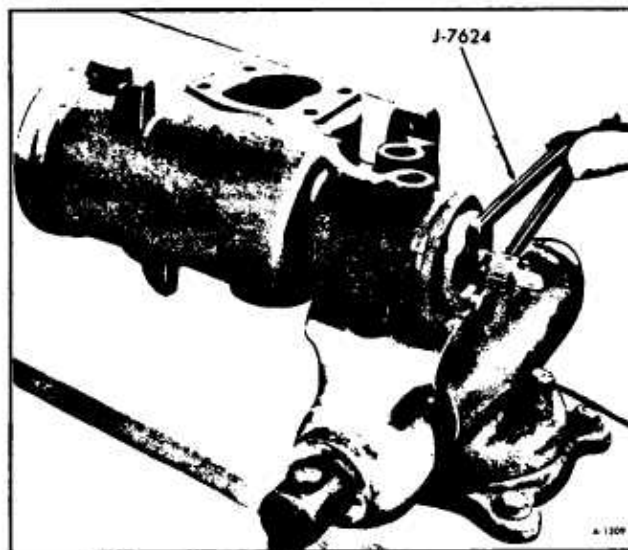

Figure 27—Removing Adjuster Plug

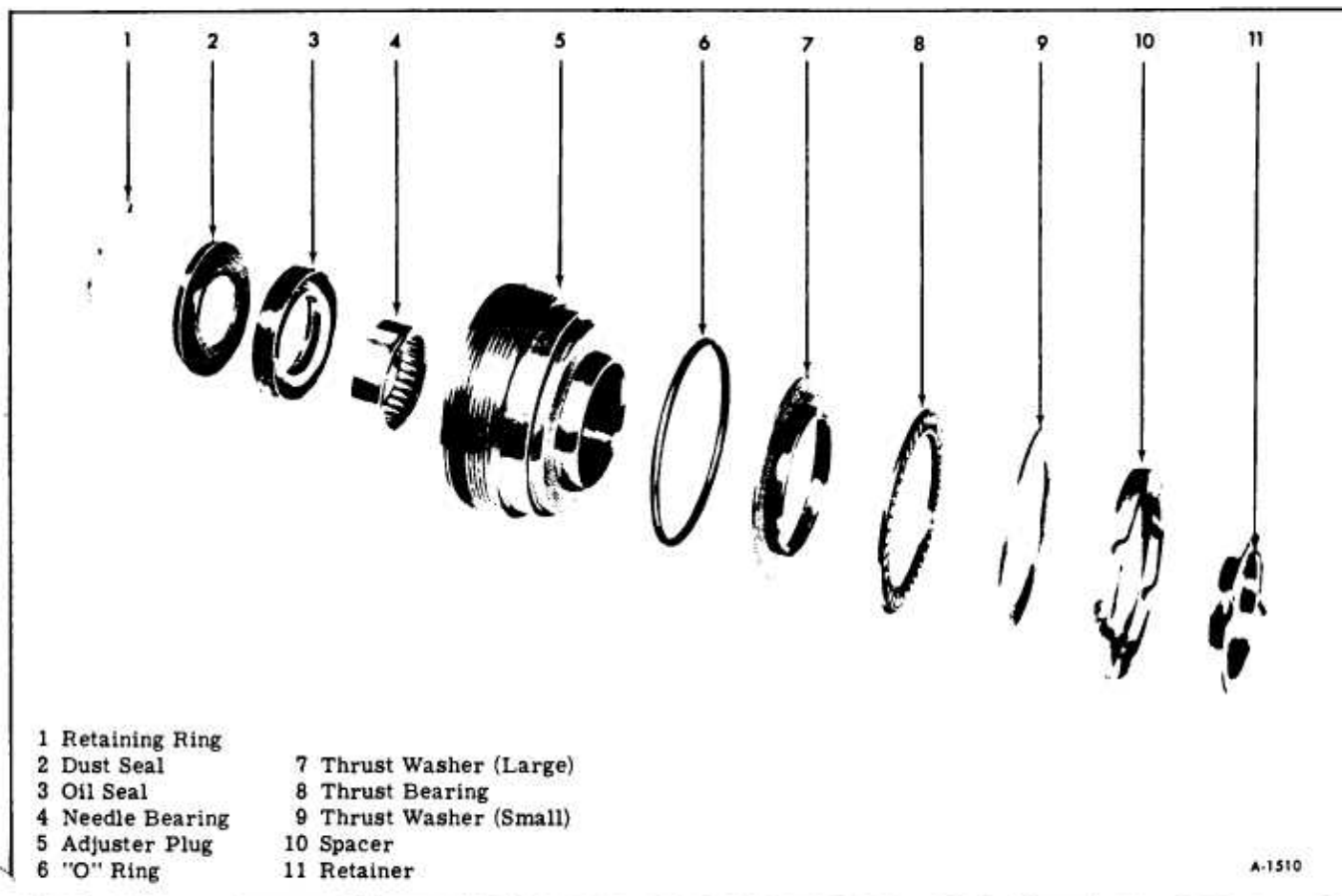

Figure 28—Adjuster Plug (Exploded View)

CAUTION: Place a block of wood under the adjuster plug to protect it during driving of the bearing.

2. Place dust seal and a new oil seal on Tool J-8524-1 (lip of seal away from tool). Lubricate seal

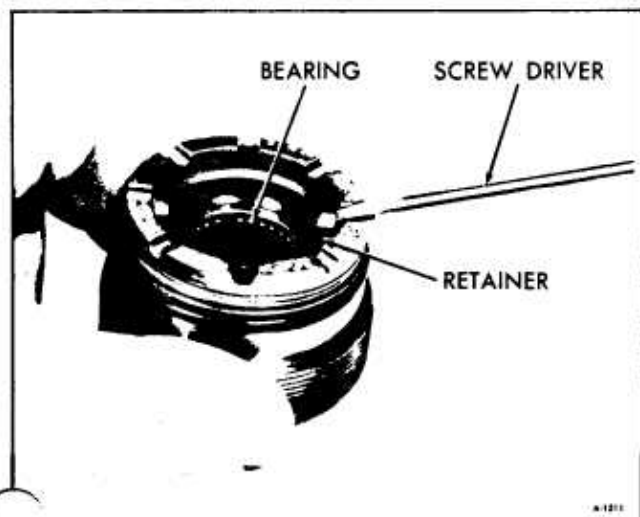

Figure 29—Removing Retainer

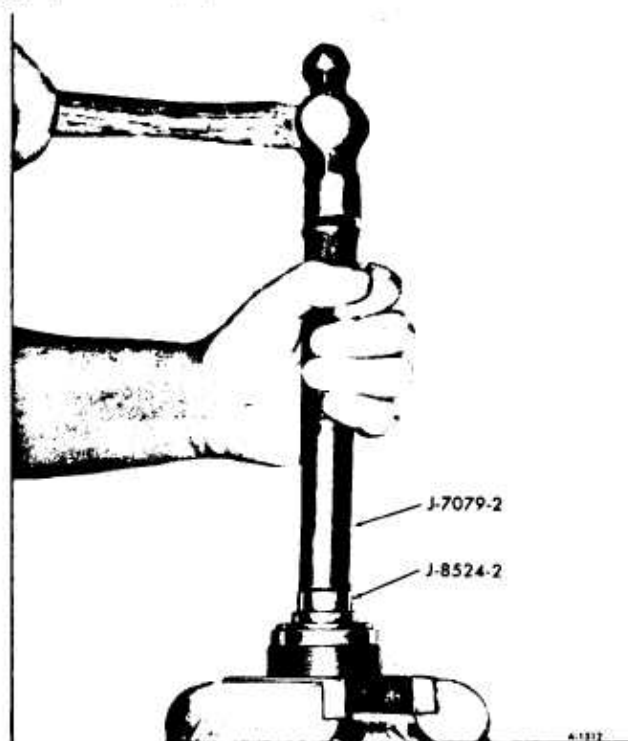

Figure 30—Removing Bearing and Seal

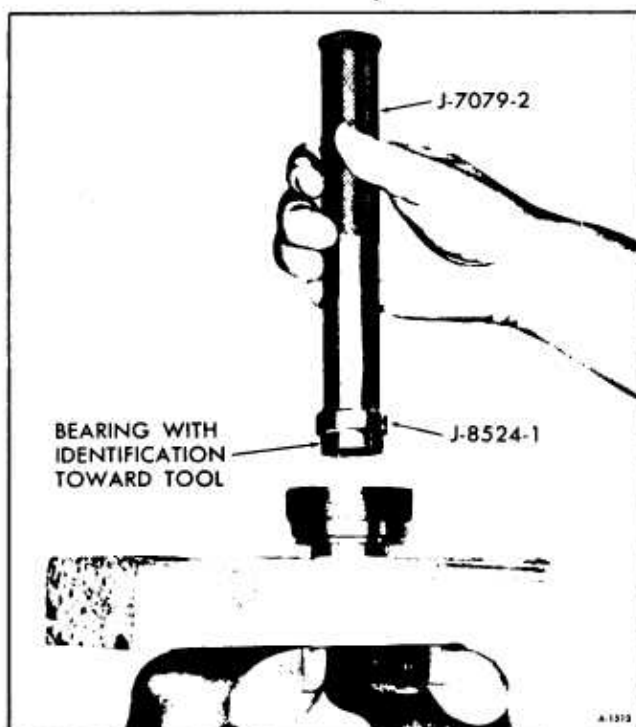

Figure 31—Installing Bearing

with Power Steering Fluid and drive or press seals into adjuster plug until seated (figure 32). When properly installed the oil seal is under the dust seal.

3. Install retaining ring with Internal Pliers J-4245.

4. Lubricate the thrust bearing assembly with Power Steering Fluid. Place the flanged thrust bearing washer on the adjuster plug hub, then install the upper thrust bearing, small bearing washer and spacer (grooves of spacer away from bearing washer).

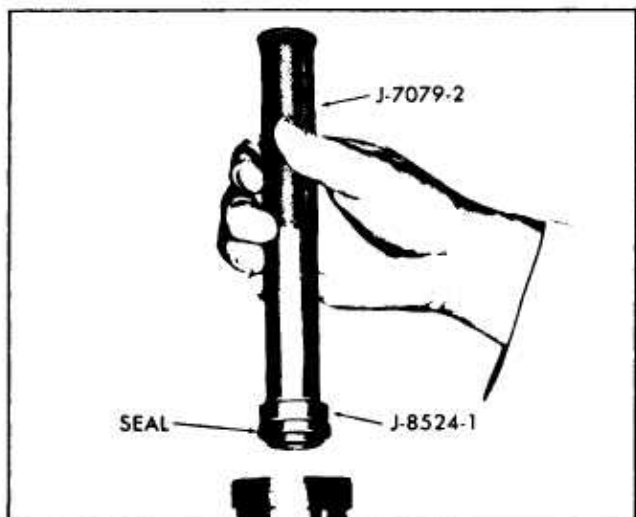

Figure 32—Installing Adjuster Plug Seal

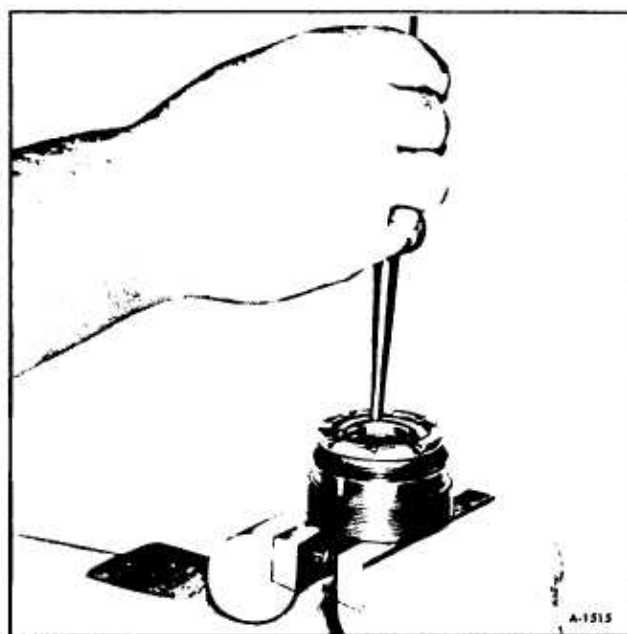

Figure 33—Install Retainer

5. Install bearing retainer on the adjuster plug by carefully tapping on the flat surface of the retainer (figure 33).

NOTE: The projections must not extend beyond the spacer when the retainer is seated. The spacer must be free to rotate.

VALVE AND STUB SHAFT ASSEMBLY

Disassembly

1. Remove and discard "O" ring in the shaft cap end of the valve assembly.

2. To remove the stud shaft assembly from the valve body, proceed as follows:

a. While holding the assembly (stub shaft down), lightly tap the stub shaft against the bench until the shaft cap is free from the valve body (figure 34).

b. Pull the shaft assembly until the shaft cap clears the valve body approximately 1/4".

CAUTION: Do not pull the shaft assembly out too far or the spool valve may become cocked in the valve body.

c. Carefully disengage the shaft pin from the valve spool and remove the shaft assembly (figure 34).

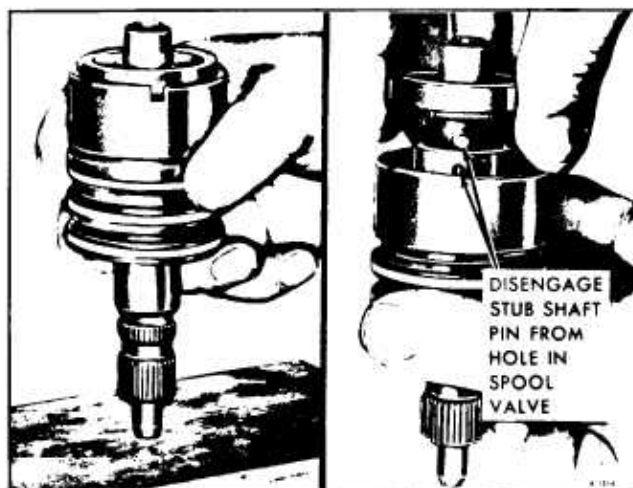

Figure 34—Removing Shaft Cap from Valve Body

3. Push the spool valve out of the flush end of the valve body until the dampener "O" ring is exposed then carefully pull the spool from the valve body, while rotating the valve (figure 35). If the spool valve becomes cocked, carefully realign the spool valve, then remove.

4. Remove the dampener "O" ring from the spool valve and discard.

5. If the teflon oil rings are to be replaced, cut the 3 teflon oil rings and "O" rings from the valve body and discard.



Figure 35—Removing Spool Valve

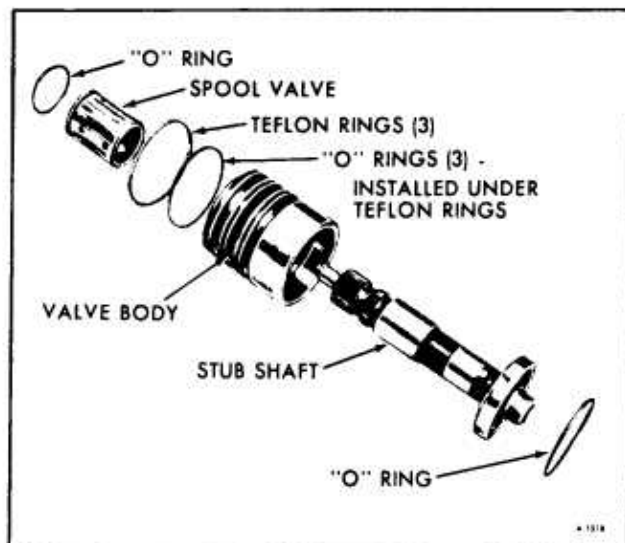

Figure 36—Valve Body and Shaft Assembly

Cleaning and Inspection (Figure 36)

1. Wash all parts in clean solvent and blow out all oil holes with compressed air.

2. If the drive pin in the stub shaft or valve body is cracked, excessively worn or broken, replace the complete valve and shaft assembly.

3. If there is evidence of leakage between the torsion bar and the stub shaft or scores, nicks, or burrs on the ground surface of the stub shaft that cannot be cleaned up with crocus cloth, the entire valve assembly must be replaced.

4. Check the outside diameter of the spool valve and the inside diameter of the valve body for nicks, burrs, or bad wear spots. If the irregularities cannot be cleaned up by the use of crocus cloth, the complete valve and shaft assembly will have to be replaced.

5. If the small notch in the skirt of the valve body is excessively worn, the complete valve assembly will have to be replaced. See Figure 37.

6. Lubricate the spool valve with Power Steering Fluid and check the fit of the spool valve in the valve body (with the spool valve dampener "O" ring removed). If the spool valve does not rotate freely without binding, the complete valve and shaft assembly will have to be replaced.

Assembly

1. If valve body "O" rings and teflon rings were removed, install 3 new "O" rings in the oil ring grooves and lubricate with Power Steering Fluid.

NOTCH IN END CAP MUST FULLY ENGAGE PIN PROJECTING INTO VALVE BODY

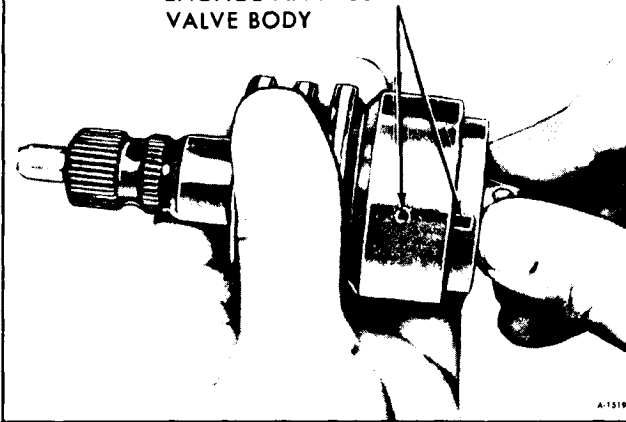

Figure 37—Installing Stub Shaft Assembly

2. Lubricate the 3 new teflon oil rings with Power Steering Fluid and install in grooves over “O” rings.

NOTE: The teflon rings may appear to be distorted, but the heat of the oil during operation of the gear will straighten them out.

3. Lubricate the spool valve dampener “O” ring with Power Steering Fluid and install over the spool valve.

4. Lubricate the spool valve and valve body with Power Steering Fluid and slide the spool valve into the valve body. Rotate the spool valve while pushing it into the valve body being careful not to cut the dampener “O” ring. Push the spool valve on through the valve body until the shaft pin hole is visible from the opposite end (spool valve flush with shaft cap end of valve body).

5. Lubricate the shaft assembly with Power Steering Fluid and carefully install it into the spool valve until the shaft pin can be placed into the spool valve.

6. Align the notch in the shaft cap with the pin in the valve body and press the spool valve and shaft assembly into the valve body (figure 37).

CAUTION: *Make sure that the shaft cap notch is mated with the valve body pin before installing valve body into the gear assembly.*

7. Lubricate a new cap to body “O” ring with Power Steering Fluid and install it in the shaft cap end of the valve body assembly.

PITMAN SHAFT AND SIDE COVER

Disassembly

Remove the locknut and unscrew the side cover from the adjusting screw. Do not attempt to disassemble pitman shaft. Discard locknut.

Cleaning and Inspection

1. Wash all parts in clean solvent and dry with compressed air.

2. Check pitman shaft bearing surface in the side cover for scoring. If badly worn or scored, replace the side cover assembly.

3. Check the sealing and bearing surfaces of the pitman shaft for roughness, nicks, etc. If minor irregularities in surface cannot be cleaned by use of crocus cloth, replace the pitman shaft.

4. Replace pitman shaft assembly if teeth are damaged or if the bearing surfaces are pitted or scored.

5. Check pitman shaft lash adjusting screw. It must be free to turn with no perceptible end play. If adjusting screw is loose replace the pitman shaft assembly.

Assembly

Thread the side cover onto the pitman shaft adjusting screw until it bottoms and then turn in 1/2 turn. Install a new adjusting screw locknut, but do not tighten.

RACK-PISTON

Cleaning and Inspection

1. Wash all parts in clean solvent and dry with compressed air.

2. Inspect the worm and rack-piston grooves and all the balls for scoring. If either the worm or rack-piston needs replacing, both must be replaced as a matched assembly.

3. Inspect ball return guide halves, making sure that the ends where the balls enter and leave the guides are not damaged.

4. Inspect lower thrust bearing and washers for scoring or excessive wear. If any of these conditions are found, replace the thrust bearing and washers.

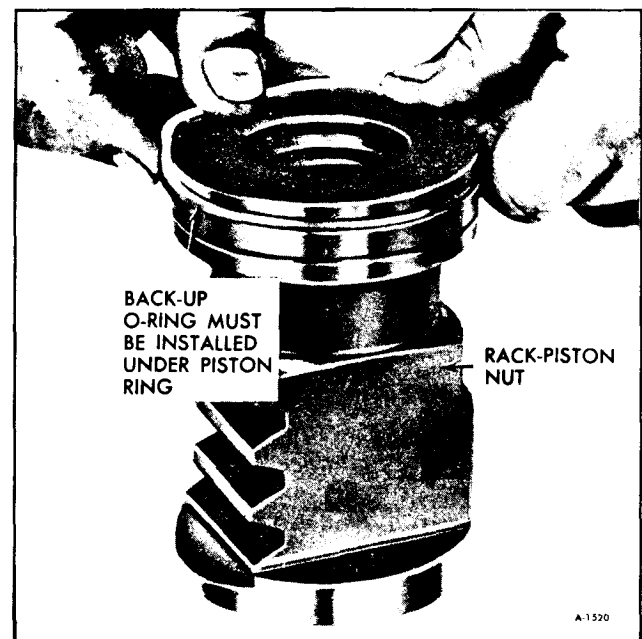

Figure 38—Installing Ring on Rack-Piston

5. Inspect rack-piston teeth for scoring or excessive wear. Inspect the external ground surfaces for wear, scoring or burrs. If any of these conditions exist and are excessive, both the rack-piston and worm must be replaced.

Assembly

1. If the teflon oil seal and "O" ring were removed, lubricate a new "O" ring and seal with

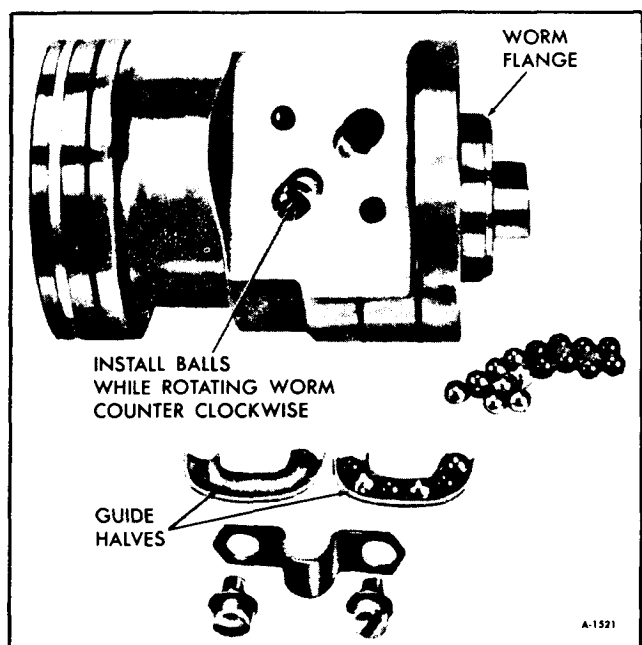

Figure 39—Installing Balls in Rack-Piston

Power Steering Fluid and install in groove on rack-piston. The teflon ring may be slightly loose after assembly, but will tighten up when subjected to the hot oil in the system (figure 38).

2. Slide the worm all the way into the rack-piston. It is not necessary to have the thrust bearing assembly on the worm at this time.

3. Turn the worm until the worm groove is aligned with the lower ball return guide hole (figure 39).

4. Lubricate the balls with Power Steering Fluid, then feed 17 balls into the rack-piston, while slowly rotating the worm counter-clockwise.

IMPORTANT: The black balls are .0005" smaller than the silver balls. The black and silver balls must be installed alternately into the rack-piston and return guide.

5. Alternately install 5 balls into the return guide and retain with grease at each end of guide. Install the return guide clamp and tighten the 2 clamp screws to 6 foot pounds.

STEERING GEAR HOSE CONNECTOR AND POPPET CHECK VALVE REPLACEMENT

The following procedure can be performed on vehicle as well as on bench.

1. Disconnect pressure and return line hoses at steering gear and secure hose ends in a raised position to prevent loss of fluid.

2. To prevent metal chips from becoming lodged in valve assembly, pack inside of connector seats of pressure and return ports with petrolatum.

3. Tap threads in connector seats, using a 5/16-18 tap.

CAUTION: Do not tap threads too deep in pressure hose connector seat as tap will bottom poppet valve against housing and damage it. It is necessary to tap only 2 or 3 threads deep.

4. Thread a 5/16-18 bolt with a nut and flat washer into tapped hole (figure 40).

5. To pull connector seat, hold bolt from rotating while turning nut off bolt. This will pull connector from housing. Discard connector seat.



Figure 40—Removing Hose Connector Seat

NOTE: It is also possible to remove connector by using a No. 4 screw extractor. (Easy out).

6. Wipe petrolatum from housing and clean housing thoroughly to remove any metal chips or dirt.

7. Remove poppet check valve and spring from pressure port and discard.

8. Install new check valve spring in pressure port with large end down. Make sure spring is seated in counterbore in pressure port (figure 41).

9. Install new check valve over spring with tangs pointing down. Make sure valve is centered on small end of spring.

10. Install new connector seats, using petrolatum to hold connector seat on check valve in pressure

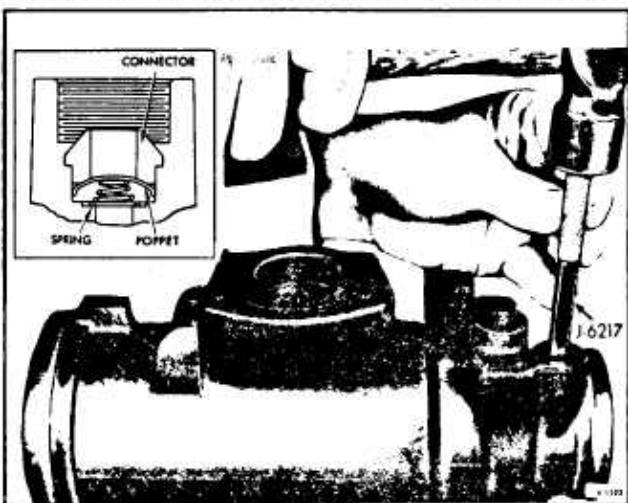

Figure 41—Installing New Connector

port. Drive connector seats in place using Valve Connector Seat Installer, J-6217 (figure 41).

11. Check operation of valve by pushing lightly against valve with a small punch or small rod. Valve should reseat itself against connector seat when pressure is removed from spring.

12. Connect pressure and return line hoses on steering gear. Tighten hose fittings to 30 foot-pounds.

13. Check fluid level in pump reservoir and add if necessary.

PITMAN SHAFT NEEDLE BEARING AND SEALS

Removal

CAUTION: When prying out seals, be extremely careful not to score the housing bore.

1. If pitman shaft seals ONLY are to be replaced, remove the seal retaining ring with Internal Pliers J-4245 and remove back-up washer. Using screw driver under lip of seal pry out the outer seal. Remove the back-up washer, then pry out the inner seal (figure 42). Discard seals.

2. If pitman shaft needle bearing replacement is necessary, remove with Tool J-6278. Since this bearing is shouldered, it must be pressed out the pitman shaft end of the housing.



Figure 42—Prying Out Inner Seal

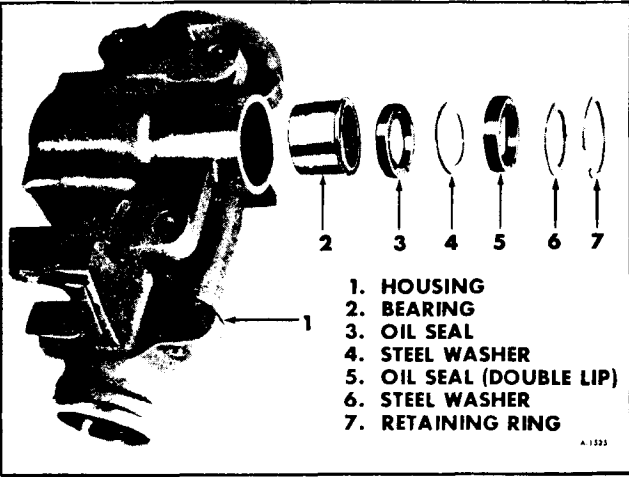

Figure 43-Pitman Shaft Bearing and Seals

Assembly

1. Thoroughly clean the parts (figure 43) and lubricate them with Power Steering Fluid.
2. Install pitman shaft needle bearing on Bearing Installer J-22407, with shoulder on bearing against tool. Position bearing and tool in housing and press bearing into housing until bottom edge of bearing is flush with the inner housing bore surface (figure 44).

CAUTION: Do not drive the bearing further into the housing after removing Tool J-22407, since damage to the bearing would result.

3. Lubricate the lips of the oil seals with Power Steering Fluid.

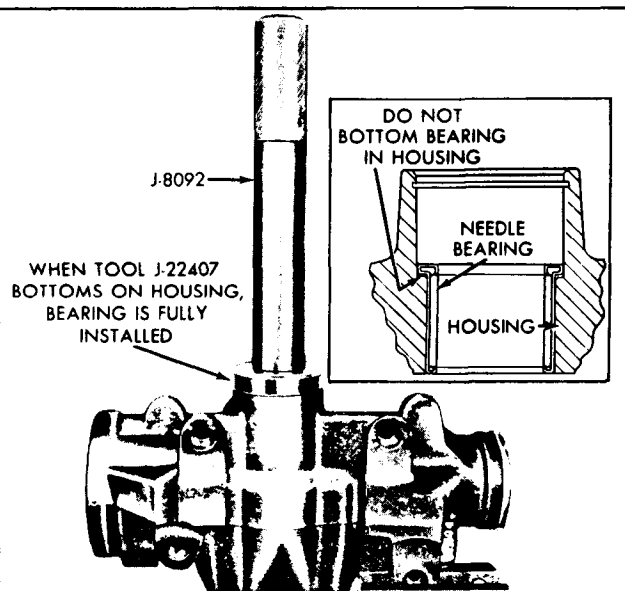

Figure 44-Installing Pitman Shaft Bearing

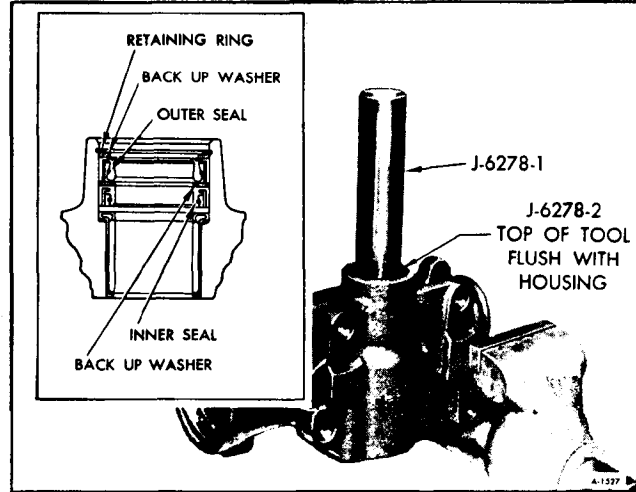

Figure 45-Installing Pitman Shaft Seals

4. Install the pitman shaft oil seals as follows:

- a. Place Adapter J-6278-2 over Tool J-6278, then install the outer seal (double lip), backup washer, and inner seal with the lips of the seals facing away from the adapter. (Seal identification toward adapter.)
- b. Drive the seals into the housing until the top of Adapter J-6278-2 is flush with the housing (figure 45).
- c. Remove the tool and adapter, then install the back-up washer and seal retaining ring. The retaining ring will not seat in the groove at this time.
- d. Reinsert Tool J-6278 with Adapter J-6278-2 and continue driving the seals until the retaining ring seats in its groove (Refer to inset, figure 45), then remove the tool and adapter.

REPLACEMENT OF PITMAN SHAFT SEALS WITH STEERING GEAR IN VEHICLE

If upon inspection of the gear, it is found that oil leakage exists at the pitman shaft seals, the seals may often be replaced without removing the gear assembly from the vehicle as follows:

1. Remove pitman nut and disconnect pitman arm from pitman shaft using Puller J-24319. Do not hammer on end of puller.
2. Thoroughly clean end of pitman shaft and gear housing, then tape splines on end of pitman shaft to insure that seals will not be cut by splines during assembly.

NOTE: Only one layer of tape should be used; an excessive amount of tape will not allow the seals to pass over it, due to the close tolerance between the seals and the pitman shaft.

3. Remove pitman shaft seal retaining ring with Snap Ring Pliers J-4245.

4. Start engine and turn steering wheel fully to the left so that oil pressure in the housing can force out pitman shaft seals. Turn off engine.

NOTE: Use suitable container to catch oil forced out of gear. This method of removing the pitman shaft seals is recommended, as it eliminates the possibility of scoring the housing while attempting to pry seals out.

5. Inspect seals for damage to rubber covering on O.D. If O.D. appears scored, inspect housing for burrs and remove before attempting new seal installation. Check seal surface of pitman shaft for roughness or pitting. If pitted replacement of pitman shaft is recommended.

6. Clean the end of housing thoroughly so that dirt will not enter housing with the installation of the new seals.

7. Lubricate the seals thoroughly with Power Steering Fluid to install seals with Installer J-6219 (figure 46). Install the inner single lip seal first, then a back-up washer. Drive seal in far enough to provide clearance for the outer seal, back-up washer and retaining ring. Make sure that the inner seal does not bottom on the counterbore. Install the outer double lip seal and the second back-up washer in only far

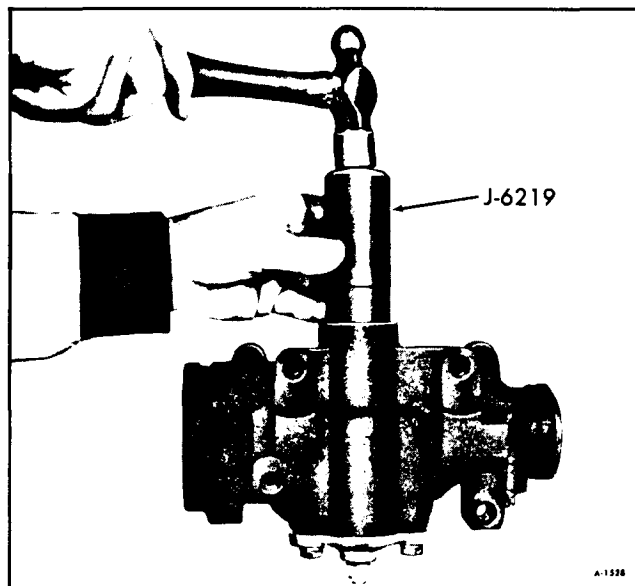

Figure 46—Installing Pitman Shaft Seals

enough to provide clearance for the retaining ring. Install retaining ring.

8. Fill pump reservoir to proper level with Power Steering Fluid. Start engine and allow engine to idle for at least three minutes without turning steering wheel. Turn wheel to left and check for leaks. Add Power Steering Fluid as required.

9. Remove tape and reconnect pitman arm.

NOTE: The pitman arm to steering gear nut and washer are important attaching parts in that they could affect the performance of vital components and systems, and/or could result in major repair expense. They must be replaced with the same part numbers or with equivalent parts if replacement becomes necessary. Do not use a replacement part of lesser quality or substitute design. Torque values must be used as specified during reassembly to assure proper retention.

STEERING GEAR ASSEMBLY

1. Lubricate the worm, lower thrust bearing and the two thrust washers with Power Steering Fluid, then install one thrust washer, the bearing, and the other thrust washer over the end of the worm (figure 47).

2. Lubricate the valve body teflon rings and a new cap to body "O" ring with Power Steering Fluid. Install the cap to body "O" ring in the valve body so it is seated against the lower shaft cap. Align the NARROW NOTCH in the valve body with pin in the worm, then install the valve and shaft assembly in the gear housing (figure 48). Apply pressure to the VALVE BODY when installing. If pressure is ap-

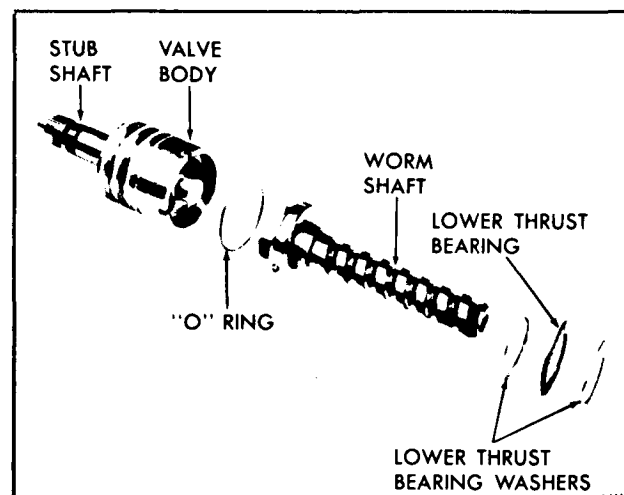

Figure 47—Worm and Valve Body

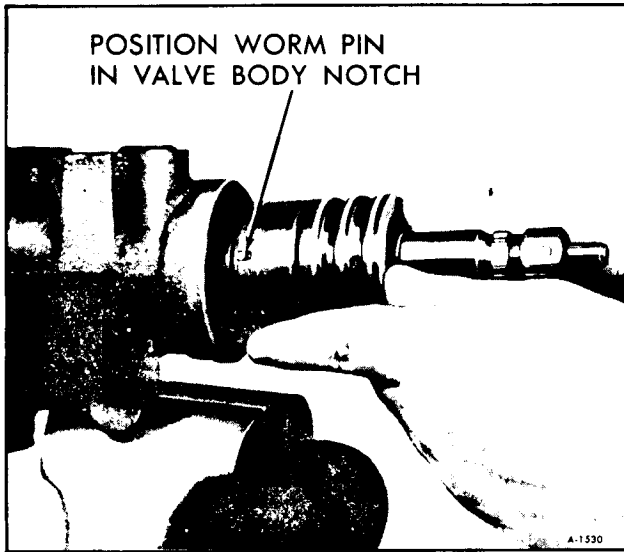

Figure 48-Valve to Worm Alignment

plied to the stub shaft during installation, the shaft may be forced out of the valve body (figure 49).

NOTE: The valve body is properly seated when the oil return hole in the housing is entirely uncovered (figure 50).

3. Lubricate a new adjuster plug "O" ring with Power Steering Fluid and install in groove on adjuster plug. Place Seal Protector J-6222 over stub shaft, then install the adjuster plug assembly in the housing until it seats against the valve body (figure 51). Remove Seal Protector.

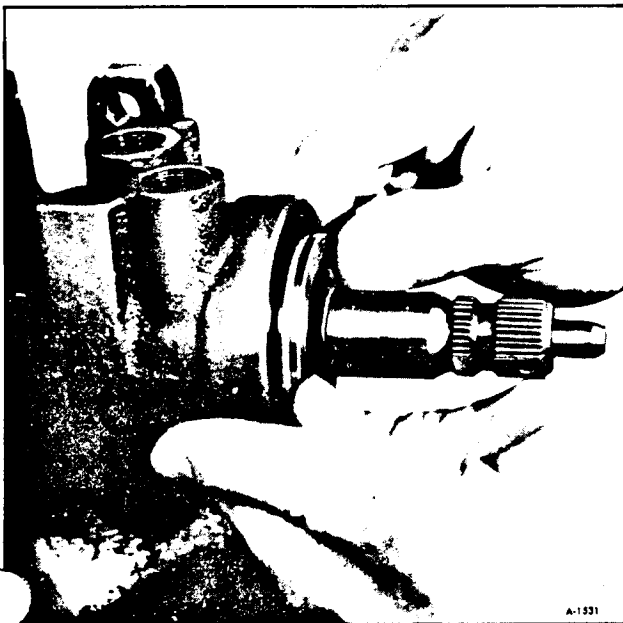

Figure 49-Installing Valve Body

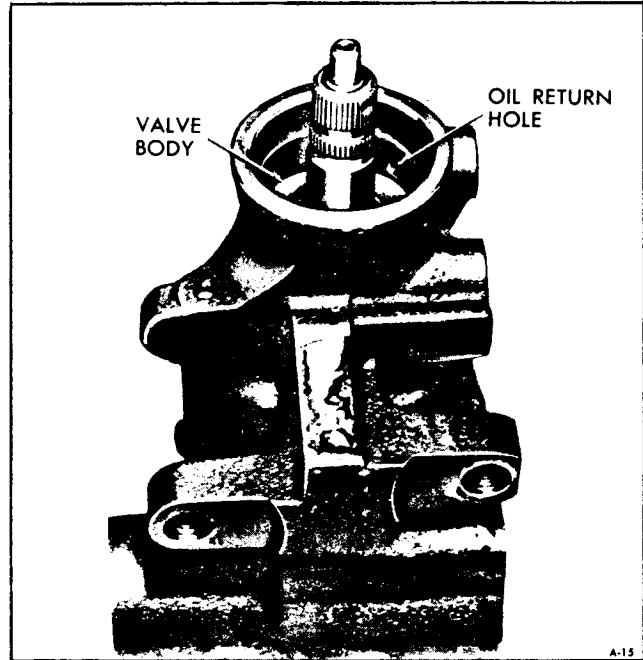

Figure 50-Valve Body in Housing

4. Adjust thrust bearing preload as follows:

a. Using spanner wrench J-7624, 3/4" 12 point socket and in-lb torque wrench tighten adjuster plug up snug (clockwise). Back adjuster plug off 1/4 turn and measure seal drag.

b. Adjust thrust bearing preload to obtain approximately 3-4 in. lbs. in excess of valve assembly drag. Tighten adjuster plug locknut securely while

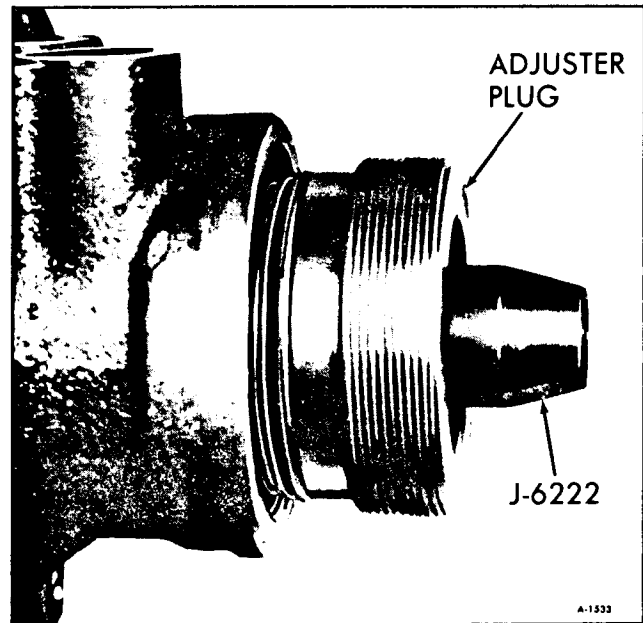

Figure 51-Installing Adjuster Plug

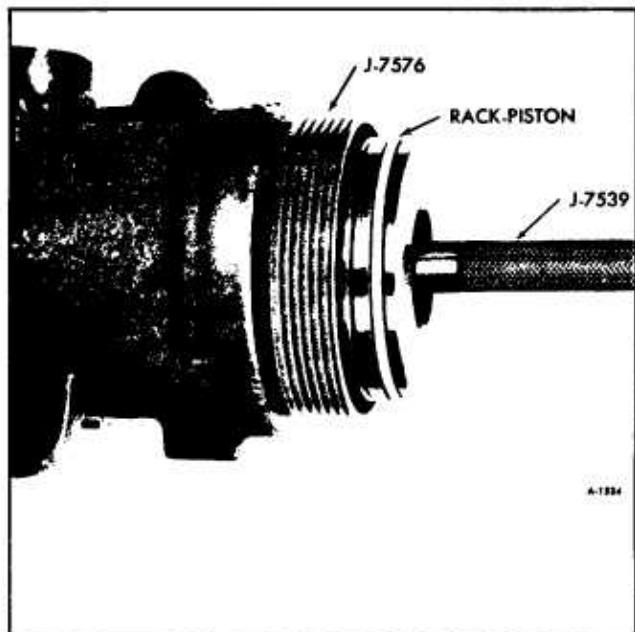

Figure 52—Installing Rack-Piston

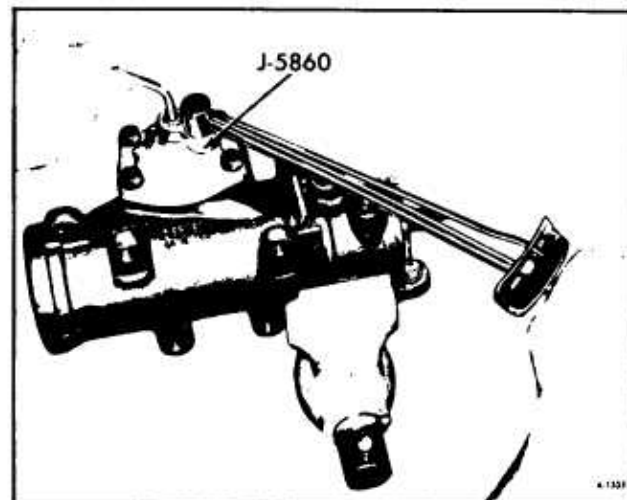

Figure 53—Torquing Over-Center Locknut

c. Install the side cover bolts and tighten to 35 foot pounds.

7. Install the rack-piston plug in the rack-piston and torque to 75 foot pounds.

8. Install a new housing end cover "O" ring and lubricate it with Power Steering Fluid. Install the end cover and retaining ring.

9. Adjust the over-center preload as follows:

a. Make sure the over-center adjusting screw is backed all the way out. Then turned back in 1/2 turn.

b. Install an inch-lb. torque wrench with a 3/4" 12-point socket on the stub shaft splines.

c. Rotate the stub shaft from one stop to the other. Count the number of turns and locate the center of travel, then check the combined ball and thrust bearing preload by rotating the torque wrench through the center of travel. Note the highest reading.

d. Tighten the pitman shaft over-center adjusting screw until the torque wrench reads 3-6 in. lbs. higher than the reading noted in Step c. The total reading should not exceed 14 in. lbs.

3. While holding the adjusting screw, tighten the locknut to 35 foot pounds using Adapter J-5860 (figure 53) and recheck the adjustment.

STEERING GEAR INSTALLATION

See CAUTION on page 9-1 of this section.

1. Before installing the steering gear, apply a sodium soap fine fiber grease to the gear mounting

holding adjuster plug in position with Tool J-7624. Recheck thrust bearing preload after tightening locknut.

5. Install the rack-piston as follows:

a. Lubricate the rack-piston teflon seal with Power Steering Fluid.

b. Position Seal Compressor J-7576 against the shoulder in the housing.

c. With Ball Retainer J-7539 in place in the rack-piston, push the rack-piston (with teeth toward pitman shaft opening), into the housing until Tool J-7539 contacts the center of worm (figure 52).

d. Turn the stub shaft clockwise with a 3/4" twelve point socket or box end wrench to thread the rack-piston onto the worm while holding Tool J-7539 against the end of the worm.

e. When the rack-piston is completely threaded on the worm, remove Ball Retainer J-7539 and Seal Compressor J-7576.

6. Install the pitman shaft and side cover as follows:

a. Install a new "O" ring in the side cover and retain with heavy grease.

b. Turn the stub shaft until the rack-piston teeth are centered in the pitman shaft opening, then install the pitman shaft and side cover so that the center tooth of the pitman shaft engages the center groove of the rack-piston.

ads to prevent squeaks between the gear housing and the frame. Make certain there is a minimum of .040" clearance between coupling yoke and steering gear upper seal.

2. Be sure the steering wheel is properly aligned in relation to the wheels, and tighten the yoke cinch bolt to 30 foot pounds. Tighten the steering gear to frame bolts to 70 foot pounds.

3. Install pitman arm on steering gear, secure with nut torqued to 160-210 foot-pounds.

4. Connect fluid pressure lines and bleed system. (Refer to ADJUSTMENTS under POWER STEERING PUMP earlier in this section).

STEERING GEAR ADJUSTMENTS

Adjustment of the steering gear in the vehicle is discouraged because of the difficulty encountered in adjusting the worm thrust bearing preload and the confusing effects of the hydraulic fluid in the gear. Since a gear adjustment is made only as a correction and not as a periodic adjustment, it is better to take the extra time and make the adjustment correctly the first time.

Since a handling stability complaint can be caused by improperly adjusted worm thrust bearings as well as an improper gear over-center adjustment, it is necessary that the steering gear assembly be removed from the vehicle and both thrust bearing and over-center preload be checked and corrected as necessary. An in-vehicle check of the steering gear will not pin-point a thrust bearing adjustment error.

A. Initial Checks

1. Remove gear from vehicle.
2. Drain oil from gear by rotating through its travel several times.
3. Check gear adjustment torque as removed from car as follows:
 - a. One-half turn off right and left stops.
 - b. One-half turn off center-right and left.
 - c. Over center (rotate through an arc 180 degrees each side of center-right and left).

B. Worm Thrust Bearing Adjustment

1. Loosen pitman shaft lash adjuster screw lock nut.

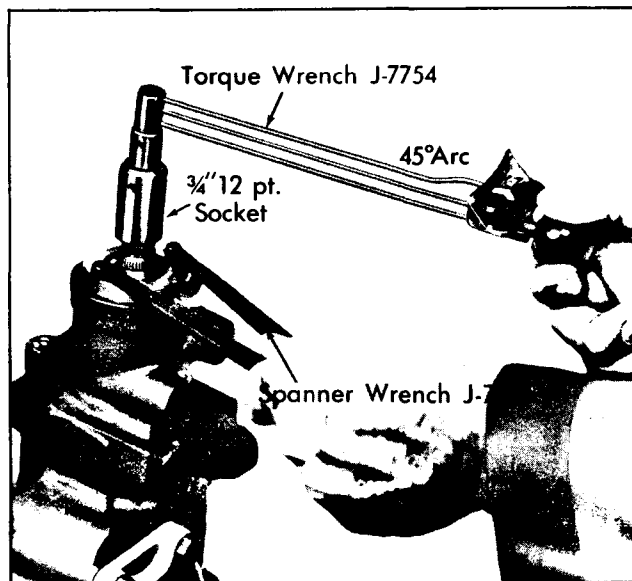

Figure 54-Adjusting Thrust Bearing Preload

2. Back off pitman shaft lash adjuster screw 1-1/2 turns and re-tighten lock nut.
3. Loosen thrust bearing adjuster plug lock nut.
4. Back off thrust bearing adjuster plug 1/4 turn.
5. Turn gear stub shaft to right and then back 1/2 turn.

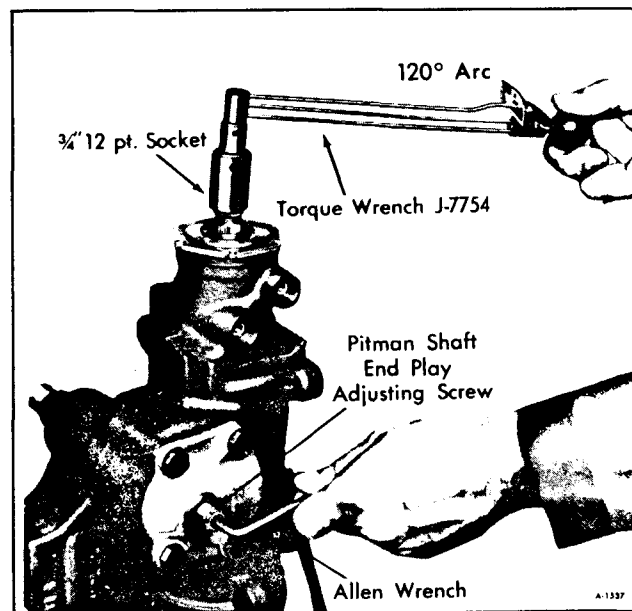

Figure 55-Pitman Shaft Over-Center Adjustment

6. Using an inch pound torque wrench on gear stub shaft, measure drag torque.

7. Tighten adjuster plug until torque to turn stub shaft is 3-4 lb. in greater than drag torque (with lock nut tightened). See Figure 54.

NOTE: Preload torque tends to drop off when the lock nut is tightened. Therefore, torque reading must be rechecked with the lock nut tight.

C. Pitman Shaft Over-Center Adjustment

1. With gear on center, loosen pitman shaft adjuster lock nut and tighten pitman shaft adjuster screw. Retighten lock nut (holding adjuster screw to keep it from turning) and measure gear over-center torque at stub shaft. When checking over-center

torque, torque wrench should be rotated through a 180 degree arc either side of center and readings taken going over-center. Continue adjusting adjuster screw and checking over-center torque (with lock nut tightened) until correct over-center torque is obtained. See Figure 55. Limits for new and old gears are different, as follows:

a. New gear over-center torque to be 4-8 inch-pounds additional torque, but total over-center torque must not exceed 18 inch-pounds.

b. Used gear (400 or more miles). Over-center torque to be 4-5 inch-pounds additional torque, but total over-center must not exceed 14 inch-pounds.

2. Record total over-center torque. This consists of over-center, thrust bearing, and drag torque.

STEERING COLUMN

CAUTION: *All column fasteners are important attaching parts in that they could affect the performance of vital components and systems, and/or could result in major repair expense. They must be replaced with parts of the same part numbers or with equivalent parts if replacement becomes necessary. Do not use replacement parts of lesser quality or substitute design. Torque values must be used as specified during re-assembly to assure proper retention of these parts.*

GENERAL INFORMATION AND OPERATION

The function locking energy-absorbing steering column includes three important features in addition to the steering function:

I. The column is energy-absorbing, designed to compress up to 8.25 inches in a front-end collision to minimize the possibility of injury to the driver of the vehicle.

II. The ignition switch and lock are mounted conveniently on the column.

III. With the column mounted lock, the ignition, steering and gearshifting operation can be locked to inhibit theft of the vehicle.

The function locking energy-absorbing steering column assembly is used on all vehicles. When a vehicle is being driven, the forward movement of the vehicle and the forward movement of the driver both constitute a form of kinetic energy. When a vehicle

is involved in a frontal collision, the primary force (forward movement of the vehicle) is suddenly halted, while the secondary force (the driver) continues its forward direction. A severe frontal collision generally involves these two forces—the primary and the secondary forces. The secondary impact occurs when the driver is thrust forward onto the steering wheel and column.

The function locking energy-absorbing column is designed to absorb these primary and secondary forces to the extent that the severity of the secondary impact is reduced.

The tilt function locking columns are designed for ease of entry and driver comfort. These columns have six or seven different steering wheel angle positions.

The tilt mechanism consists of an upper and lower steering shaft assembly with a universal joint between them. A support assembly is held to the mast jacket by a lock plate, and a bearing housing assembly is positioned over the upper steering shaft and secured to the support by two pivot pins. Two

lock shoes are pinned to the housing assembly and engage a pin in the support assembly. When the release lever is pulled up and the lock shoes disengage the support pin, the steering wheel is pushed up by a spring compressed between the support and housing assemblies.

The operation of the lock is the same as in other GM vehicles. To start the vehicle, you insert the key in the lock, turn the unit clockwise to "start" and let the switch return to the "on" position. The "off", "lock" and "accessory" positions are also the same as in other GM vehicles. When you engage the shift lever in "park" and lock the ignition, the steering wheel locks and the gearshift locks.

The function locking energy-absorbing column may be easily disassembled and reassembled. The serviceman should be aware that it is important that only the specified screws, bolts and nuts be used as designated and that they are tightened to their specified torque. This precaution will insure the energy

absorbing action of the assembly. Overlength bolts should not be used, as they may prevent a portion of the assembly from compressing under impact. Equally as important is correct torque of bolts and nuts. Care should be taken to assure that the bolts or nuts securing the column mounting bracket to the instrument panel are torqued to the proper specification in order that the bracket will break away under impact.

When the column is removed, special care must be taken in handling this assembly. Only the specified wheel puller should be used. When the column is removed from the vehicle, such actions as a sharp blow on the end of the steering shaft or shift lever, leaning on the column assembly, or dropping of the assembly could shear or loosen the plastic fasteners that maintain column rigidity. It is, therefore, important that the removal and installation and the disassembly and reassembly procedures be carefully followed when servicing the assembly.

STEERING COLUMN TROUBLE DIAGNOSIS

(STANDARD AND TILT STEERING COLUMNS)

LOCK SYSTEM DIAGNOSIS

Condition	Possible Cause	Correction
Will not unlock.	<ul style="list-style-type: none"> A. Shear flange on sector shaft collapsed. B. Lock bolt damaged. C. Defective lock cylinder. D. Damaged housing. E. Damaged sector. F. Damaged rack. 	<ul style="list-style-type: none"> A. Replace sector. B. Replace lock bolt. C. Replace lock cylinder. D. Replace housing. E. Replace sector. F. Replace rack.
Will not lock.	<ul style="list-style-type: none"> A. Lock bolt spring broken or defective. B. Damaged sector tooth. C. Defective lock cylinder. D. Burr on lock bolt or housing. E. Damaged housing. F. Transmission linkage adjustment incorrect. G. Damaged rack. H. Interference between bowl and rack coupling. I. Ignition switch stuck. J. Acutator rod restricted. 	<ul style="list-style-type: none"> A. Replace lock bolt spring. B. Replace sector. C. Replace lock cylinder. D. Remove burr. E. Replace housing. F. Readjust. G. Replace rack. H. Replace bowl or actuator rod as required. I. Replace ignition switch. J. Readjust.

STEERING COLUMN TROUBLE DIAGNOSIS (Cont'd.)

Condition	Possible Cause	Correction
High effort.	A. Lock cylinder defective. B. Ignition switch defective. C. Rack preload spring broken or deformed. D. Burrs on sector, rack, housing, support or actuator rod coupling. E. Bent sector shaft. F. Defective rack. G. Extreme misalignment of housing to cover. H. Distorted coupling slot in rack. I. Bent actuator rod. J. Ignition switch mounting bracket bent.	A. Replace lock cylinder. B. Replace ignition switch. C. Replace preload spring. D. Remove burr. E. Replace shaft. F. Replace rack. G. Replace either or both. H. Replace rack. I. Straighten or replace. J. Straighten or replace.
Will stick in "start".	A. Actuator rod deformed. B. Any high effort condition.	A. Straighten or replace. B. Check items under high effort section.
Key can not be removed in "off-lock".	A. Ignition switch is not set correctly. B. Defective lock cylinder.	A. Readjust. B. Replace lock cylinder.
Lock cylinder can be removed without depressing retainer.	A. Lock cylinder with defective retainer. B. Lock cylinder without retainer. C. Burr over retainer slot in housing cover.	A. Replace lock cylinder. B. Replace lock cylinder. C. Remove burr.

IGNITION SYSTEM DIAGNOSIS

Condition	Possible Cause	Correction
Electrical system will not function.	A. Poor battery connection. B. Connector body loose or defective. C. Defective wiring. D. Defective ignition switch. E. Ignition switch not adjusted properly.	A. Connect securely. B. Tighten or replace. C. Repair or replace. D. Replace ignition switch. E. Readjust.
Switch will not actuate mechanically.	A. Defective ignition switch.	A. Replace.

STEERING COLUMN TROUBLE DIAGNOSIS (Cont'd.)

Condition	Possible Cause	Correction
Switch can not be set correctly.	<p>A. Switch actuator rod deformed.</p> <p>B. Sector to rack en- in wrong tooth.</p>	<p>A. Repair or replace.</p> <p>B. Engage correctly.</p>

STEERING COLUMN

Condition	Possible Cause	Correction
Noise in column.	<p>A. Coupling bolts not tightened.</p> <p>B. Column not correctly aligned.</p> <p>C. Coupling pulled apart.</p> <p>D. Broken lower joint.</p> <p>E. Horn contact ring not lubricated.</p> <p>F. Lack of grease on bearings or bearing surfaces.</p> <p>G. Loose sight shields.</p> <p>H. Lower shaft bearing worn or broken.</p> <p>I. Upper shaft bearing worn or broken.</p> <p>J. Shaft lock plate cover loose.</p> <p>K. Shaft lock snap ring not seated.</p> <p>L. One click when in "off-lock" position and the steering wheel is moved.</p>	<p>A. Tighten pinch bolts to 30 foot pounds.</p> <p>B. Realign column.</p> <p>C. Realign column and replace coupling.</p> <p>D. Repair joint using kit #7810077 and realign column.</p> <p>E. Lubricate with lubriplate.</p> <p>F. Lubricate.</p> <p>G. Bend to eliminate rattle.</p> <p>H. Replace bearing. Check shaft and replace if scored.</p> <p>I. Replace bearing assembly.</p> <p>J. Tighten three screws to 15 in.-lbs., or if missing, replace. Caution: Use specified screws.</p> <p>K. Replace snap ring. Check for proper seating in groove.</p> <p>L. Normal-lock bolt is seating.</p>
High steering shaft effort.	<p>A. Column assembly mis-aligned.</p> <p>B. Improperly installed or deformed dust seal.</p> <p>C. Defective upper or lower bearing.</p> <p>D. Flash on I.D. of shift tube from plastic joint.</p> <p>E. Tight steering uni- versal joint.</p>	<p>A. Realign.</p> <p>B. Install new seal.</p> <p>C. Replace.</p> <p>D. Replace shift tube.</p> <p>E. Repair or replace.</p>
High shift effort.	<p>A. Column not aligned correctly in vehicle.</p>	<p>A. Realign.</p>

STEERING COLUMN TROUBLE DIAGNOSIS (Cont'd.)

Condition	Possible Cause	Correction
	B. Wave washer with burrs. C. Improperly installed dust seal. D. Lack of grease on seal or bearing. E. Improper screws used for ignition switch, neutral start switch or mounting bracket. F. Burr on upper or lower end of shift tube.	B. Replace. C. Remove and replace. D. Lubricate. E. Use correct fasteners. F. Remove burr.
Improper transmission shifting.	A. Sheared shift tube joint or lower shift lever weld. B. Improper transmission linkage adjustment.	A. Replace tube assembly. B. Readjust.
Miscellaneous.	A. Housing loose on jacket--will be noticed with ignition in "off-lock" and a torque applied to the steering wheel.	A. Tighten four mounting screws 60 in.-lbs.
Lash in mounted column assembly.	A. IP to column bracket mounting bolts loose. B. Broken weld nuts on jacket. C. IP bracket capsule sheared. D. Loose shoes in housing. E. Loose tilt head pivot pins. F. Loose shoe lock pin in support. G. Loose support screws. H. Column bracket to jacket bolts loose.	A. Tighten to 20 foot pounds. B. Replace jacket assembly. C. Replace bracket assembly. D. Replace shoes. E. Replace pivot pins. F. Replace pin. G. Tighten to 60 in.-lbs. H. Tighten to 15 foot pounds.
Housing scraping on bowl.	A. Bowl bent or not concentric with hub.	A. Replace bowl.
Steering wheel loose.	A. Excessive clearance between holes in support or housing and pivot pin diameters. B. Defective or missing anti-lash spring in spheres. C. Upper bearing not seating in bearing. D. Upper bearing inner race seat missing.	A. Replace either or both. B. Add spring or replace both. C. Replace both. D. Install seat.

STEERING COLUMN TROUBLE DIAGNOSIS (Cont'd.)

Condition	Possible Cause	Correction
	<p>E. Improperly adjusted tilt locking knob.</p> <p>F. Loose support screws.</p> <p>G. Bearing preload spring missing or broken.</p>	<p>E. Readjust.</p> <p>F. Tighten 60 in.-lbs.</p> <p>G. Replace preload spring.</p>
Steering wheel loose—every other tilt position.	A. Loose fit between shoe and shoe pivot pin.	A. Replace both.
Steering column not locking in any tilt position.	<p>A. Shoe seized on its pivot pin.</p> <p>B. Shoe grooves may have burrs or dirt.</p> <p>C. Shoe lock spring weak or broken.</p>	<p>A. Replace both.</p> <p>B. Replace shoe.</p> <p>C. Replace lock spring.</p>
Steering wheel fails to return to top tilt position.	<p>A. Pivot pins are bound up.</p> <p>B. Wheel tilt spring is defective.</p> <p>C. Turn signal switch wires too tight.</p>	<p>A. Replace pivot pins.</p> <p>B. Replace tilt spring.</p> <p>C. Readjust.</p>
Noise when tilting column.	<p>A. Upper tilt bumpers worn.</p> <p>B. Tilt spring rubbing in housing.</p>	<p>A. Replace tilt bumper.</p> <p>B. Lubricate.</p>

SIGNAL SWITCH DIAGNOSIS

Condition	Possible Cause	Correction
Turn signal will not cancel.	<p>A. Loose switch mounting screws.</p> <p>B. Switch or anchor bosses broken.</p> <p>C. Broken, missing or out of position detent, return or cancelling spring.</p> <p>D. Uneven or incorrect cancelling cam to cancelling spring interference. (.120)/side.</p>	<p>A. Tighten to specified torque (25 in.-lbs.).</p> <p>B. Replace switch.</p> <p>C. Reposition or replace springs as required.</p> <p>D. Adjust switch position. <ol style="list-style-type: none"> 1. If interference is correct and switch will still not cancel, replace switch. 2. If interference cannot be corrected by switch adjustment, replace cancelling cam. </p>

STEERING COLUMN TROUBLE DIAGNOSIS (Cont'd.)

Condition	Possible Cause	Correction
Turn signal difficult to operate.	A. Actuator rod loose. B. Yoke broken or distorted. C. Loose or misplaced D. Foreign parts and/or materials. E. Switch mounted loosely.	A. Tighten mounting screw (12 in.-lb.). B. Replace switch. C. Reposition or replace springs. D. Remove foreign parts and/or material. E. Tighten mounting screws (25 in.-lbs.).
Turn signal will not indicate lane change.	A. Broken lane change pressure pad or spring hanger. B. Broken, missing or misplaced lane change spring. C. Jammed base or wires.	A. Replace switch. B. Replace or reposition as required. C. Loosen mounting screws, reposition base or wires and retighten screws (25 in.-lbs.).
Turn signal will not stay in turn position.	A. Foreign material or loose parts impeding movement of yoke. B. Broken or missing detent or cancelling springs. C. None of the above.	A. Remove material and/or parts. B. Replace spring. C. Replace switch.
Hazard switch cannot be turned off.	A. Foreign material between hazard support cancelling leg and yoke.	A. Remove foreign material. 1. No foreign material impeding function of hazard switch—replace turn signal switch.
Hazard switch will not stay on or difficult to turn off.	A. Loose switch mounting screws. B. Interference with other components. C. Foreign material. D. None of the above.	A. Tighten mounting screws (25 in.-lbs.). B. Remove interference. C. Remove foreign material. D. Replace switch.
No turn signal lights.	A. Defective or blown fuse. B. Inoperative turn signal flasher. C. Loose chassis to column connector. D. *Disconnect column to chassis connector. Connect new switch to chassis and operate switch by hand. If vehicle lights now operate normally, signal switch is inoperative. E. If vehicle lights do not operate check chassis wiring for opens, grounds, etc.	A. Replace fuse. B. Replace turn signal flasher. C. Connect securely. D. Replace signal switch. E. Repair chassis wiring as required using manual as guide.

STEERING COLUMN TROUBLE DIAGNOSIS (Cont'd.)

Condition	Possible Cause	Correction
Turn indicator lights on, but not flashing.	<p>A. Inoperative turn flasher.</p> <p>B. Loose chassis to column connection.</p> <p>C. Inoperative turn signal switch.</p> <p>D. To determine if turn signal switch is defective, substitute new switch into circuit and operate switch by hand. If the vehicle's lights operate normally, signal switch is inoperative.</p> <p>E. If the vehicle's lights do not operate, check light sockets for high resistance connections, the chassis wiring for opens, grounds, etc.</p>	<p>A. Replace turn flasher. Note: There are two flashers in the system. Consult manual for location.</p> <p>B. Connect securely.</p> <p>C. Replace turn signal switch.</p> <p>D. Replace signal switch.</p> <p>E. Repair chassis wiring as required using manual as guide.</p>
Front or rear turn signal lights not flashing.	<p>A. Burned out or damaged turn signal bulb.</p> <p>B. High resistance connection to ground at bulb socket.</p> <p>C. Loose chassis to column connector.</p> <p>D. Disconnect column to chassis connector. Connect new switch into system and operate switch by hand. If turn signal lights are now on and flash, turn signal switch is inoperative.</p> <p>E. If vehicle lights do not operate, check chassis wiring harness to light sockets for opens, grounds, etc.</p>	<p>A. Replace bulb.</p> <p>B. Remove or repair defective connection.</p> <p>C. Connect securely.</p> <p>D. Replace turn signal switch.</p> <p>E. Repair chassis wiring as required using manual as guide.</p>
Stop light not on when turn indicated	<p>A. Loose column to chassis connection.</p> <p>B. Disconnect column to chassis connector. Connect new switch into system without removing old. Operate switch by hand. If brake lights work with switch in the turn position, signal switch is defective.</p>	<p>A. Connect securely.</p> <p>B. Replace signal switch.</p>

STEERING COLUMN TROUBLE DIAGNOSIS (Cont'd.)

Condition	Possible Cause	Correction
	<p>C. If brake lights do not work check connector to stop light sockets for grounds, opens, etc.</p>	<p>C. Repair connector to stop light circuits using manual as guide.</p>
<p>Turn indicator panel lights not flashing.</p>	<p>A. Burned out bulbs. B. High resistance to ground at bulb socket. C. Opens, grounds in wiring harness from front turn signal bulb socket to indicator lights.</p>	<p>A. Replace bulbs. B. Replace socket. C. Locate and repair as required. Use shop manual as guide.</p>
<p>Turn signal lights flash very slowly.</p>	<p>A. Inoperative turn signal flasher. B. System charging voltage low. C. High resistance ground at light sockets. D. Loose chassis to column connection. E. Disconnect column to chassis connector. Connect new switch into system without removing old. Operate switch by hand. If flashing occurs at normal rate, the signal switch is defective. F. If the flashing rate still extremely slow, check chassis wiring harness from the connector to light sockets for grounds, high resistance points, etc.</p>	<p>A. Replace turn signal flasher. B. Increase voltage to specified. Use manual. C. Repair high resistance grounds at light sockets. D. Connect securely. E. Replace signal switch. F. Locate and repair as required. Use manual as guide.</p>
<p>Hazard signal lights will not flash—turn signal functions normally.</p>	<p>A. Blown fuse. B. Inoperative hazard warning flasher. C. Loose chassis to column connection. D. Disconnect column to chassis connector. Connect new switch into system without removing old. Depress the hazard warning button and observe the hazard warning lights. If they now work normally, the turn signal switch is defective.</p>	<p>A. Replace fuse. B. Replace hazard warning flasher. C. Connect securely. D. Replace the turn signal switch.</p>

STEERING COLUMN TROUBLE DIAGNOSIS (Cont'd.)

Condition	Possible Cause	Correction
	E. If the lights do not flash, check wiring harness "K" lead (brown) for open between hazard flasher and harmonica connector. If open, fuse block is defective.	E. Replace fuse block.

KEY BUZZER DIAGNOSIS

Condition	Possible Cause	Correction
Buzzer does not sound with key fully inserted in lock cylinder with the entrance door open.	<p>A. Defective buzzer.</p> <p>B. Bad connection at buzzer.</p> <p>C. Power not available to buzzer.</p> <p>D. Door jamb switch misadjusted or in-operative.</p> <p>E. Short in chassis wiring.</p>	<p>A. Replace buzzer.</p> <p>B. Connect securely.</p> <p>C. Check continuity of chassis wiring and repair as required.</p> <p>D. Readjust or replace—as required.</p> <p>E. Check by separating chassis to column connector. Connect "E" (black) and "F" (black w/pink stripe) female contacts on the chassis side (figure 56). Bent paper clip will work if buzzer sounds, continue diagnosis. If not, locate, and repair chassis wiring, use manual as guide.</p>

NOTE 1: If the buzzer fault has not yet been detected, connect a continuity meter (light) to the male "E" and "F" connector contacts (figure 57). Insert the key the full depth into the lock cylinder.

If contact is made with the key in, and is not made with it out, the function is normal. Retrace initial diagnostic steps.

If contact is not established, the fault is in the column. Proceed to Note 2.

NOTE 2: With the fault isolated in the column, disassemble the upper end of the column until the signal switch mounting screws have been removed. Lift the switch and check the probes of the buzzer switch to insure good contact with the pads on the signal switch. Bend probes, if required, then reseal the signal switch and drive the three screws. Check the function, as in Note 1.

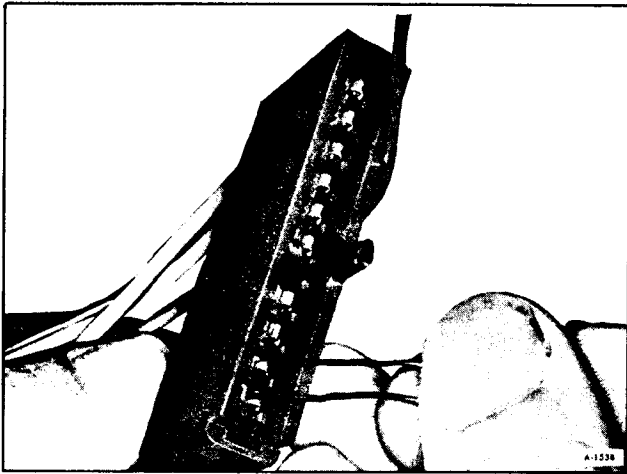

Figure 56—Checking For Short In Chassis Wiring

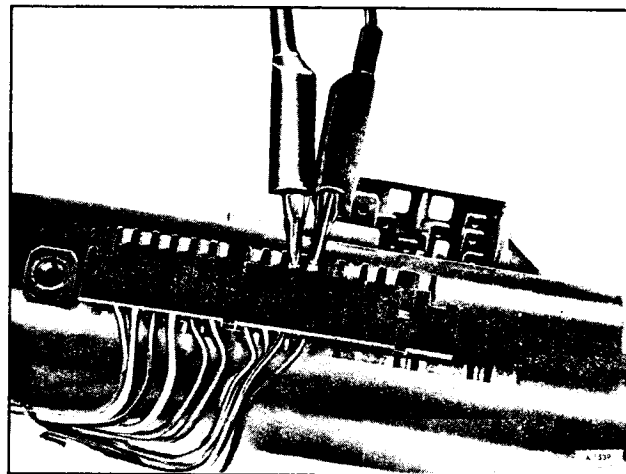

Figure 57—Checking Column Buzzer Circuit Continuity

STEERING COLUMN TROUBLE DIAGNOSIS (Cont'd.)

Condition	Possible Cause	Correction
Buzzer does not sound with key fully inserted in lock cylinder with the entrance door open.	F. Short or fault in signal switch wiring.	F. Connect male "E" and "F" contacts of connector with jumper (figure 58). Check buzzer switch pads with continuity meter. If contact is made, function is normal. If not, replace signal switch.

NOTE 3: If the fault has not yet been isolated and repaired, connect a continuity meter to the buzzer switch probes (figure 59). Fully insert and remove the key from the lock cylinder.

If contact is made with the key in, and is broken with it out, the function is normal. Retrace diagnostic steps starting at Note 2.

If contact is not made, the fault is in the lock cylinder or buzzer switch.

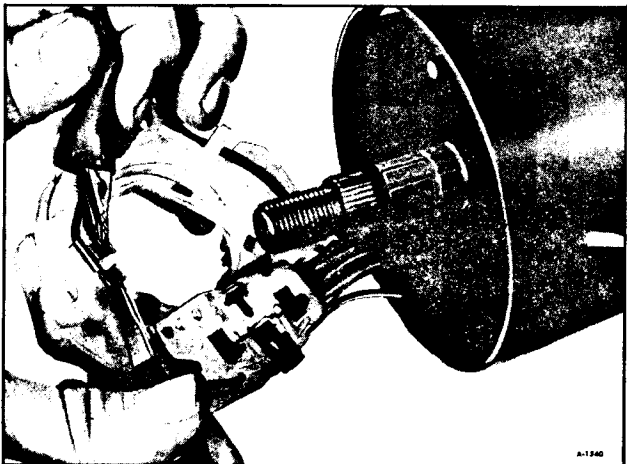

Figure 58—Checking Buzzer Switch Pads

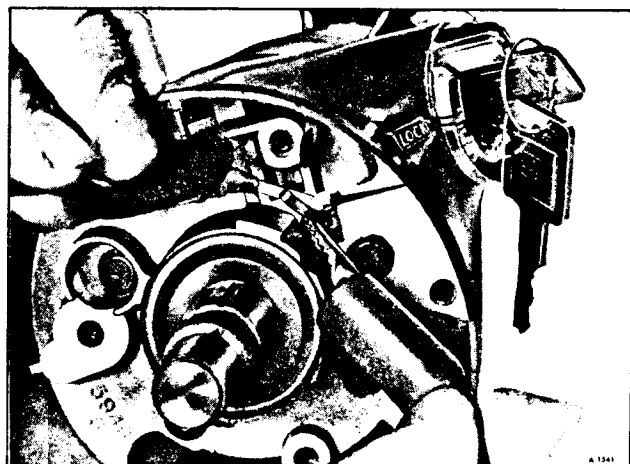

Figure 59—Checking Buzzer Switch Continuity

STEERING COLUMN TROUBLE DIAGNOSIS (Cont'd.)

Condition	Possible Cause	Correction
Buzzer does not sound with the key fully inserted in lock cylinder with the entrance door open.	<p>G. Chips, burrs, foreign material preventing actuator tip function. Caution: Key must be removed or cylinder in "run" position before removing lock cylinder.</p> <p>H. Defective lock</p> <p>I. Chips, foreign material affecting buzzer switch operation.</p> <p>J. Damaged or broken buzzer switch.</p> <p>K. Switch appears good but will not make buzzer switch function check.</p> <p>L. Buzzer switch contact gap too large.</p>	<p>G. Remove chips, burrs, etc. Reassemble and re-check ref. note 3.</p> <p>H. With the lock cylinder out (observing caution under G), fully insert and remove the key. The actuator (figure 60 and 61) should extend and retract smoothly. Total extension of tip should be .050 in. If not, replace lock cylinder.</p> <p>I. Remove and clean as required—reassemble and re-check per note 3.</p> <p>J. Replace buzzer switch.</p> <p>K. Connect continuity meter leads to the buzzer switch probes. Press on the actuator pad until the interior points contact. (figure 62). If contact is not made, replace buzzer switch.</p> <p>L. Reset contact gap.</p>

NOTE 4: Setting the contact gap. Press a .030 wire type spark plug gap wire with flat piece of stock on the actuator pad. (figure 63) If contact is not made adjust switch as shown in Figure 64, until positive contact is made. (Use continuity meter).

With positive contact at .030, use a .025 plug gap wire beneath the flat stock (figure 65). No contact should occur. Adjust as shown in Figure 66. When the switch will make contact with the .030 wire and not with the .025, the buzzer switch is set at the low limit.

Condition	Possible Cause	Correction
Buzzer continues to operate with key in the lock cylinder with the entrance door either opened or closed and ceases when key is removed.	<p>A. Door jamb switch misadjusted or inoperative. or inoperative.</p> <p>B. Wire from signal switch to door jamb switch shorted.</p>	<p>A. Adjust or replace as required.</p> <p>B. If on signal switch side, replace signal switch. If on chassis side, find and repair—use manual.</p>

NOTE5: This condition indicates the lock cylinder or buzzer switch is at fault. To verify, check for continuity at the "E" "F" male connector contacts with the key removed from the cylinder (figure 57). If continuity exists, the fault is in the column.

STEERING COLUMN TROUBLE DIAGNOSIS (Cont'd.)

Condition	Possible Cause	Correction
Buzzer continues to operate with key out, but stops when door is closed.	<p>A. Turn lock towards "start" position if buzzer stops in "run" position or when turned past "run" towards "start", the problem is a sticky lock cylinder actuator.</p> <p>B. Chips, foreign material in lock cylinder bore.</p> <p>C. Sticky lock cylinder actuator tip.</p> <p>D. Damaged or broken buzzer switch.</p> <p>E. Buzzer switch contact gap too close.</p>	<p>A. Replace lock cylinder.</p> <p>B. Remove, reassemble and recheck function.</p> <p>C. Replace lock cylinder.</p> <p>D. Replace buzzer switch.</p> <p>E. Adjust as specified.</p>

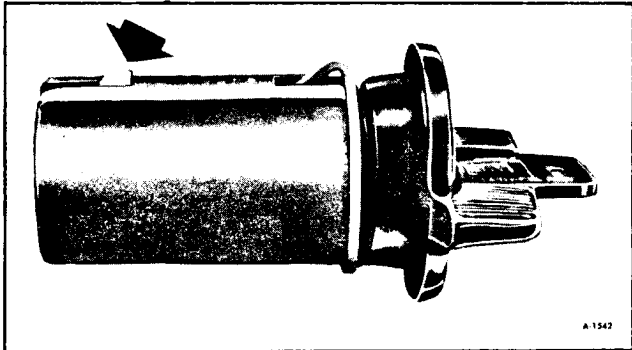

Figure 60-Actuator Extended

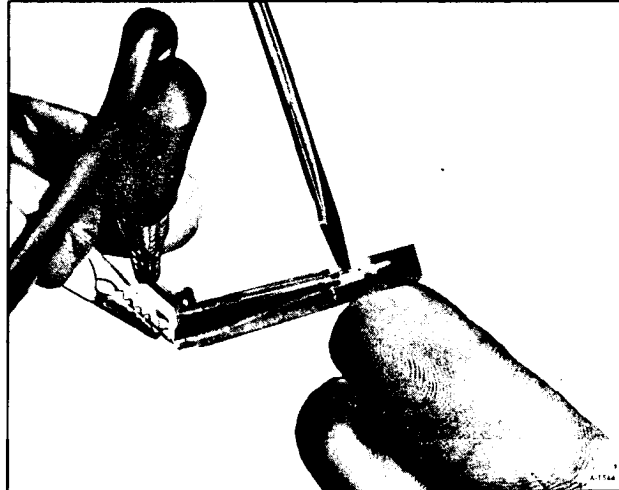

Figure 62-Checking Buzzer Switch Continuity

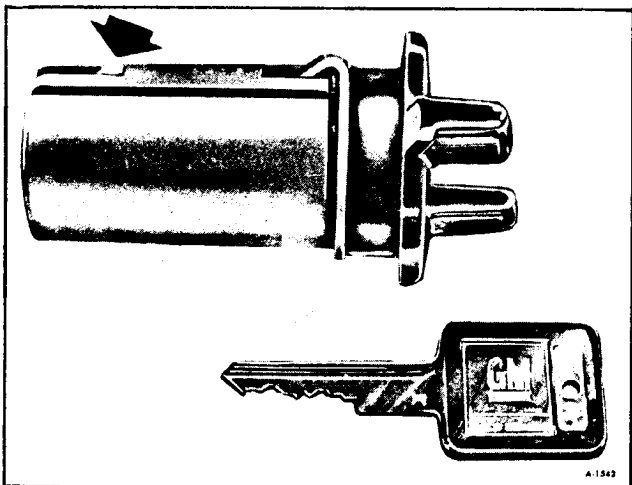

Figure 61-Acutator Retracted

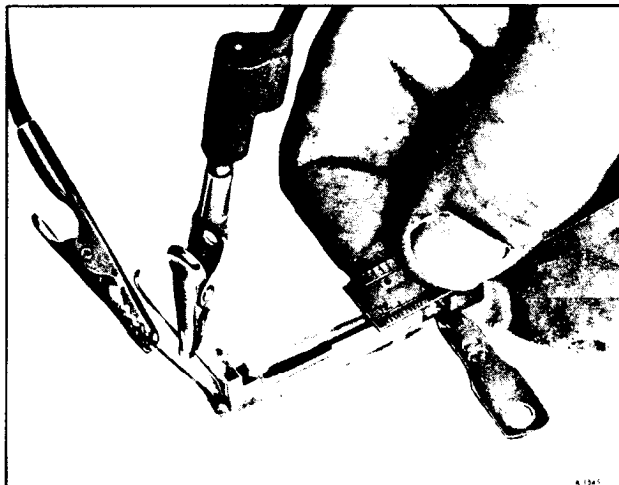

Figure 63-Checking Contact Gap



Figure 64—Adjusting Buzzer Switch

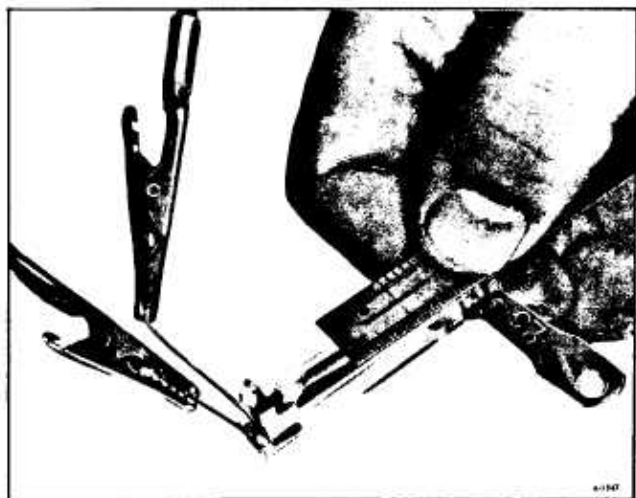

Figure 65—Checking Contact Gap

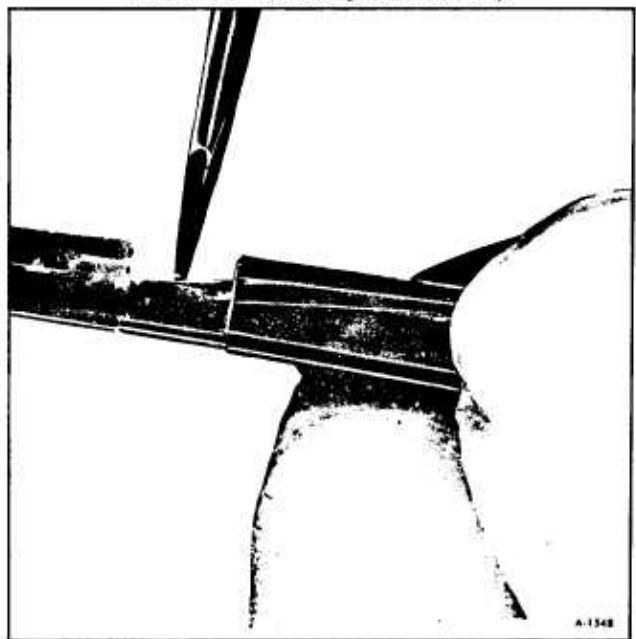

Figure 66—Adjusting Buzzer Switch

REMOVAL OF STEERING COLUMN

(Standard and Tilt)

NOTE: Once the steering column is removed from the vehicle, the column is extremely susceptible to damage. Dropping the column assembly on its end could collapse the steering shaft or loosen the plastic injections which maintain column rigidity. Leaning on the column assembly could cause the jacket to bend or deform. Any of the above damage could impair the column's collapsible design. If it is necessary to remove the steering wheel, use standard wheel puller. Under no conditions should the end of the shaft be hammered upon as hammering could loosen plastic injections which maintain column rigidity.

1. Disconnect column from lower steering shaft at cinch clamp.
2. Disconnect the shift linkage from the shift lever.
3. Remove screws securing toe pan cover to firewall and loosen cover.
4. Remove bolts securing bracket to instrument panel and disconnect "PARK RNDSL" pointer on the automatic shift column.
5. Disconnect all electrical connectors from the steering column assembly. Carefully withdraw column.

STANDARD COLUMN OVERHAUL (FIGURE 67)

NOTE: All elements of energy-absorbing columns are sensitive to damage and must be handled with care.

DISASSEMBLY—UPPER END

Steps "1" through "12" can be performed in or out of the vehicle.

IMPORTANT: Make sure column is not bent during removal from vehicle.

1. Remove steering wheel using standard wheel puller. **DO NOT HAMMER ON END OF STEERING SHAFT.**

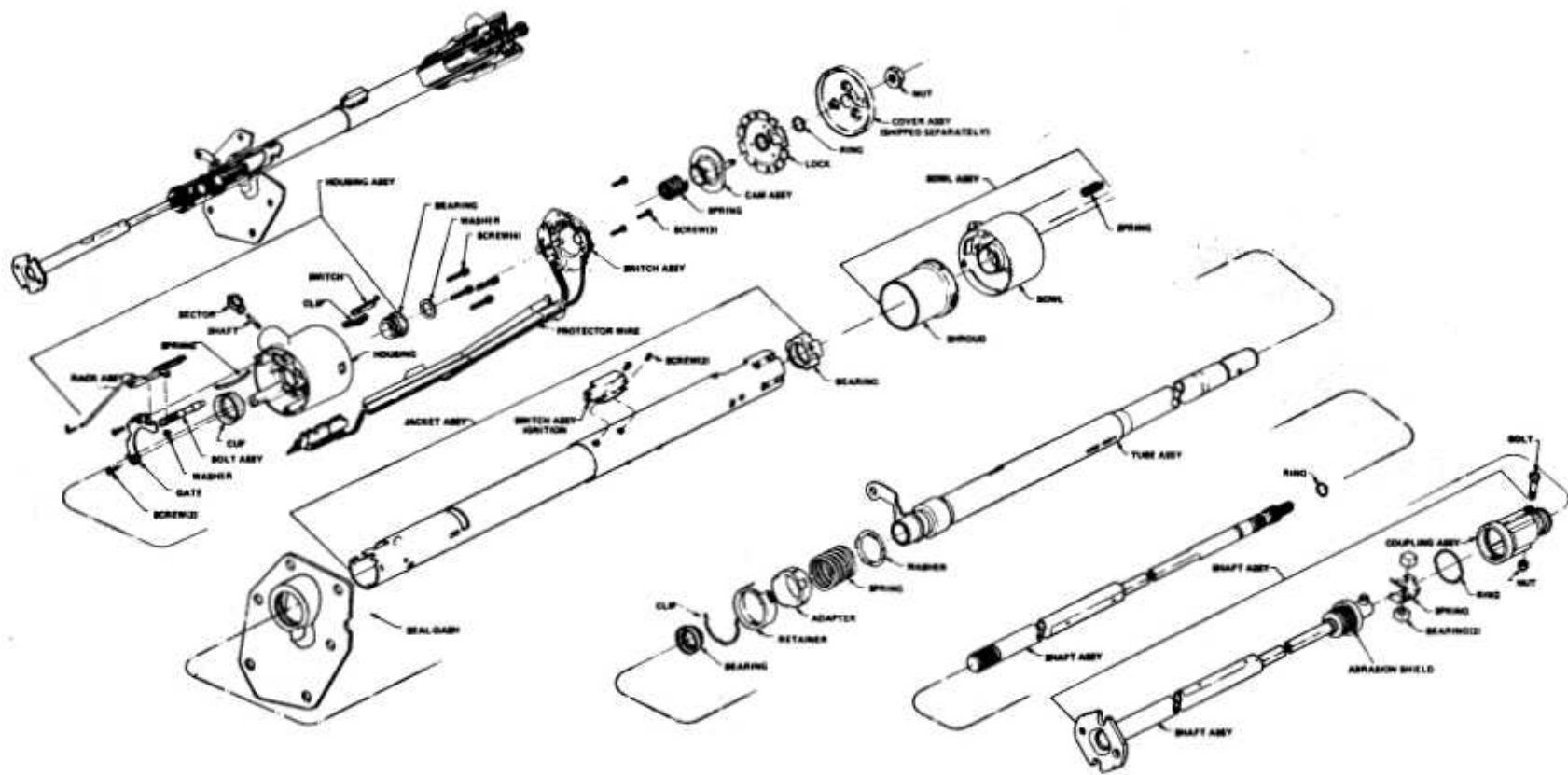

A-1549

Figure 67-Standard Column

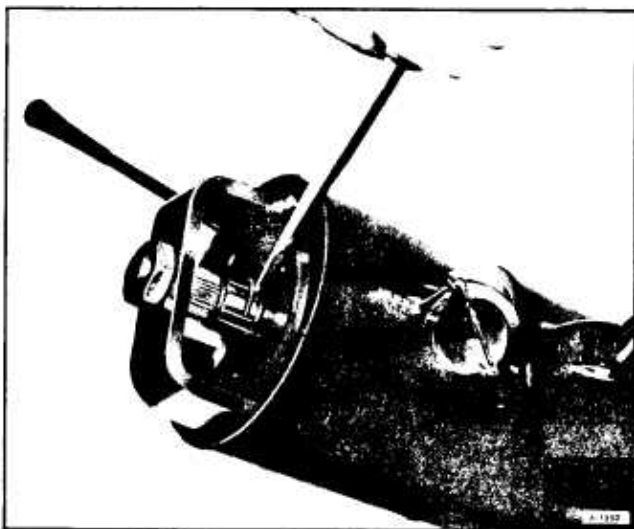

Figure 68—Removing Retaining Ring

2. Remove the three cover screws and lift cover off the shaft.

3. Depress lock plate downward as far as possible using special tool J-23131 or J-23653 and the hand wheel nut. Pry the retaining ring out of the shaft groove. (figure 68). Remove the retaining ring and lock plate. (figure 69).

CAUTION: *With ring removed, shaft could slide out bottom of column causing damage to shaft.*

4. Slide upper bearing preload spring and turn signal cancelling cam off upper steering shaft.

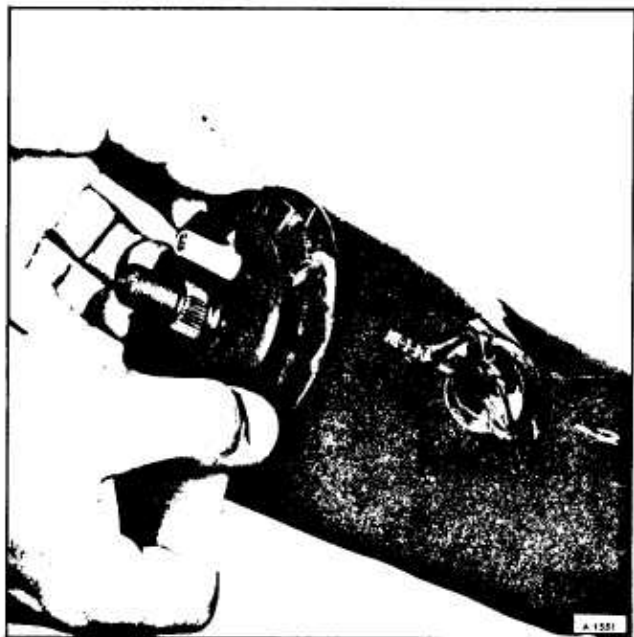

Figure 69—Removing Lock Plate

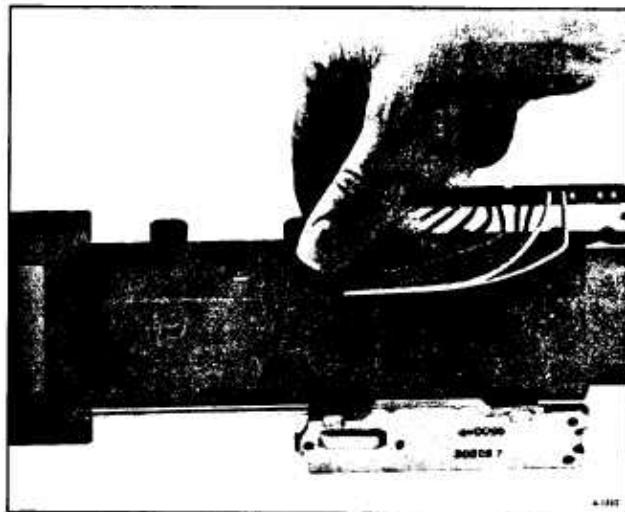

Figure 70—Removing Protector

5. Slide thrust washer off upper steering shaft.

6. Remove turn signal lever screw and lever.

7. Push hazard warning switch in and unscrew knob.

8. Remove three switch mounting screws. Remove the four mounting bracket screws and the bracket from the jacket. Pull the connector out of the bracket on the jacket. Remove the protector from the jacket and strip the wires from it. (figure 70).

9. Pull the switch straight up, being careful not to snag the signal switch wire connector in the housing. (figure 71).

10. The lock cylinder should be removed in the "run" position.

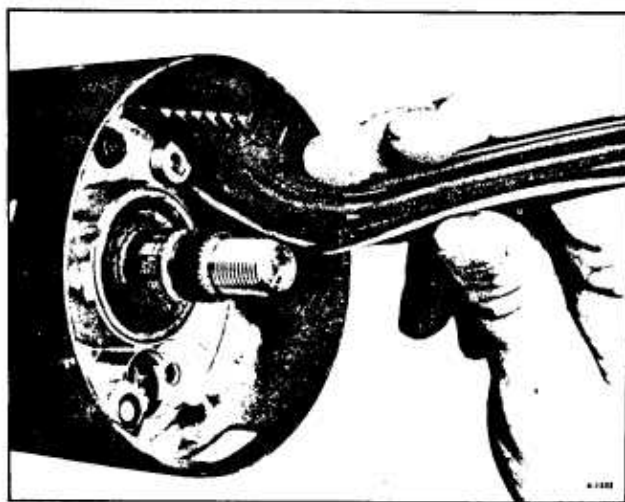

Figure 71—Removing Switch Assembly

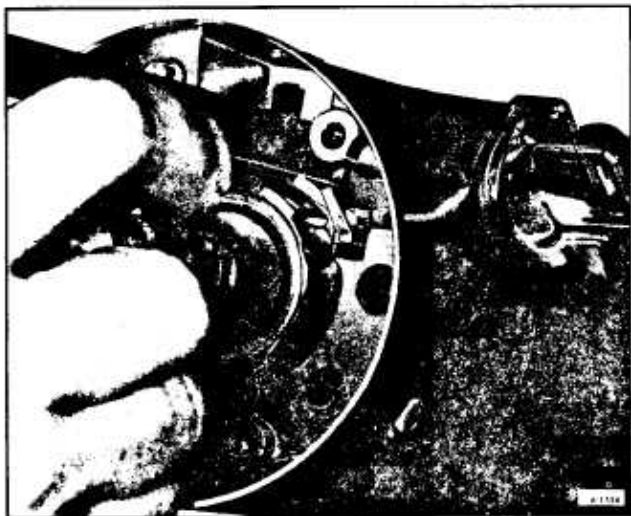

Figure 72—Removing Lock

11. Insert a thin tool (small screw driver or knife blade) into the slot next to the switch mounting screw boss (right-hand slot) and depress retainer at bottom of slot, which releases lock. Remove lock. (figure 72).

12. The buzzer switch can be pulled straight out of the housing. A flat spring wedges the switch toward the lock cylinder. (This may be done without the removal of the lock cylinder. If the lock cylinder is in the housing, it must be in the "run" position.) (figure 73).

If service is required on the upper end only, steps 1 through 12 can be performed in the vehicle.

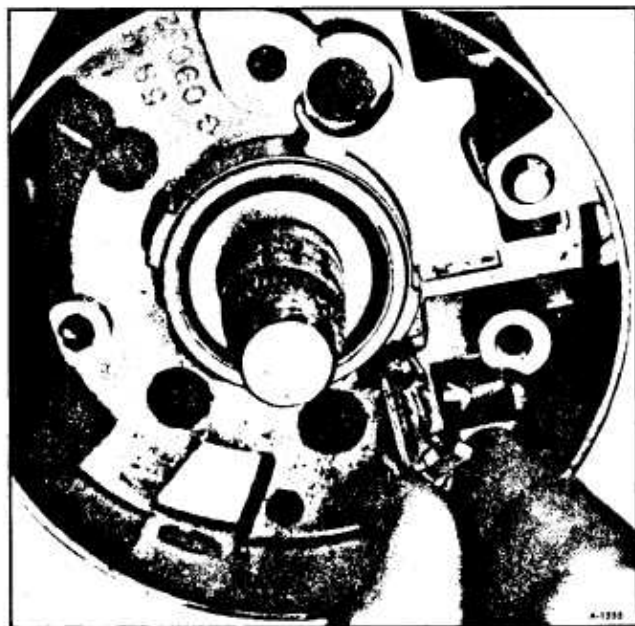

Figure 73—Removing Buzzer Switch

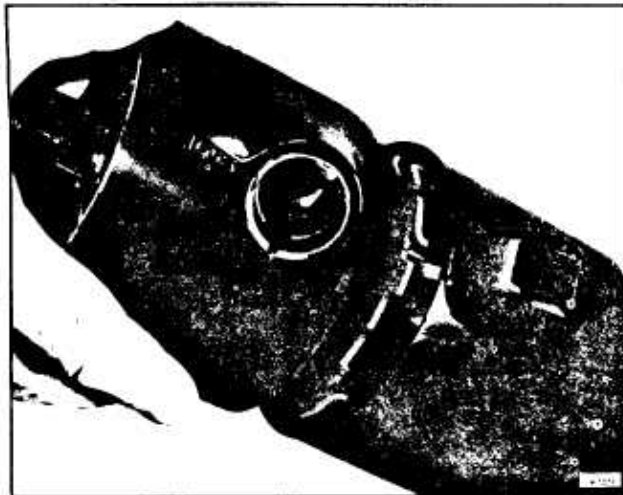

Figure 74—Removing Upper Housing Assembly

13. To remove any further parts from the upper end, the ignition switch should be removed. The switch should be positioned in "off-unlocked" position before removing. If the lock cylinder has already been removed, the connecting rods to the switch should be pulled up to a definite stop and then moved down two detents, which is the "off-unlocked" position. Now remove the two attaching screws and the switch.

14. Drive out shift lever pivot pin and remove shift lever.

15. Remove the four screws attaching the upper housing to the jacket. Remove the upper housing assembly. (figure 74).

16. Remove thrust cup. (figure 75).

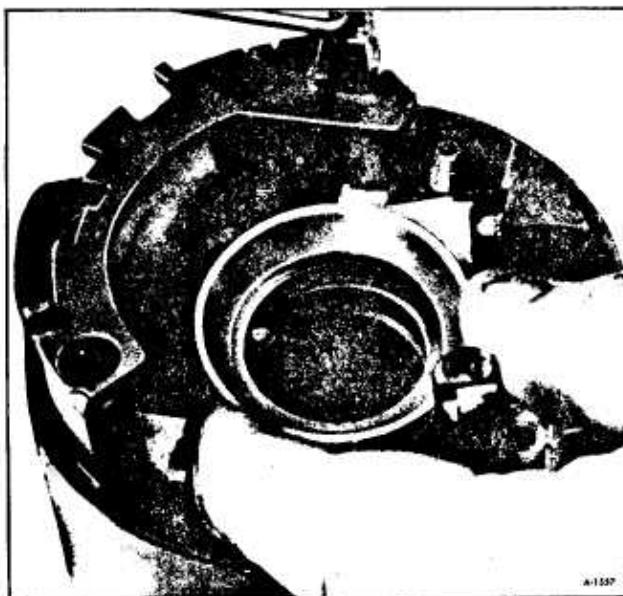

Figure 75—Removing Thrust Cup

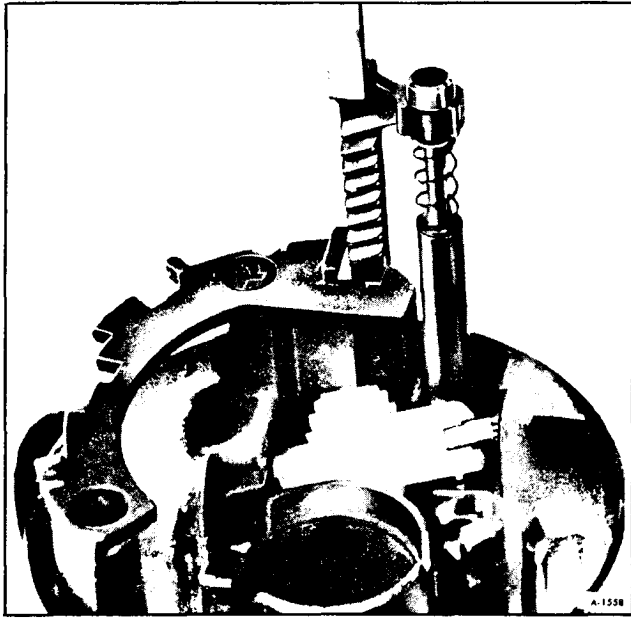

Figure 76-Removing Rack and Lock Bolt

17. Remove the rack and lock bolt. (figure 76).
18. Remove rack preload spring. (figure 77).
19. Remove the shift gate. (figure 78).

20. Remove the sector through the lock cylinder hole by pushing firmly on the block tooth of the sector with a blunt punch. (figure 79).

21. Remove shift bowl and shroud from the jacket.

22. Remove lower bowl bearing from top of jacket. (figure 80).

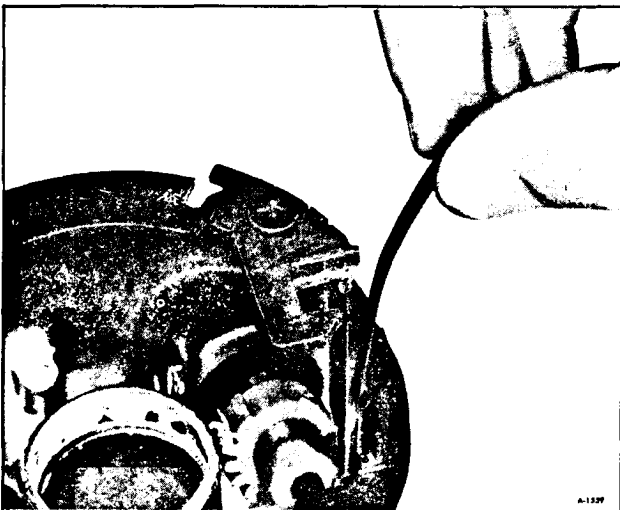

Figure 77-Removing Rack Preload Spring

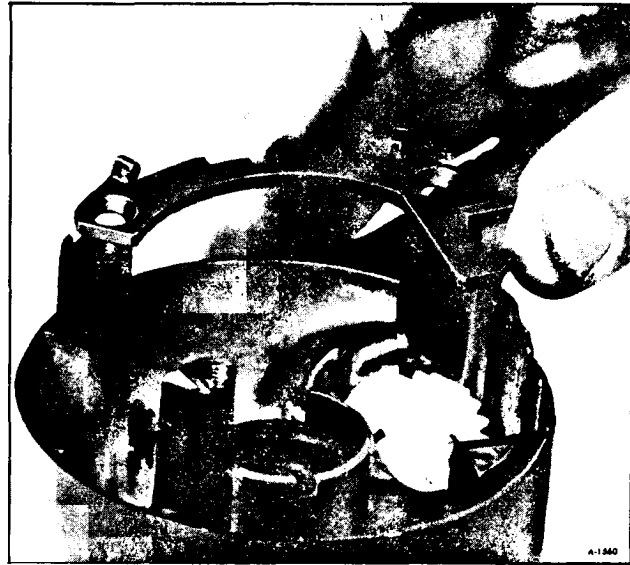

Figure 78-Removing Shift Gate

DISASSEMBLY OF LOWER END

Steering wheel, cover, lock plate, retaining ring, spring, cancelling cam and flat washer must be removed prior to disassembly of the lower end. Follow instructions above.

1. Pull steering shaft assembly from bottom of column.
2. Remove the two screws holding the neutral-start switch and remove switch. (figure 81).
3. Remove bearing adapter clip. (figure 82).

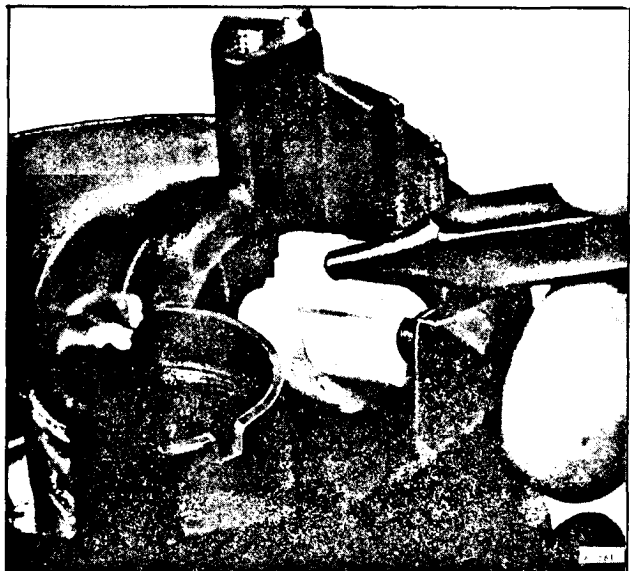

Figure 79-Removing Sector



Figure 80—Removing Lower Bowl Bearing

4. Remove bearing retainer, bearing adapter, and shift tube spring. (figure 83). (Bearing may be removed from adapter by a light press-out operation on the outer race).

5. Slide out shift tube assembly.

REASSEMBLY OF UPPER END

Apply a thin coat of lithium soap grease to all friction surfaces.

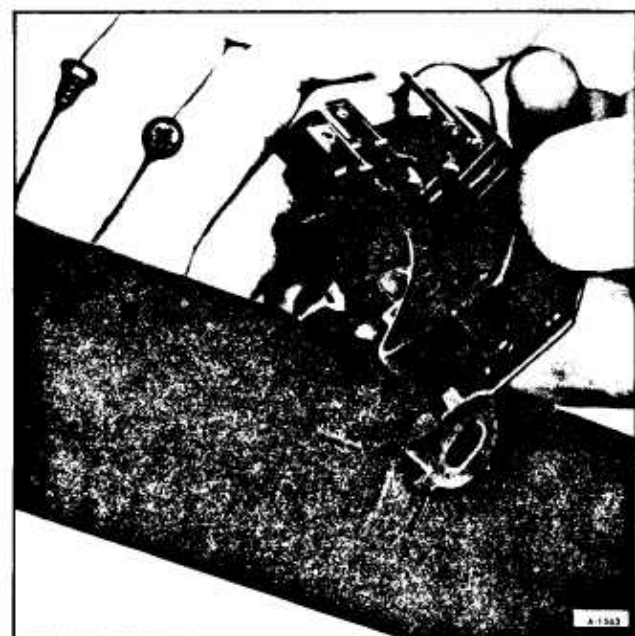

Figure 81—Removing Neutral Start Switch



Figure 82—Removing Bearing Adapter Clip

1. Install the sector in the lock cylinder hole over the sector shaft with the tang end to the outside of the hole. Press the sector over the pin with a blunt tool. (figure 84).

2. Install the shift gate to the housing (45 in-lbs).

3. Insert the rack preload spring in the housing from the bottom side. (figure 77).

4. Assemble the bolt to the cross-over arm of the rack. (figure 85).



Figure 83—Removing Bearing Adapter and Shift Tube Spring



Figure 84—Installing Sector

5. Insert the rack and lock bolt into the housing from the bottom with the teeth up (toward hand-wheel) and toward the centerline of the column. (figure 86).

6. Install the thrust cup on the bottom hub of the housing. (figure 75).

7. Install lower bowl bearing in jacket. (figure 80).

8. Install bowl and rotate it to be sure it is seated in bearing.

9. With the bowl in place, install the upper bearing housing assembly on the jacket.

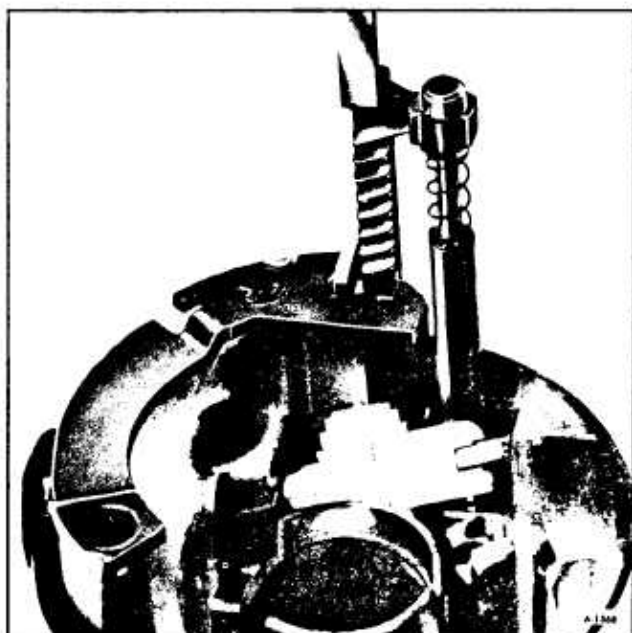

Figure 86—Installing Rack and Lock Bolt

The bowl should be in the "park" position and the rack pulled downward. Be sure the housing is seated on the jacket and drive the screws. (60 in-lbs). (figure 87).

10. Assemble buzzer switch to spring clip with formed end of clip around the lower end of switch and spring bowed away from switch. This should lay on the switch opposite the contacts. Push switch and spring into hole with the internal switch contacts toward the lock cylinder bore. (figure 73).

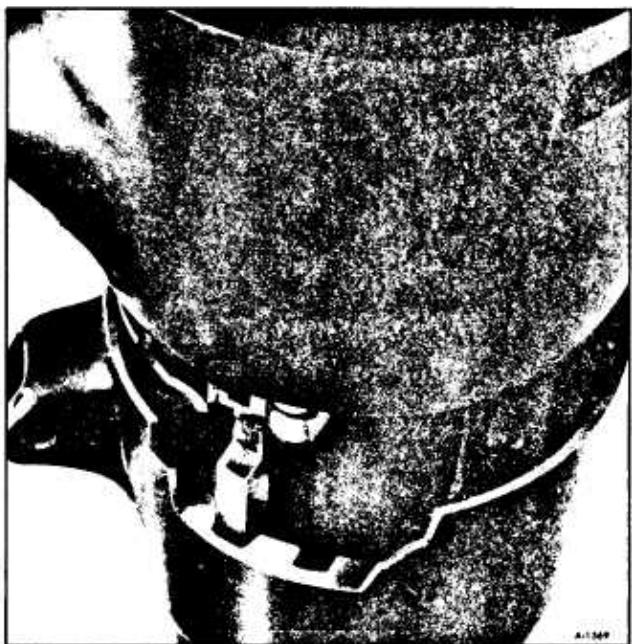

Figure 87—Installing Upper Bearing Housing Assembly

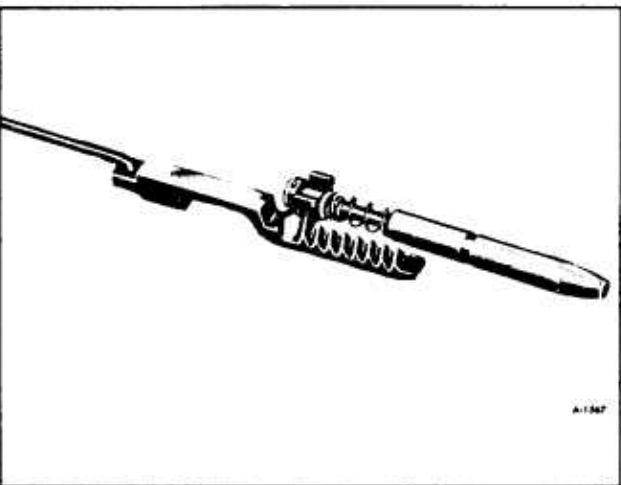

Figure 85—Bolt and Rack Assembly

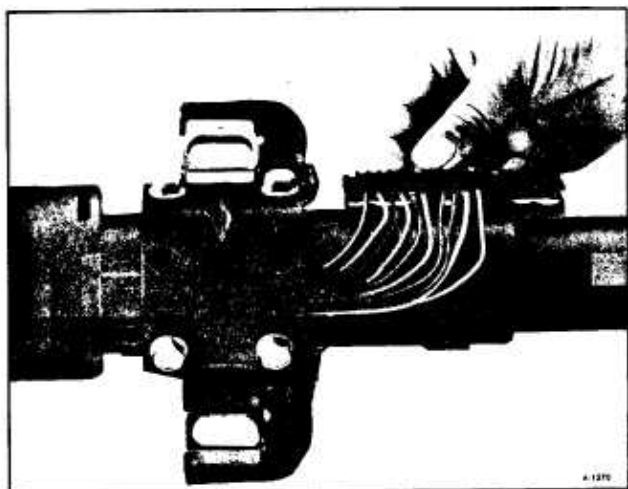

Figure 88—Clipping Connector To Jacket Bracket

11. Replace the turn signal switch. Feed the connector (bend wires as shown in figure 71) down through the housing. Assemble the wires into the protector and the protector to the jacket. Hold I.P. bracket in place and drive four screws. Clip connector into bracket on jacket. (figure 88).

12. To install lock, hold lock cylinder sleeve and rotate knob clockwise against stop. Insert cylinder into housing bore with key on cylinder sleeve aligned to keyway in housing, push in to abutment of cylinder and sector. Rotate knob counterclockwise, maintaining a light push inward on cylinder, until drive section of cylinder mates with sector. Push in until retainer pops into grooves and lock cylinder is secured in housing. Check freedom of rotation.

13. When replacing the ignition switch, place the shift bowl in any position except "Park" and rotate lock counterclockwise until the rack bottoms against the lower surface of the cast in bowl plate. Place the ignition switch in the "off-unlocked" position by the following procedure.

Position switch as shown in Figure 89.

Move the slider to the extreme left. (Accessory).

Move the slider 2 positions to the right from "accessory" to the "off-unlock" position.

Fit the actuator rod into the slider hole and assemble to the column with two screws. Caution should be exercised to prevent moving the switch out of detent. Use only the correct screws. Tighten to 35 in-lbs.

14. Assemble washer, spring and cancelling cam on shaft, making certain that the turn signal switch is in "neutral" and the hazard warning plunger is

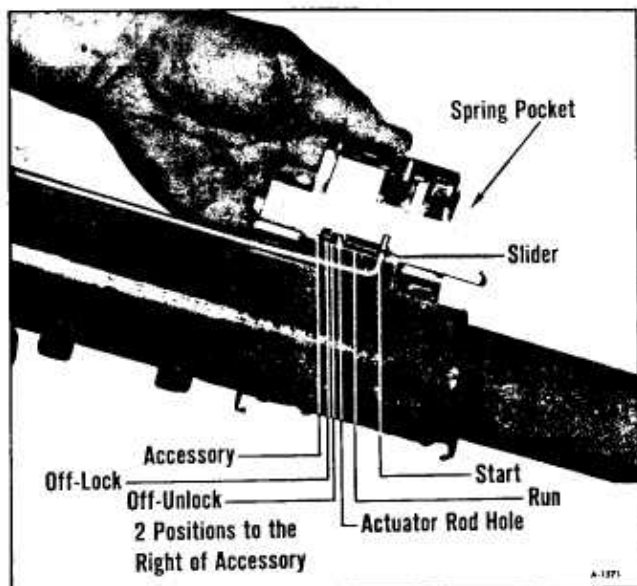

Figure 89—Positioning Ignition Switch

out. Assemble the lock plate on the shaft, depress these parts and install a new retaining ring in groove on shaft. The switch assembly may be damaged if the above procedure is not followed.

15. Place cover on shaft lock and drive screws. (15in-lbs).

16. Assemble steering wheel and levers. Be sure bowl is in "Drive" when inserting shift lever.

REASSEMBLY OF LOWER END

Apply a thin coat of lithium soap grease to all friction surfaces.

1. Press the lower bearing assembly into adapter assembly. (if removed).

2. Insert the shift tube assembly into the lower end of the jacket and rotate until the upper shift tube key slides into the bowl keyway.

3. Assemble the spring adapter assembly and retainer into the bottom of the jacket. Holding the adapter in place, insert the snap ring into the jacket and mating retainer slots.

4. Install the neutral-start switch, making certain the proper screws are used. (figure 81). (15 in-lbs)

5. Slide steering shaft assembly into column. (The upper housing should be in place before the shaft is assembled.)

TILT COLUMN OVERHAUL

DISASSEMBLY OF STEERING COLUMN

1. Disconnect column from lower steering shaft at cinch clamp.

2. Remove column mounting bracket from column and **SET ASIDE TO PROTECT BREAKAWAY CAPSULES.**

3. Mount assembly in vise using tool No. J-23074.

4. Remove steering wheel using wheel puller. **DO NOT HAMMER ON END OF STEERING SHAFT.**

5. Remove signal switch wire protector. **DO NOT DAMAGE WIRES.** (figure 90). Wrap a piece of tape around the upper connector and wires to prevent snagging when removing the switch. (figure 91)

6. Remove three cover screws. Remove shaft lock cover.

7. Remove tilt release lever, signal switch lever, push hazard warning plunger in and remove hazard warning knob. Remove upper shift lever from bowl. Remove indicator wire, if automatic transmission column. Remove neutral start switch.

8. Depress lock plate with finger and pry retaining ring out of groove with screw driver (figure 92).

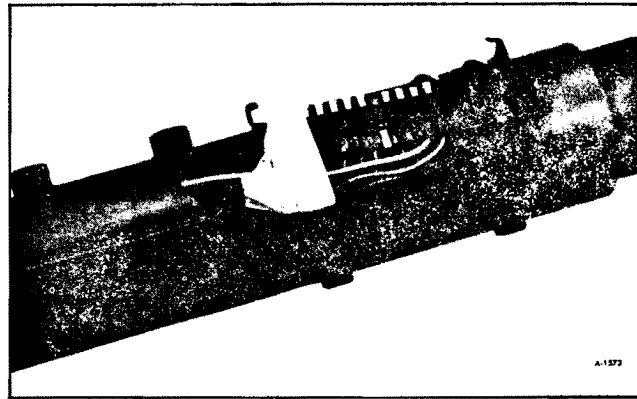

Figure 91—Connector and Wires Taped

Tool J-23653 can be used (figure 93) but the full load of the upper bearing spring should not be relieved as then the retaining ring will turn easily making removal more difficult. Remove lock plate, cancelling cam and upper bearing spring.

9. Remove the three signal switch mounting screws.

10. Position shift bowl in "low" shift position. Pull the switch straight up (figure 94).

11. The lock cylinder should be removed in the "Run" position.

12. Insert a thin tool (small screw driver or knife blade) into the slot next to the switch mounting screw boss (right-hand slot) and depress retainer at



Figure 90—Removing Wire Protector

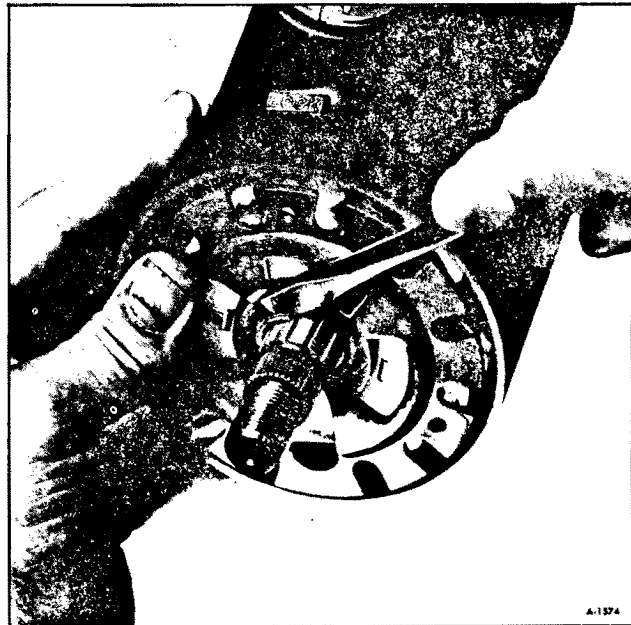

Figure 92—Removing Retaining Ring



Figure 93—Using Tool to Remove Retaining Ring

bottom of slot, which releases lock. Remove lock (figure 95).

13. The buzzer switch can be pulled straight out of the housing (figure 96). A flat spring wedges the switch toward the lock cylinder (figure 97).

14. Remove three housing cover screws and remove housing cover.

15. Reinstall tilt release lever and place column

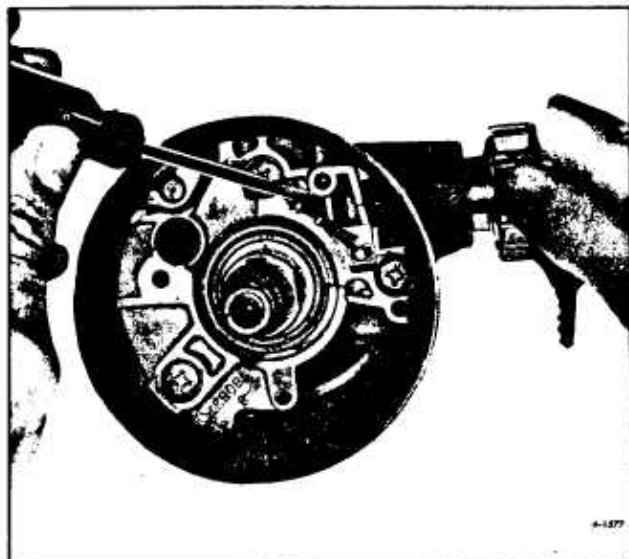

Figure 95—Removing Lock

in full tilt "up" position. Remove tilt spring retainer using screw driver blade that just fits into slot opening. Insert screw driver in slot, press in approximately 3/16 in., turn approximately 1/8 turn counter-clockwise until ears align with grooves in housing and remove spring and guide (figure 98).

16. With the ignition switch in "acc" position, remove two ignition switch mounting screws and ignition switch. Remove two neutral-start switch screws and neutral-start switch.

17. Remove two pivot pins with tool No. J-21854-1 (figure 99). Remove intermediate shaft as-

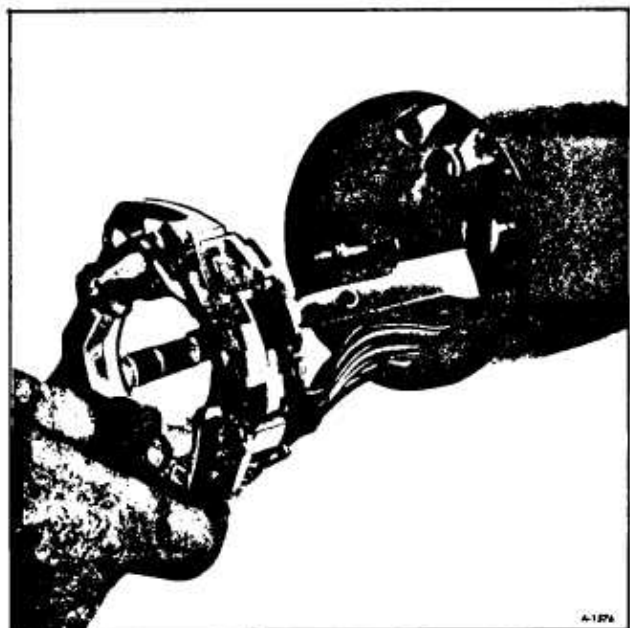

Figure 94—Removing Signal Switch



Figure 96—Removing Buzzer Switch



Figure 97—Buzzer Switch and Spring Retainer

sembly or lower flange so shaft can be pulled up through column.

18. Disengage lock shoes by pulling on release lever. Remove bearing housing assembly by pulling upward to extend rack full down and moving housing assembly to the left to disengage rack from actuator. Remove actuator rod assembly.

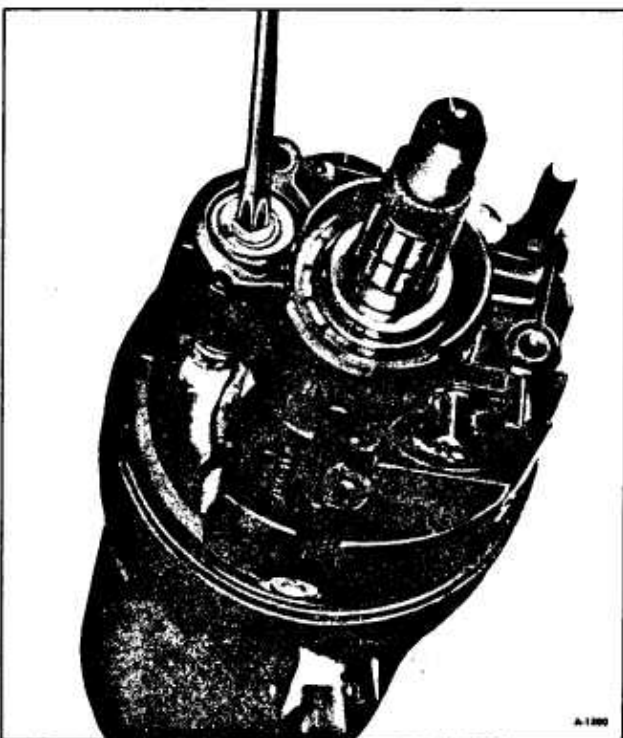

Figure 98—Removing Tilt Spring Retainer



Figure 99—Removing Pivot Pins

19. Remove steering shaft assembly. Remove upper bearing seat and inner race.

20. Disassemble steering shaft assembly by removing center spheres and anti-lash spring.

21. Remove four support screws and remove support assembly.

22. Remove shift tube retaining ring with screw driver. Remove thrust washer.

If service is required on upper end only, steps 1 thru 22 may be performed in the vehicle. It is necessary to remove the mounting bracket and loosen toe plate to prevent bending of jacket and toe plate to service the signal switch.

23. Remove clip, bearing adapter retainer and bearing adapter assembly from lower end of jacket.

24. Remove shift tube from bowl (use tool No. J-23072) (figure 100). Insert bushing on end of tool in shift tube and force tube out of bowl. Care should be taken not to jam lower shift lever into lower jacket. Lever must be aligned with "T" slot to remove shift tube. **DO NOT HAMMER OR PULL ON LOWER OR UPPER SHIFT TUBE BECAUSE PLASTIC JOINT MAY BE SHEARED.**

25. Remove shift tube assembly from jacket from lower end.

26. Remove lock plate by sliding out of jacket notches and tipping down toward bowl hub at 12

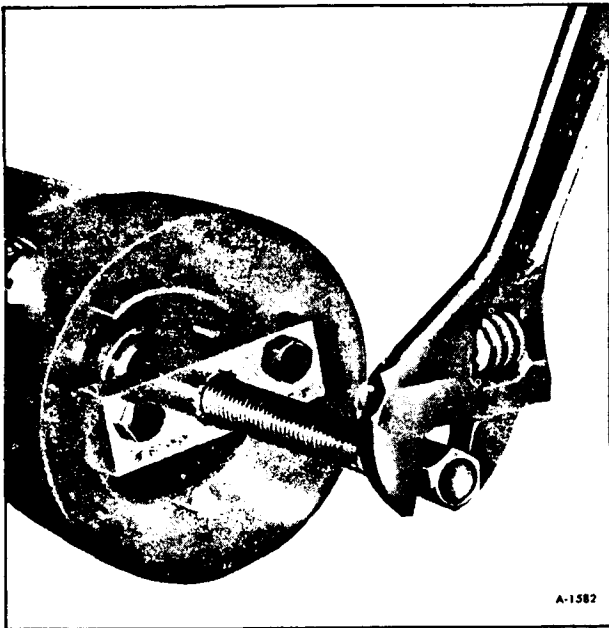

Figure 100—Removing Shift Tube From Bowl



Figure 102—Removing Lock Bolt Spring

o'clock position and under jacket opening. Remove wave washer.

27. Remove bowl from jacket. Remove shift lever spring from bowl by winding spring up with pliers and pulling out.

28. Remove tilt lever opening shield from housing (figure 101).

29. Remove lock bolt spring by removing spring retaining screw and moving spring clockwise to remove from bolt (figure 102).

30. If there is a snap ring, remove it from sector drive shaft. With small punch lightly tap drive shaft from sector (figure 103). Remove drive shaft. Remove rack and rack spring (also shim, if there is one). Remove sector and bolt.

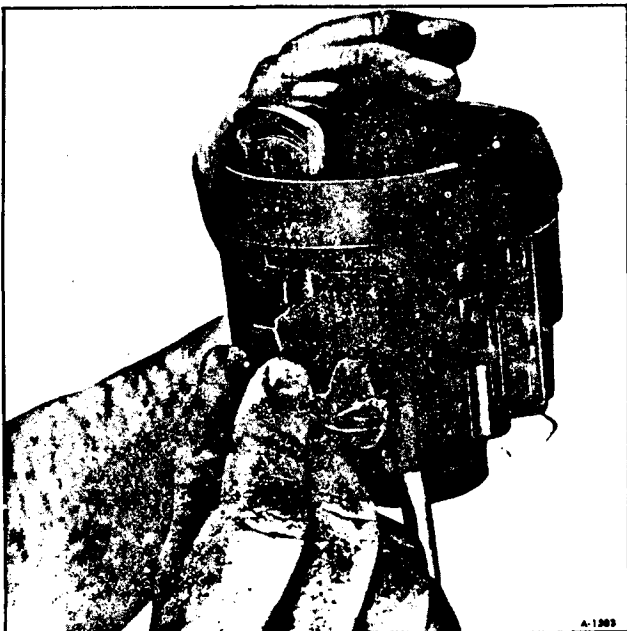

Figure 101—Removing Tilt Lever Shield

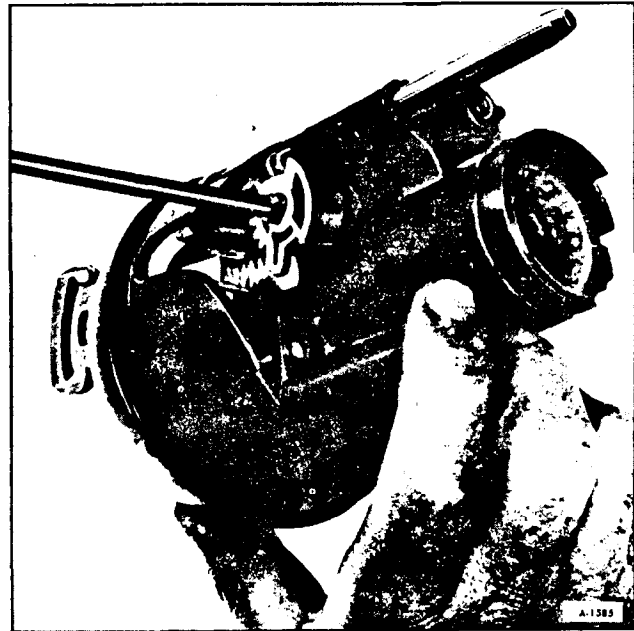

Figure 103—Removing Drive Shaft

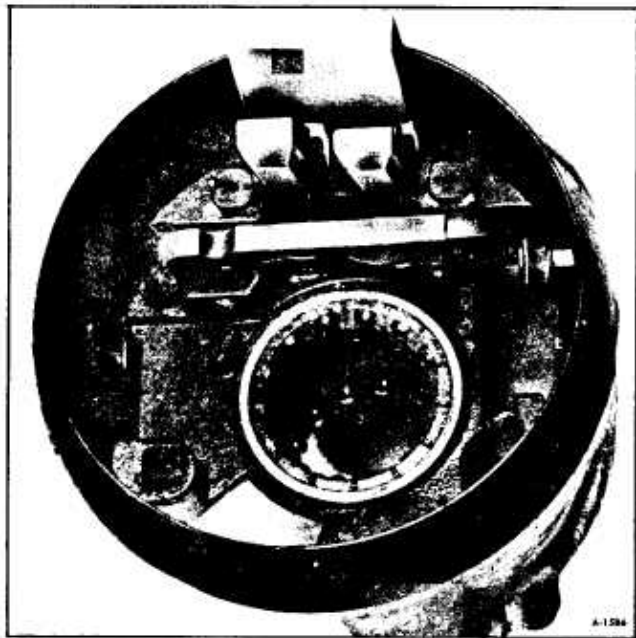

Figure 104—Removing Load on Release Lever

31. Remove tilt release lever pin with pin punch and hammer. Remove lever and release lever spring. (To relieve load on release lever, hold shoes inward and wedge block between top of shoes (over slots and bearing housing) (figure 104).

32. Remove lock shoe pin with punch and hammer. Remove lock shoes and lock shoe springs.

33. Remove bearings from bearing housing only if they are to be replaced. Remove separator and balls from bearing. Place housing on work surface. With a pointed punch against back surface of race, carefully hammer race out of housing until bearing puller can be used. Repeat for other race. Do not re-use bearings.

ASSEMBLY OF STEERING COLUMN

Apply thin coat of lithium grease to all wear surfaces except lock, bolt and lock bolt hole.

1. Install new bearings in bearing housing, if removed.

2. Install lock shoe springs, lock shoe and shoe pin in bearing housing. Use approximately .180 rod to line up shoes for pin installation.

3. Install spring, release lever and pin in bearing housing. (Again, relieve load on release lever as in step 31 of "Disassembly of Steering Column").

4. Install drive shaft in housing. Lightly tap sector onto the shaft far enough to expose snap ring groove. Replace snap ring if it was removed.

5. Install lock bolt and engage with sector cam surface (figure 102).

6. Install rack and spring. (Replace shim if one was removed). Block tooth on rack to engage block tooth on sector (figure 102). Install external tilt release lever.

7. Install bolt spring and spring retaining screw. Tighten to 35 inch-pounds.

8. Install shift lever spring in bowl by winding up with pliers and pushing in. Slide bowl into jacket.

9. Install wave washer and lock plate into place. Work lock plate into notches in jacket by tipping lock plate toward bowl hub at 12 o'clock position and under jacket opening. Slide lock plate into notches in jacket.

10. Carefully install shift tube in lower end of jacket. Align key in tube with keyway in bowl and use tool No. J-23073 to pull shift tube into bowl (figure 105).

CAUTION: DO NOT PUSH OR TAP ON END OF SHIFT TUBE. Install thrust washer and retaining ring by pulling bowl up to compress wave washer.

11. Install support by aligning "V" in support



Figure 105—Installing Shift Tube

with "V" notch in jacket. Insert screws through support in lock plate. Tighten screws to 60 inch-pounds torque.

12. Align lower bearing adapter notches in jacket and push in lower end of jacket. Shift tube should pilot in adapter while this is done. Install adapter retainer and clip.

13. Install centering spheres and anti-lash spring in upper steering shaft. Install lower steering shaft from same side of spheres that spring ends protrude.

14. Install steering shaft assembly in shift tube from upper end. Carefully guide shaft through shift tube and bearing.

15. Install ignition switch actuator rod through bowl from bottom and insert in slot in support. Extend rack downward from bearing housing. Assemble bearing housing over steering shaft and engage rack over end of actuator rod (figure 106).

16. Holding lock shoes in disengaged position, assemble bearing housing over steering shaft until the pivot pin holes line up with the holes in the support.

17. Install pivot pins—assemble as far as possible using palm pressure of hand to prevent broaching of support pivot hole. Once started, tap home with a small hammer and punch.

18. Place housing in full "up" position, install guide, make sure there is grease between the guide and peg on support, tilt spring and tilt spring retainer, using screw driver in retainer slot. Turn retainer clockwise to engage (figure 98).

19. Install tilt lever opening shield in housing (figure 101).



Figure 106—Engaging Rack

20. Remove tilt release lever, install housing cover and seat screw at 12 o'clock position first. Tighten to 100 inch-pounds, 3 screws.

21. Assemble buzzer switch to spring clip with formed end of clip under end of switch and spring bowed away from switch on side opposite contact (figure 97). Push switch and spring into hole in cover to the step with the contacts toward lock cylinder bore.

22. Install signal switch wires and connector through cover, bearing housing and bowl. Push hazard warning knob in, install switch and tighten screws to 25 inch-pounds.

23. Install wave washer (if one is used) and lower steering shaft flange or intermediate shaft assembly. Tighten pinch bolt to specified torque.

24. Install hazard warning knob and pull knob out. Install bearing inner race, seat, bearing preload spring, cancelling cam and lock plate.

25. Depress lock plate and install new retaining ring using tool J-23653 (figure 107).

26. Reinstall tilt release lever, signal switch lever (15 inch-pounds) and hazard warning knob (5 inch-pounds). Install upper shift lever and drive in pivot pin.

27. To install lock, hold lock cylinder sleeve and rotate knob clockwise against stop. Insert cylinder into cover bore with key on cylinder sleeve aligned to keyway in housing. Push in to abutment of cylin-



Figure 107—Installing Retaining Spring

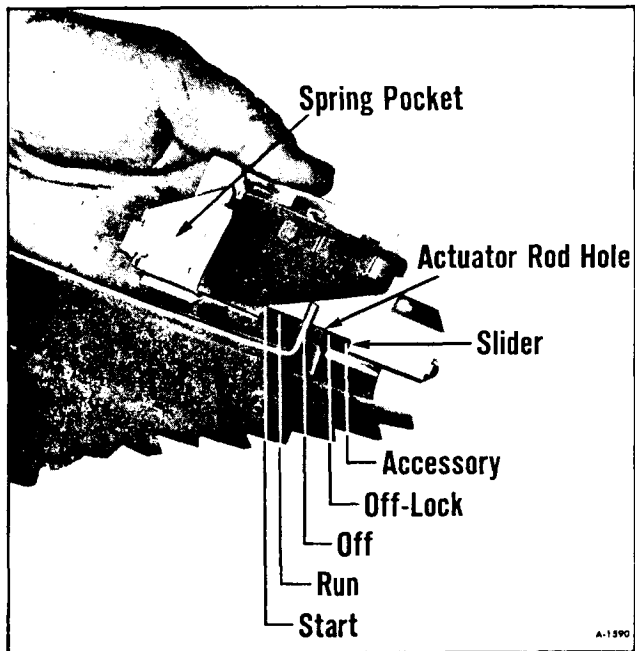

Figure 108—Installing Ignition Switch

der and sector. Rotate knob counterclockwise, maintaining a light push inward on cylinder, until drive section of cylinder mates with drive shaft. Push in until retainer pops into groove. This locks cylinder into cover. Check freedom of rotation.

28. Install shaft lock cover and tighten three screws to 15 inch-pounds.

29. When replacing ignition switch, place the lock in "Acc" position. Place the switch in "acc" by the following procedure:

A. Position the switch as it is shown in Figure 108.

B. Move the slider to the extreme right, to the "acc" position.

Fit the actuator rod into the slider hole and assemble to the column with two screws. Lightly push the switch down the column (away from the steering wheel), to take out lash in the actuator rod, and tighten mounting screws. Caution should be exercised to prevent moving the switch out of detent. Use only the correct screws. Tighten to 35 inch-pounds.

30. Install neutral-start switch and back-up light switch. Do not tighten screws. Neutral-start switch will be adjusted in the car and should be tightened to 20 inch-pounds. **DO NOT SUBSTITUTE SCREWS.**

31. Install lower wire protector over wires and on jacket (figure 90).

32. Install mounting bracket. **DO NOT SUBSTITUTE BOLTS.** (Mounting bracket torque, 15 foot-pounds).

33. Install steering wheel. Torque steering wheel nut to 30 foot-pounds.

34. Install horn parts.

STEERING COLUMN INSTALLATION (ALL COLUMNS)

Make sure this procedure is followed in exactly this order.

1. Reconnect all electrical connections.

2. Install column into position and loosely attach mounting bracket to instrument panel with two mounting bolts.

CAUTION: *Do not use longer bolts or over-torque bolts. The correct bolts and torque are necessary to insure the breakaway action of the bracket and capsules in the event of a collision.*

3. Attach column at coupling. Tighten fasteners to specified torque.

4. Attach column bolts to instrument panel with specified torque.

5. Slide dash mounting plate firmly against dash and install mounting screws.

CAUTION: *Make certain that column instrument mounting panel is never unsupported when either dash mounting or gear mounting is connected.*

TORQUE SPECIFICATIONS

STEERING LINKAGE

Part	Location	Torque (Ft. Lbs.)
Nut	Steering Arm to Tie Rod End	40-50
Nut	Tie Rod Clamp Nuts	19-24
Nut	Tie Rod To Intermediate Rod	40-50
Nut	Idler Arm To Intermediate Rod	40-50
Nut	Idler Arm To Frame	85-110
Nut	Relay Lever To Intermediate Rod	40-60
Bolt	Relay Lever To Frame	250-300
Nut	Drag Link To Relay Lever	40-60
Nut	Drag Link To Pitman Arm	40-60
Nut	Pitman Arm To Steering Gear	160-210

POWER STEERING PUMP

Part	Torque (Ft. Lb.)
Pulley Nut	45-65
Pump Mounting Bolts.....	25-30
Reservoir Bolt	25-30
Flow Control Fitting Assm.	35
Pressure Hose.....	35

STEERING GEAR

Part	Torque (Ft. Lb.)
Gear to Frame Bolts	70-80
High Pressure Line Fitting (At Gear).....	30
Oil Return Line Fitting (At Gear).....	30
Adjusting Screw Locknut	35
Side Cover Bolts	35
Adjuster Plug Locknut	80
Coupling Flange Nuts.....	20
Return Guide Clamp Screws	5
Rack-Piston Plug	75
Pitman Shaft Nut	160-210
Coupling Flange Bolt	30

STEERING COLUMN

Standard Column	Ft. Lb.
Pinch Bolt, to Steering Shaft	30
Pinch Bolt, demountable flange to Steering Gear	30
Bolt Nut, pot coupling clamp	50

Standard Column	In.-Lb.
Shift Gate Mounting Screws	45
Housing Screws.....	60
Signal Switch Mounting Screws.....	25
Ignition Switch Mounting Screws.....	35
Steering Shaft Lock Cover Screw.....	15
Neutral Start Switch Mounting Screws.....	15
Signal Switch Lever Screw	15
Bearing Screws (Synchro)	90
Hazard Warning Knob	5

Tilt Column	Ft. Lb.
Pinch Bolt, to Steering Shaft	30
Pinch Bolt, demountable flange to Steering Gear	30
Bolt Nut, pot coupling clamp	50

Tilt Column	In. Lb.
Spring Retaining Screw.....	35

	In. Lb.
Tilt Column	
Spring Retaining Screw.....	35
Support Screws.....	60
Housing Screws.....	100
Signal Switch Mounting Screws.....	25
Shaft Lock Cover Screws.....	15
Ignition Switch Mounting Screws.....	35
Neutral Start Mounting Switch Screws.....	20
Tilt Release Lever Screw.....	30
Hazard Warning Knob.....	5
Steering Wheel Nut.....	30
Signal Switch Lever Screw.....	15

SPECIAL TOOLS

J-23600	Belt Tension Gauge
J-1859-03	Steering Wheel Puller
J-5176-01	Checking Gauge
J-5860	Torque Wrench Adapter
J-6217	Connector Seat Installer
J-6219	Pitman Shaft Seal Installer
J-6222	Stub Shaft Seal Protector
J-6278-1	Pitman Shaft Bearing Remover
J-6278-2	Pitman Shaft Bearing Installer
J-7079-2	Handle
J-7576	Rack Piston Seal Compressor
J-7624	Spanner Wrench
J-7726	Seal Installer
J-7754	Torque Wrench
J-7786	Gauge Adapter
J-8058	Torque Wrench
J-8092	Handle
J-8524-1	Adjuster Plug Bearing Installer
J-8524-2	Adjuster Plug Bearing Remover
J-21552	Ball Retainer
J-21854-01	Pivot Pin Remover
J-22407	Pitman Shaft Bearing Installer
J-22616	Pump Shaft Seal Protector
J-23063	Spring Remover
J-23072	Shift Tube Remover
J-23073-01	Shift Tube Installer
J-23653	Lock Plate Compressor
J-24319	Ball Stud Puller

SECTION 10

WHEELS AND TIRES

Contents of this section are listed below:

SUBJECT	PAGE NO.
General Description.....	10-1
Tire Traction	10-1
Tread Wear	10-1
Maintenance.....	10-2
Wheel Studs	10-2
Freezing of Nut	10-2
Wheel Maintenance	10-2
Tire Rotation	10-2
Inflation of Tires	10-3
Wheel and Tire Balancing.....	10-3
Tire Replacement.....	10-4
Mounting	10-5
Demounting	10-7
Wheel and Tire Inspection	10-7
Wheel and Tire Wear	10-7
Wheel Inspection	10-8
Specifications	10-10

GENERAL DESCRIPTION

The factory installed tires on the Motor Home are designed to provide the best all-around performance for normal vehicle operation. They are tubeless type, 8.75-16.5, load range D, bias-ply polyester cord. Optional bias-ply steel belted tires are available. Only tires of this size and construction should be used as replacements. Replacement wheels should be equivalent to those removed in diameter, rim width and off-set.

TIRE TRACTION

A decrease in driving, cornering, and braking traction occurs when water, snow, ice, gravel, or other material is on the road surface. Driving practices and vehicle speed should be adjusted to the road conditions.

When driving on wet or slushy roads, it is possible for a wedge of water to build up between the tire and road surface. This phenomenon, known as hydroplaning, may cause partial or complete loss of traction, which adversely affects vehicle control and stopping ability. To reduce the possibility of traction loss, the following precautions should be observed:

1. Slow down during rain-storms or when roads are slushy.

2. Slow down if road has standing water or puddles.

3. Replace tires when tread wear indicators are visible.

4. Keep tires properly inflated.

TREAD WEAR (FIGURE 1)

The original equipment tires incorporate built-in tread wear indicators to assist in determining when tires have worn to the point of needing replacement. These indicators appear as 1/2-inch wide bands when tire tread depth is 1/16-inch or less. When the indicators appear in two or more adjacent grooves, tire replacement due to tread wear is recommended.

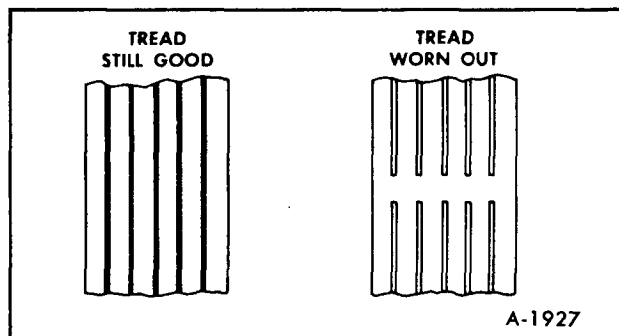

Figure 1-Tread Wear Indicators

MAINTENANCE

WHEEL STUDS

TIGHTENING WHEEL STUD NUTS

When Motor Home is new or after wheels have been replaced, check wheel stud nuts at 500 miles and after every wheel removal thereafter. Nuts should be tightened to 250 foot-pounds torque in sequence shown in Figure 2.

WARNING: IF ANY WHEEL EXPERIENCES A SINGLE STUD FAILURE CAUSED BY A LOOSE-RUNNING WHEEL, ALL WHEEL STUDS SHOULD BE REPLACED. A LOOSE-RUNNING WHEEL MAY CAUSE ONLY ONE STUD TO BREAK, BUT SEVERAL MORE STUDS MAY BECOME FATIGUED TO THE POINT OF FAILURE, BUT NOT ACTUALLY BREAKING. REPLACING ONLY THE BROKEN STUD AND REMOUNTING WHEEL WILL THEN SET THE STAGE FOR A SECOND AND POSSIBLY MORE SERIOUS FAILURE. IF HOLES IN THE WHEEL HAVE BECOME ELONGATED OR ENLARGED, REPLACE WHEEL.

Tighten wheel stud nuts as follows:

1. Install all nuts loosely, then finger-tighten only the nuts marked by arrows (figure 2).

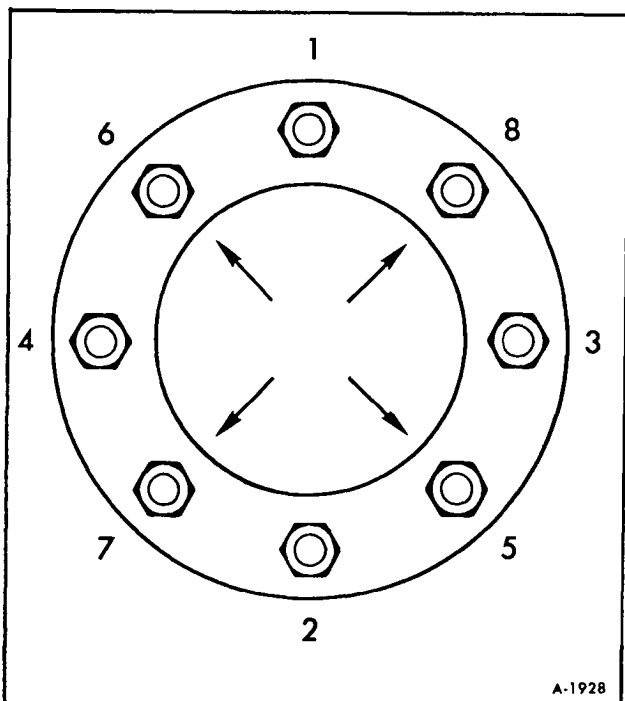

A-1928

Figure 2—Wheel Stud Tightening Sequence

2. Tighten all nuts to specified torque in sequence illustrated. Never use oil or grease on studs or nuts.

FREEZING OF NUT

Corrosion or galling of the stud and nut assembly can reach a point where removal of cap nuts is difficult. If this is a persistent problem, the threads of the stud and the threads of the inner cap nut should be cleaned with a wire brush.

WHEEL MAINTENANCE

Thoroughly remove rust, dirt, and other foreign materials from all surfaces. Hand or electric wire brushes, sand blasting or chemical baths may be used.

Bead seat areas of rim should be free of rust and rubber deposits. This is especially important for drop-center tubeless rims, because the 15° bead seat is the air-sealing element.

Paint rim by brush or spray with a fast-drying metal primer. Surfaces should be clean and dry prior to painting. Ensure that bare metal areas on outside or tire side of rim are covered. This is especially important on drop-center tubeless rims, because warm and sometimes moist air is in constant contact with the metal surface on the tire side of the rim.

TIRE ROTATION

Rotation of the tires will minimize tire trouble and produce longer tire life. With rotation, accelerated and irregular tire wear on any one particular tire will be spread out over several tires, and replacement frequency will be reduced. Tire wear may also contribute to such trouble as poor handling and shimmy.

If desired, the tires should be rotated every 6,000 miles following one of the patterns shown in Figure 3.

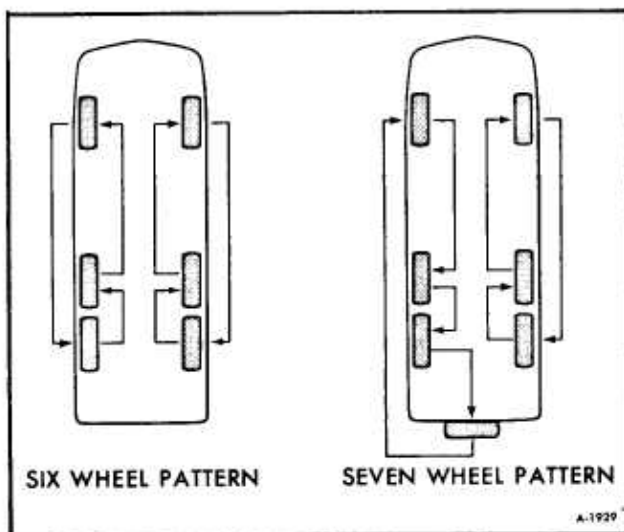

Figure 3-Tire Rotation Diagram

INFLATION OF TIRES (FIGURE 4)

Inflate to correct pressure when tires are cool. If tires are continually carrying less than the recommended maximum load, adjust air pressure downward to correspond to the actual load carried.

Never "bleed" tires to relieve build-up of pressure. Tire temperature will increase when the tire is in service and allows for the normal build-up in air pressure. Tire temperature and air pressure will remain within limits that are not harmful to the tire when used in accordance with the recommendations for load and air pressure.

If excessive build-up of air pressure occurs, overload, underinflation, speed, or a combination of these is responsible. Use the size and type of tire that has the capacity to carry the load at recommended cold starting pressure.

The fabric, rubber, bead, contour, and size of tires used on these vehicles are designed to obtain maximum length of service under normal operating conditions. **TIRES ARE DESIGNED TO OPER-**

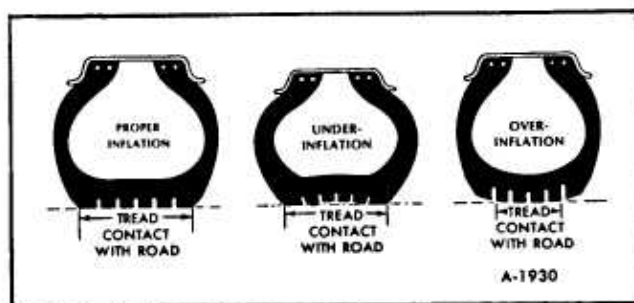

Figure 4-Inflation of Tires

ATE EFFICIENTLY ONLY ON A PRESCRIBED AMOUNT OF AIR. Unless the correct air pressure is consistently maintained, the tires will not function as they should; consistently, safe economical operation of vehicle will be materially affected.

An under-inflated tire runs sluggishly, heats up quickly because of the greater flexing, and is subjected to more frequent bruising.

On the other hand, over-inflation may weaken the tire, causing a blow-out. In addition to the deteriorating effect improperly inflated tires may have on the tire life, this condition will affect steering, riding comfort, and safe driving.

For correct inflation pressure refer to Specifications later in this section.

BALANCED INFLATION

The whole efficiency of the vehicle will be upset if air pressure in the tires are out-of-balance. Balanced inflation may be expressed as: All tires should always carry the same air pressure. A 5-pound under-inflation in one front tire not only can destroy ease of steering, but creates steering hazards which generally point to a potential accident. An under-inflated rear tire can destroy the value of the most efficient brakes. Balance tires for ease of steering, comfort in riding, safety in driving, as well as for minimum fuel consumption and maximum tire mileage.

PRESSURE LOSS

At periodic intervals, each tire should be gauged for pressure loss with an accurate gauge before tires are brought to correct operating pressure. The purpose of this check is to determine the exact pressure loss in each tire. In other words, if at the time this check is made, a definite pressure loss is noted in any one of the tires, an inspection should be made of the tire showing the loss and the cause of loss corrected. This method should definitely establish a "danger signal" on the condition of the tires. The pressure loss check should be made consistently with the same gauge, so that any element of inaccuracy in the gauge will be the same for all tires.

WHEEL AND TIRE BALANCING

It is desirable from the standpoints of tire wear and vehicle handling ease to maintain proper balance

of front wheel and tire assemblies. All wheels intended for use on front of vehicle, such as those switched during periodic tire rotation and those installed as new or repaired replacement equipment should be accurately balanced. This may be accomplished by either of two types of balancing systems in current use which balance wheels either on the vehicle or off. The "on-the-vehicle" type, however, is the more desirable in that all rolling components (brakes, bearings, seals, etc.), are included in the balancing procedure and thereby have any existing unbalance corrected.

Wheel balance is the equal distribution of the weight of the wheel and tire assembly around the axis of rotation. There are two ways in which wheels can be balanced—statically and dynamically.

STATIC BALANCE

Static balance (sometimes called still balance) is the equal distribution of weight of the wheel and tire assembly about the axis of rotation in such a manner that the assembly has no tendency to rotate by itself, regardless of its position. For example: A wheel with a chunk of dirt on the rim will always rotate by itself until the heavy side is at the bottom. Any wheel with a heavy side like this is statically out-of-balance. Static unbalance of a wheel causes a hopping or pounding action (up and down) which frequently leads to wheel "flutter" and quite often to wheel "tramp."

DYNAMIC BALANCE

Dynamic balance (sometimes called running balance) means that the wheel must be in static balance,

and also run smoothly at all speeds on an axis which runs through the center line of the wheel and tire and is perpendicular to the axis of rotation.

To ensure successful, accurate balancing, the following precautions must be observed:

Wheel and tire must be clean and free from all foreign matter. The tires should be in good condition and properly mounted with the balance mark on the tire, if any, lined up with the valve.

Bent wheels that have run-out over $3/32$ " should be replaced.

Inspect tire and wheel assembly to determine if an eccentric or out-of-round condition exists. Note that this condition, if severe, cannot be "balanced out." An assembly which has an out-of-round condition exceeding $5/16$ " is not suitable for use on the front of the vehicle. Its use on the rear should be governed by its general condition and whether the roundness defect seriously detracts from overall ride quality.

WARNING: WHEN BALANCING TIRES ON THE VEHICLE, FOLLOW THE EQUIPMENT MANUFACTURER'S INSTRUCTIONS CAREFULLY. DRIVE WHEEL SPIN SHOULD BE LIMITED TO 35 MPH AS INDICATED ON THE SPEEDOMETER. THIS LIMIT IS NECESSARY BECAUSE THE SPEEDOMETER ONLY INDICATES ONE-HALF OF THE ACTUAL WHEEL SPEED WHEN ONE DRIVE WHEEL IS SPINNING AND THE OTHER DRIVE WHEEL IS STOPPED. UNLESS CARE IS TAKEN IN LIMITING DRIVE WHEEL SPIN, THE SPINNING WHEEL CAN REACH EXCESSIVE SPEEDS, RESULTING IN POSSIBLE TIRE DISINTEGRATION OR DIFFERENTIAL FAILURE, WHICH COULD CAUSE PERSONAL INJURY OR EXTENSIVE VEHICLE DAMAGE.

TIRE REPLACEMENT

When tires are mounted on dirty or corroded rims, or when they are not properly centered on rims, the tire bead may "bind" on the rim, and refuse to seat. Allowing pressure to continue to build up within the assembly in an attempt to seat the tire bead is a **DANGEROUS PRACTICE** which can result in a broken tire bead, and serious injury to the serviceman. All of the following safety precautions should be observed:

1. Make sure that rim flanges and bead ledge (especially hump and radius) areas are smooth and

clean. Remove any oxidized rubber, dried soap solution, rust, heavy paint, etc., with a wire brush, or in extreme cases, a file.

NOTE: Repaint bare metal with a good grade of aluminum paint or equivalent, to prevent rust.

2. Lubricate tire beads, rim flanges, and bead ledge areas with a liberal amount of thin vegetable oil soap solution, or approved rubber lubricant.

3. Ensure that air pressure build-up during the



Figure 5—Lubricating Tire Bead



Figure 6—Working Bead Onto Rim

bead seating process is not allowed to exceed 100 pounds pressure.

IMPORTANT: If beads have not seated by the time pressure reaches 80 pounds, assembly should be deflated, repositioned on rim, relubricated, and re-inflated.

4. Make sure valve core is inserted in valve stem prior to inflating.

5. Use an extension gauge with clip on chuck so air pressure build-up can be closely watched and so that you can stand well back from the assembly during the bead seating process to avoid possibility of personal injury.

MOUNTING

1. Inspect rim to insure bead seats are clean and smooth. Then place rim on floor with wide side down and lubricate first bead of tire and upper bead seat of rim (figure 5).

2. Push first bead into well of rim and onto rim as far as possible. Using straight end of tire iron and with stop resting on rim flange, work remaining section of first bead over rim (figure 6).



Figure 7—Working Second Bead Onto Rim



Figure 8—Inserting Tire Iron to Lift Bead



Figure 10—Inserting Tire Iron in Second Bead



Figure 9—Lifting Bead Over Rim



Figure 11—Prying Second Bead from Rim

3. Hold second bead in well by standing on tire. When necessary, push section of bead into rim well and anchor with vise-grip pliers by pinching pliers on rim flange. Using spoon end of tire iron with stop toward rim, work progressively around bead using small bites until bead slips over flange onto rim base. If necessary, insert second tire iron and lubricate last 6" of bead before completing mounting (figure 7).

4. Check valve to be certain that hex nut at the valve base is tight. Inflate tire to recommended operating pressure. Check assembly for air leaks.

DEMOUNTING

1. Remove valve core to completely deflate tire. With tire lying flat on floor, loosen beads from rim

seats by walking around on tire with heels at points close to rim. With wide side of rim down, apply tire lubricant to top bead. With stops toward rim, insert spoon ends of two tire irons about 10" apart. While standing on tire to hold bead in gutter, pull one tool toward center of rim (figure 8).

2. Hold one iron in position with foot and pull second iron toward center of rim. Progressively work bead off rim, taking additional bites if necessary (figure 9).

3. Stand assembly in vertical position. Lubricate second bead. At top of assembly insert straight end of tire iron between bead and back flange of rim at about a 45 degree angle (figure 10).

4. Turn iron so that it is perpendicular to rim. Pry second bead off (figure 11).

WHEEL AND TIRE INSPECTION

WHEEL AND TIRE WEAR

CORRECTING IRREGULAR TIRE WEAR

Heel and Toe Wear – This is a saw-toothed effect where one end of each tread block is worn more than the other. The end that wears is the one that first grips the road when the brakes are applied.

Heel and toe wear is less noticeable on front tires than on rear tires, because the propelling action of the front wheels creates a force which tends to wear the opposite end of the tread blocks. The two forces, propelling and braking, make for more even wear of the front tires, whereas only the braking forces act on the rear wheels, and the saw-toothed effect is more noticeable.

A certain amount of heel and toe wear is normal. Excessive wear is usually due to high speed driving and excessive use of brakes. The best remedy, in addition to cautioning the owner on his driving habits, is to rotate tires regularly.

Side Wear – This may be caused by incorrect wheel camber, underinflation, high cambered roads or by taking corners at too high a rate of speed.

The first two causes are the most common. Camber wear can be readily identified because it occurs only on one side of the treads, whereas underinflation causes wear on both sides. Camber wear requires correction of the camber first and then interchanging tires. There is, of course, no correction for high cambered roads. Cornering wear is discussed further on.

Misalignment Wear – This is wear due to excessive toe-in or toe-out. In either case, tires will revolve with a side motion and scrape the tread rubber off. If misalignment is severe, the rubber will be scraped off of both tires; if slight, only one will be affected.

The scraping action against the face of the tire causes a small feather edge of rubber to appear on one side of the tread and this feather edge is certain indication of misalignment. The remedy is readjusting toe-in, or rechecking the entire front end alignment if necessary.

Cornering Wear – When a vehicle makes an extremely fast turn, the weight is shifted from an even loading on all wheels to an abnormal load on the tires on the outside of the curve and very light load on the inside tires, due to centrifugal force. This unequal loading may have two unfavorable results.

First, the front tires on the inside of the curve may be relieved of so much load that it is no longer geared to the road and it slips, grinding off the tread on the inside half of the tire at the excessive rate. This type of tire shows much the same appearance of tread wear as tire wear caused by negative camber.

Second, the transfer of weight may also overload the outside tires so much that they are laterally distorted resulting in excessive wear on the outside half of the tire, producing a type of wear like that caused by excessive positive camber.

Cornering wear can be most easily distinguished from abnormal camber wear by the rounding of the

outside shoulder or edge of the tire and by the roughening of the tread surface which denotes abrasion.

Cornering wear often produces a fin or raised portion along the inside edge of each row in the tread pattern. In some cases this fin is almost as pronounced as a toe-in fin, and in others, it tapers into a row of tread blocks to such an extent that the tire has a definite "step wear" appearance.

The only remedy for cornering wear is proper instruction of operations. Driving more slowly on curves and turns will avoid grinding rubber off tires. To offset normal cornering wear as much as possible, tires should be rotated at regular intervals.

Uneven Wear – Uneven or spotty wear is due to such irregularities as unequal caster or camber, bent front suspension parts, out-of-balance wheels, brake drums out-of-round, brakes out of adjustment or other mechanical conditions. The remedy in each case consists of locating the mechanical defect and correcting it.

Power and Speed – Excessive speed has always been harmful to tires. Speed creates heat – heat softens tires.

Stops and Starts – Quick stops and starts grind off tread in a hurry, may cause flat spots which continue to grow for the life of the tire.

Temperature – Considerably less mileage can be expected from a tire used in all warm weather driving as compared to all cool weather driving, or from a tire first put into service in warm weather.

MECHANICAL IRREGULARITIES

Following are some wheel or vehicle irregularities which may cause rapid or uneven tread wear:

Toe-In – The wheels on the same axle are closer together in the front than they are in the rear. When toe-in is excessive the tire wear shows feathered edges on inside edge of the skid design.

Toe-Out – The wheels on the same axle are closer together in the rear than they are in the front. Tire wear shows feathered edges on outside edge of the skid design.

Camber – This designates the tilt of the wheel. Positive camber is when wheels are closer together at point of road contact. Negative camber is when wheels are closer together at top. Too much camber results in excessive wear on one side of tire.

Caster – This is the backward tilt of the axle or inclination of the kingpin at the top. Too little caster causes wheel to wander or weave – result, spotty wear. Excessive caster may cause wheel "flight" or shimmy wear. Unequal caster causes wheel to pull to one side, resulting in excessive and uneven wear.

Sprung or Twisted Frame – Will cause rapid or uneven tread wear.

Grabbing Brakes – Brakes out of adjustment and out-of-round brake drums or discs cause tire treads to wear rapidly in spots. Out-of-round brake drums usually wear out tires in a single spot. Improperly adjusted brakes produce several worn places.

Worn wheel bearings, unbalanced wheels, or wobbly wheels all result in uneven and irregular tread wear.

At first sign of uneven tire tread wear, check and correct all mechanical irregularities.

WHEEL INSPECTION

Do not use wheels with bent rims. The continued use of such wheels will result in excessive tire wear and, if wheel is mounted on front of vehicle, difficulty in steering will be experienced. Wheels that are thought to be distorted may be checked as follows, referring to Figure 12 for checking points:

1. Raise wheel at side to be checked and safely support underneath.

2. Tool for checking run-out may be readily improvised as follows:

Secure block of wood approximately 6" x 6" x 14" or material with suitable base so it will remain positioned. Secure thin piece of wood or suitable material 10 inches long, such as ruler or yardstick, and fasten to wood block to a height in relation to rim surfaces as shown in Figure 12. Tighten screw sufficiently so pointer will hold its position when adjusted.

3. Position pointer at crown of rim (A, figure 12). Slowly revolve wheel and move pointer toward wheel until it contacts wheel at nearest point.

4. Continue to revolve wheel and check amount of lateral run-out (amount of wheel side wobble). This should not exceed 3/32-inch.

5. Place point of marker at inside of wheel at point "B", in Figure 12. Follow the previous procedure to check radial run-out (out-of-round condition); this should not exceed 3/32-inch. If wheel is

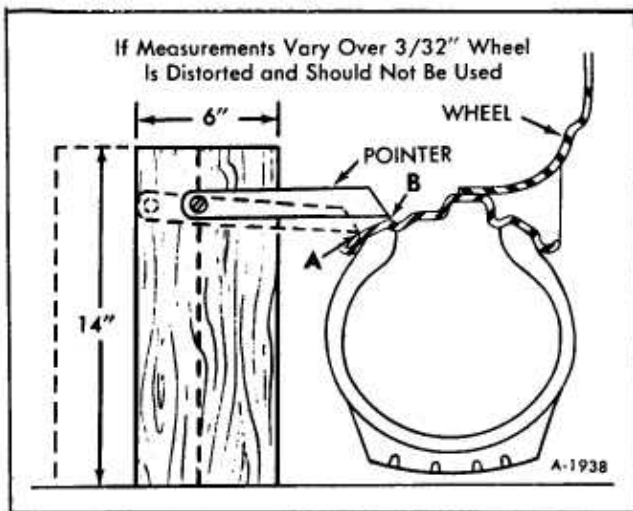

Figure 12—Method of Checking Distorted Wheels

distorted beyond these dimensions it should be replaced.

6. If doubt exists whether the wheel or hub is distorted, hub may be checked as follows: Replace the existing wheel with a wheel known to be true. Revolve the wheel and make the previously mentioned tests. If tests are within limits, the hub is satisfactory, but wheel is sprung.

7. A dismantled wheel may be checked for side wobble by placing a straight-edge on face or hub of wheel. Measure distance from straight-edge to edge of wheel rim, this should be checked at four equally spaced locations. If distance is the same at all positions wheel is not distorted. (See figure 13) A dismantled wheel may also be checked for radial, and lateral run-out if desired, by temporarily mounting it to a hub on vehicle. Follow the previous Steps 2, 3, 4, and 5.

WORN WHEEL STUD HOLES (FIGURE 14)

This condition will usually be accompanied by appearance of a shiny worn surface on wheel face, indicating that loose wheels were moving against

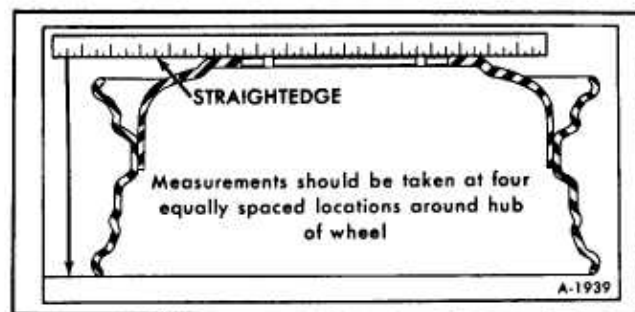

Figure 13—Wheel Checking Diagram

each other. If the stud holes are out of shape – oval or egg shaped – and where a build-up of metal is around them, these wheels must be replaced.

CRACKED DISC WHEELS (FIGURE 14)

Cracks running from hand-hole to stud-hole or bolt-hole to center-hole or hand-hole to hand-hole, or stud-hole to stud-hole, are a direct result of overloading. Check working loads of vehicle, discard damaged wheels, check wheel studs and complete assembly.

The hub assembly may have a worn mounting face as a result of moving of the wheel on the hub. The studs may have turned in the hub and worn the stud groove or the studs may have actual cracks or breaks resulting from this condition. The wheel may have worn ball seats in the stud holes. All these possibilities must be checked and all damaged parts replaced.

RUST STREAKS ON DISCS EMANATING FROM STUD HOLES

This is a positive indication that the cap nuts are, or have been, loose. In this case, the assembly should be checked carefully because damage to hub, studs, or wheel may have been caused by running in this condition.

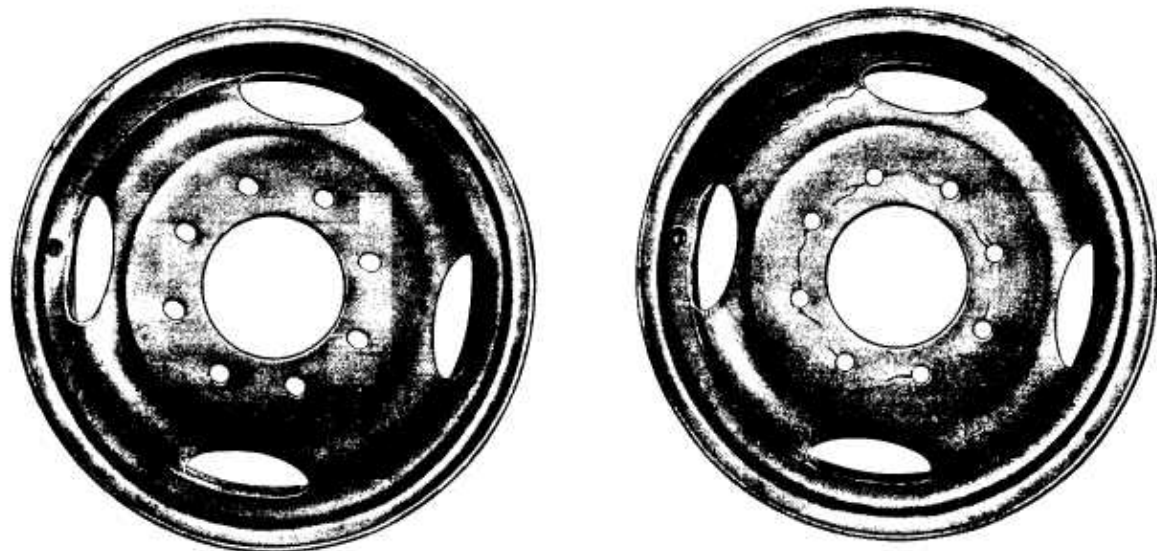

Figure 14—Worn Stud Holes and Cracked Disc Wheels

SPECIFICATIONS

Inflation Pressure (Cold).....	60 PSI
For Sustained Speeds Over 65 MPH	70 PSI
Tires	
Size	8.75–16.5
Load Range	D
Construction.....	Bias-Ply polyester Cord, Bias-Ply Steel Belted
Wheels	
Diameter.....	16.5"
Width	6.0"
Off Set	4.67"



SECTION 12 CHASSIS ELECTRICAL

Contents of this section are listed below:

SUBJECT	PAGE NO.
Instruments and Gauges	12- 1
Component Replacement	12- 2
Fuses and Fusible Links	12- 5
Printed Circuits	12- 6
Gauge Cluster	12- 6
Gauge Diagnosis Details	12- 7
Low Fuel Indicator Circuit	12-11
Miscellaneous	12-11
Wiring	12-13
General Maintenance	12-13
Left-Side Body Wiring	12-14
Front Wiring	12-14
Instrument Panel Wiring	12-14
Steering Column Wiring	12-14
Rear Body Wiring	12-15
Trailer Wiring	12-15
Lighting System	12-17
Headlamp Adjustment	12-17
Component Replacement	12-19
Fiber Optic Ribbon	12-20
Headlight Switch	12-23
Directional Signals	12-23
Dimmer Switch	12-23
Horn	12-23
Horn Diagnosis	12-24
Component Replacement	12-24
Radio and Tape Player	12-26
Radio and Tape Diagnosis	12-29
Servicing	12-29
Mobile Radio Transmitters	12-31
Cruise Control	12-31
General Description	12-31
Component Operation	12-31
Diagnosis	12-37
Servicing	12-37
Brake Release Switches	12-37
Engagement Switch	12-37
Servo	12-38
Regulator	12-38
Electrical System Check Out	12-38
Engagement Switch Test	12-39
Light Bulb Specifications	12-40

INSTRUMENTS AND GAUGES

All instruments and gauges are installed in the instrument cluster as shown in Figure 1.

The instrument panel gauges utilize printed cir-

cuits. They are connected to the vehicles wiring through a multiple terminal connectors which are plugged into the back side of the gauges.

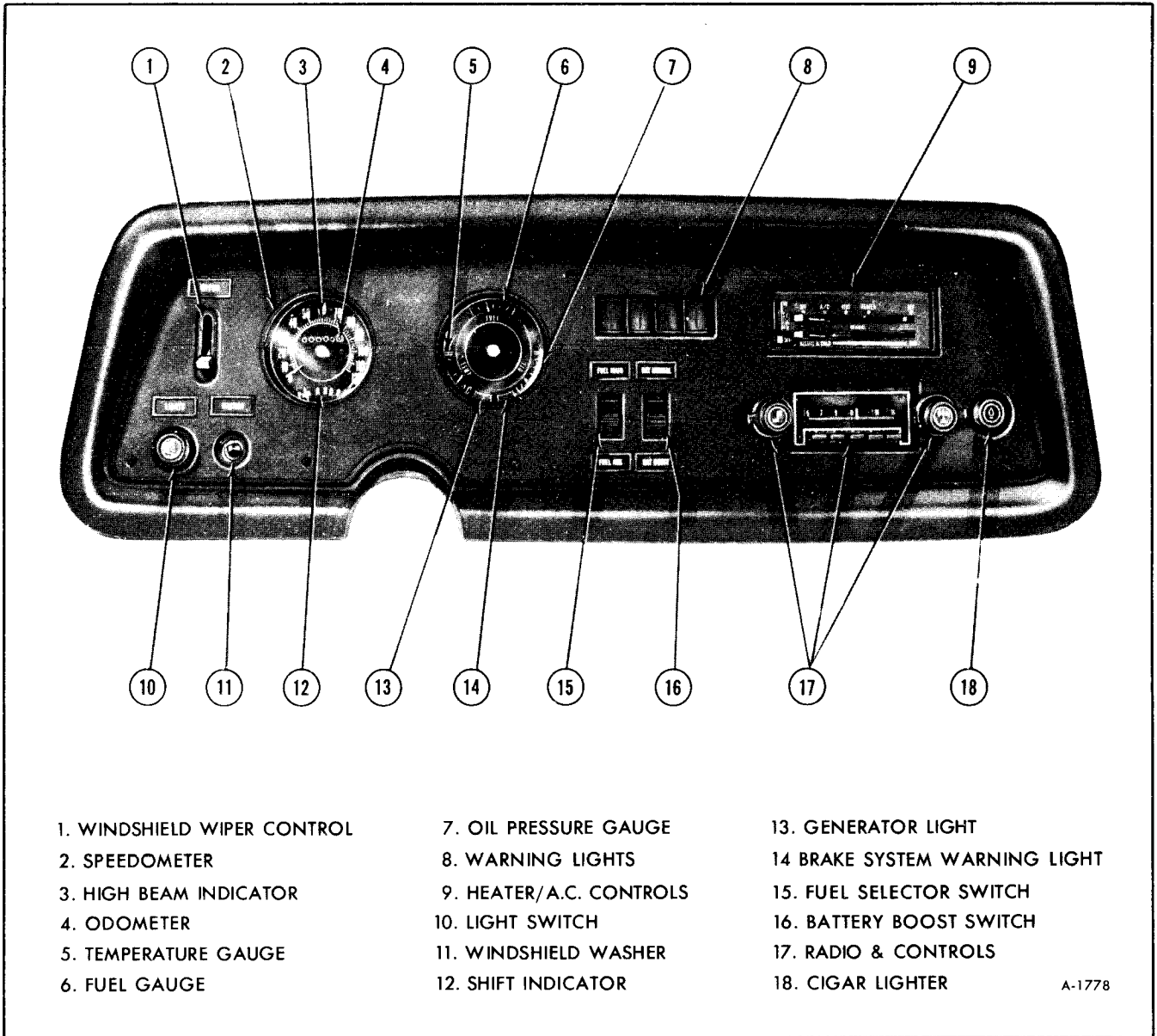

- | | | |
|-----------------------------|-------------------------|--------------------------------|
| 1. WINDSHIELD WIPER CONTROL | 7. OIL PRESSURE GAUGE | 13. GENERATOR LIGHT |
| 2. SPEEDOMETER | 8. WARNING LIGHTS | 14. BRAKE SYSTEM WARNING LIGHT |
| 3. HIGH BEAM INDICATOR | 9. HEATER/A.C. CONTROLS | 15. FUEL SELECTOR SWITCH |
| 4. ODOMETER | 10. LIGHT SWITCH | 16. BATTERY BOOST SWITCH |
| 5. TEMPERATURE GAUGE | 11. WINDSHIELD WASHER | 17. RADIO & CONTROLS |
| 6. FUEL GAUGE | 12. SHIFT INDICATOR | 18. CIGAR LIGHTER |

A-1778

Figure 1-Instrument Panel

Instruments and gauges can be serviced in the vehicle by removing the instrument bezel as described later in this section. Illumination and indicator lamps can be replaced without removing the gauges and are of a 1/2 turn locking type with printed circuit connections. Regular maintenance is not required on the instrument cluster other than maintaining clean, tight electrical connections, replacing defective parts and keeping the speedometer cable properly lubricated. Figure 2 shows instrument panel component installation.

INSTRUMENT PANEL BEZEL REPLACEMENT

1. Remove the radio knobs and control rings.

2. Remove the headlight switch knob as described under "HEADLIGHT SWITCH REPLACEMENT" later in this section. Then remove wiper control knob.

3. Disengage the fiber optic ribbon from the source bulb assembly located on the lower left side of the instrument panel assembly. This can be serviced from below the dash panel.

4. Remove the (4) upper bezel edge retaining screws and remove bezel from instrument panel.

5. To install, hook lower edge of the bezel on instrument panel edge and reverse steps 1-4 above.

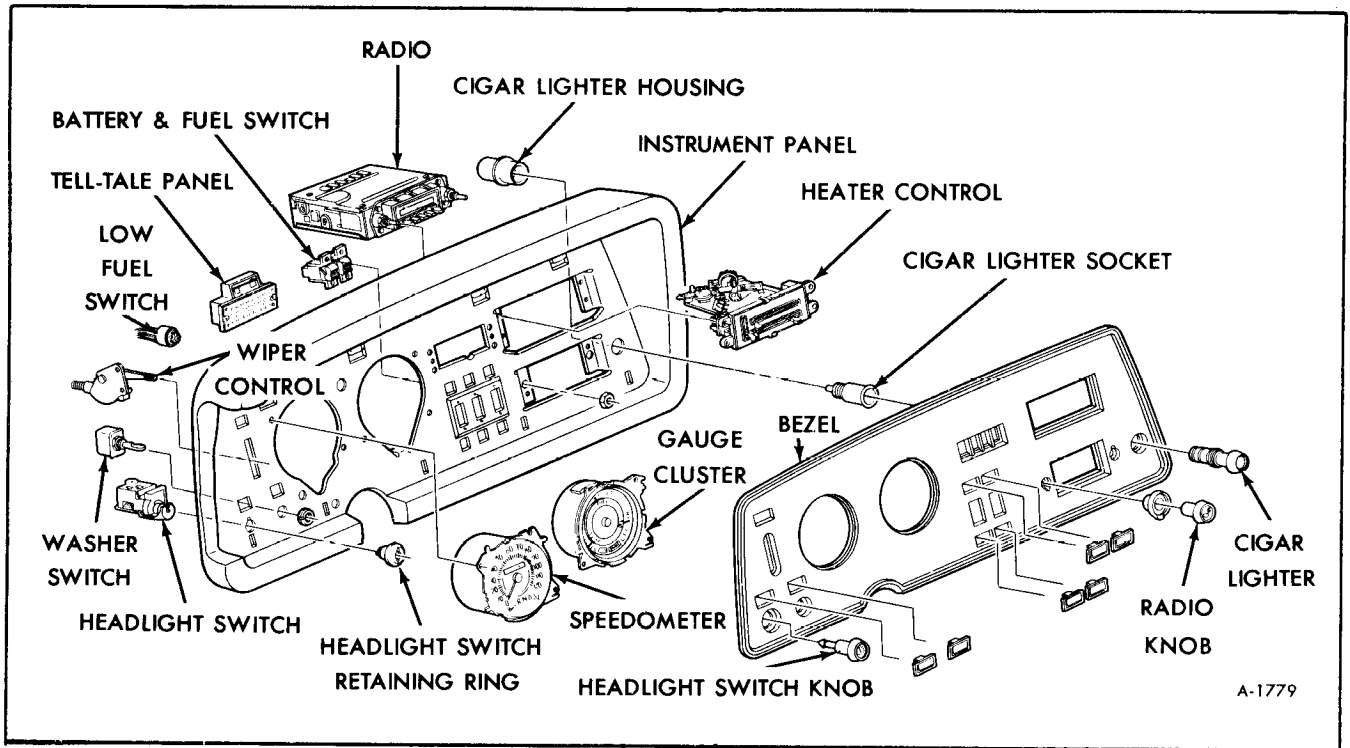

Figure 2-Instrument Panel Components

INSTRUMENT PANEL REAR COVER REPLACEMENT

1. Remove the (2) cover retaining screws on each side of the cover.
2. Lift cover straight up and work from behind the cluster assembly.
3. To install, reverse steps 1-2.

SPEEDOMETER HEAD REPLACEMENT

1. Disconnect battery ground cables.
2. Remove instrument panel bezel.
3. Remove instrument panel rear cover.
4. Remove the (3) speedometer retaining screws (See figure 3) and ground wire.
5. Hold the speedometer cable spring retaining clip down and pull cable away from speedometer head.
6. Disconnect (4) wire electrical connector from the back of the speedometer head.

7. Pull the speedometer head out and disconnect the transmission gear indicator cable.

8. Remove the speedometer head from the instrument panel.

9. When installing new or repaired speedometer head, the gear indicator cable should be routed around the metal post on the back side of the instrument panel. (See figure 4)

10. Reverse steps 1-8 to install speedometer head and test operation.

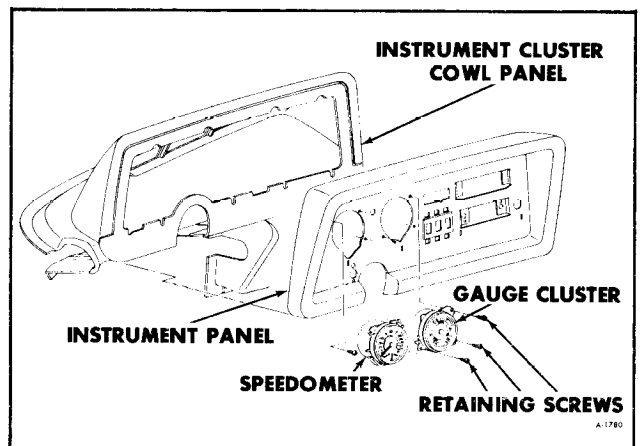

Figure 3-Speedometer and Gauge Cluster

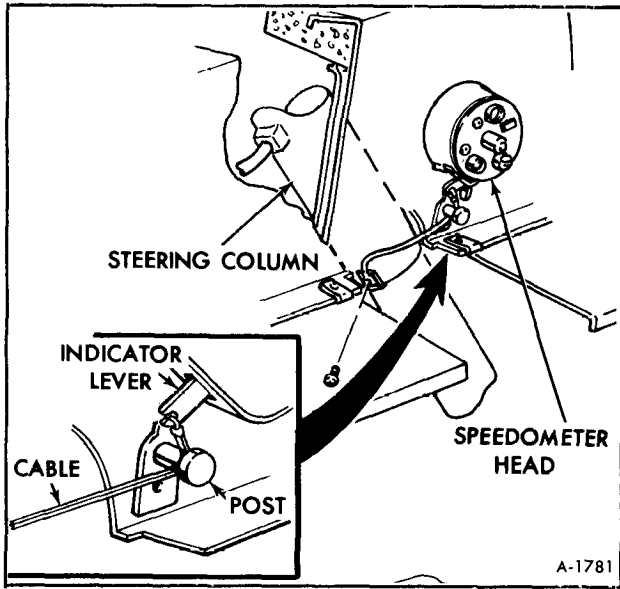

Figure 4—Gear Indicator Cable Connection

GAUGE CLUSTER REPLACEMENT (FIGURE 3)

1. Disconnect battery ground cables.
2. Removal the instrument panel bezel.
3. Remove the (3) gauge retaining screws and pull gauge out as far as possible. (See figure 3)
4. Disconnect the 7 wire pin connector from the gauge and remove gauge.
5. To install, reverse steps 1–4 above and check operation.

BATTERY SELECTOR SWITCH REPLACEMENT

1. Disconnect battery ground cables and remove instrument panel bezel.
2. Remove the (2) switch retaining screws shown in Figure 5.
3. Pull switch out as far as possible and disconnect the connector from the switch.
4. To install switch, reverse steps 1–3.

FUEL SELECTOR SWITCH REPLACEMENT

1. Disconnect battery ground cables and remove instrument panel bezel.

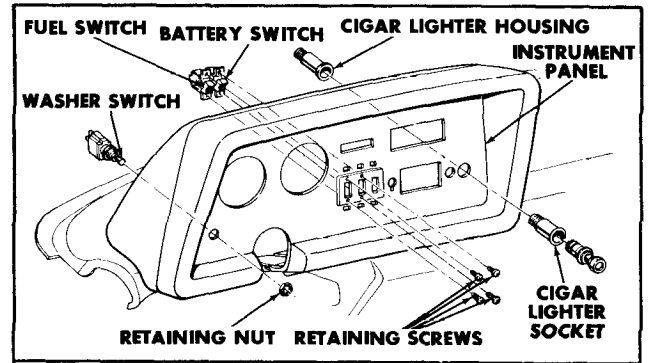

Figure 5—Battery and Fuel Switch Installation

2. Remove the (2) switch retaining screws shown in Figure 5.
3. Pull switch out as far as possible and disconnect the connector from the switch.
4. To install switch, reverse steps 1–3.

TELL-TALE LIGHT PANEL REPLACEMENT

1. Disconnect the battery ground cables.
2. Remove the instrument panel rear cover.
3. Disconnect the tell-tale light panel electrical connector.
4. Remove the (2) panel retaining screws and remove the panel (See figure 6).
5. To install, reverse steps 1–4.

CIGAR LIGHTER REPLACEMENT

1. Remove the element portion of the lighter from the instrument panel.
2. Disconnect the battery ground cables.
3. Remove the rear instrument panel cover by removing the (2) screws at each side of the rear panel cover. Lift rear panel cover up and work out of instrument panel.
4. Locate the cigar lighter connector and remove from lighter housing.
5. Turn the lighter housing (rear) counter-clockwise while holding the front portion, remove the lighter assembly when the (2) pieces disengage. (See figure 5)

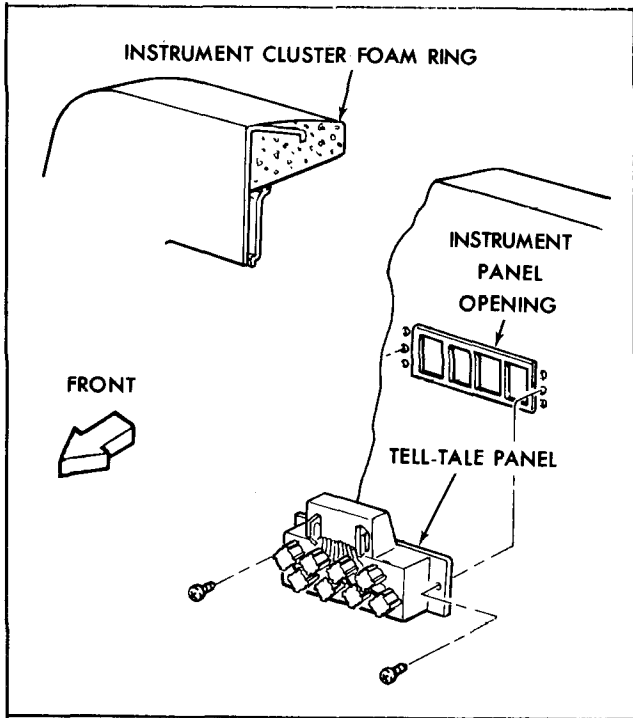

Figure 6-Tell-Tale Light Panel

6. To install lighter, reverse steps 1-5 and check operation.

SPEEDOMETER CABLE

The speedometer and odometer are driven by a gear train in the speedometer head, which is driven through a flexible shaft that is connected to the transmission. With cruise control, the speedometer cable is a two piece cable running from the speedometer head to the regulator unit and from there to the transmission.

Replacement

1. Disconnect the battery ground cables.
2. Remove rear instrument panel cover.
3. Disconnect speedometer cable from head by depressing spring clip and pulling cable core out of speedometer end of conduit.

NOTE: If cable is broken, it will be necessary to remove lower portions of cable from transmission end of conduit.

4. Lubricate cable with lubricant, then push cable into conduit. Connect upper end of cable to speedometer head and road test vehicle.

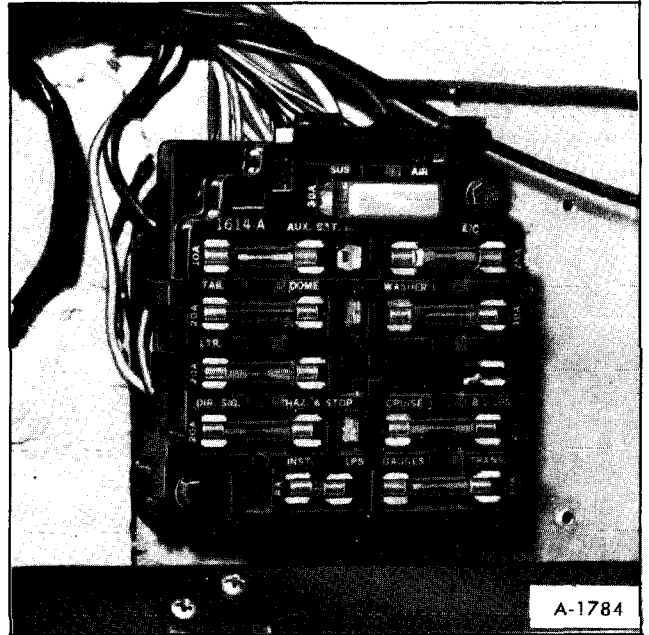

Figure 7-Fuse Panel

NOTE: Speedometer cable should be lubricated with AC Speedometer Cable lube ST-700 Part No. 6478535 or equivalent.

FUSES AND FUSIBLE LINKS

The fuse panel, Figure 7, is mounted on the bulkhead panel behind the glove box assembly. To gain access to the fuse panel, open the glove box and depress the hooking tang which allows the glove box to be swung out of the way.

The following fuses are located in this panel: aux. battery switch, heater-A/C tail and dome lights, windshield washer, cigar lighter, directional and stop lights, cruise control, transmission control and gauges, instrument lamps, and tell-tale lights. The following circuits employ circuit breakers or have fuses located as indicated:

- Headlight circuit breaker — built into switch
- Heater blower — built into line at right access door near heater blower
- Warning & signal flasher — in clip behind instrument panel
- Vehicle trouble light — in line, behind access door near light
- Rr suspension compressor circuit breaker — in fuse block

A fusible link is placed in the horn power feed circuit and is designed to protect wiring from damage in case of shorts.

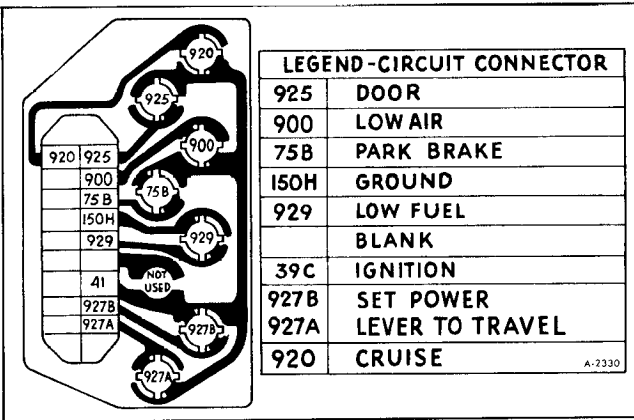

Figure 8-Tell-Tale Printed Circuit

PRINTED CIRCUITS

Printed circuits are used on the tell-tale lamp assembly, the speedometer and the gauge cluster to provide current for operation and illumination.

CHECKING CIRCUITS USING PRINTED CIRCUIT TELL-TALE LIGHT PANEL

Tell-tale printed circuit (figure 8) provides electrical contacts for illumination of various warning lights. Bulbs used in the tell-tale panel are listed in Specifications at the end of this section. To check the various tell-tale circuits proceed as follows:

a. Cruise control circuit (Refer to ENGINE & CHASSIS WIRING DIAGRAM).

1. Remove the instrument panel rear cover.
2. Remove the tell-tale light panel connector and remove the tell-tale panel.
3. With a continuity light, connect one probe of the test light to "41" of the printed circuit and the other probe to "920" with the cruise bulb in place. If the test light lights, the bulb and the circuit are good. If the test light does not light proceed to step 4.
4. If the test light does not light, remove the "920" bulb, "cruise" and check bulb, if bulb is good, problem is in the cruise tell-tale printed circuit board.

b. Door ajar.

1. With the tell-tale panel removed jump across the "925" and "41" terminals of the printed circuit with a self-powered test light.

2. If the test light lights, the circuit is good, if it does not proceed to step 3.

3. If the test light does not light, remove the

"DOOR" bulb and check, if good, problem is in the printed circuit board.

c. Low air.

1. Follow the same procedure as described under "DOOR AJAR" circuit but use terminals "900" and "41".

d. Park Brake 1. Follow the same procedure as described under "DOOR AJAR" circuit but use terminals "75B" and "41".

e. Low Fuel

1. With the tell-tale panel removed, connect the test light probes between "929" and "150H", if test light lights circuit is good, if it does not, follow the same procedures explained under "DOOR AJAR" tell-tale.

f. Set Power Lever To Travel

1. Follow the same procedure outlined for "DOOR AJAR" circuit but use both "927B" and "927A" to check for continuity to terminal "41".

SPEEDOMETER CIRCUIT

The speedometer printed circuit shown in Figure 9 provides electrical paths for the hi-beam, turn indicator and illumination lamp. As can be seen from Figure 9 the "F" terminal of the circuit provides an illumination lamp and turn indicator lamp ground. In addition to the "F" terminal ground a separate L.H. side illumination lamp ground is provided through a printed circuit trace to the speedometer case. Illumination bulbs can be removed by turning them 1/4 turn and pulling out. They are accessible by removing the instrument panel lower access panel and reaching up to the speedometer head.

GAUGE CLUSTER

The fuel, engine temperature and oil pressure gauges are located in the gauge cluster. Connection

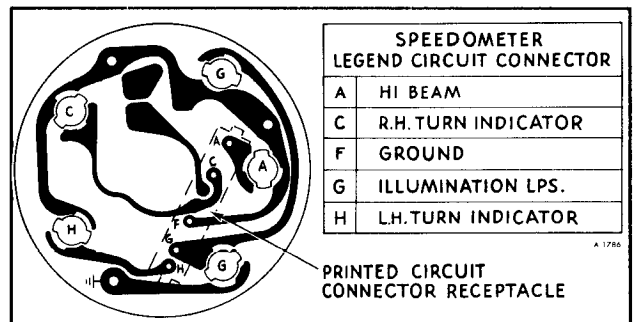

Figure 9-Speedometer Printed Circuit

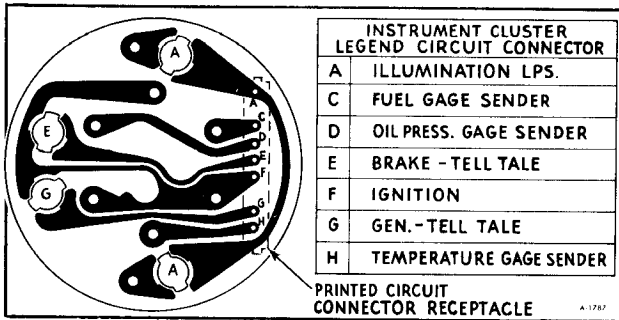

Figure 10—Gauge Cluster Printed Circuit

is made to this gauge by a (7) pin connector which feeds a printed circuit shown in Figure 10.

FUEL GAUGE

When checking the fuel gauge circuit, first determine whether the tank unit, wiring, or fuel gauge is faulty.

To check fuel gauge wiring, refer to Figure 19 for appropriate wiring harness connections. Connection at the gauge head is made through a printed circuit located at the rear of the gauge head. The fuel tank selector switch is located between the fuel gauge and the fuel sending units in the tanks. The fuel selector switch position determines which tank level is being measured.

CAUTION: *When checking fuel tank gauge wiring, never apply 12-volt current directly to the fuel tank float unit body feed wire as this will destroy the units' resistive element.*

The fuel gauge shows the approximate fuel level in the main tank when fuel selector switch is in the "FUEL MAIN" position, and the fuel level in the auxiliary tank when fuel selector switch is in the "FUEL AUX" position. The pointer will indicate the correct levels, only when the ignition is in the "ON" position. Since both fuel tanks are interconnected the gauge is designed to read the same (with the switch in either position) until approximately 60% of the total fuel capacity has been used.

If a condition is present where the vehicle is run in the "MAIN" position and allowed to deplete fuel supply on gauge, then switching to "AUX" does not provide the reserve 7 to 9 gallon amount, it is possible the wiring connector near the frame rail and tanks has the wires crossed in connection. The wires in this connection should be color to color from each side of the connector. This condition can also be detected by running in "AUX" position, switching to "MAIN" provides gauge reading of greater amount.

Changing the fuel selector switch position changes the fuel pick-up and fuel gauge sending unit from the main tank, as it goes empty, to the auxiliary tank, which will contain approximately 7 to 9 gallons of fuel.

FUEL GAUGE SYSTEM DIAGNOSIS

The following checks of the fuel indicator system will determine quickly whether incorrect fuel gauge readings are the result of an improperly operating fuel gauge, fuel tank sending unit or circuit wires. Refer to Figures 11 and 12 and also "Fuel Gauge Diagnosis Details" for fuel gauge system diagnosis.

GAUGE DIAGNOSIS DETAILS

ERRATIC FUEL GAUGE READINGS

Inspect all circuit wiring for damage to insulation or wire, also carefully check for proper electrical connection at the following locations:

1. Terminal connections at two-way connector to tanks.
2. Ground connection—one-way connector from tank to ground.
3. Body harness connector—10-way connector at instrument panel.
4. Body harness connector to printed circuit at gauge.
5. Mounting screws holding gauge to panel.
6. Make sure gauge pointer is not contacting face of gauge or lens.
7. Fuel selector switch connections.

GAUGE ALWAYS REGISTERS FULL (WITH IGNITION SWITCH ON)

Most probable cause is an open circuit in wiring or tank unit.

1. Check ground wires from tank units to ground. If loose, clean terminals, reinstall and check gauge reading.
2. Connect a spare tank unit to tank wiring. Raise and lower the float arm slowly, observing the dash unit (Be sure selector switch is in the appropriate position).

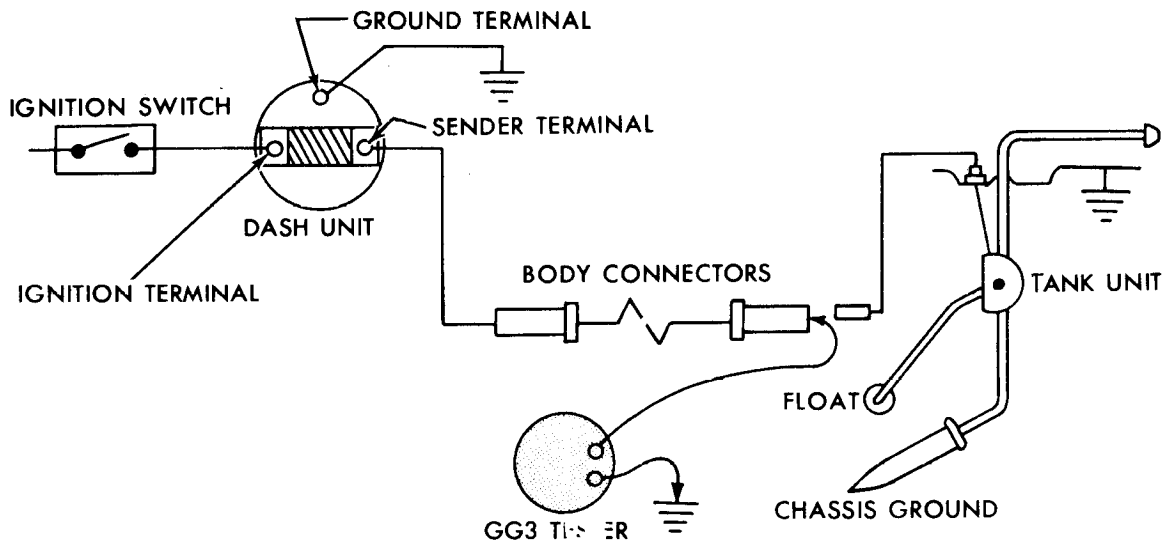

With vehicle on level surface, disconnect rear wiring connector and attach AC-GG3 tester between wire to dash unit and chassis ground.

Position ignition switch in "ON." DO NOT START ENGINE.

1. With tester knob set at "continuity" lamp should glow.
2. With tester knob set at "0" dash unit should indicate "EMPTY."
3. With tester knob set at "90" dash unit should indicate "FULL."

4. If 1, 2, and 3 above are OK, inspect tank unit ground and wire to tank unit. Repair as necessary to insure good electrical connections and no shorts throughout.

5. If fuel gauge system is still not functioning properly after completing Step 4, replace tank unit.

6. If any one of 1, 2, or 3 are not OK, inspect wiring from ignition switch to the rear wiring connector (including grounds). Repair as necessary to insure good electrical connections and no shorts throughout.

7. If any one of 1, 2, or 3 are still not OK after completing Step 6, replace dash unit.

Figure 11—Fuel Gauge Switch Diagnosis (Method Using AC-GG3 Tester)

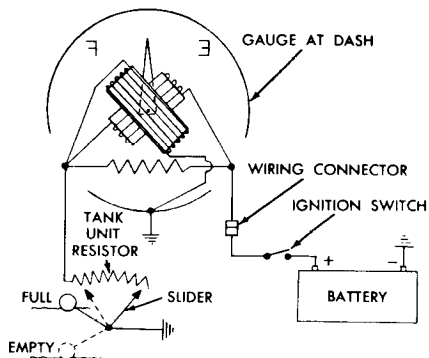

POSSIBLE COMPLAINT

Reads 1/4 when empty or won't read empty	Reads accurately above 1/4	Needle does not move	Reads "E" all the time	Reads "F" all the time	Reads 3/4 when full	Reads 1/4 when full or won't read full	Erratic reading
--	----------------------------	----------------------	------------------------	------------------------	---------------------	--	-----------------

PROBABLE CAUSE

SUGGESTED REMEDIES

PROBABLE CAUSE	Reads 1/4 when empty or won't read empty	Reads accurately above 1/4	Needle does not move	Reads "E" all the time	Reads "F" all the time	Reads 3/4 when full	Reads 1/4 when full or won't read full	SUGGESTED REMEDIES
1. Loose connection anywhere in circuit							x	Inspect and, if necessary, clean and tighten all connections in circuit
2. Poor dash fuel gauge calibration							x	Install new dash fuel gauge
3. Poor tank unit calibration							x	Install new tank unit*
4. Circuit grounded in resistor of tank unit					x	x		Install new tank unit*
5. Circuit grounded between tank unit resistor and dash gauge			x					Insulate grounded circuit
6. Circuit within dash gauge grounded.							x	Install new dash fuel gauge
7. Circuit grounded between battery and dash gauge.		x						Insulate grounded circuit
8. Open circuit between ignition switch and dash gauge		x						Clean and tighten appropriate terminals or repair broken wire
9. Open circuit between ground terminal on gauge and ground			x					Clean and tighten mounting bracket where contact is made between dash gauge and ground
10. Open circuit between sending unit terminal on dash gauge and resistor terminal on tank unit				x				Clean and tighten appropriate terminals or repair broken wire
11. Open circuit in resistor of tank unit at 1/4 full position	x							Install new tank unit*
12. Open circuit between tank unit slider resistor and ground				x				Install new tank unit*
13. Needle rubbing on face of gauge			x	x	x	x	x	Position needle to prevent contact with face or install new gauge
14. Fuel tank float hang-up	x		x	x	x	x	x	Free binding float or install new tank unit*
15. Top of fuel tank deformed					x			Straighten tank top or replace tank
16. Bottom of fuel tank deformed	x							Straighten bottom of tank or replace tank
17. Tank unit mounting flange bent	x				x	x		Straighten mounting flange or replace tank unit*

* Ignition switch must be "OFF" before removing tank sending unit, otherwise full battery voltage may destroy unit or ignite fuel vapors. For maximum safety, remove cable from negative battery terminal. A-1790

Figure 12-Fuel Gauge System Diagnosis

a. If dash unit does not function an open circuit at dash or tank unit is indicated.

b. If dash unit follows the arm movement proceed to step 3.

3. Inspect the wire terminals at the tank unit after lowering the fuel tank. If connection is loose, clean terminals and reinstall wires. If gauge continues to register "FULL" (with tank empty), remove the tank unit. Reconnect the wiring with unit out of tank, including the ground and move float arm. If dash unit does not follow arm movement, replace the tank unit.

GAUGE ALWAYS REGISTER EMPTY (WITH IGNITION SWITCH ON)

Most probable cause is a grounded circuit in the wiring due to a pinched or cut wire, or shorted fuel gauge dash unit. Disconnect the tank unit feed wire at the tank. The dash unit gauge should now register FULL.

Gauge Continues To Read Empty

1. Remove the instrument panel rear cover.
2. Remove the fuel gauge wire from the 7-wire connector on the gauge head (GRAY/DBL BLACK STR).
3. Gauge should now read FULL. If the gauge continues to read EMPTY, replace the dash unit.

Gauge Now Registers Full

1. Connect a spare tank unit to the tank feed wire at the body harness connector and ground unit at flange to chassis with a jumper wire.
2. Raise and lower float arm assembly while observing the dash unit.
 - a. If dash unit still does not operate, replace the dash unit after a continuity check of printed circuit has been made.
 - b. If the dash gauge follows the float arm movement, check tank unit feed wire for insulation breakdown. If wire is okay, replace the tank unit.
3. Check tank unit for improper installation of fuel filter screen which could restrict float movement.
4. If dash unit still does not follow the tank unit arm movement, replace the tank unit.

WATER TEMPERATURE GAUGE

When checking the water temperature gauge circuit, determine whether engine temperature sending unit, wiring, dash unit or printed circuit is faulty.

To check the engine water temperature sending unit, proceed as follows:

1. Disconnect wire at engine unit.
2. Connect a test light consisting of a 12V-2 candle power bulb and a pair of test leads in circuit by clipping one lead to battery positive terminal and other lead to body of engine gauge unit. If bulb lights, unit is properly grounded. If bulb does not light, check for presence of sealing compound around threads of unit. Remove compound and repeat test.
3. Remove test lead from body of unit and connect lead to terminal of unit. If bulb lights, engine unit is internally shorted and should be replaced.
4. Remove test light and reinstall wire on terminal.
5. If engine unit tests satisfactory under previous conditions, check the following items according to nature of difficulty:
 - a. If gauge does not register with ignition on: this may be caused by a break in the circuit between the gauge and the switch through the printed circuit or a short between the connector lead and the ground (See figure 10).
6. If gauge shows high temperature under all conditions, wire leading from gauge to engine unit is shorted to ground.
7. If gauge registers a low temperature reading under all conditions, wire between gauge and engine unit is broken.
8. Dash unit replacement should be made after the previous checks have been made for trouble source.

Do not attempt to repair either the engine unit or the gauge. When installing new engine unit, do not use thread compound on unit threads, as this will increase electrical resistance of unit and cause faulty reading on gauge.

OIL PRESSURE GAUGE

An electric oil pressure gauge is used on all vehi-

cles covered in this manual. A variable resistance sending unit is connected to an engine oil pressure gallery to vary the amount of resistance to ground with changes in engine oil pressure. Current is fed through the printed circuit on the back of the gauge (figure 10) from the wiring harness.

The oil pressure gauge can be checked for cause of difficulty using the following procedure:

1. Connect test lamp of not more than 2 candle power between battery positive terminal and the body of the sending unit. If lamp fails to light, the unit is not grounded, the threaded hole and threads on the unit should be checked for metal-to-metal contact. If the lamp lights the unit can be considered properly grounded. When replacing sending unit do not use compound on threads.

2. Remove the wire from the unit terminal and connect the test lamp between the unit terminal and the battery positive terminal. If the lamp lights, start engine and observe if the lamp changes intensity. A satisfactory unit will change the lamp intensity with changes in engine oil pressure. (DO NOT USE A LAMP OF OVER 2 candle power).

3. Connect the wire and check wiring for open circuit between unit and connector at the back of gauge head.

4. Check for continuity in printed circuit trace.

5. If no defective wiring or connections exist and sending unit checks out satisfactory, replace dash unit.

NOTE: No attempt should be made to repair either the gauge or the sending unit.

6. Refer to Figure 13 for further gauge diagnosis information.

LOW-FUEL INDICATOR CIRCUIT

The optional low fuel tell-tale indicator used on vehicles covered by this manual is activated by a voltage sensitive switch. As the fuel tank float changes position, a change in the tank unit circuit voltage is sensed by the low fuel switch. At a predetermined value, the switch will turn the low fuel light on, alerting the operator of the low fuel level. The low fuel switch is replaced from the rear of the instrument panel and is connected to the wiring harness through a 4 wire connector. Low fuel switch wiring is shown in Figure 14.

The low fuel switch can be checked for satisfactory operation by using the following procedure:

1. Locate the fuel tank unit feed wire and connect to ground.

2. Turn ignition switch to "ON".

3. Fuel gauge should read "EMPTY" and "low fuel" light in the tell-tale panel should be on. A low fuel condition is considered at approximately 1/16 to 1/8 tank level.

4. If light does not come on, check tell-tale bulb and replace if necessary.

5. If light still does not come on, check fuse panel (figure 7) for possible blown fuse at the "GAUGES" location.

6. Check switch wiring to fuel selector switch and to ground, if wiring is satisfactory and light still does not light, replace low fuel switch.

If low fuel indicator light remains on at all times when tank level is above the 1/16 to 1/8 level, replace the low fuel switch.

MISCELLANEOUS

DOME LIGHT SWITCH

The dome light switch, located on the speaker-dome light panel is a three position switch with the following functions:

1. Lamp operation (for that particular side) controlled by the headlight switch.

2. Lamp off, regardless of headlight switch position.

3. Lamp on, regardless of headlight switch position.

Switch Replacement

1. Disconnect the battery ground cables.

2. Remove the (4) dome light panel retaining screws.

3. Remove the (2) switch retaining screws.

4. Disconnect the dome lamp switch harness connector.

5. Remove the dome light switch.

6. To install, reverse steps 1-5 and check operation.

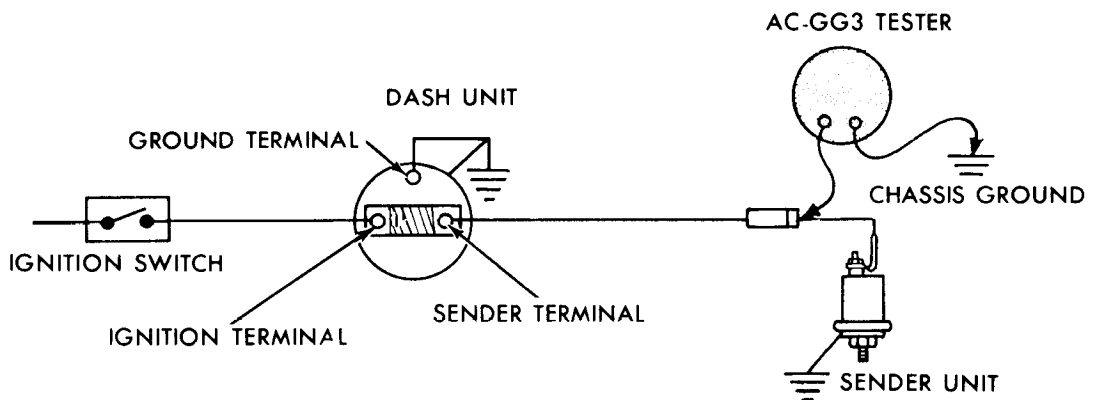

Disconnect wire from sender unit and attach AC-GG3 tester between this wire and chassis ground.

Position ignition switch to "ON." DO NOT START ENGINE.

1. With tester knob set at "Continuity," lamp should glow.
2. With tester knob set at "0," dash unit should indicate "0" psi.
3. With tester knob set at "90," dash unit should indicate "full scale" pressure.

4. If 1, 2, and 3 above are OK, clean sender terminal to insure good electrical contact with wire and make sure sender unit is grounding to engine.

5. If pressure gauge system is still not functioning properly after completing Step 4, replace sender unit.

6. If any one of 1, 2, and 3 are not OK, check wiring and all connections (including grounds).

7. If any one of 1, 2, and 3 are still not OK after completing Step 6, replace dash unit.

A-1791

Figure 13—Engine Oil Pressure Gauge Diagnosis (Method Using AC-GG3 Tester)

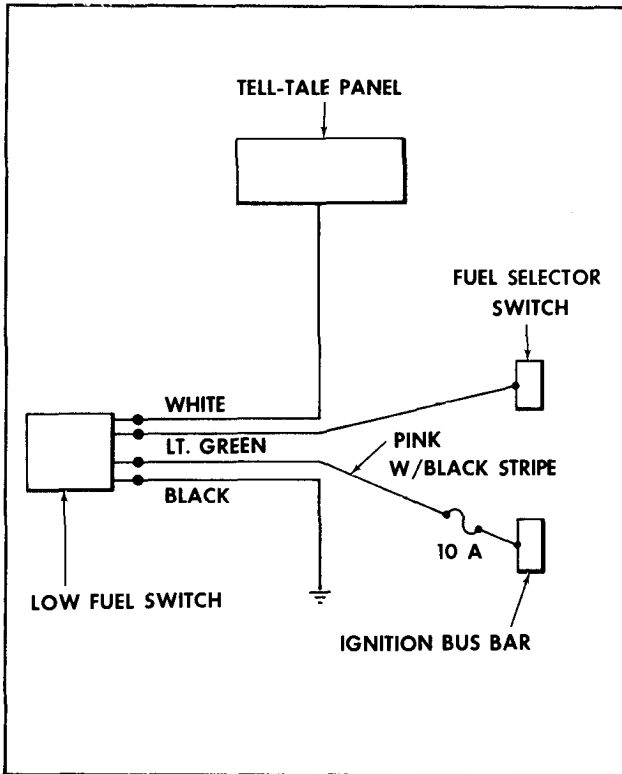

Figure 14—Low-Fuel Indicator Switch Circuit

WINDSHIELD WASHER SWITCH

The windshield washer switch is a spring loaded switch which returns to the off position when the

toggle is released. This switch supplies power to the windshield washer pump for pumping of washer solvent onto the windshield.

Switch Replacement

1. With a flat blade screwdriver engage the switch ring with the screwdriver blade while holding the back side of the switch (See figure 2).
2. Remove the retaining ring from the switch and bring the switch down to a more accessible position.
3. Disconnect the wiring harness connector from the switch.
4. Remove the switch from the panel.
5. To install, reverse steps 1–4, and check operation.

IGNITION SWITCH

The ignition switch is mounted on the right-side of the steering column. In addition to the steering column and shift lever lock feature, when the entrance door is open a buzzer located behind the left-hand engine access door would remind the driver to remove the key from the ignition switch. Replacement procedures for the ignition switch are covered in STEERING (SECTION 9) of this manual.

WIRING

GENERAL MAINTENANCE

Loose or corroded connections may cause a discharged battery in addition to difficult starting, dim lights and possible generator or regulator damage. A periodic check for clean and tight connections is important for dependable electrical system operation.

Wires and/or harnesses must be replaced if insulation becomes burned, cracked or deteriorated. Whenever it is necessary to splice a wire or repair one that is broken, always use rosin flux solder to join the wires and insulating tape to cover the splice on bare wires. Circuit tests for continuity can be made by referring to ENGINE AND CHASSIS WIRING DIAGRAM.

When replacing wire, it is important that the correct gauge be used.

NOTE: Never replace a wire with one of a smaller size. Fusible links in the wiring are four gauge sizes smaller than the wire it is designed to protect.

Fusible links are marked on the insulation with wire gauge size because of the heavy insulation which makes the link appear a heavier gauge than it actually is.

Each harness and wire must be held securely in place by clips or other holding devices to prevent chafing or wearing away the insulation due to vibration.

By referring to the wiring diagram, circuits may be tested for continuity or shorts with a conventional test lamp or voltmeter.

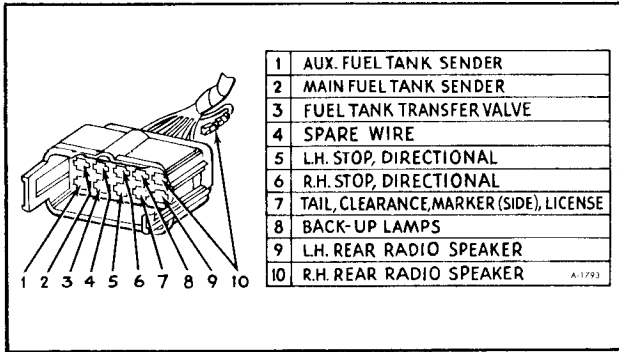

Figure 15-Left-Side Body Wiring Connector

LEFT-SIDE BODY WIRING

Wiring for rear lighting, fuel tanks and rear speakers passes through a (10) way multiple connector located in the front L.H. corner of the instrument panel. Rear lighting circuits can be checked for continuity through the female portion of this connector. Figure 15 shows the (10) way multiple connector and the appropriate wire position in the connector body. Refer to the vehicle wiring diagram for wire size and code used in the rear end wiring.

FRONT WIRING

Dome lights, headlamps and front clearance lights are fed through an (8) way multiple connector located under the instrument panel. The front lighting wiring is part of the instrument panel wiring harness. Figure 16 shows the female portion of the front lighting harness and the appropriate wire position in the connector body.

Front wiring for front clearance, identification, dome lamps and front speakers is shown in Figure 17. Door jamb switch wiring is found on the right hand side of the vehicle and is shown in Figure 18.

INSTRUMENT PANEL WIRING

Wiring to the instrument panel is made through multiple terminal connectors at the tell-tale panel, speedometer, headlight switch and cluster gauge.

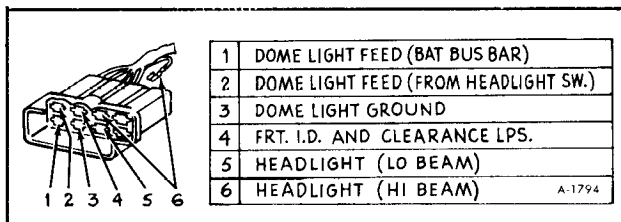

Figure 16-Front Wiring Connector

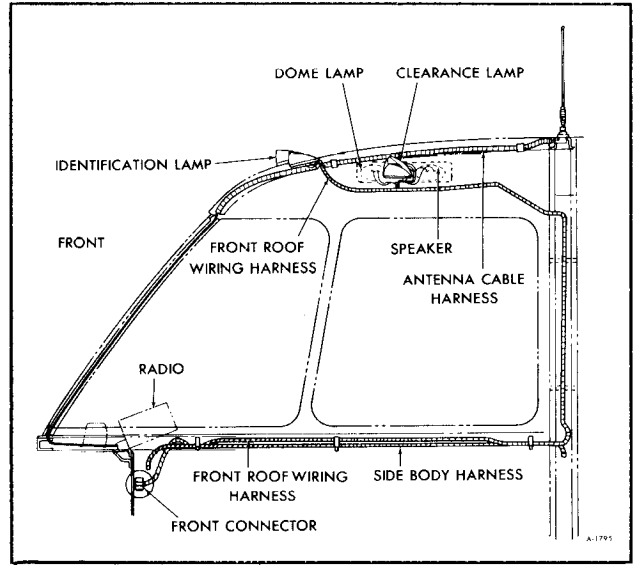

Figure 17-Front Wiring (Roof)

Figure 19, instrument panel, shows instrument wiring and proper connector location.

Radio wiring for AM and AM-FM Mono models is shown in Figure 20. Refer to ENGINE AND CHASSIS WIRING DIAGRAM for wire size and color application for instrument panel wiring.

STEERING COLUMN WIRING

Connections for directional signals, ignition switch, neutral safety switch, back-up lamps and

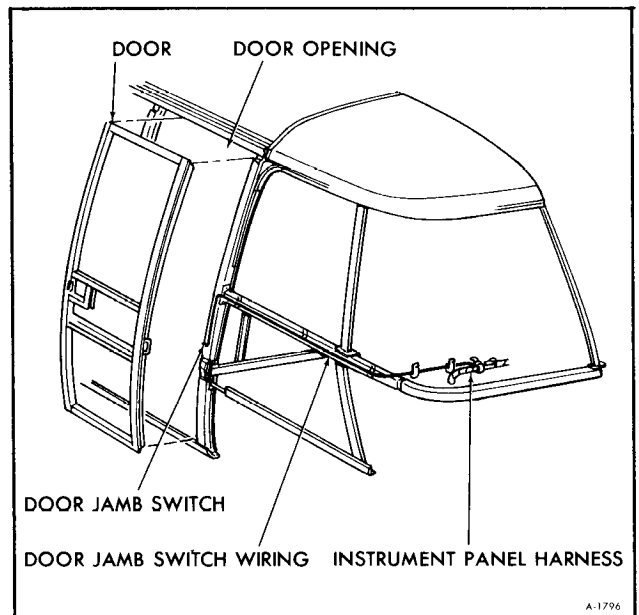

Figure 18-Door Jamb Switch Wiring (Model 230 Shown)

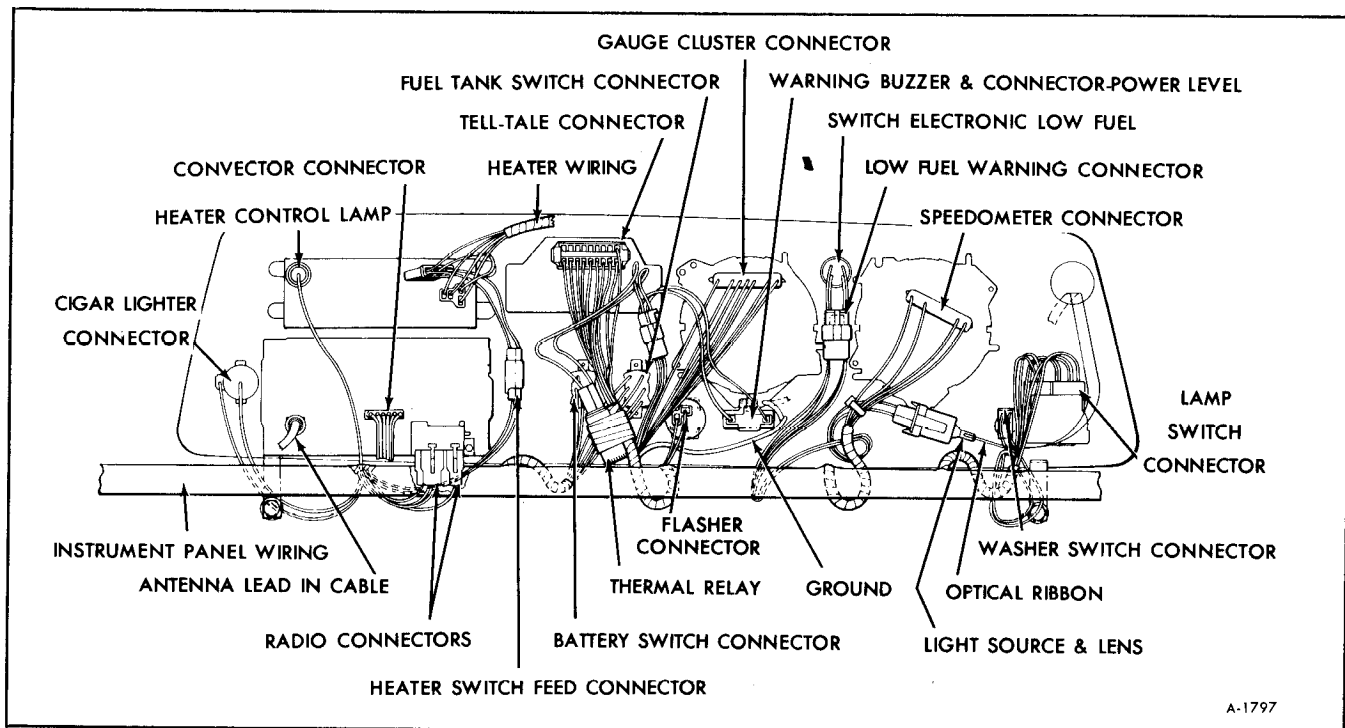

Figure 19-Instrument Panel Wiring

power leveler warning are shown in Figure 21. These connectors are located on the steering column. Refer to vehicle wiring diagram for applicable wire size and color.

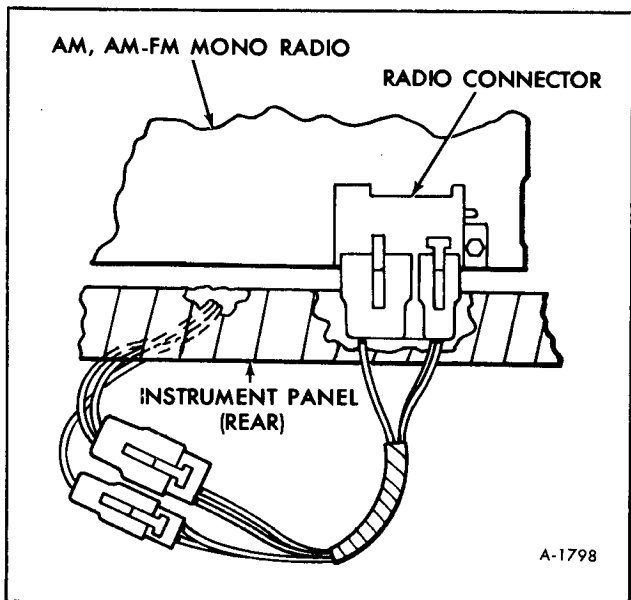

Figure 20-AM, AM-FM Mono Radio Connector

REAR BODY WIRING

Wiring for rear identification and clearance lamps along with rear speakers is fed around the rear of the body through a plastic loom. This harness is connected to the side body through a 6-way multiple connector located in the L.H. rear corner of the vehicle (See figure 22). Refer to ENGINE AND CHASSIS WIRING DIAGRAM for applicable wire size and color code.

TRAILER WIRING

The optional trailer wiring is installed as shown in Figure 23. This connection is made between the L.H. side body harness and the rear body harness at the L.H. rear corner of the vehicle.

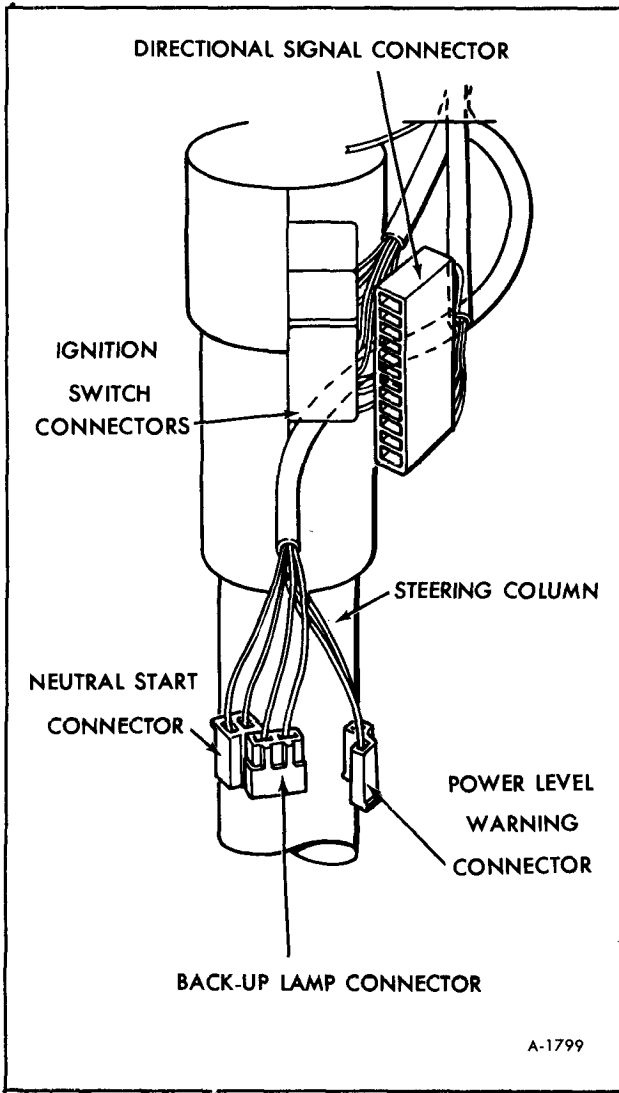

Figure 21-Steering Column Wiring

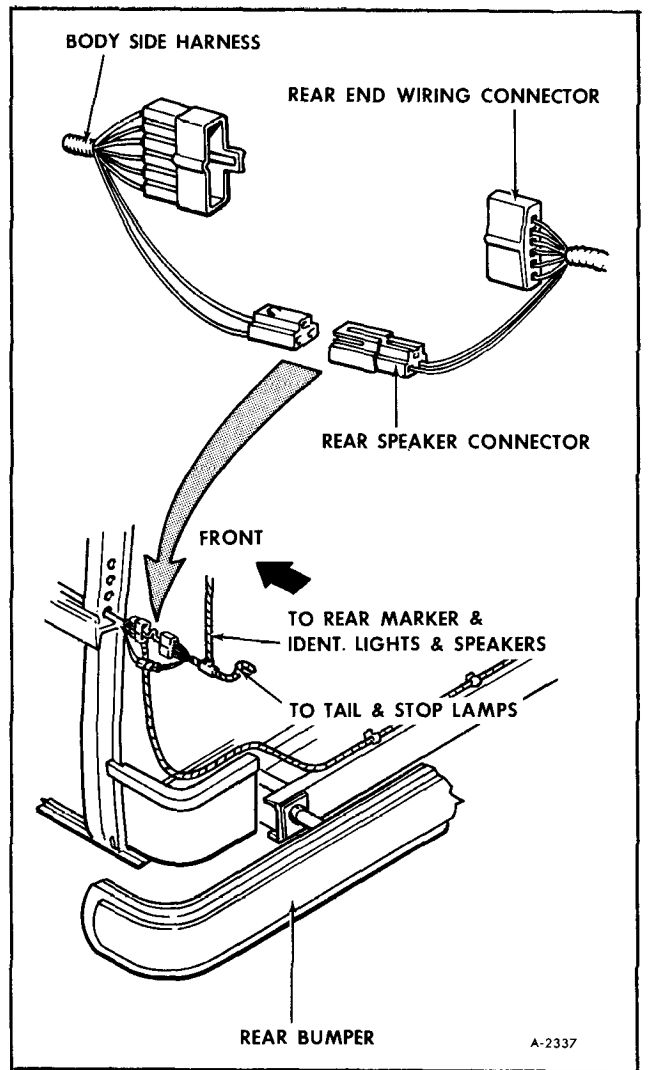

Figure 22-Rear Body Wiring

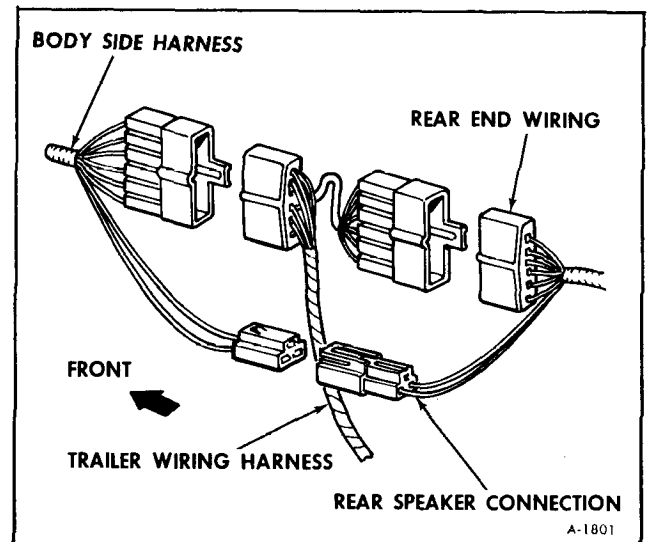

Figure 23-Trailer Wiring

LIGHTING SYSTEM

GENERAL INFORMATION

The lighting system includes the main light switch, stop light switch, dimmer and back-up lamp switches, head and parking lamps, stop, tail, side marker, clearance and identification lamps, porch light; instrument illumination, directional signal and indicator lamps and necessary wiring to complete the various circuits.

All Motor Home models use a single 7-inch single sealed-beam unit type headlight, all other lights are a replaceable bulb type. Refer to "Light Bulb Specifications" at the end of this section for bulb number.

HEADLAMP ADJUSTMENT

The headlamps must be properly aimed to obtain maximum road illumination. Proper aiming should be checked whenever a sealed beam unit is replaced or after any repair of the headlamp socket assembly. Regardless of the method used for checking headlamp aim, the vehicle must be at normal ride height, that is with gas, water and passenger weight most frequently traveled with.

NOTE: Some states have special headlamp aiming requirements which must be known and followed.

Horizontal and vertical aiming of each sealed beam is provided by two adjusting screws which move the mounting ring against the retaining spring tension (figure 24).

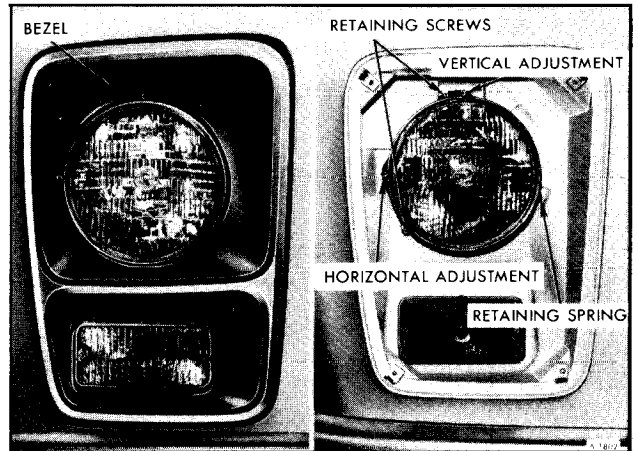

Figure 24—Headlamp Adjustment

HEADLAMP REPLACEMENT (FIGURE 25)

1. Remove (4) headlamp bezel retaining screws.
2. Disengage spring from retaining ring.
3. Turn headlamp unit to disengage assembly from headlamp adjusting screws.
4. Disconnect wiring harness connector located at the rear of the sealed beam assembly.

NOTE: Do not disturb adjusting screw setting.

5. Remove retaining ring and headlamp from mounting ring.

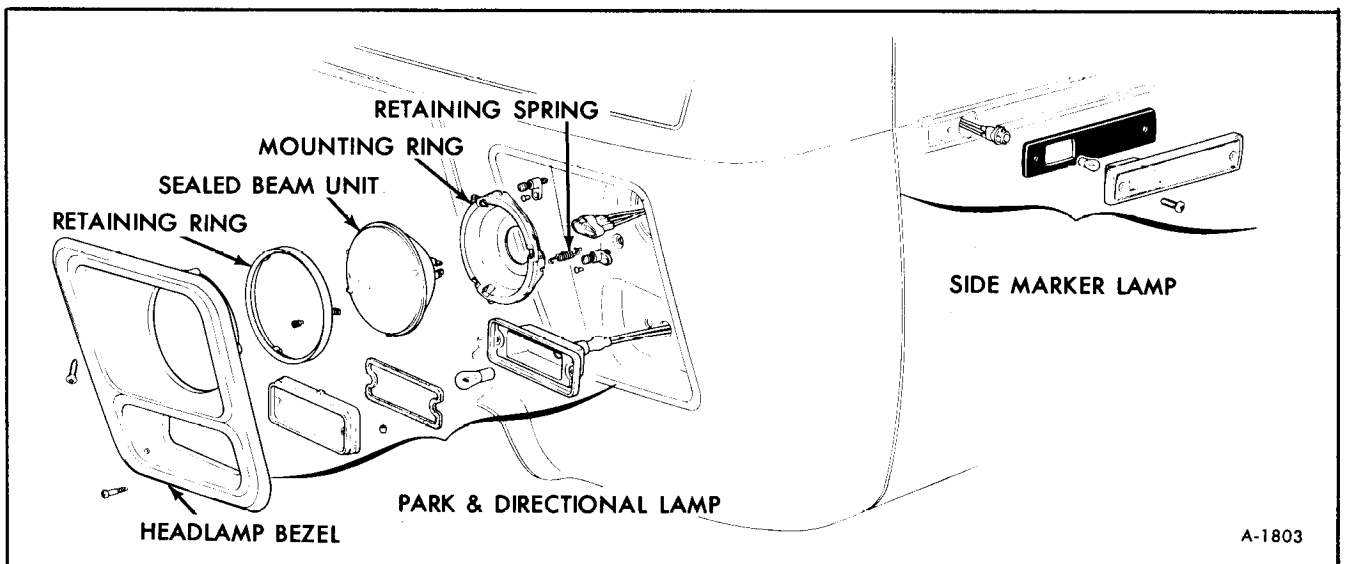

Figure 25—Headlamp and Side Marker Lamp Installation

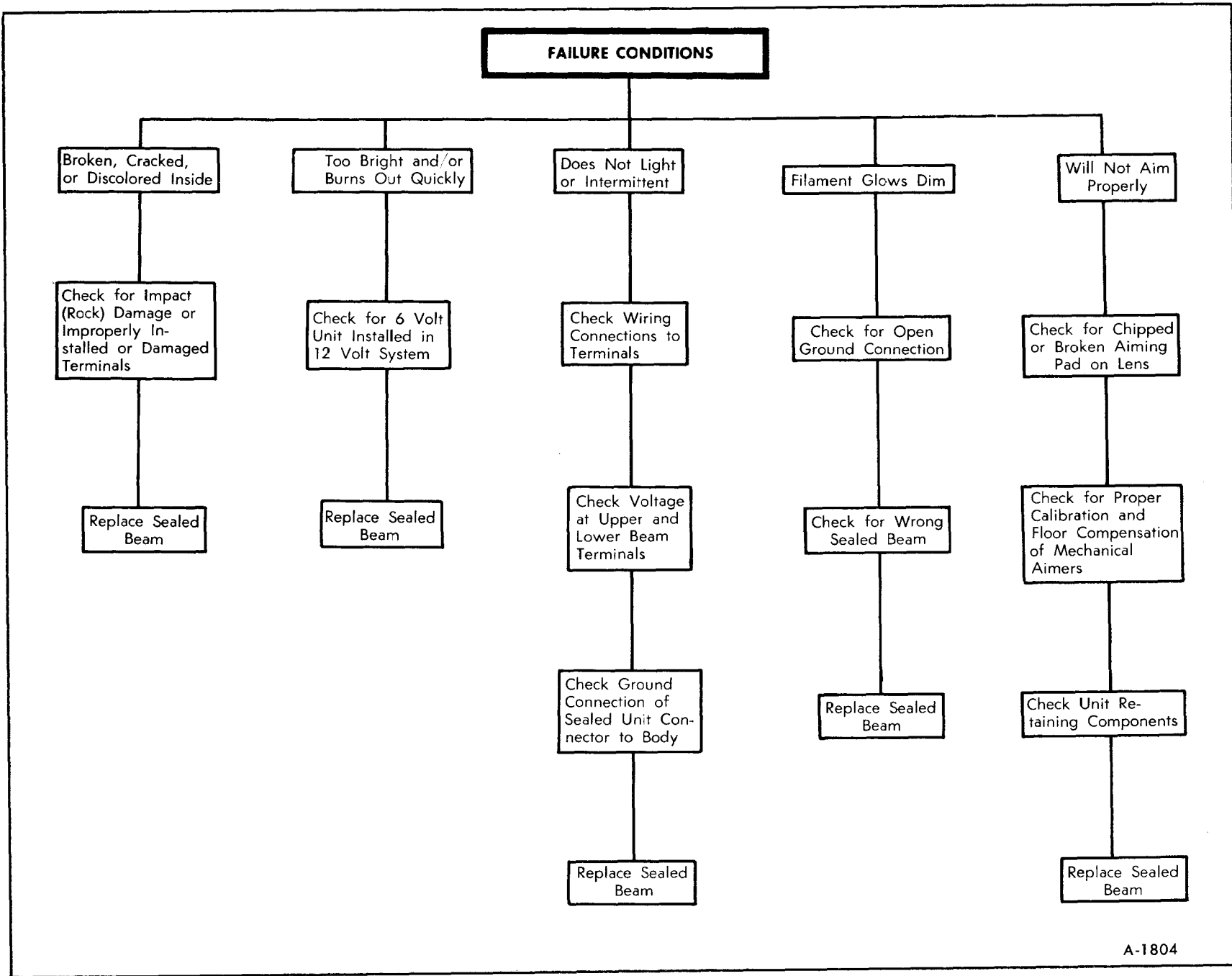

Figure 26-Headlamp Diagnosis

6. Position new sealed beam unit in mounting ring and install retaining ring.

NOTE: The number molded into lens face must be at the top of the bulb.

7. Attach wiring harness connector to unit.

8. Install headlamp assembly in panel opening, turning slightly to engage mounting ring tabs with adjusting screws.

9. Install headlamp retaining ring spring and check lamp aiming if adjusting screws have been turned.

10. Install headlight bezel with the (4) retaining screws.

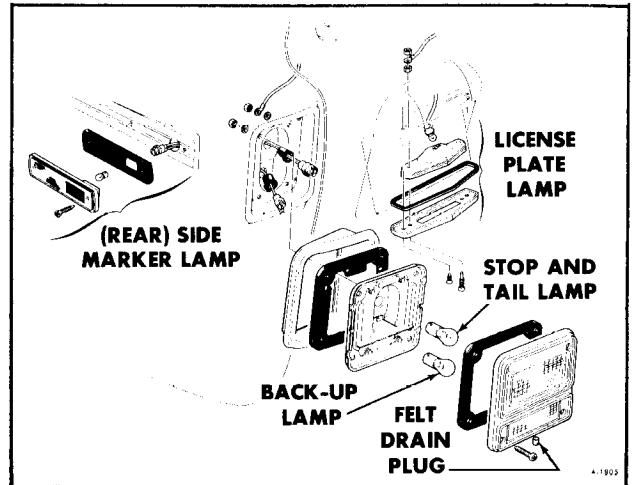

Figure 27—Tail, Stop, License and Rear Side Marker Lamps

HEADLAMP DIAGNOSIS

For details on headlamp diagnosis, refer to Figure 26. Additional diagnosis information is covered later in this section under “Headlight Switch”.

COMPONENT REPLACEMENT

PARKING AND DIRECTIONAL SIGNAL BULB (FRONT) REPLACEMENT (FIGURE 25)

1. Remove (2) lens retaining screws and remove lens from housing.

2. Replace bulb and check operation. See Specifications at the end of this section for bulb No.

3. Install lens and retaining screws.

SIDE MARKER LAMP BULB (FRONT AND REAR) REPLACEMENT (FIGURE 25 AND 27)

1. Remove (2) marker lamp retaining screws and remove lens.

2. Replace bulb and check operation. See Specifications at the end of this section for bulb No.

3. Install lens and retaining screws.

TAIL, STOP, BACK-UP AND DIRECTIONAL SIGNAL BULB REPLACEMENT (FIGURE 27)

1. Remove (4) lens retaining screws and remove defective bulb.

2. Replace bulb and check operation. See Specifications at the end of this section for bulb No.

3. Install lens and retaining screws.

NOTE: Check for proper positioning of lamp assembly felt drain plug (See figure 27).

LICENSE PLATE BULB REPLACEMENT (FIGURE 27)

1. Remove (2) outermost screws in license lamp lens.

2. Replace bulb and check operation by turning parking lamp on. See chart for bulb No.

3. Install lens with the (2) retaining screws.

CLEARANCE AND IDENTIFICATION BULB (FRONT AND REAR) REPLACEMENT (FIGURE 28)

1. Remove lens, retaining screw, and then remove lens.

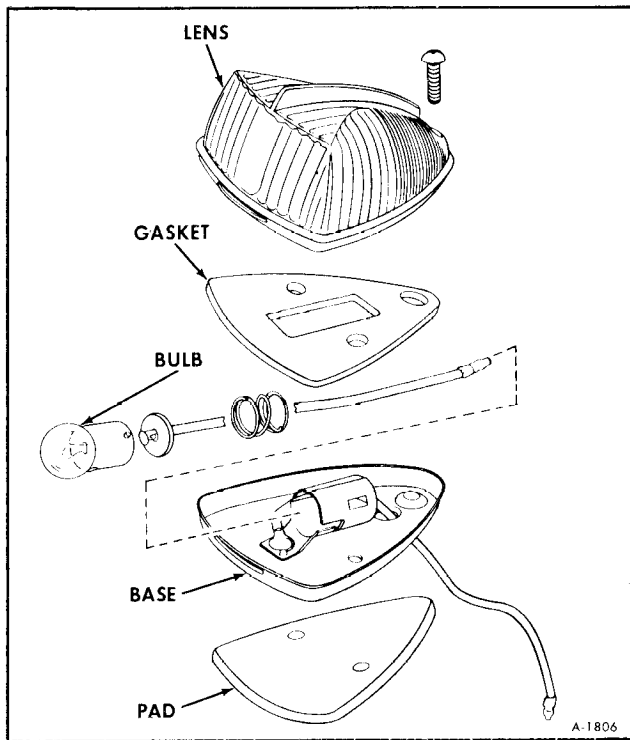

Figure 28—Clearance and Identification Lamp

2. Replace bulb and check operation. See Specifications at end of this section for bulb No.
3. Install lens and retaining screw.

DOME LAMP BULB REPLACEMENT (FIGURE 29)

1. Remove dome lamp lens by gently prying with flat blade screwdriver between lens and housing.
2. Replace bulb and check operation. See chart for bulb No. at the end of this section.
3. Snap dome lamp lens back into position by pushing lens as far as possible in housing, locking tabs will hold the lens in place.

ENGINE COMPARTMENT LAMP BULB REPLACEMENT

1. Remove the (2) lens retaining screws and then remove lens.
2. Replace bulb and check operation.
3. Install lens and retaining screws.

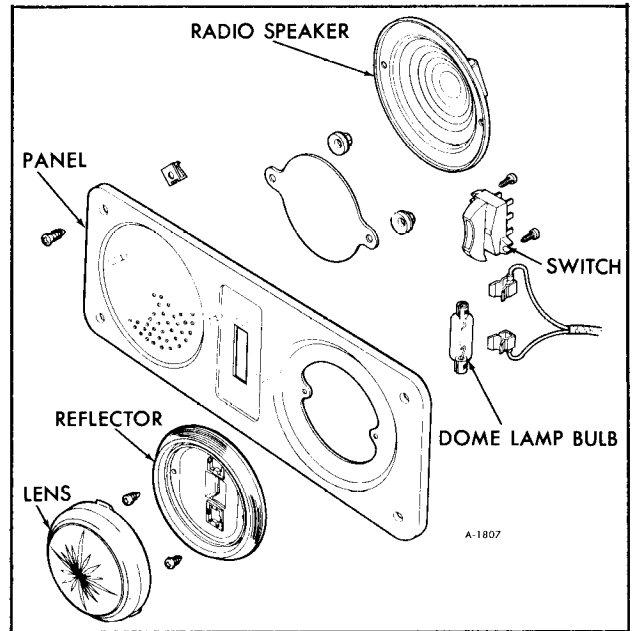

Figure 29—Dome Lamp Installation

FIBER OPTIC RIBBON

Lighting for windshield wiper control, main light switch and washer switch is transmitted through a fiber optic ribbon from a main source bulb located on the L.H. side of the lower instrument panel cover. The ribbon should remain with the instrument panel bezel when the bezel is removed. The source bulb housing can be separated from the wiring harness to free the optic ribbon and permit bezel removal (See figure 30). Bulb number is listed in "Specifications" at the end of this section.

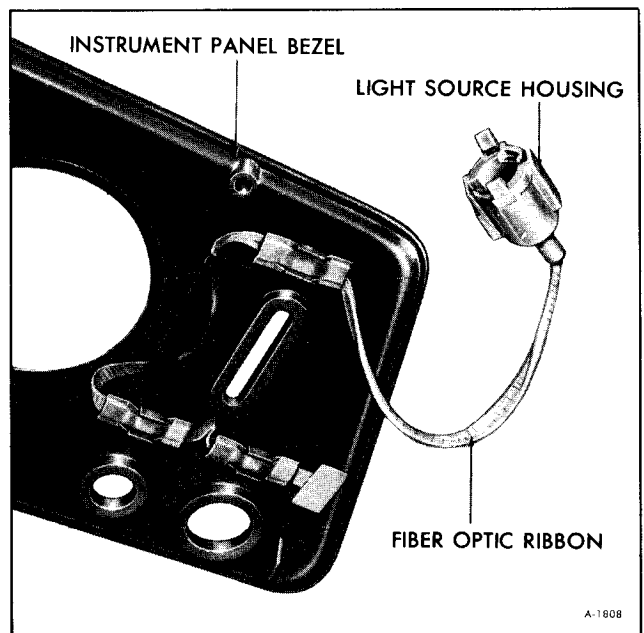
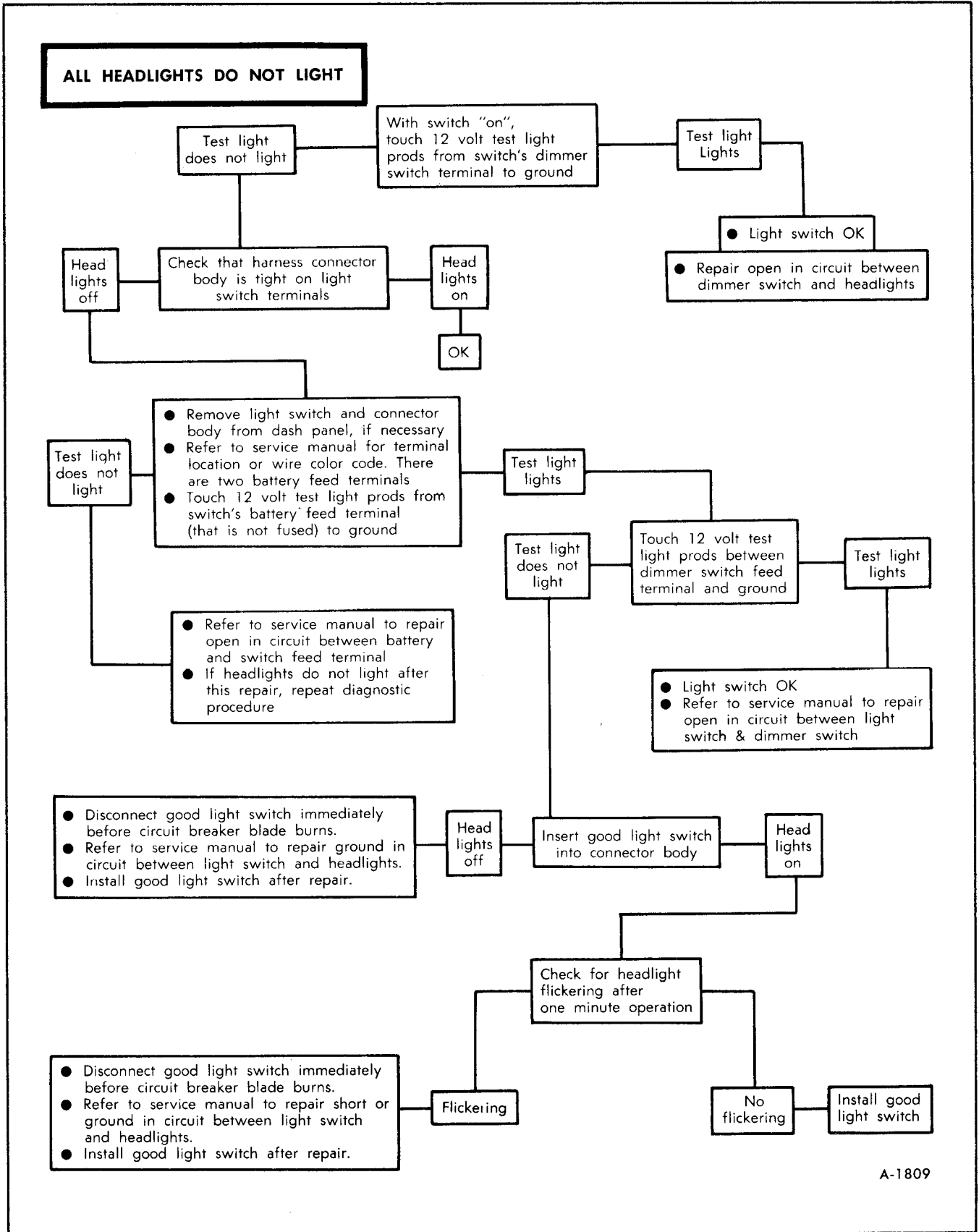

Figure 30—Fiber Optic Ribbon



A-1809

Figure 31-Headlight Switch Diagnosis

ONE HEADLIGHT INOPERATIVE OR INTERMITTENT	
POSSIBLE CAUSE	CORRECTION
Loose Connection	Secure Connections to Sealed Beam Including Ground (Black Wire)
Defective Sealed Beam	Replace
ONE OR MORE HEADLIGHTS ARE DIM	
Open Gr. Connection at Headlight	Repair Black Wire Connection Between Sealed Beam & Body Ground
Black Ground Wire Mislocated in Headlight Connection (Type 2 Sealed Beam)	Relocate as Shown in Service Circuit
ONE OR MORE HEADLIGHTS—SHORT LIFE	
Voltage Regulator Misadjusted	Check and Adjust if Necessary to Specifications.
ALL HEADLIGHTS INOPERATIVE OR INTERMITTENT	
Loose Connection	Check and Secure Connections at Foot Switch and Light Switch
Defective Foot Switch	Check Voltage at Foot Switch With 12-Volt Test Bulb. If Bulb Lights Only at Lt. Blue Wire Terminal, Replace Foot Switch.
Open Wiring - Light Switch to Foot Switch	Check Voltage at Lt. Blue Wire With Test Bulb. If Bulb Lights at Light Switch Lt. Blue Wire Terminal But Not at Foot Switch, Repair Open Wire.
Open Wiring - Light Switch to Battery	Check Voltage at Light Switch Red Wire Terminal With 12-Volt Test Bulb. If Bulb Fails to Light, Repair Open Red Wire Circuit to Battery (Possible Open Fusible Link)
Circuit Shorted to Ground	If, After a Few Minutes Operation, Headlights Flicker On and Off and/or a Thumping Noise Can be Heard From the Light Switch (Circuit Breaker Opening and Closing), Repair Short to Ground in Circuit Between Light Switch and Headlights. After Repairing Short, Check For Headlight Flickering After One Minute Operation. If Flickering Occurs, the Circuit Breaker Has Been Damaged and Light Switch Must be Replaced.
Defective Light Switch	Check Voltage at Light Switch Red and Blue Wire Terminals With Test Bulb. If Bulb Lights at Red Wire Terminal But Not at Lt. Blue, Replace Light Switch.
UPPER OR LOWER BEAM WILL NOT LIGHT OR INTERMITTENT	
Open Connection or Defective Foot Switch	Check Voltage at Foot Switch Headlight Terminals With Test Light. If Bulb Lights at Headlight Terminals (Lt. Green - U.B., Tan - L.B.), Repair Open Wiring Between Foot Switch and Headlights. If Bulb Will Not Light at One of the Foot Switch Headlight Terminals, Replace Foot Switch.
Circuit Shorted to Ground	Follow Diagnosis Shown Above Under "All Headlights Inoperative or Intermittent"

A-1810

Figure 32—Headlight Circuit Diagnosis

HEADLIGHT SWITCH

The headlight switch controls the headlamps, parking lamps, tail lamps, marker and clearance lamps, instrument and dome lamps as well as instrument light intensity. The dome lamps are actuated by turning the headlamp switch fully counterclockwise. The headlamps are protected by a 25 amp. circuit breaker in the headlamp switch which is an automatic reset type. Before replacing the light switch, make sure the trouble is in the switch and not elsewhere in the lighting system by checking circuits as described in Figures 31 and 32.

HEADLIGHT SWITCH REPLACEMENT

1. Disconnect negative battery cables.
2. Pull the switch knob out to the full "ON" position, then reaching up behind the instrument panel, press the spring-loaded release button on the bottom of the switch. Remove the switch rod and knob by pulling straight out with button depressed.
3. Remove the switch retaining nut by inserting a flat-blade screwdriver into the nut while holding the switch from behind the instrument panel.
4. Remove the switch from the instrument panel and disconnect the multiple wire connector from the switch.
5. Reverse steps 1-4 for switch installation.

DIRECTIONAL SIGNALS

For diagnosis of hazard warning and directional signal systems, refer to STEERING (SECTION 9) of this manual.

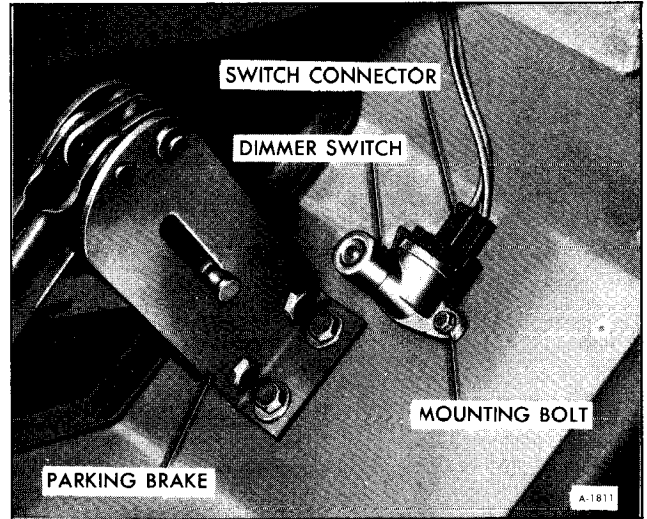

Figure 33-Dimmer Switch

DIMMER SWITCH

The foot-operated dimmer switch (figure 33) is used to select headlight high or low beam. The switch is mounted on the left hand side of the drivers area floorboard and is operative when the headlights are illuminated. See Figure 32 for diagnosis details.

DIMMER SWITCH REPLACEMENT

1. Fold back the carpeting or floor mat in the area of the switch (See figure 33).
2. Disconnect the wiring harness connector from the switch and remove the switch screws.
3. Push the wiring harness connector onto the replacement switch and check operation.
4. Position the switch on the floor panel or toe-board area and attach with (2) screws. Re-position floor mat.

HORN

Two air-tone "S" type vibrating electric horns (figure 34) are mounted behind the left front access door. The electric air-tone "S" type horn is carefully adjusted and inspected during manufacture and should operate indefinitely without attention. The horn assembly should not be adjusted or repaired.

The horn relay-buzzer (figure 35) includes both the horn relay and door buzzer. The horn relay-buzzer operates when the vehicle door is open with the ignition key in the switch and the switch in the "off" position. Closing the door or removing the key will stop buzzer operation. The relay is located behind the right front access door.

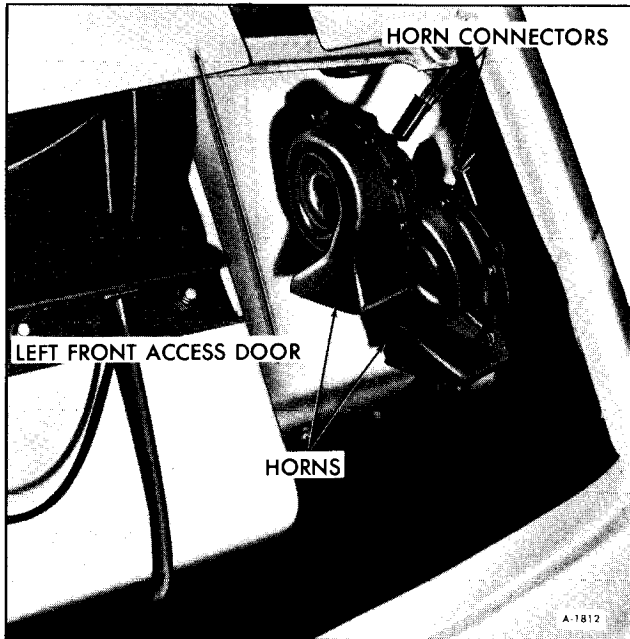

Figure 34-Horn Installation

Refer to ENGINE AND CHASSIS WIRING DIAGRAM for horn and door buzzer wiring circuit.

HORN DIAGNOSIS

For diagnosis of horn system refer to Figure 36.

COMPONENT REPLACEMENT

HORN

1. Disconnect battery ground cables, then open left front engine access door and remove the dark green wires and connectors from the horn assembly.

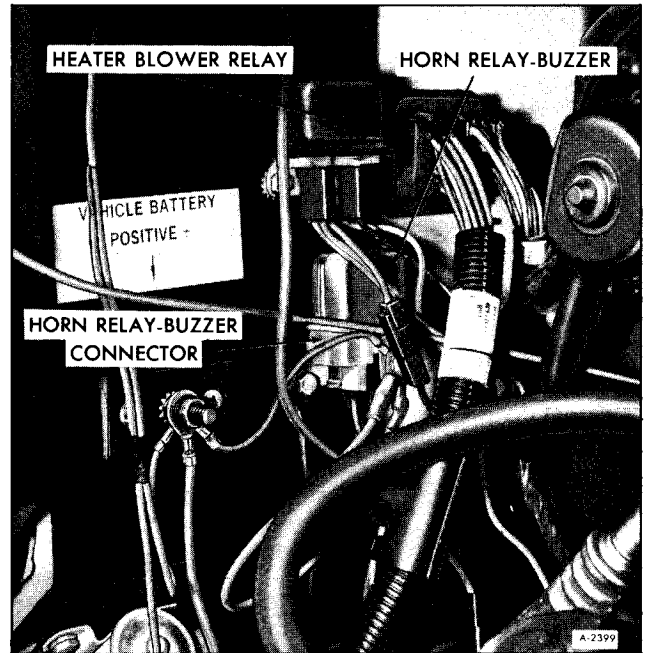

Figure 35-Horn Relay-Buzzer Installation

2. Remove the horn mounting bolts and remove horns (See figure 34).

3. Reverse steps to install horns and check operation.

HORN RELAY-BUZZER

1. Disconnect battery ground cables.

2. Remove horn relay buzzer connector (figure 35).

3. Remove mounting bolt which attaches relay-buzzer to panel.

4. Install buzzer by reversing steps 1-3, making sure that headlamp ground wire is placed under relay mounting tab.

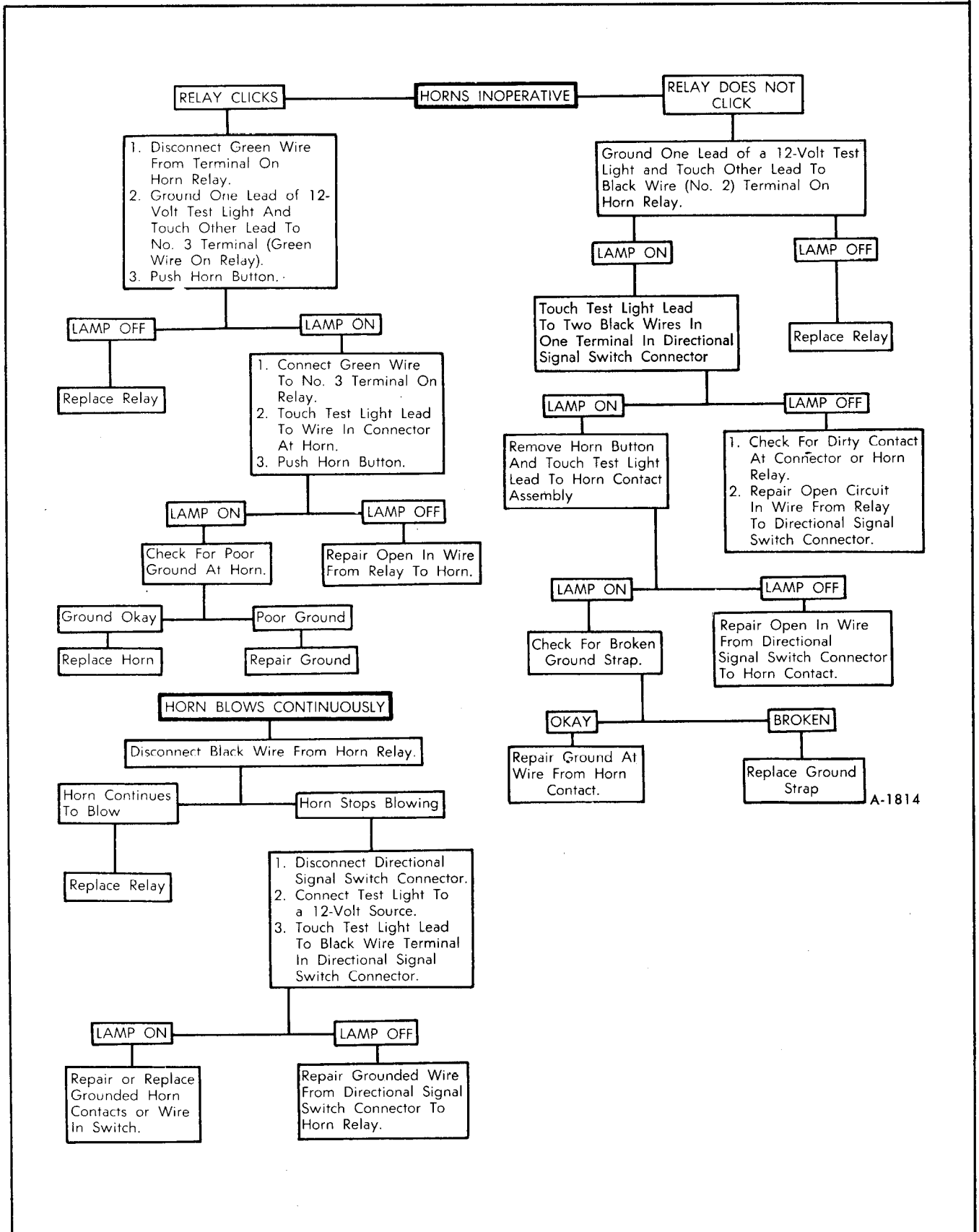

A-1814

Figure 36—Horn Diagnosis Chart

RADIO AND TAPE PLAYER

Radio options include an AM radio, AM-FM, AM-Tape, AM-FM Stereo and AM-FM-Tape Stereo unit. There are two 3-1/2 inch speakers (figure 29) located in each of the front dome light panels and two in each of the rear corners of the vehicle. The antenna is roof mounted with coaxial cable running down the center windshield pillar to the radio.

On AM-FM receivers, a frequency band selector bar is used to change from the AM to FM reception. Moving the band selector bar to the left, engages the FM band and all preset FM stations. Conversely, moving the selector bar to the right engages the AM band. Any preset AM or FM station can be mechanically tuned by depressing the appropriate push button located directly below the band selector bar.

The FM section of the AM-FM and AM-FM Stereo radios is equipped with automatic frequency control, which aids tuning to a station. The FM receiver should be tuned directly on station frequency for minimum noise interference, however, the automatic frequency control will tune directly to and lock on station frequency when slight mistuning is encountered.

Another feature of FM tuning is signal separation. When two FM stations are close in frequency, the FM tuner selects the stronger signal, rejecting the weaker one. This is in contrast to AM performance, where it is not always possible to separate two stations.

The AM-FM radio incorporates an AM receiving circuit and an FM receiving circuit. The audio system is common to both receiving circuits.

On stereo radios, an indicator light on the right side of the dial, will indicate when the FM station tuned is capable of transmitting stereo programs.

With the AM/FM stereo radio and eight-track tape player, the operator may insert a tape cartridge into the opening behind the face of the receiver dial. When the dial face swings up, this automatically removes power from the radio and switches control of the speakers to the tape player. To change tape programs, momentarily depress the volume control knob. To eject the tape cartridge from the engaged position, depress the "EJECT" pushbutton. A cartridge should not be left inserted in the tape player due to possible tape damage.

SPEAKER CONTROL

The right radio knob is used to tune stations

manually. The ring around the knob is the speaker control. When the ring is turned all the way counter-clockwise, 90% of the volume will be shifted to the front speakers. Turning the ring progressively clockwise will shift volume to the rear. When the radio is tuned to an FM-Stereo program, stereo separation will be from side to side.

PUSH BUTTON TUNING

Each one of the five push buttons may be preset to a favorite AM station when on the AM band. Each one of these same five push buttons may be set to a favorite FM or stereo station, giving a total of 10 preset favorite stations. To preset push buttons, proceed as follows:

Select the desired band (AM or FM) and manually tune a favorite station until maximum signal is received. Pull push button out and then push all the way in to relatch. Ten favorite stations (5-AM and 5-FM) can be obtained in this manner.

CAUTION: *Do not move the AM-FM slide bar band selector while any push button is pulled out. Damage to the tuner mechanism may result.*

RADIO NOISE SUPPRESSORS

Various types of ignition suppressors are used to prevent spark noise from interfering with radio reception.

1. Ignition noise is suppressed by use of resistance core ignition cables. The resistance of these cables is 2000 to 6000 ohms-per foot.

2. Make sure resistance spark plugs are being used to minimize ignition noise.

3. It is particularly important that the terminals in the ignition secondary cables make good mechanical contact with the spark plug terminals and distributor cap terminals. A loose connection at these points will result in excessive ignition noise, seriously reducing FM performance.

4. A capacitor mounted on the outside of the ignition coil may be checked by running the engine at medium speed and then quickly turning the ignition switch to the Accessory position. If the noise is

RADIO TROUBLE DIAGNOSIS

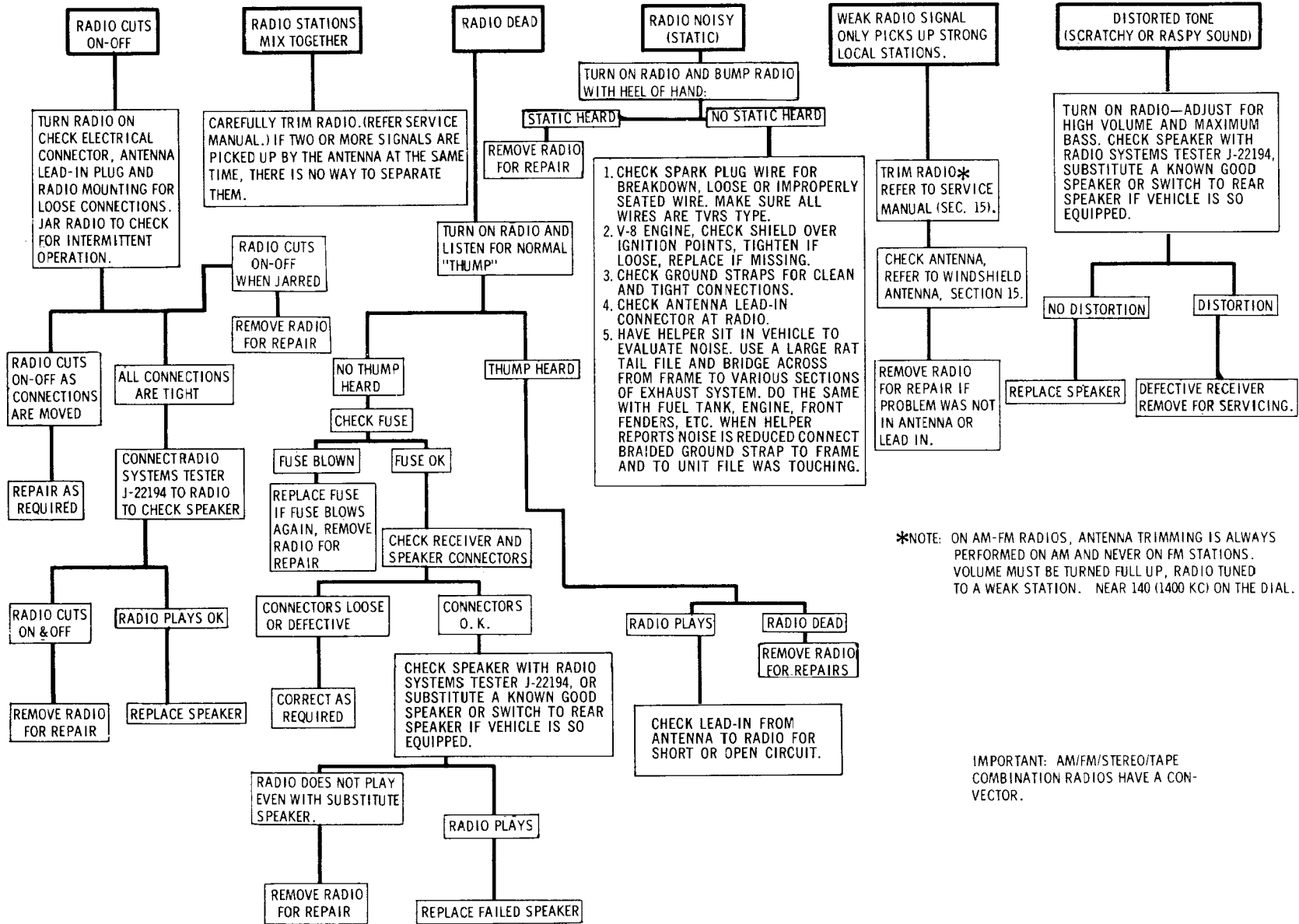

Figure 37—Radio Diagnosis

* RADIO/TAPE PLAYER DIAGNOSIS

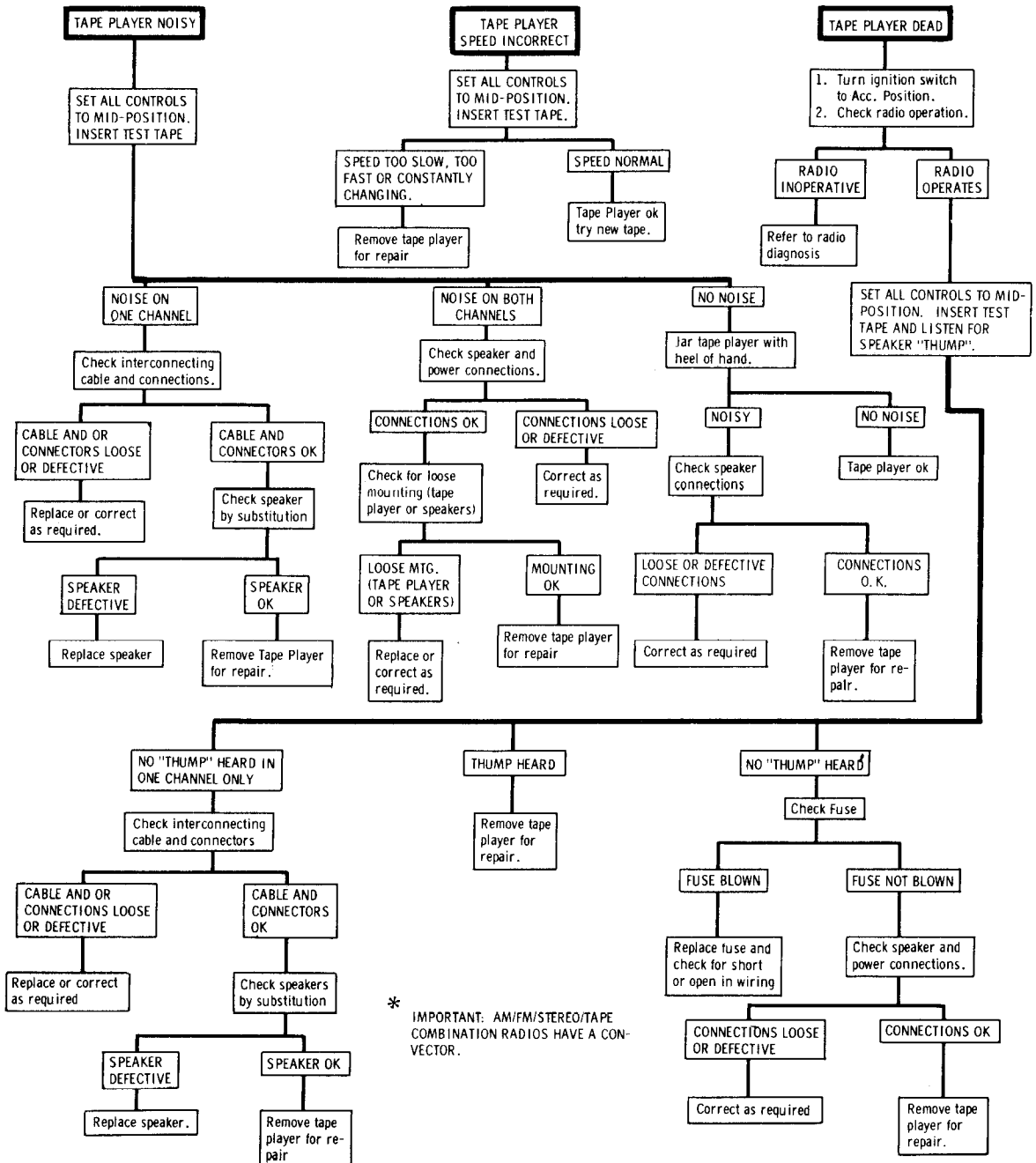

Figure 38—Tape Player Diagnosis

eliminated, while the engine is coasting to a stop, replace faulty coil capacitor.

5. A capacitor is mounted on the blower motor assembly for suppressing radio noise at high blower speeds. If a whine is eliminated when the blower is switched from HI to LO, this capacitor should be replaced.

RADIO AND TAPE DIAGNOSIS

Many conditions that affect radio operation may be corrected without removing set from vehicle. If the checks in Figures 37 and 38 are performed and problem cannot be found, the radio should be removed and repaired at an authorized radio service station.

CAUTION: *Do not turn on radio with any speaker disconnected, as the radio transistor may be permanently damaged.*

SERVICING

ANTENNA TRIMMER ADJUSTMENT

NOTE: If antenna is not trimmed, the set will have weak and fading AM reception. Antenna trimming should always be performed after any radio or antenna repair work.

1. Turn radio on. Switch to AM band if radio is AM-FM.

2. Tune in a weak station at approximately 1400 kilohertz on the AM band and turn volume control to maximum.

3. Adjust antenna trimmer, located behind right control knob ring, for maximum volume. Access to antenna trimmer is gained by removing right control knob and ring and inserting screwdriver to adjust screw (figure 39).

NOTE: If, during adjustment, the station becomes strong so that a change in volume cannot be heard with further screw rotating, tune to a weaker station and continue the adjustment.

ANTENNA MAST REPLACEMENT

If it becomes necessary to remove the antenna mast assembly, refer to Figure 40 for proper part positioning of mast components.

NOTE: Antenna cable passes through center windshield support as shown in Figure 18.

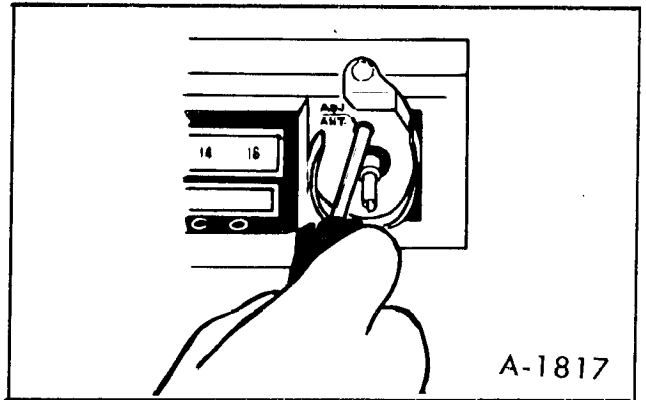

Figure 39—Antenna Trimmer Adjustment

BALANCE ADJUSTMENT (AM-FM STEREO MODELS ONLY)

If the sound appears to be louder on one side of the vehicle than the other, and adjustment to the audio balance may be made.

NOTE: On some stereo programming, it is normal for one side to be louder than the other for a short time. This is done purposely for stereo effect. The only positive method to tell if the balance control needs adjustment is to tune in a non-stereo program and make a critical evaluation.

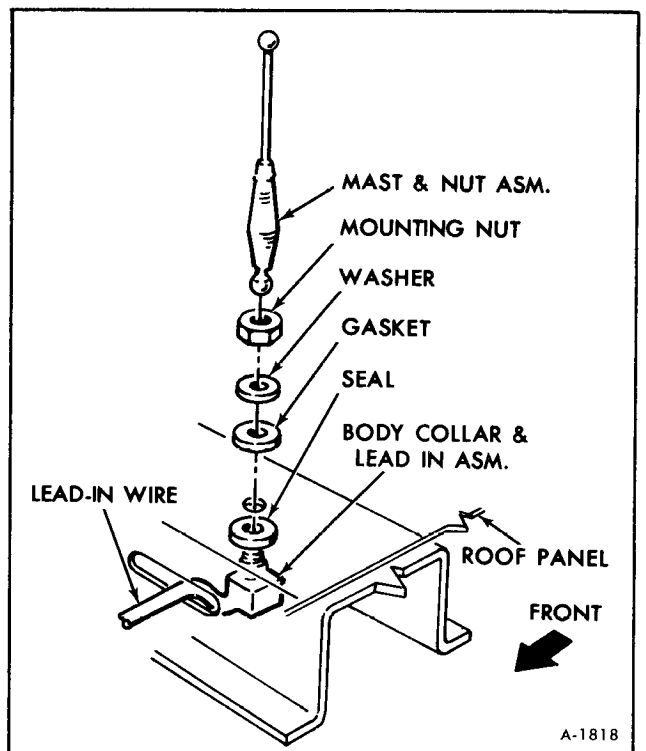

Figure 40—Antenna Mast Installation

If adjustment is needed proceed as follows:

1. Turn radio on. Switch to AM band.
2. Remove left knob, spring and control ring to gain access to stereo balance screw.
3. With fader control turned fully clockwise, insert screwdriver into balance screw.
4. Rotate balance control adjustment clockwise or counterclockwise until the sound in the left and right speakers appears to have equal volume.
5. Install left control ring, spring and knob.

STEREO TAPE PLAYER

The only required maintenance on tape players is periodic cleaning of the tape player head. This service should be performed approximately every 100 hours of operation. If the tape slips and runs slowly, the capstan (revolving metal post), head and tape guide should be cleaned with a cotton swab moistened with alcohol. To clean capstan, trip the on-off switch at the rear of the receptacle and hold the swab against the rotating capstan.

No lubricants should be used since they will cause the player to operate improperly, especially at extreme temperatures.

Do not bring any magnetized tools near the tape head. If the head becomes magnetized, every car-trip played in the player will be degraded.

STEREO TAPE PLAYER CONVECTOR (FIGURE 41)

On units equipped with a stereo tape player, power transistors are located on a remote heat convector due to space limitations. The convector assembly is located behind the glove box door. Connection is made to the convector by means of a 6 wire harness and plug connector running parallel to the fuse block wiring harness from the tape player.

If radio is to be removed for repairs, test the convector, USM radio repair stations do not need the convector to repair the radio if the convector is good.

CONVECTOR TEST (FIGURE 42)

1. Remove the convector harness plug from the rear of the radio.

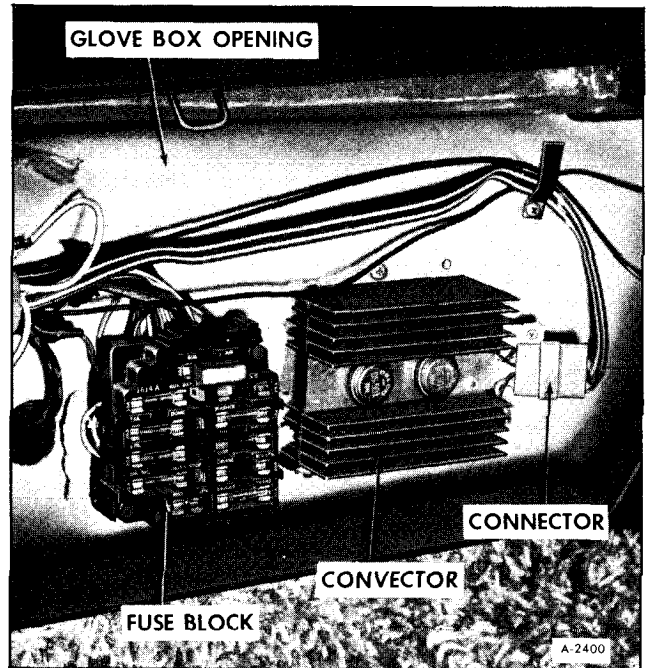

Figure 41—Convector Installation

2. Connect 12 volt test light to 12 volt source.
3. Connect jumper wire to good ground, touch test light probe to jumper to test connections. Test light should light.
4. Touch test light probe to blue wire; jumper to yellow wire.
5. Touch test light probe to blue/white stripe wire; jumper to yellow/white stripe wire.
6. If test light lights in either of the above tests, remove the convector for repair. If the test light is off in both tests, it will not be necessary to send the convector with the radio for repair.

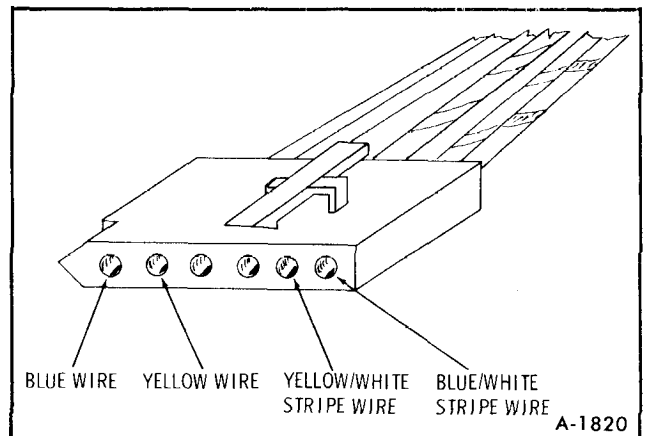

Figure 42—Convector Connector

CONVECTOR REPLACEMENT

1. Convector is located behind glove box on vehicle bulbhead panel.
2. Remove the convector harness connector.
3. Remove the (2) retaining screws and remove convector (See figure 41).
4. To install, reverse steps 1-3.

RADIO DIAL LAMP REPLACEMENT

Radio dial lamp replacement can be made using the following procedures:

All Radio Models

1. Disconnect battery ground cables.
2. Remove the instrument panel bezel and rear cover.
3. Remove the radio knobs and rings.
4. Disconnect the wiring connectors from the rear of the radio and remove radio unit from the instrument panel.

5. Remove the (5) radio case top retaining screws and remove cover.

6. Remove the dial lamp bulb from the holder and replace.

7. To assemble, reverse steps 1-6 above.

Stereo Indicator Lamp Replacement

In cases of a failed stereo indicator lamp on stereo radio models, remove radio and have service performed by an authorized Delco radio repair facility.

MOBILE RADIO TRANSMITTERS

Mobile radio transmitting equipment is subject to Federal Communications Commission regulations and must be installed by a qualified radio technician. The specific installation instructions for radio transmitters will vary depending upon the radio equipment used. Mobile telephone equipment installed by your local telephone company, citizens band radios and electronic garage door openers will not adversely affect vehicle operation. In the event any other type of mobile radio transmitter is to be installed, further instructions are required so that vehicle operation will not be adversely affected. Contact GMC Truck Coach Division, General Motors Corporation, Technical Service Department, Pontiac, Michigan 48053 (or in Canada, contact General Motors of Canada Limited, Product Service Department, Oshawa, Ontario).

CRUISE CONTROL

GENERAL DESCRIPTION

The Cruise Control is a speed control system which employs engine manifold vacuum to power the throttle servo unit. The servo moves the throttle when speed adjustment is necessary by receiving a varying amount of controlled vacuum from the regulator unit. The speedometer cable from the transmission drives the regulator, and a cable from the regulator drives the instrument panel speedometer. The engagement of the regulator unit is controlled by an engagement switch located at the end of the turn signal lever. Two brake release switches are provided: an electric switch disengages the regulator unit and a vacuum switch decreases the vacuum in the servo unit to quickly return the throttle to idle position.

The operation of each unit of the system and the operation of the entire system under various circumstances is described below. Figure 43 shows the location of the system components within the vehicle. See Figure 46 for cruise control system checks.

COMPONENT OPERATION

ENGAGEMENT SWITCH

This switch, located within the turn signal knob, has three positions. In the fully released position, the switch passes current through resistance wire to effect a "hold in" magnetic field in the regulator solenoid. This current is sufficient only to hold the

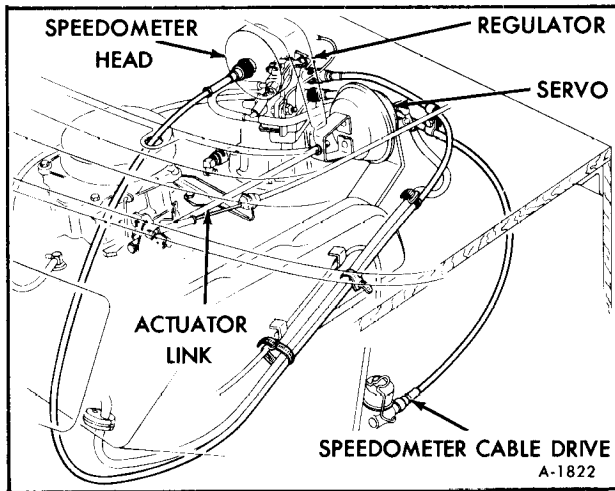

Figure 43—Cruise Control Component Location

solenoid in place once it has been actuated by the “pull in” circuit. Depressing the button partially allows current to flow to the regulator solenoid at full voltage which causes the solenoid to pull in. Depressing the button fully opens the circuit to both the resistance and standard solenoid feed wires and the solenoid becomes de-activated.

During vehicle operation the three switch positions have the following functions:

RELEASED

a. System not engaged: No function of the system will occur although a small current is flowing through the solenoid via the resistance wire.

b. System engaged: The small current flowing through the resistance wire is holding the solenoid in the engaged position.

PARTIALLY DEPRESSED

Full voltage is applied to the solenoid (vehicle speed over 35 mph) which sets the regulator to maintain the vehicle speed at the time of regulator engagement.

FULLY DEPRESSED

No electricity flows to the solenoid and the regulator is inactive. This position is used by the driver when he desires to raise or lower his controlled

speed. He may accelerate to his new speed, press the button fully (regulator releases previously set speed) and release the button. Upon releasing the button, it passes through the partially depressed position and the solenoid is “pulled in”, then into released position which provides “hold in” current. The driver may also press the button fully with no pressure on the accelerator pedal. In this case the regulator releases control of the throttle which returns to idle and the vehicle slows. When the button is released the solenoid is pulled in and held in respectively and the regulator resumes speed control at the speed of the vehicle during the moment of button release (at vehicle speeds over 35 mph).

BRAKE RELEASE SWITCHES

Two brake release switches are employed in the Cruise Control System. When the brake pedal is depressed; an electric release switch cuts off the voltage supplied to the engagement switch, hence cuts off power to the regulator unit. The regulator is then disengaged and requires engagement switch operation to return it to operation. A vacuum release switch operates simultaneously with the electric release switch whenever the brake pedal is depressed. This switch opens a port to atmospheric pressure which rapidly bleeds down the vacuum in the servo unit thereby returning the throttle to the idle position.

SERVO UNIT

The servo unit is a vacuum actuated, variable position diaphragm assembly, which operates the carburetor throttle when the system is in operation. It is powered by controlled vacuum from the regulator and operates the throttle linkage via the adjustable link. (See figure 44) The servo has a port on the sealed side of the diaphragm housing. When controlled vacuum is applied to this port, atmospheric pressure moves the diaphragm which pulls on the adjustable link opening the carburetor throttle.

REGULATOR

The regulator, Figure 45 is a device which has two primary functions. First, it is a vacuum switch which, when engaged by the driver, supplies vacuum to a “Tee” fitting. Second, it meters a small variable quantity of air to the “Tee” fitting where it blends with vacuum, thus providing the power unit with controlled vacuum which will maintain the selected

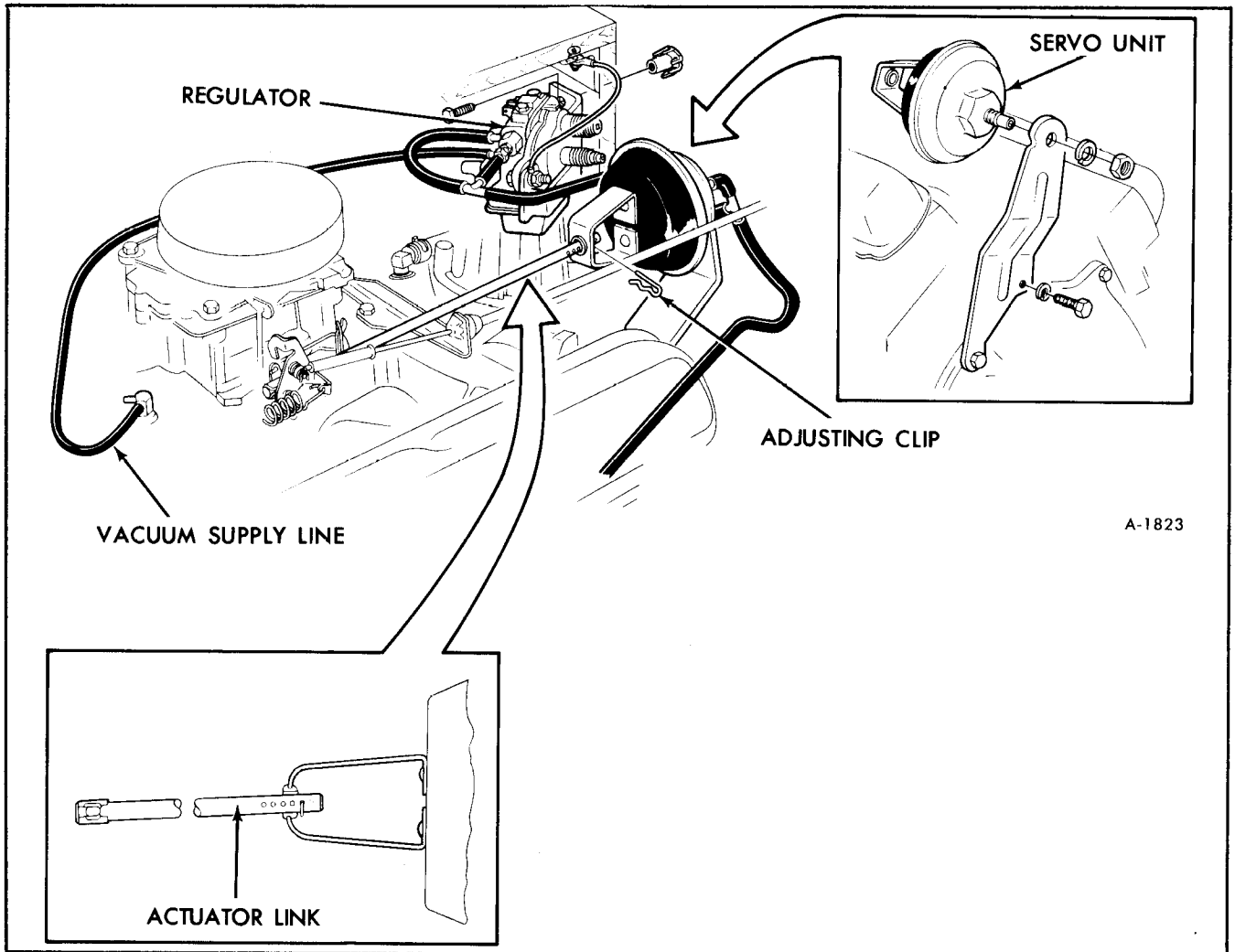

A-1823

Figure 44-Servo Unit Installation

speed. If the regulator begins to supply less bleed air (vehicle speed decreasing) the vacuum in the chamber increases and the diaphragm moves toward the vacuum port. If the regulator begins to supply more bleed air (vehicle speed increasing), the vacuum in the chamber drops and the diaphragm moves away from the vacuum port. In operation, at cruise speed, a proper balance of air and vacuum is blended at the "Tee" fitting and is imposed upon the servo unit to maintain an "on speed" cruise condition.

An additional function of the regulator is to drive the speedometer. Since the vehicle speed is sensed by a speedometer-like mechanism within the unit, the speedometer cable from the transmission drives the regulator which drives a second cable (at a one to one ratio) to the speedometer.

The regulator is electrically engaged and disengaged through operation of the engagement switch and the electric brake release switch. It has two subassemblies which make up the unit: one being the

magnetic speed sensing assembly and the other being the solenoid actuated vacuum switch, air bleed and filter, and low limit speed switch assembly.

Magnetic Speed Sensing Assembly

The speed sensing assembly operates in the same manner as a speedometer unit except that instead of rotating a needle through an angle proportional to the vehicle speed, it rotates a rubber drum which is clutched to the air bleed valve when the system is in operation. The assembly is driven by the speedometer cable from the transmission which turns a disk shaped ferrite magnet.

Facing the magnetic disk is the driven copper disk mounted on a shaft with the rubber drum mounted on the same shaft. A spiral hairspring connects the shaft to the housing and allows it to rotate

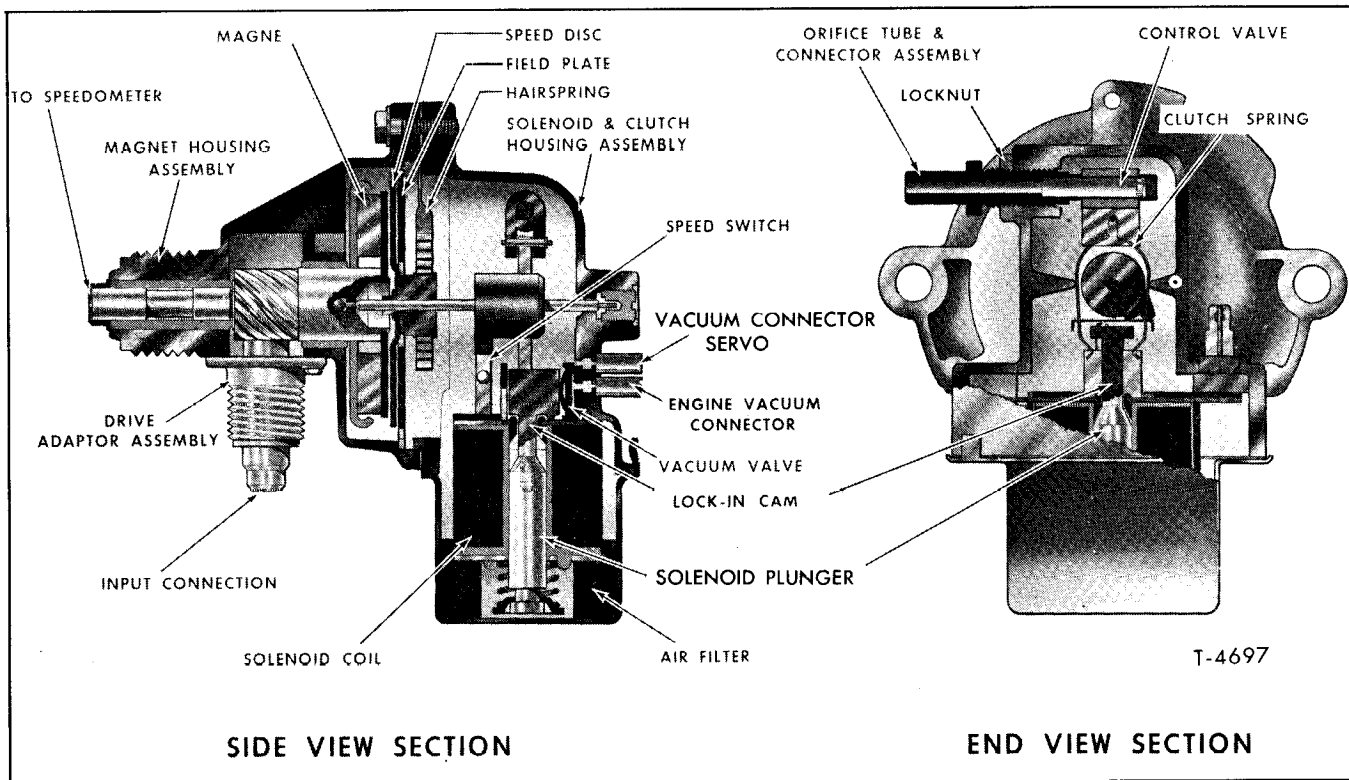

Figure 45-Regulator (Cross-Section)

through an angle which is proportional to vehicle speed. If the vehicle doubled its speed, the shaft would rotate to twice its previous angle as may be seen by noting the operation of a speedometer. The driven disk is sandwiched between the magnetic disk and a field plate. The field plate forms a returning path for the magnetic field from the magnetic disk.

The input shaft drives both the magnetic disk and the speedometer drive cable.

Vacuum Switch, Air Bleed and Filter, and Low Limit Speed Switch

The end of the shaft from the speed sensing assembly with the rubber drum extends into the air bleed metering assembly. This rubber drum has a tang extending from its surface which allows a set of points to close at a specific speed. When the vehicle reaches about 35 mph, the rubber drum has rotated far enough (moved by the brass driven disk in the magnetic field) so that its tang has allowed a spring loaded electrical point to contact another point. These points are in series with the solenoid coil so that under 30 mph, no regulator operation is possible.

Surrounding the rubber drum is a "U" shaped spring clip which is held spread away from the drum by the nose or cam of the solenoid when the solenoid is in the relaxed position. The rubber drum and this clip comprise the speed clutch of the regulator. When the solenoid is energized, the solenoid nose moves toward the drum and releases the ends of the clip. The clip springs inward and attaches itself by friction to the drum. Now, any change in vehicle speed will rotate the drum and move the "U" clip just as a speedometer moves its needle. The top of the "U" clip is attached to the air bleed valve. The clip moves a sleeve which slides on the orifice tube thereby covering and uncovering air ports in the wall of the tube (the tube inner end is plugged) whenever vehicle speed changes from the speed at which the solenoid was energized. The direction of drum rotation is such that resulting bleed valve operation will cause the servo to decrease engine power if the vehicle exceeds the preset speed and increase engine power if vehicle speed decreases. The air which passes out the orifice tube enters the regulator through the openings in the solenoid housing, passes through the oil wetted polyurethane filter, and then enters the orifice tube ports.

When the solenoid is de-energized, the nose retracts and cams the ends of the "U" clip outward so that it releases the rubber drum.

The solenoid also operates a vacuum switch simultaneously with the clutching and declutching of the "U" clip. The solenoid operated vacuum valve slides over two ports in the regulator wall. One port is connected to manifold vacuum and the other is connected to a "Tee" fitting. When the solenoid is de-energized, the valve closes the manifold vacuum port and opens the "Tee" port to the inside of the regulator case. When the solenoid is energized, the valve connects manifold vacuum to the "Tee" fitting, at which point air is blended to the proper proportion and impressed upon the servo unit according to the dictates of the regulator.

During system operation the following events occur:

1. Vehicle speed below 30 mph – no function of the pull-in circuit because the rubber drum has not rotated far enough to close the solenoid points. No pull-in current can flow through the solenoid coil. The solenoid coil is receiving a small current via the 40 ohm resistance wire unless the brake pedal is depressed, engagement switch fully depressed, or the ignition switch is "off".

2. Vehicle speed above 35 mph – the tang on the rubber drum has closed the solenoid points. The pull-in circuit is now ready for engagement.

3. Driver partially presses engagement switch – full voltage flows through the solenoid to pull it into operation. Solenoid cam tension on the "U" clip is released and the clip grips the rubber drum. Simultaneously, the vacuum switch applies manifold vacuum to the "Tee" fitting. Here the vacuum is blended with air being introduced from the regulator. The balance of air and vacuum is impressed upon the servo to provide for initial throttle positioning.

4. Driver releases the engagement switch – current flows to the solenoid through the 40 ohm wire and since the solenoid is "pulled in", the reduced current flow is sufficient to hold it in position.

5. The vehicle begins to ascend a hill – vehicle speed drops slightly (very slightly) and the magnetic force on the driven disk of the speed sensor is decreased. The disk rotates slightly (as would a speedometer shaft because of hairspring tension) turning the rubber drum. Since the "U" clip is gripping the drum, it moves the air bleed valve in that direction which covers the air bleed ports more. With less air bleeding into the "Tee" fitting a higher vacuum level is achieved at the Servo diaphragm, opening the throttle angle to correct for the underspeed condition.

6. The vehicle begins to descend a hill – vehicle speed increases slightly and the air bleed valve moves

in that direction which uncovers the air bleed ports. With more air bleeding into the "Tee" fitting, a lower vacuum level is achieved at the servo diaphragm decreasing the throttle angle to correct for the overspeed condition.

7. Driver accelerates by pressing accelerator pedal – vehicle speed increases and the system responds by moving the diaphragm to decrease throttle opening. Since an adjustable link is used, the link merely slips through the hole in the servo unit and has no effect on throttle operation. After the driver releases pressure from the pedal, the throttle will close until vehicle speed decreases to the pre-set speed. At that point the regulator bleeds less air to the "Tee" fitting which opens the throttle enough to maintain the pre-set speed. The system returns to a stable condition.

8. Driver desires higher controlled speed, presses accelerator until new speed is reached, and depresses engagement switch fully and releases button – speed sensing assembly tries to turn in a direction that would decrease the throttle opening until the driver fully depresses the engagement switch. Then the current is cut off to the solenoid which retracts; the solenoid cam expands the "U" clip releasing its grip on the rubber drum. The drum and disk assembly then rotates to a new position because of the higher vehicle speed. When the solenoid retracts, it also shuts off vacuum to the "Tee" fitting and opens the vacuum port to atmospheric pressure within the regulator thereby bleeding down the servo toward the relaxed position. As the driver releases the engagement switch, "pull-in" and "hold-in" of the solenoid occurs, respectively. The system is now engaged to maintain the vehicle speed at the time of engagement switch release.

9. Driver desires lower cruising speed, presses engagement switch fully, waits until vehicle speed decreases to desired speed then releases switch – when the engagement switch is fully depressed the solenoid is de-energized causing the vacuum switch to bleed down the servo to idle throttle position and the "U" clip of the air bleed valve is released from the rubber drum. The drum and disc assembly is free to rotate to a position which corresponds to vehicle speed as the vehicle slows. When the driver releases the engagement switch, the unit "pulls in" and "holds-in" in the normal manner. The air bleed valve is clutched to the rubber drum at the vehicle speed corresponding to switch release. Vacuum is again applied to the "Tee" fitting and throttle control is assumed by the regulator to maintain the vehicle speed at the time of switch release.

10. With system in operation, driver applies brakes – simultaneously the vacuum release and electric release switches operate. The vacuum switch bleeds air into the servo. The vacuum is reduced in

Problem	Cause	Correction
Will not engage—System Inoperative	Brake Switch Circuit Open Clutch Switch Circuit Open	Check connections— adjust or replace switch. Refer to Electrical Check Out.
	Fuse blown	Replace fuse—if it blows again, check for: 1. Engage Switch stuck in the center of travel— Refer to Electrical Check Out. 2. Incorrect wiring—Refer to Electrical Check Out. 3. Short to ground—Refer to Electrical Check Out. Make necessary corrections.
	Defective Engage Switch	Replace as needed—Refer to Electrical Check Out.
	Vacuum leak in Servo and/or Brake Switch and connecting lines. Vacuum hose not connected to vacuum switch.	Vacuum test and repair or replace as needed. Refer to Servo and Vacuum System Check Out.
	Vacuum release switch misadjusted (always open)	Readjust switch.
	Crossed hoses at regulator	Reroute hoses.
	Open in wiring harness	Repair or replace as needed.
	Pinched or plugged hose that is connected to the Servo.	Free or replace hose.
	Defective Regulator	Replace Regulator
Does not cruise at engagement speed	Orifice Tube misadjusted	Adjust as required.
System hunts, pulses or surges	Actuator Link	Actuator Link
	Kinked or deteriorated hoses (air leak)	Repair or replace.
	Defective and/or improperly positioned Drive Cables and/or Casing Assemblies	Repair or replace as needed.
	Defective Regulator	Replace Regulator.
System does not disengage—with brake pedal	Brake and/or Vacuum Switch mis-adjusted or defective	Adjust or replace as required. Refer to Servo and Vacuum System Check Out and Electrical Check Out.
	wires [which should be connected to the pedal switch(es)] connected to the fuse block	Reroute wires to stoplight switch.
System steadily accelerates or applies full throttle when engaged	Manifold vacuum connected directly to Servo.	Reroute hose.
	Defective Regulator	Replace Regulator.
Cannot adjust speed downward with Engage Button	Defective Engagement Switch or Wiring	Replace as needed. Refer to Electrical Check Out.
Does not engage or engages lower than limits referred to in "Driver Operation"	Defective Regulator	Replace Regulator.
Slow throttle return to idle after brake is depressed.	Pinched air hose at vacuum release switch	Free or replace hose.
System operates correctly, but constant vacuum bleed when system is disengaged.	Crossed vacuum hoses at regulator	Reroute hoses.
High engine idle speed—independent of carburetor adjustments. Constant air bleed through system.	Tight Servo Link	Loosen adjustment.
Constant drain on battery.	Power lead connected to "Fused Battery" terminal of fuse block	Reroute to "Fused Ign." terminal.
System can be engaged at idle by depressing switch, but will drop out when switch is released. Solenoid can be heard when switch is depressed when the vehicle is standing still.	Wires reversed at regulator	Reverse wires.

Figure 46—Cruise Control System Diagnosis

the servo and the throttle returns to idle position. The electric release switch cuts off power to the entire system and the solenoid is de-energized. If the driver removes his foot from the brake pedal the electric switch again feeds voltage to the engagement switch and the vacuum switch seals the air bleed line. The unit will not re-engage since it receives only a small current through the 40 ohm resistance wire. If vehicle speed is below 30 MPH the system may not be re-engaged since the tang on the rubber drum has opened the low limit switch points in the regulator.

DIAGNOSIS

For details on cruise control diagnosis refer to Figure 46.

SERVICING

The components of the Cruise Control system are designed to be replaced should they become inoperative.

The regulator is calibrated in such a manner during manufacturing that overhaul operations are impractical. However, one adjustment may be made to the regulator to correct speed drop or increase at the time of engagement.

BRAKE RELEASE SWITCHES

ELECTRIC

Service—An inoperative switch must be replaced. Switch replacement is identical to standard brake lamp switch replacement.

Adjustment—The brake switch plunger must clear the pedal arm when the arm is moved 1/4 inch measured at the switch. (figure 47)

VACUUM

Service—An inoperative (sticking, plugged, or leaking) switch must be replaced. Switch replacement is similar to brake switch replacement. Be certain that the hose to the switch is connected firmly and is not cracked or deteriorated.

Adjustment—The brake switch plunger must clear the pedal arm when the arm is moved 5/16 inch measured at the switch. (figure 47)

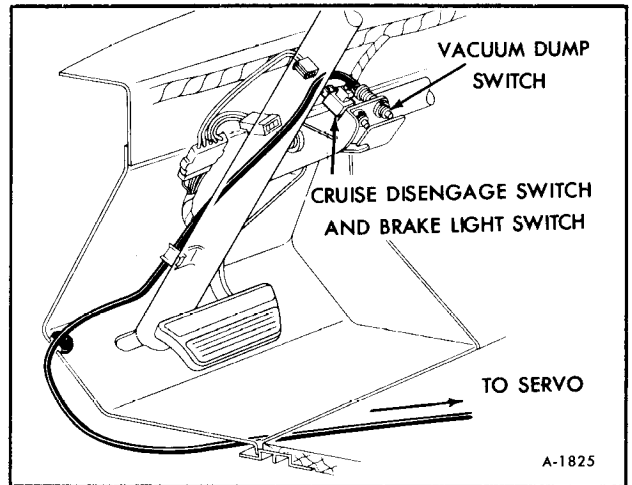

Figure 47—Brake Release Switches

ENGAGEMENT SWITCH

NOTE: The engagement is serviced only by replacement.

REMOVAL

1. Disconnect battery ground cables.
2. Pry the engagement button out of the turn signal knob with a small thin bladed screwdriver.
3. With a small hook or long nosed pliers, remove the switch retaining ring.
4. Remove steering wheel to gain access to turn signal lever attaching screw. Remove screw. Remove turn signal lever from turn signal housing utilizing the slack in the wiring harness.
5. Push slack into turn signal lever slot at base of lever (attachment end). This will force switch out of the other end of the lever.
6. With a small soldering iron, unsolder the wires and resolder them to the correct terminal of the replacement switch. Use only rosin core solder.

INSTALLATION

1. Once a new switch is installed, pull it back into the lever by pulling on the harness at the lever slot.
2. Reinstall retaining ring and button.

3. Push wire slack into turn signal housing; reinstall turn signal lever and steering wheel.
4. Connect battery ground cables.

SERVO

NOTE: If the servo unit is found to be defective, replacement is required. Note the condition of the hoses and replace any which are cracked or deteriorated.

Adjustment—Adjust the actuator link so that it is as tight as possible without holding the throttle open when the carburetor is set at its lowest idle throttle position. When connecting, (engine stopped) manually, set the fast idle cam at its lowest step and connect the link so that it does not hold the idle screw off the cam. (See figure 44)

REGULATOR

A defective regulator, that is one which is not simply out of adjustment, must be replaced. During replacement, check the hoses which connect to the regulator and replace any which are cracked or deteriorated.

ADJUSTMENT

One regulator adjustment is possible: Engagement-cruising speed zeroing (to remove any difference between engagement and cruising speed).

NOTE: No regulator adjustment should be made, however, until the following items have been checked or serviced.

1. Actuator link properly adjusted.
2. All hoses in good condition, properly attached, not leaking, not pinched or kinked.
3. Electric and vacuum release switches properly adjusted.

ENGAGEMENT-CRUISE SPEED ZEROING

If the cruising speed is lower than the engagement speed, loosen the orifice tube locknut and turn the tube outward; if higher, turn the tube inward.

Each 1/4 turn will alter the engagement-cruising speed difference one mph. Tighten the locknut after adjustment and check the system operation at 60 MPH.

ELECTRICAL SYSTEM CHECK OUT

(Refer to Figure 48)

1. Check fuse and connector.
2. Check electric brake switch as follows: Unplug connector at switch. Connect ohmmeter at points A and B on brake switch. The ohmmeter must indicate infinity when the pedal is depressed and continuity when pedal is released. The cruise release brake switch (electric) is adjusted as is the standard stop light brake switch. Replace electric brake switch if needed.
3. Check engagement switch and connecting wiring as follows: Unplug engagement switch connector (brown, black) at electrical wiring harness connector and perform the following tests.

Test #1 – Connect ohmmeter between terminal #1 (brown wire) and terminal #2 white (white wire). Continuity shall be maintained until switch is depressed all the way in.

Test #2 – Connect ohmmeter between terminal #1 (brown wire) and terminal #3 (black). No continuity shall be shown; however, when the button is depressed halfway, continuity shall be indicated. When the button is pressed all the way down, no continuity shall be shown.

Test #3 – Connect ohmmeter between terminal #2 (white wire) and terminal #3 (black). Button released, no continuity; however, when the button is depressed partially and fully, continuity shall be shown.

4. Disconnect engage switch wire harness connector from the main harness connector (brown, brown/white, black wires). Connect ohmmeter between point C (brown/white stripe wire in main wire harness) and ground. Make sure the regulator is well grounded to the chassis. The ohmmeter should read between 42 and 49 ohms. If a resistance either above or below the value indicated is shown, then disconnect the connector from the regulator and measure the resistance of the brown/white stripe wire from point C to D. It should measure 40 ohms \pm 2 ohms. If a resistance either above or below the value indicated is shown, the main wiring harness should be replaced. Note: When disconnecting or reconnecting

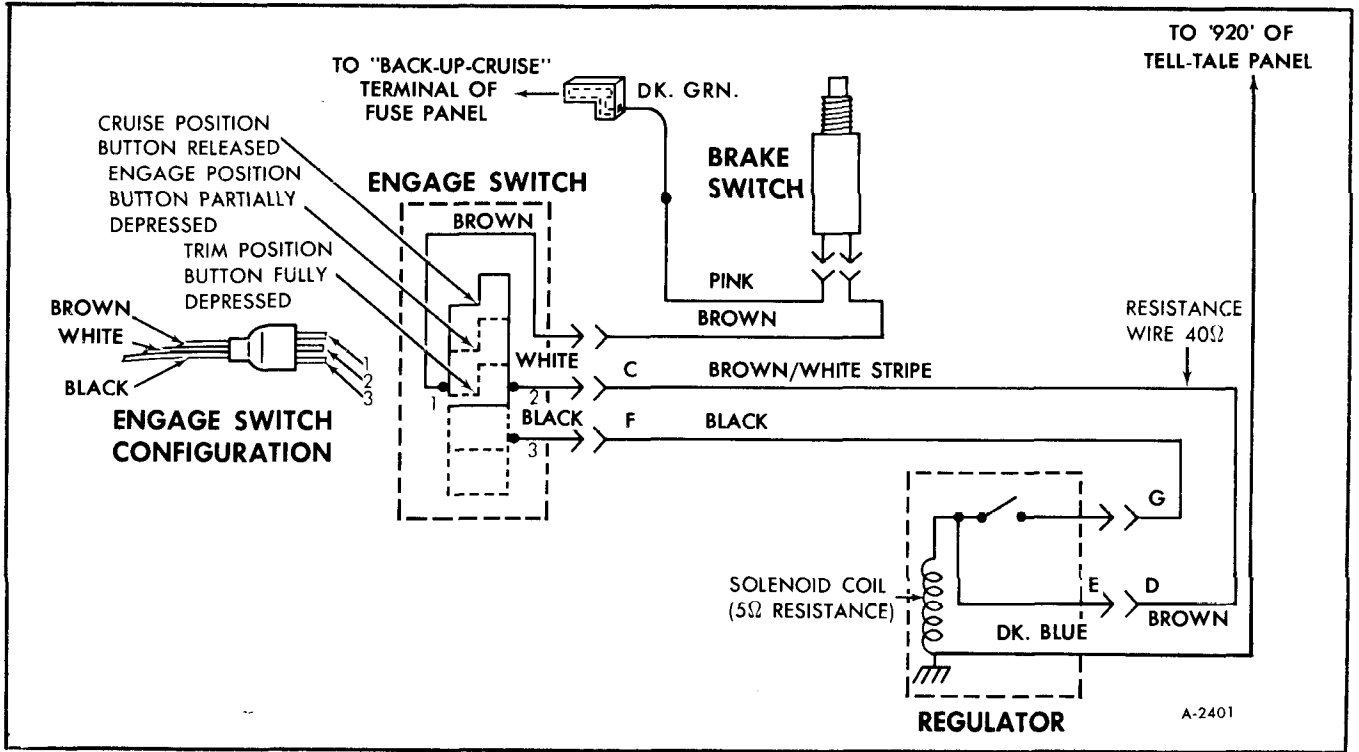

Figure 48-Cruise Control Electrical Diagram

the main wiring harness connector from the regulator, care should be exercised so as not to damage the blade connectors or the wiring harness. The disconnect may be facilitated by prying carefully on the plastic connector with a small blade screw driver.

When measuring the solenoid coil circuit resistance between Point E (Hold Terminal) to ground the

ideal ohmic resistance should be between 5 and 6 ohms. A reading of less than 4 ohms indicates shorting in the coil circuit. A reading of more than 7 ohms indicates excessive resistance in the coil circuit. Either extremity indicates replacement of the regulator assembly. The white main harness wiring from Point F to G should also be checked for continuity.

ENGAGEMENT SWITCH TEST

BUTTON POSITION	TERMINALS		
	1 TO 2	1 TO 3	2 TO 3
Cruise (released).....	closed	open	open
Engage (partially depressed)	closed	closed	closed
Trim (fully depressed)	open	open	closed

SERVO AND VACUUM CHECK OUT

To determine the condition of the diaphragm, remove hose from servo unit and apply 14 inches of vacuum to the tube opening and hold in for one minute. The vacuum shall not leak down more than 5 inches of vacuum in one minute. If leakage is detected, replace servo. To utilize engine as as vacuum source, proceed as follows:

1. DISCONNECT SERVO adjustable link and

hose from servo then connect engine vacuum directly to the servo fitting.

2. Note position of servo diaphragm.
3. Start engine – the diaphragm should pull in.
4. Clamp off engine vacuum supply line and check for leakage.

The cruise release brake switch (vacuum) and connecting hoses can likewise be checked using a vacuum pump.

LIGHT BULB SPECIFICATIONS

Bulb Application	Quantity	Bulb No.	Part No.
Low Air Tell-Tale	1	74	
Brake System Tell-Tale.....	1	161	
Generator Tell-Tale	1	161	
Park Brake Tell-Tale	1	74	
Cruise Control Tell-Tale	1	74	
Door Ajar Tell-Tale	1	74	
Low Fuel Tell-Tale	1	74	
Power Level Tell-Tale	2	74	
High Beam Indicator.....	1	161	
Turn Signal Indicator	2	168	
Instrument Cluster Light	2	194	
Speedo Cluster Light	2	194	
Dome Lights	2	211	9422525
Radio Dial (AM/FM Stereo/Tape).....	1	566	
Radio Dial (exc. AM/FM Stereo/Tape).....	1	1893	
Heater Control	1	1895	
Clearance and I.D.....	10	67	142450
License	1	67	
Side Markers.....	4	194	9421330
Back Up Lights.....	2	1156	
Parking and Turn Sig.	2	1157	9428902
Stop and Tail	2	1157	
Headlights	2	6014	5962548
Fiber Optic Bulb.....	1		9433143



SECTION 13

RADIATOR AND COOLANT RECOVERY SYSTEM

Contents of this section are listed below:

SUBJECT	PAGE NO.
Description	13-1
Maintenance	13-1
Radiator Mountings	13-2
Radiator Replacement	13-2
Pressure Relief Valve and Filler Cap	13-3
Coolant Recovery System	13-3
Engine Coolant	13-3
Cooling System Pressure Relief Valve	13-4
Torque Specifications	13-4

NOTE: Refer to *ENGINE COOLING (SECTION 6K)* of this manual for information relative to coolant circulation, temperature indicators, thermostats, and fan belts.

Refer to **GENERAL INFORMATION AND LUBRICATION (SECTION O)** for information relative to coolant recommendations and coolant system capacities.

DESCRIPTION

All GMC Motor Homes are equipped with a cross-flow radiator also a coolant recovery system. The level in the coolant recovery reservoir should be maintained at the "COLD" line when coolant is cold.

At normal operating temperatures, level can reach "HOT" line on reservoir. However, should the coolant level fall below the cold level line, additional coolant, other than for draining and refill should be added through the coolant recover reservoir.

MAINTENANCE

At regular intervals, cooling system components should be inspected to determine if service is required. Regular systematic checks will reveal faulty condition of various units and indicate necessity of servicing or replacement of such components before failure occurs.

Suggested checks are:

1. Frequently check coolant level. If low, add recommended coolant as required.

2. Check hose connections and tighten clamps if seeping is evident. Cracked, stripped, or corroded clamps should be replaced.

3. Inspect radiator hoses for spongy or checked appearance. Deteriorated hoses should be replaced before bursting occurs which would result in coolant loss and could cause extensive engine damage due to overheating.

4. Check radiator core for leaks and for accumulation of dirt which obstructs air passages and reduces effective heat transfer.

To assist in maintaining efficient heat dissipation, an occasional external flushing with water will remove majority of dirt accumulation and foreign matter from between core fins.

Water under moderate pressure should be directed from behind core to force debris out in opposite direction of its entrance. Water should be directed in line with fins, not sideways, to reduce possibility of bending fins.

5. Inspect radiator mounting pads for deterioration and replace as required.

6. Inspect for proper clearance between fan blades, radiator core venturi ring, and shroud. Check

13-2 RADIATOR AND COOLANT RECOVERY SYSTEM

fan attaching bolts for tightness and observe alignment of fan blades in relation to each other. Replace fan if any blade is bent. Distance between blades and venturi ring should be equal around entire perimeter of the ring. If adjustment is required, venturi ring attaching bolts may be loosened and the ring shifted as necessary to provide proper clearance.

7. Check radiator filler cap seals for evidence of cracking or separation. Replace as required.

8. When coolant loss is evident or engine overheating occurs, the damaged or clogged radiator should be serviced by a radiator specialist or replaced with a new one. Efficient repair of radiators requires the use of special tools and equipment as well as provisions for making proper tests. If radiator core requires painting, spray with special radiator paint; do not use paint mixed with oil, as oil mixed paint will form an insulation and prevent efficient dissipation of heat.

RADIATOR MOUNTING

Refer to Figure 1 for mounting details of radiator support, radiator core, fan shroud and venturi ring.

RADIATOR REPLACEMENT

1. Drain radiator by opening drain cock assembly at lower corner of radiator assembly (location of drain cock shown in figure 1).

2. If unit is equipped with air conditioning, perform the following:

a. Remove front grille.

b. Disconnect air conditioning condenser from radiator.

3. Disconnect radiator overflow tube and upper radiator hose.

4. Raise vehicle.

5. Disconnect lower radiator hose transmission cooler and engine oil cooler lines.

6. Disconnect upper radiator support channel assembly.

7. Remove upper shroud to support bolts (2) and clips attaching seal and venturi ring.

8. Remove retaining strap and move seal away from venturi ring.

9. Remove (2) lower shroud to support bolts & lower shroud.

10. Remove radiator support bolts (3) on each side and lower radiator and support from vehicle.

11. Replace radiator core in radiator support.

12. Install radiator and support in vehicle and torque attaching bolts to 25-30 ft.-lbs.

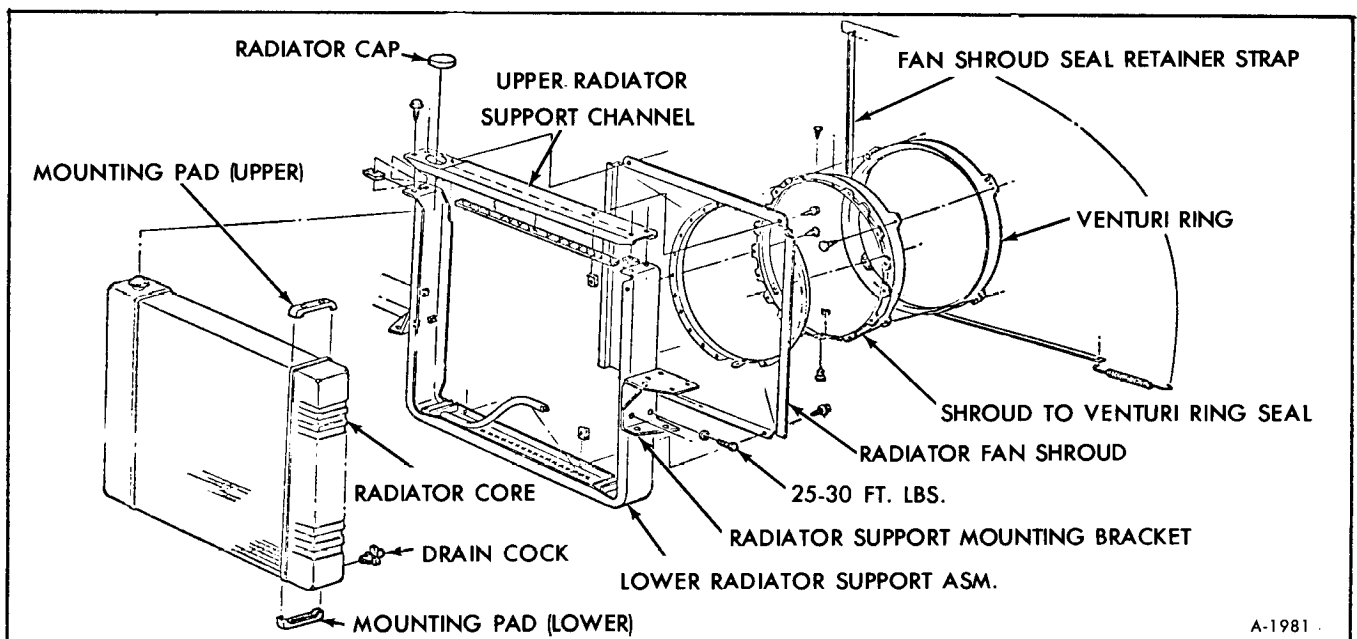

A-1981

Figure 1-Radiator Assembly

13. Install lower shroud to support bolts (2).
14. Install upper support channel assembly bolts (2).
15. Connect lower radiator hose, transmission and engine oil cooler lines.
16. Install shroud to venturi ring seal and tighten fan shroud seal retainer strap.
17. Install clips attaching venturi ring seal to shroud.
18. Install upper shroud to support bolts (2).
19. Lower vehicle.
20. Connect radiator coolant recovery hose and upper radiator.
21. Connect air conditioning condenser attaching bolts (if so equipped).
22. Install front grille.
23. Refill radiator following the procedure described in Section 6K.

PRESSURE CAP AND VALVE

A pressure relief valve assembly, integral with the radiator filler cap, incorporates a pressure valve and a vacuum valve. (See figure 2) When pressure in system reaches valve setting (See "Specification" at end of this section), pressure valve opens and liquid is allowed to escape. As liquid in the system cools it

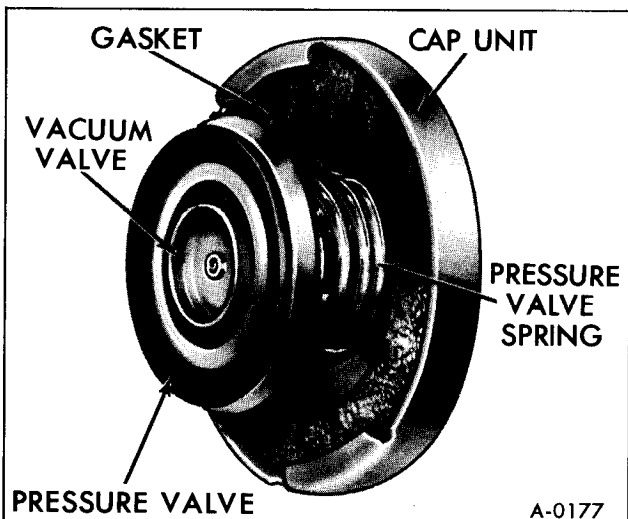

Figure 2—Pressure Cap

contracts; this allows pressure valve to close and also creates a partial vacuum in system. Atmospheric pressure acting through the overflow tube unseats the vacuum valve and allows coolant to enter radiator.

The radiator filler cap is constructed with a spring-loaded rubber seal which is pressed firmly against surface of filler neck seat when cap is installed. Rubber seal must be in good condition and top of radiator filler neck must be clean and smooth in order to form an air-tight seal. Seal of filler cap and operation of pressure relief valve can be checked using a conventional cooling system testing kit.

CAUTION: *When the engine is at normal operating temperature or above, the internal pressure built up in the cooling system will blow out scalding fluid and vapors if the radiator cap is suddenly removed. To prevent loss of coolant and to avoid the danger of being burned, the coolant level should be checked, or coolant added, only to the coolant recovery reservoir. If the radiator cap must be removed when the engine is hot, place a cloth over the cap and rotate the cap slowly counterclockwise to first stop and allow pressure to escape completely. Then turn cap again slowly counterclockwise to remove.*

COOLANT RECOVERY SYSTEM

The coolant recovery system consists of a reservoir, pressure cap and interconnecting hose. The reservoir is mounted above the radiator and is accessible from the front access doors and connected to the radiator filler neck with a hose. The coolant level must be maintained at the "COLD" mark on the side of the reservoir when coolant is cold. A gasket incorporated into the filler cap forms a seal at the radiator filler neck. A leak at this gasket will result in loss of coolant during normal operation. The pressure cap must be installed so that the marking on top of the cap aligns with the overflow tube on the filler neck.

Refer to Figure 3 for removal and installation of coolant recovery system components.

ENGINE COOLANT

COOLANT RECOMMENDATIONS

For coolant drain and refill procedure, refer to SECTION 6K of this manual. Cooling system maintenance intervals will be found in SECTION O.

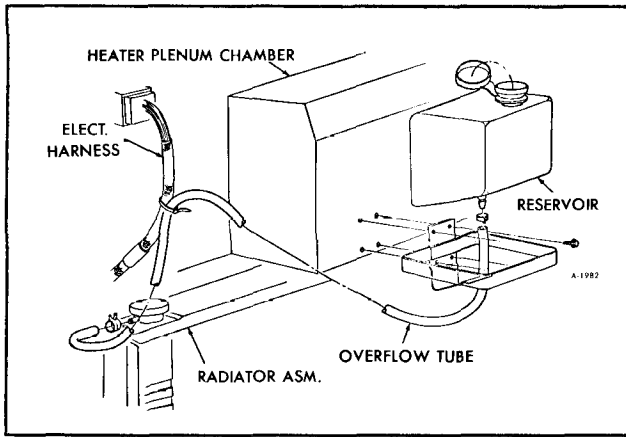

Figure 3-Coolant Recovery System

COOLANT TESTING

Always test solution before adding water or anti-freeze. Engine should be warmed up to operating temperature. Fill and empty tester several times to warm tester before using. Keep tester clean inside and out.

Some testers will indicate correct freezing point only when test is made at a specific temperature. Other testers are provided with thermometers and tables and indicate freezing points corresponding to readings made at various temperatures. Disregarding temperatures of solution may cause an error as large as 30°F. Read and be guided by instructions furnished by the tester manufacturer.

In the event coolant freezes solid in extreme cold weather, place vehicle in warm building or improvise some means of thawing coolant before starting engine. Under no circumstance should engine be operated, when coolant is frozen solid. After thawing, refill system with a higher concentration of anti-freeze solution and start engine. Inspect entire system for leakage and then test coolant with hydrometer to determine if adequate anti-freeze protection is provided.

COOLANT PRECAUTIONS

1. Overheating is not always caused by a defective cooling system; incorrect ignition timing, dragging brakes, under-inflated tires, can cause overheating.
2. Keep water pump and fan drive belts at proper tension. Refer to ENGINE COOLING SYSTEM (Section 6K) of this manual.
3. Do not remove radiator filler cap when engine is hot. Wait until system cools off.
4. Do not pour cold water into cooling system when the engine is hot. Wait until system cools off.
5. If cooling system requires frequent refilling, check for leaks.
6. Keep all connections tight, and make sure gasket on radiator filler cap is in good condition.
7. When filling system with anti-freeze solution. Always follow recommendations of anti-freeze manufacturer.
8. Use only Ethylene Glycol base coolant meeting GM Specification 1899M.
9. Drain and flush cooling system every other year, preferably at start or end of winter operation.

COOLING SYSTEM PRESSURE RELIEF VALVE

Models	Valve Stamped	Opening PSI
230 (23') 260 (26')	RC32	9

TORQUE SPECIFICATIONS

- Radiator Support Mounting Bracket to Radiator Support Attaching Bolts 25-30 ft. lb.
 Drain Cock 8-10 ft. lb.

SECTION 14

BUMPERS

ENERGY ABSORBERS

DESCRIPTION

All GMC Motor Homes have both bumpers mounted to energy absorbers. (figure 1)

The energy absorber is a device which uses hydraulic fluid within the cylinder tube to absorb impact energy and inert gas to restore the bumper to its original position after a low speed collision. Right and left energy absorbers are the same. (figure 1)

During impact (figure 2) the piston tube moves back into the cylinder tube. Hydraulic fluid is forced from the cylinder tube through the orifice around the metering pin into the piston tube. The metering pin controls the rate of fluid flow. Fluid pressure in the piston tube against the floating piston moves it and compresses the gas. After impact (figure 3), gas pressure against the floating piston forces fluid back into the cylinder tube and pushes the bumper back to its original position.

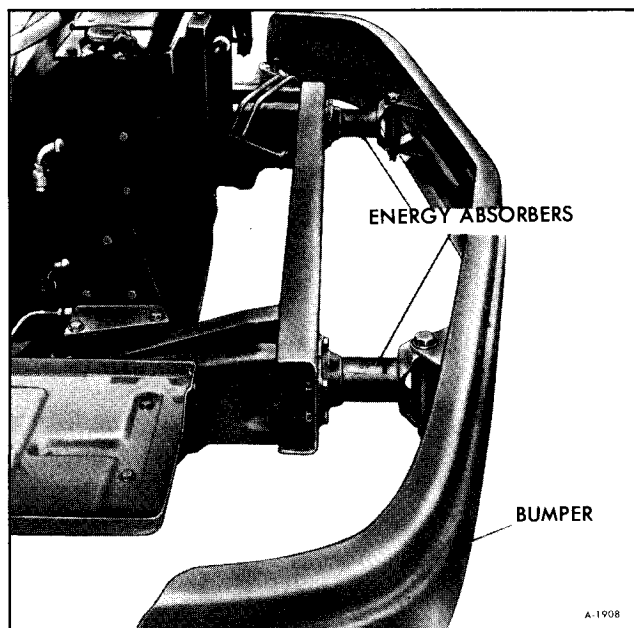

Figure 1—Energy Absorbing Bumper

DIAGNOSIS

LEAKAGE

A trace of oil on the piston tube is normal due to grease packed in the seal area during manufacturing. If oil is dripping from the unit it should be replaced.

DAMAGE

Inspect the bumper bracket, frame bracket, piston tube and cylinder tube for evidence of visible distortion. Scuff marks on the piston tube are normal. If there is obvious damage to the unit it should be replaced.

ON VEHICLE TEST

This test involves compressing EACH unit separately $3/8$ " or more and observing that the bumper returns to its normal position.

1. Turn off ignition, transmission in park, parking and service brakes set.
2. Use a barrier such as a pillar, wall, post, etc.
3. Align a pressure device, such as a hydraulic jack, with the energy absorber. Make sure it is positioned squarely with the bumper so it will not slip.
4. Apply pressure to compress the unit $3/8$ ". Use a 6" scale to determine travel. Release pressure and note if the bumper returns to its normal position.
5. If either unit fails to return to its normal position, replace it.

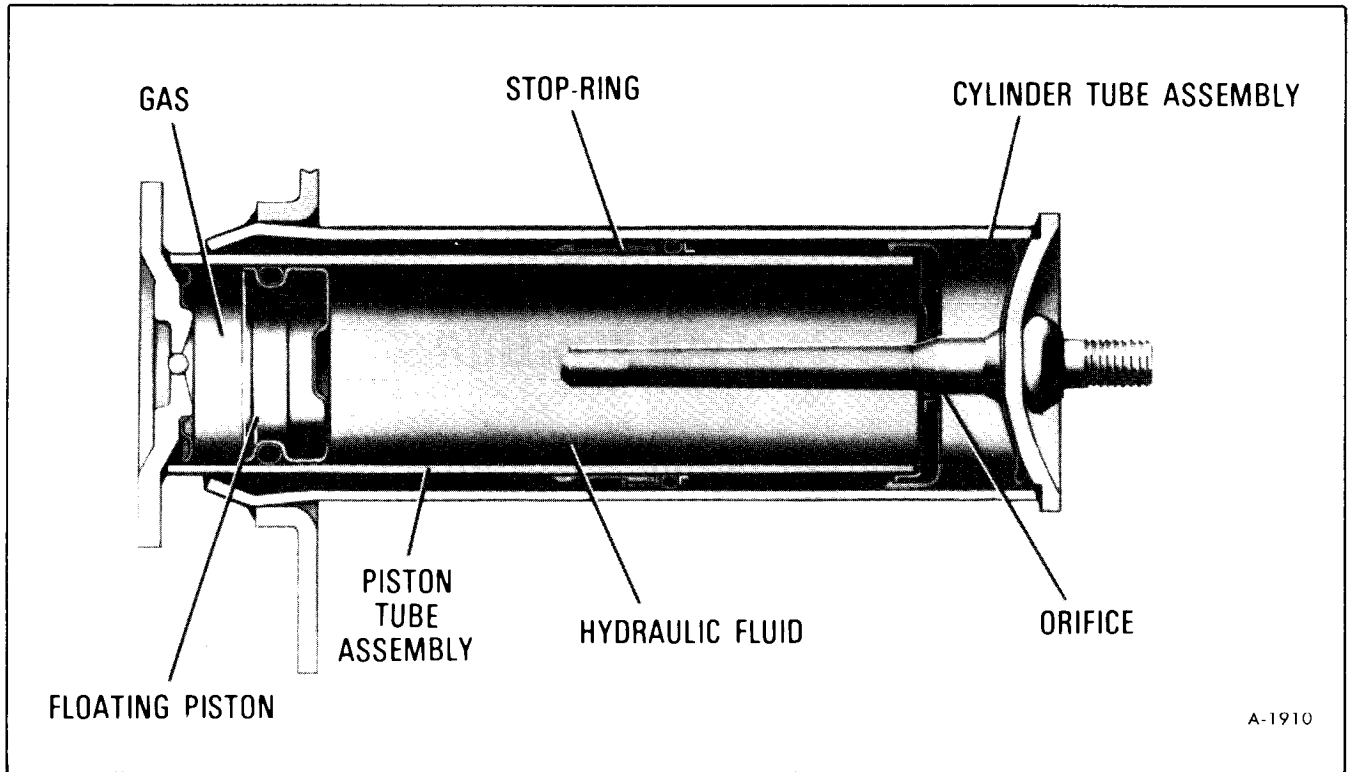

Figure 2—Energy Absorber—Collapsed Position

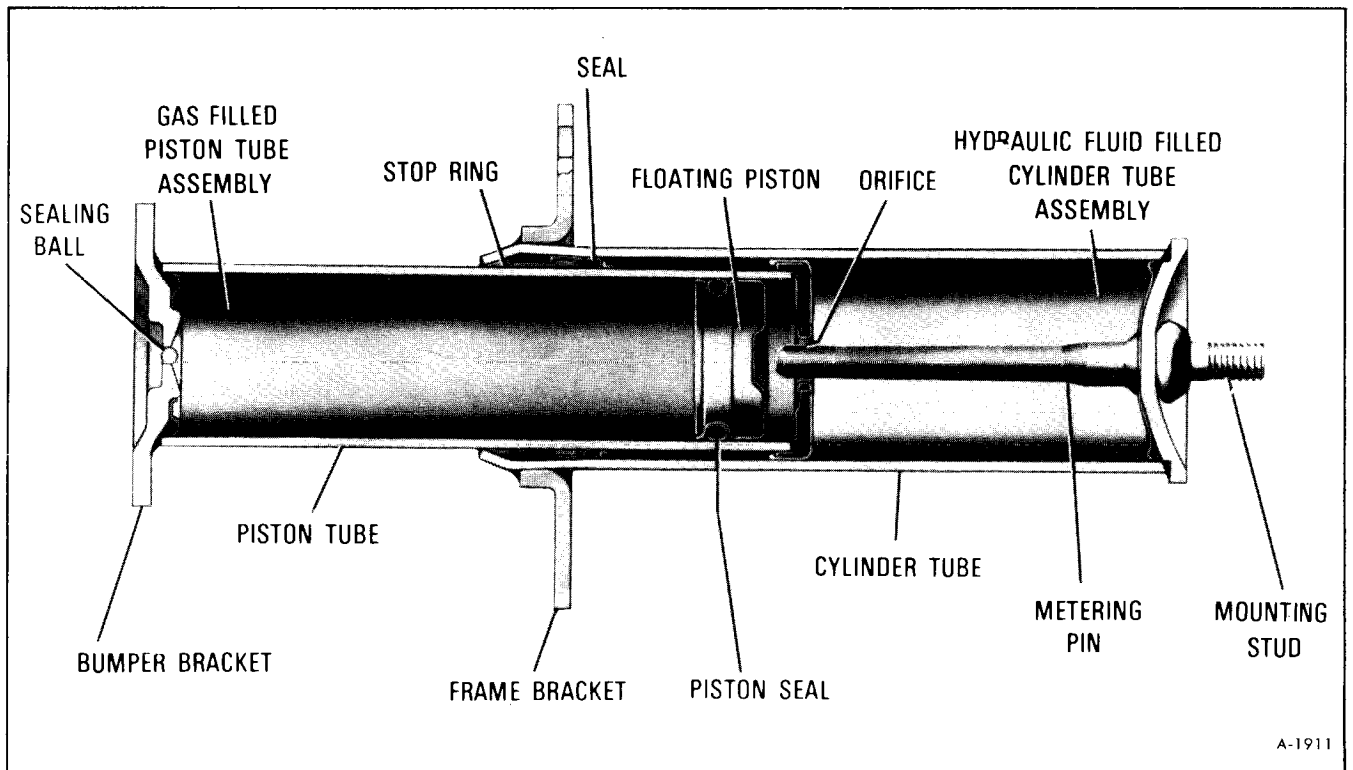

Figure 3—Energy Absorber—Extended Position

BENCH TEST

The bench test may be used to pre-test service units prior to assembly on a vehicle or to check detached units that may have been removed for the purpose of making vehicle repairs after a collision.

A suitable arbor press should be used to compress the unit $3/8"$. Observe if it returns to its normal position. If not, this unit should be replaced.

INSPECTION

Recommendations for handling energy absorbers are:

1. Do not attempt to repair.
2. Do not weld.
3. Do not apply heat.

WARNING: BE SAFE! PROTECT YOUR EYES. WEAR APPROVED SAFETY GLASSES.

4. Relieve gas pressure prior to disposal of a unit. Make an indentation with a center punch in the small cylinder section of the energy absorber (recommend "WARNING" label on the unit as a target area). Then, use a 1/8-inch drill to penetrate the small cylinder and relieve gas pressure (See figure 4).

INSPECTION AFTER COLLISION

If the collision was so severe that the bumper did not return to its original position, the energy absorber(s) will require replacing.

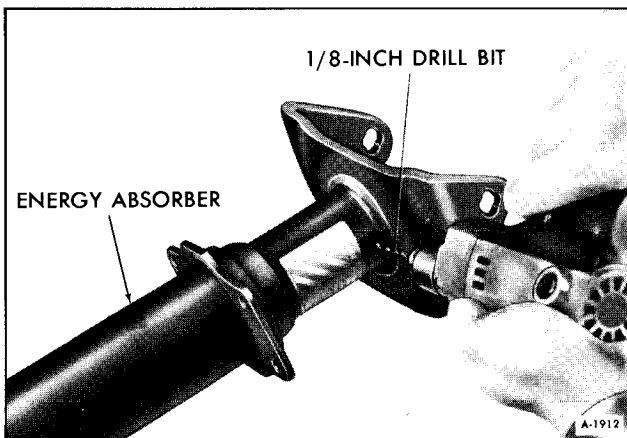

Figure 4—Relieving Pressure from Energy Absorber

WARNING: BE SAFE! PROTECT YOUR EYES. WEAR APPROVED SAFETY GLASSES.

1. Stand clear of the bumper.
2. Provide positive restraint, such as a chain or cable.
3. Relieve the pressure by drilling a 1/8-inch hole in the piston tube near the bumper bracket (See figure 4).
4. Remove the unit from the vehicle as described under "Replacement" only after the gas pressure has been relieved.

REPLACEMENT

NOTE: Front and rear bumpers and energy absorbers are similarly mounted so replacement procedures are the same for front or rear.

IMPORTANT: Prior to replacement, be familiar with procedures given under "INSPECTION" of energy absorbers.

1. Remove bumper by removing both bumper bracket thru bolts as shown in Figure 5.
2. Remove the four bolts and nuts securing energy absorber to frame.
3. Secure new energy absorber to frame with bolts and nuts. Torque to 45 foot pounds.
4. Install bumper on energy absorbers and secure with thru-bolts.

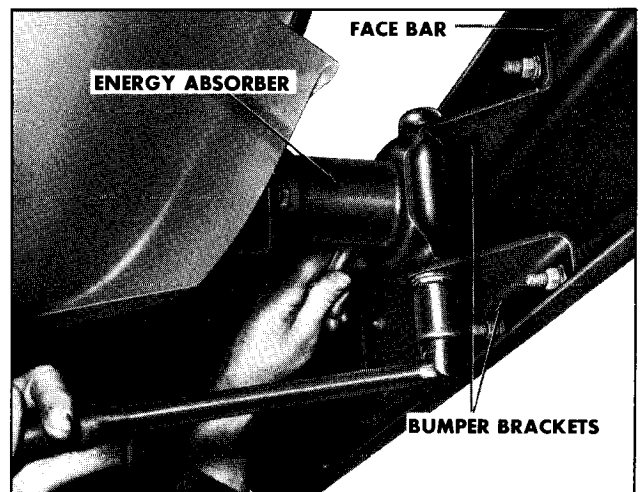

Figure 5—Removing Bumper Bracket Thru-Bolts

BUMPER FACE BARS

NOTE: Front and rear bumper face bars are similarly mounted so replacement procedures are the same for front and rear. Also, due to the fact that both front and rear bumper face bars are two piece assemblies in some cases it may only be necessary to replace half of the face bar.

REPLACEMENT

1. Remove face bars by removing both bumper bracket thru- bolts (See figure 5).

2. Remove brackets and hardware from old face bar(s) and install on new face bar(s).

3. Once it has been determined that the energy absorbers are operative, install the face bar assembly on energy absorbers and secure with thru-bolts.